

# 60" DOUBLE SINK BASE CABINET

## BASE CABINET DIMENSIONS

60" W x 21.5" D x 33.5" H



## FEATURES

- Solid wood frame with engineered wood panels
- Dovetail drawers and joints
- Soft closing doors & drawers

## HARDWARE FINISHES\*



Brushed Nickel    Satin Brass    Matte Black    Polished Chrome

*Hardware comes preinstalled with the illustrated option. Other finishes are available on our online store if you prefer a different one.*

## AVAILABLE COLORS



White    Grey

## FRONT VIEW

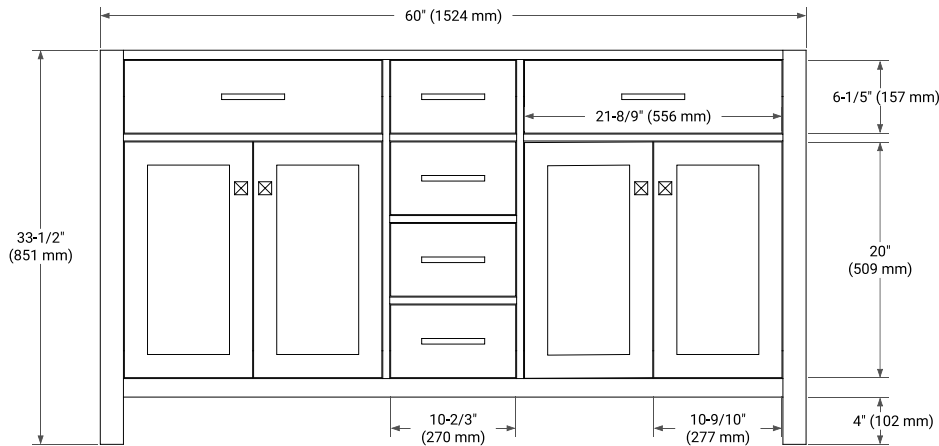

## SIDE VIEW

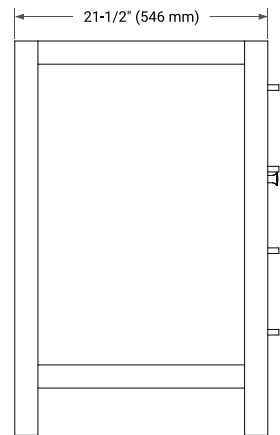

## PLAN VIEW

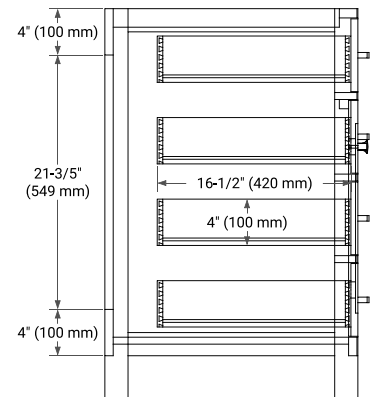
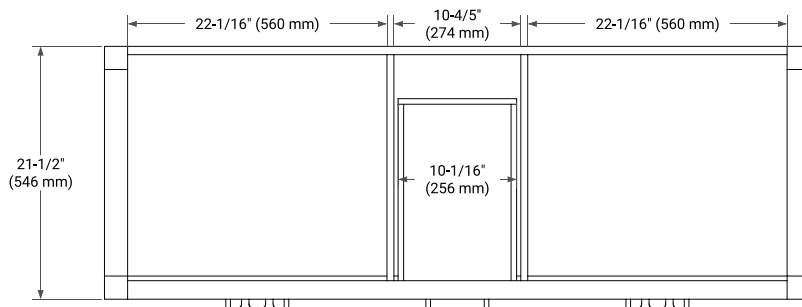

# 61" DOUBLE RECTANGLE SINK COUNTERTOP WITH 1.5" THICKNESS

## OVERALL DIMENSIONS

61" W x 22" D x 1.5" H

## COUNTERTOP OPTIONS



Carrara Marble



White Quartz

## FEATURES

- Solid countertop with mitered edges & seams
- Undermount white rectangular sink
- Pre-drilled for 8" widespread faucet

## INCLUDED

- Countertop
- Matching Backsplash
- Rectangle Sinks

## COUNTERTOP PLAN VIEW

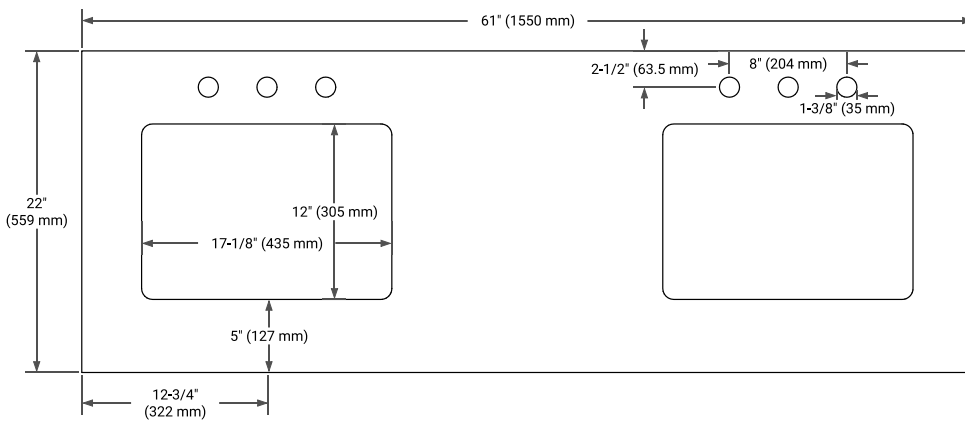

## EDGE SIDE VIEW

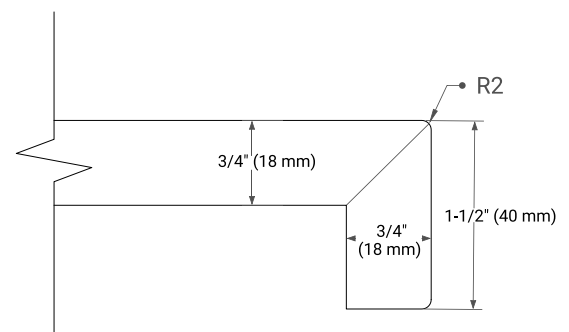

## THREE DIMENSIONAL COUNTERTOP VIEW

