





CARE AND MAINTENANCE

Wipe clean with a soft, dry cloth. Test the cleaning method on a hidden area before using them over the entire area.

NOTICE

- * Please make sure that you have all parts indicated before you begin assembly of this item.
- * This item should be assembled on a soft surface to prevent scratching the finished product during assembly.
- * This item may require periodic tightening.
- * Do not tighten bolts until completely assembled.

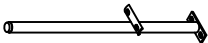
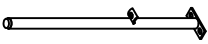
Part List and Hardware List

PIECE	DESCRIPTION	PICTURE	QUANTITY
A	Seat Cushion		1x
B	Middle Frame		1x
C	Leg		4x
D	Leg		2x
H1	Allen Bolt	 1/4"x 5/8"	22x
H2	Allen Key	 M4	1x

Product Dimensions: 63"Wx22"Dx20"H

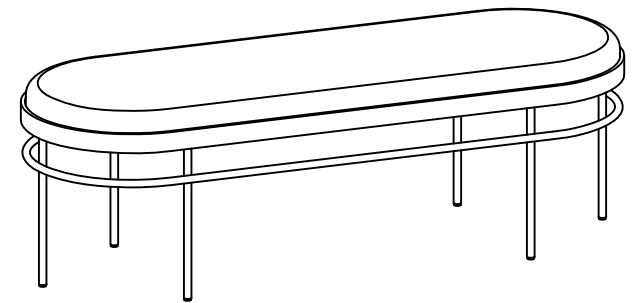

Weight capacity : 550 lbs
WARNING:DO NOT STAND ON THE BENCH

PREPARATION

Before beginning assembly of product, make sure all parts are present. Compare parts with package contents list and hardware contents list. If any part is missing or damaged, do not attempt to assemble the product.

Estimated Assembly Time: 20 minutes.

Tools Required for Assembly (included): Allen Key

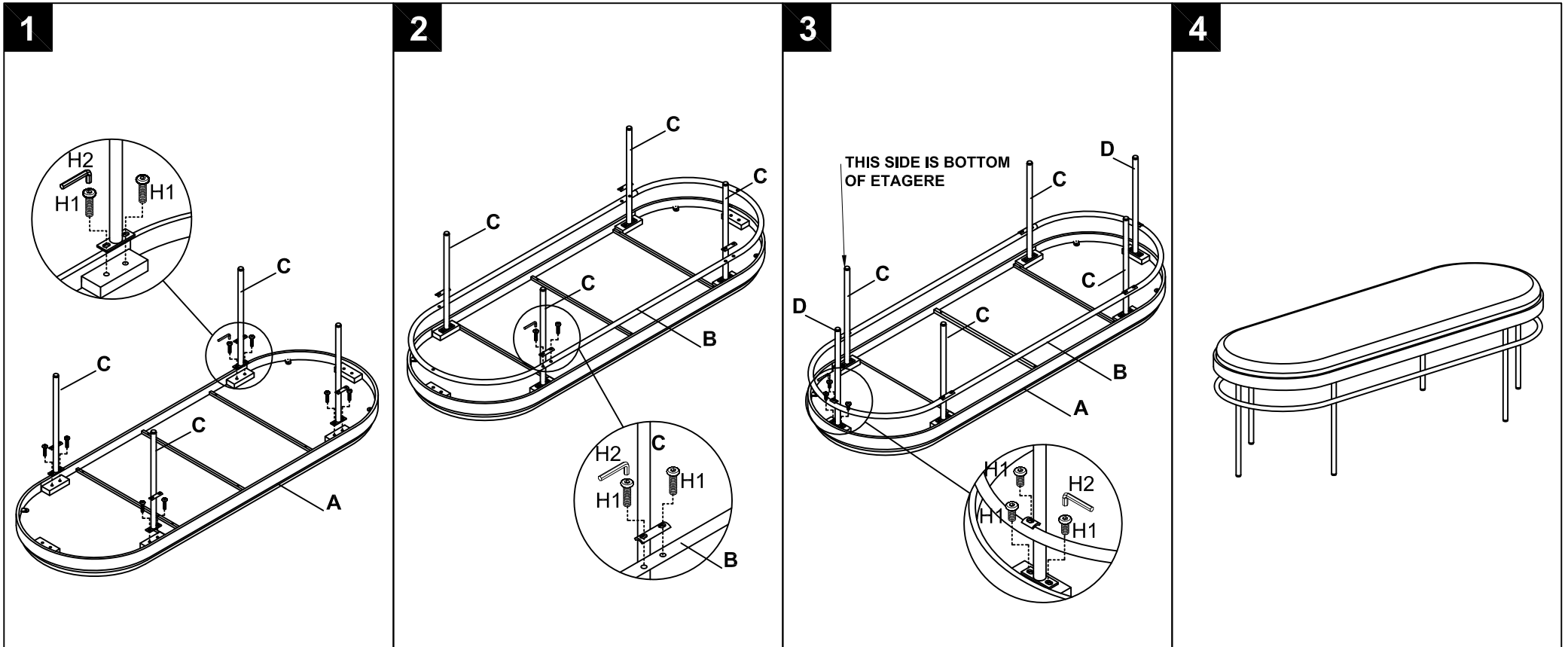

Step 1

Attach 4*Legs (C) to the underneath of seat cushion (A), Use Allen key (H2) to lock by 8*Allen bolts (H1), as picture.

Step 2

Place the middle frame (B) to outside of 4* metal legs (C), aligning all screw holes and by using Allen Key (H2) to lock 8*Allen bolts (H1) to the underneath of middle frame (B), as picture.

Step 3

Attach 2*Legs (D) on both ends to the middle frame (B), aligning all screw holes and using Allen Key (H2) to lock 6*Allen bolts (H1) to the underneath of middle frame (B), as picture.

Step 4

Assembly is completed.