

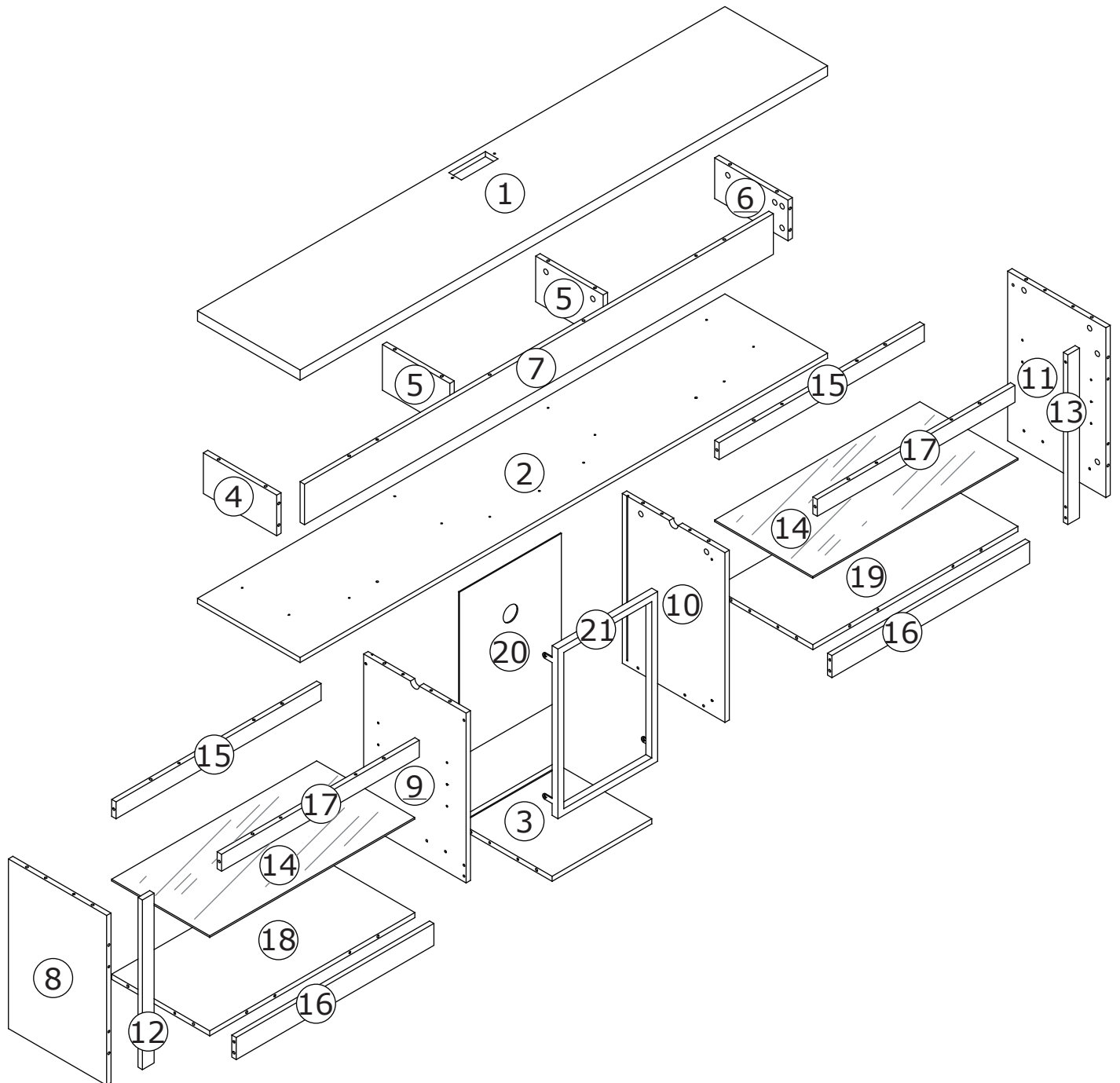

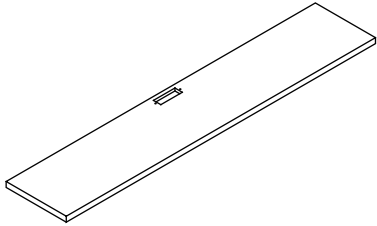

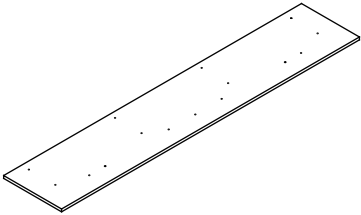

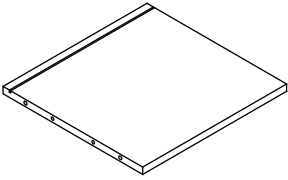

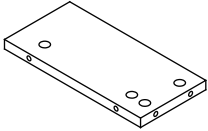
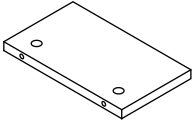
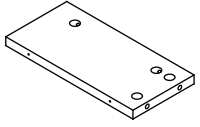
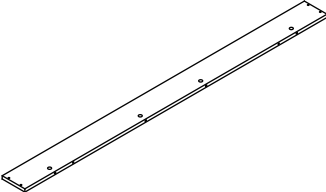
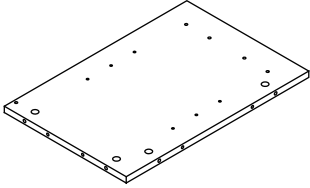
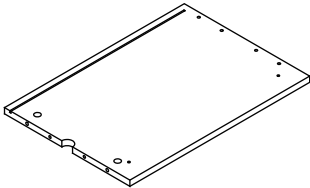
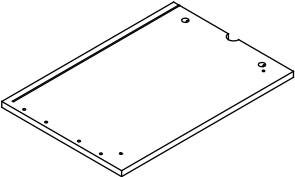
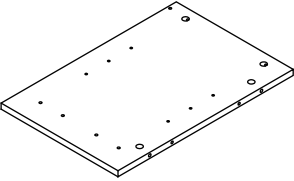
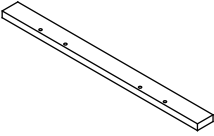
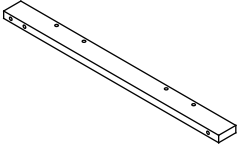
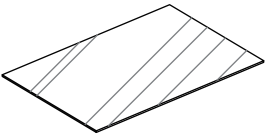
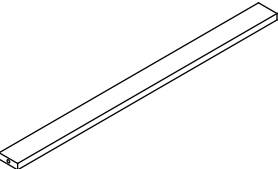
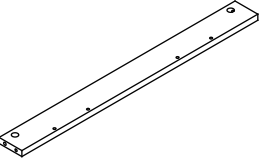
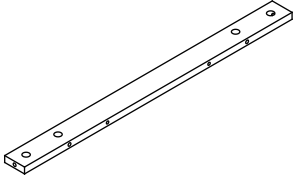
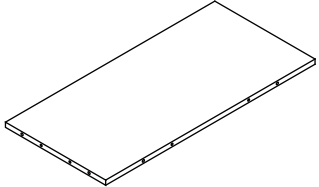
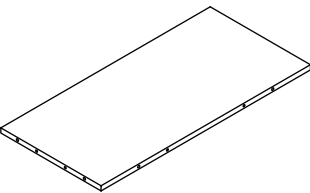
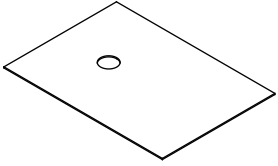
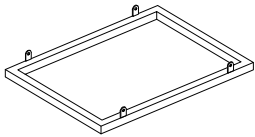





Parts and Operation Elements

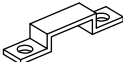

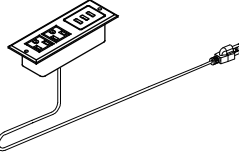
Parts and Operation Elements

			
①	1pc	②	1pc
			
③	1pc	④	1pc
			
⑦	1pc	⑧	1pc
			
⑪	1pc	⑫	1pc
			
⑮	2pcs	⑯	2pcs
			
⑲	1pc	⑳	1pc
		㉑	1pc

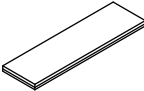
Hardware

			
Cam Bolt	15x12mm Cam Lock	Ø8x40mm Dowel	5x40mm Screw
(A) 64pcs ^{+2pcs}	(B) 64pcs ^{+2pcs}	(C) 45pcs ^{+2pcs}	(D) 12pcs ^{+2pcs}
			
M3x12mm Screw			
(E) 42pcs ^{+2pcs}	(F) 8pcs ^{+2pcs}	(G) 21pcs ^{+2pcs}	(H) 1pc
			
		M3x12mm Screw	M6x12mm Screw
(J) 1pc	(K) 1pc	(L) 2pcS	(M) 4pcs
			
			3x16mm Screw
(N) 64pcs ^{+2pcs}	(P) 16pcs ^{+2pcs}	(Q) 4pcs	(R) 4pcs

General instructions to assemble connecting pieces

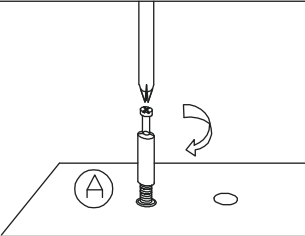
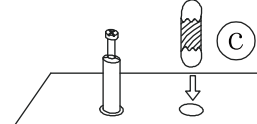
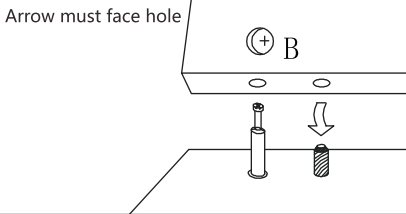
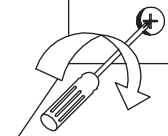
			
Gently screw cam bolt into the threaded anchor.	Insert the wood dowel halfway into hole.	Arrow must face hole	Screw the camlock firmly into locked position.

1

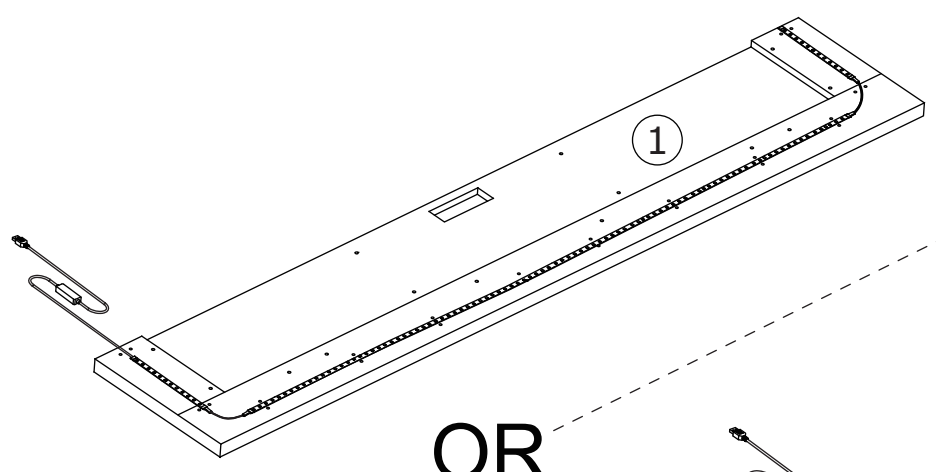
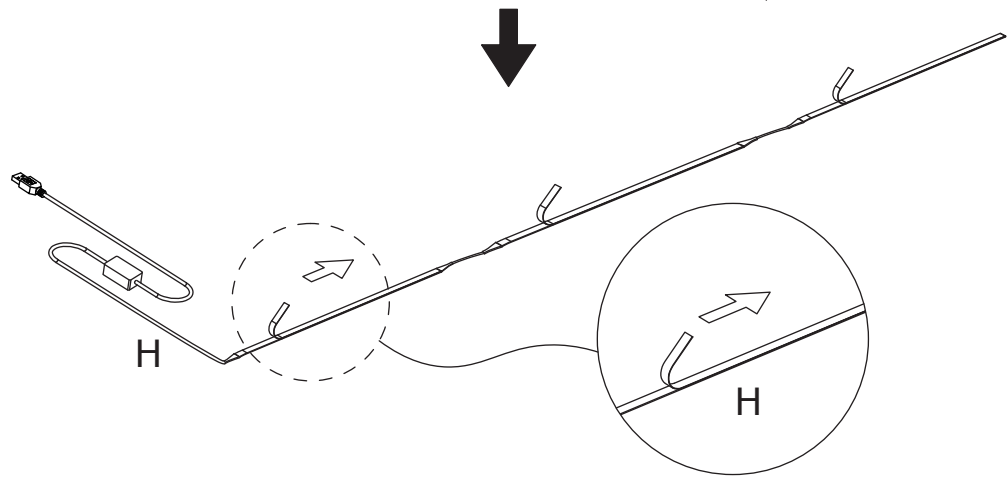
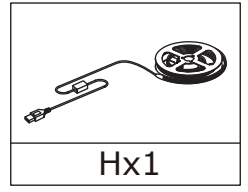
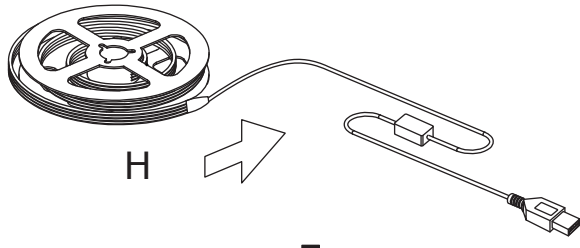

OR

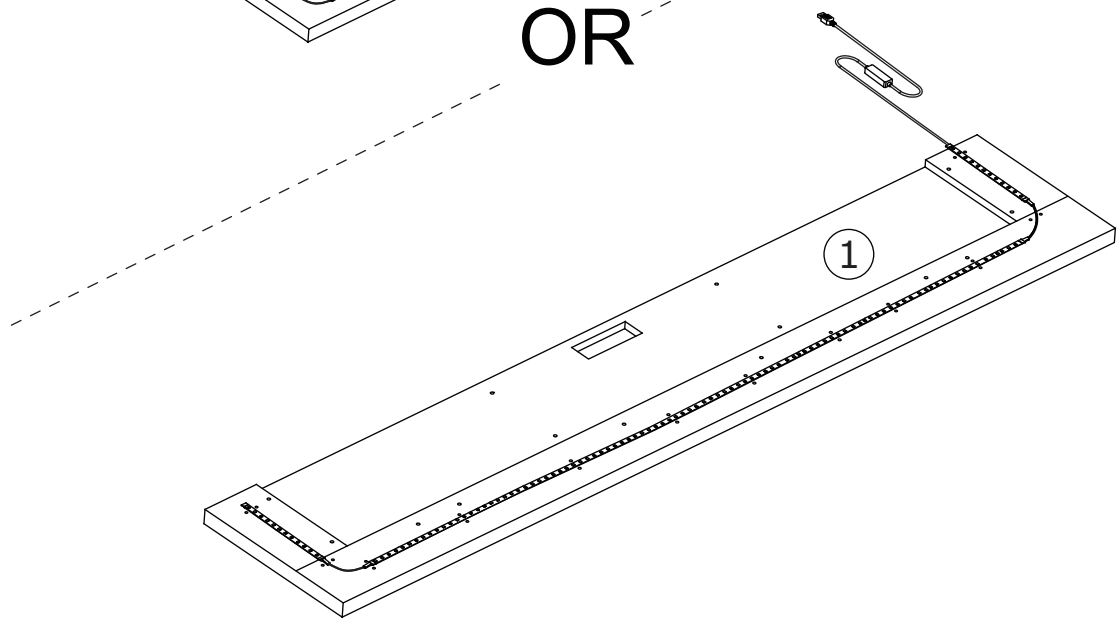

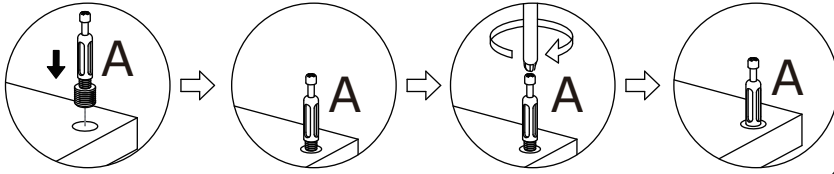

2

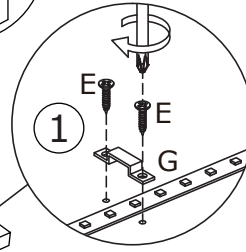

Before assembly, tear off the film of plates 1, 2 and 7.



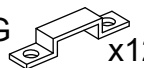

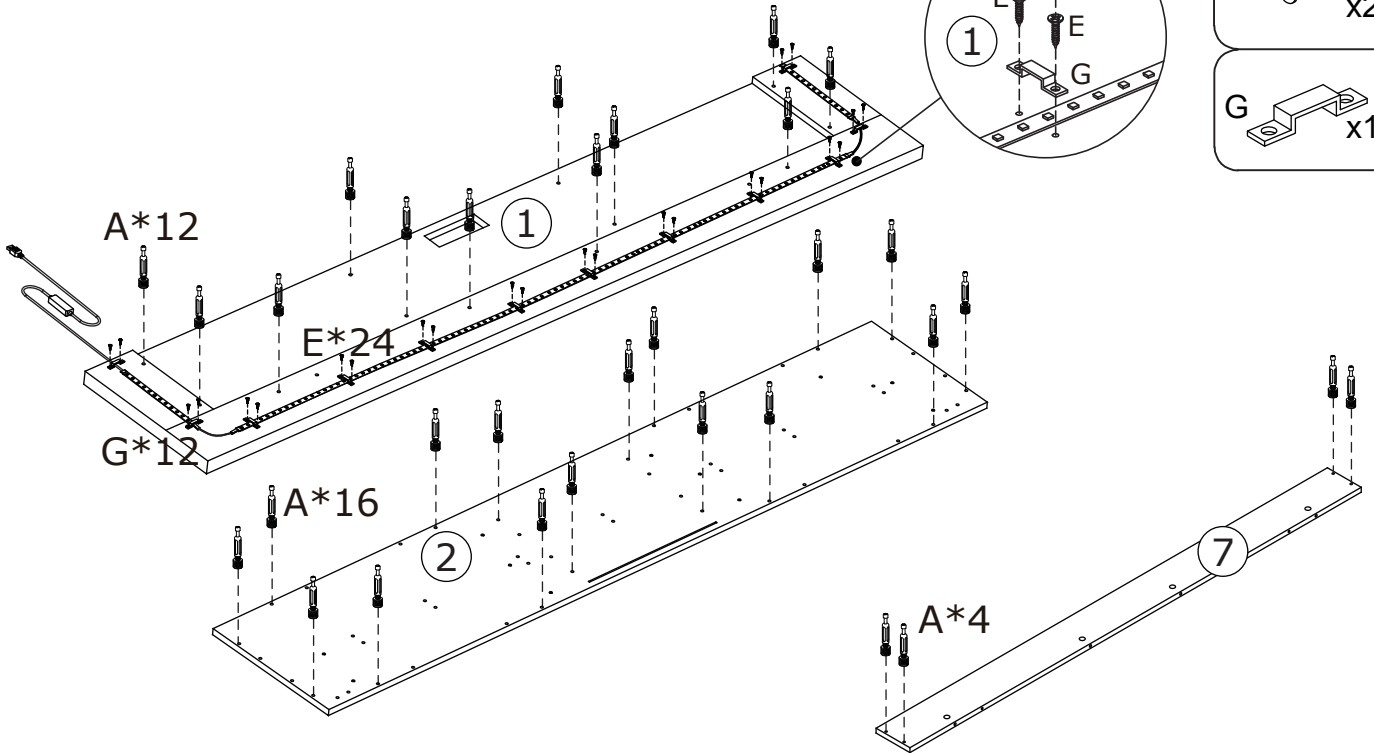

- A  x32
- E  x24
- G  x12

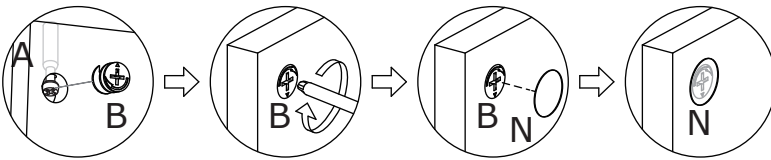

3



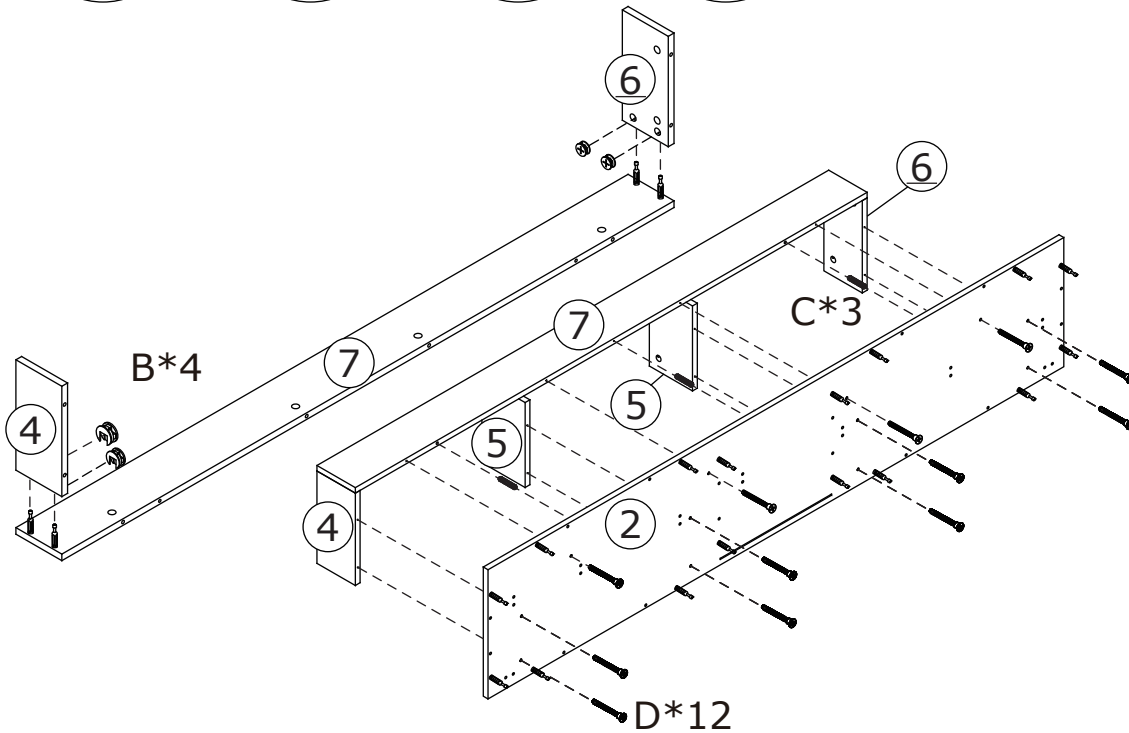

- B  x4
- C  x3
- D  x12
- N  x4

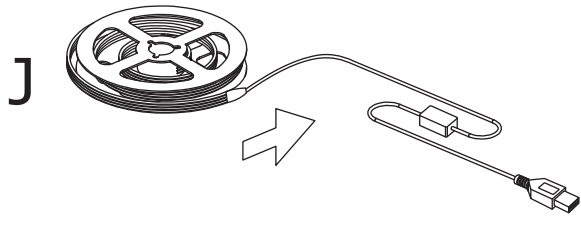

4

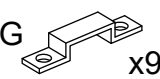

- J  x1
- E  x18
- G  x9

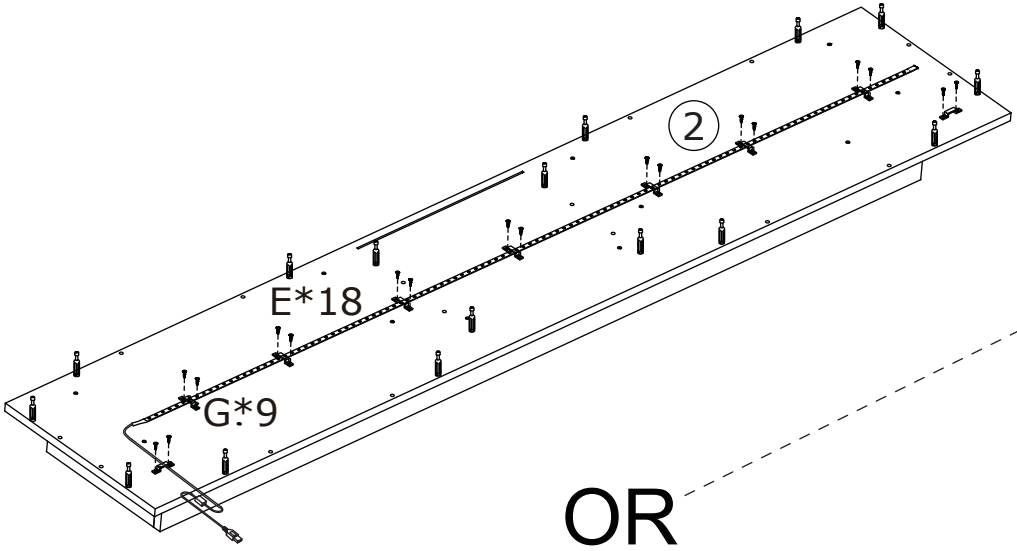
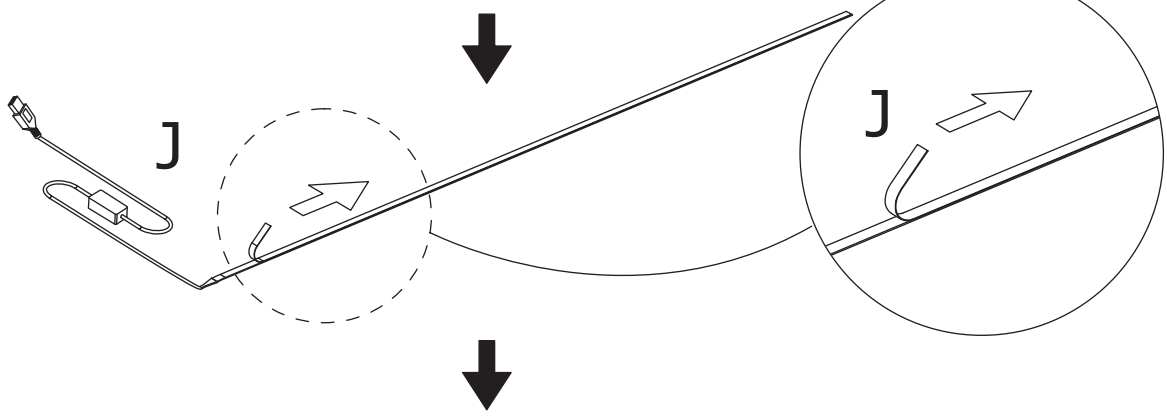

OR

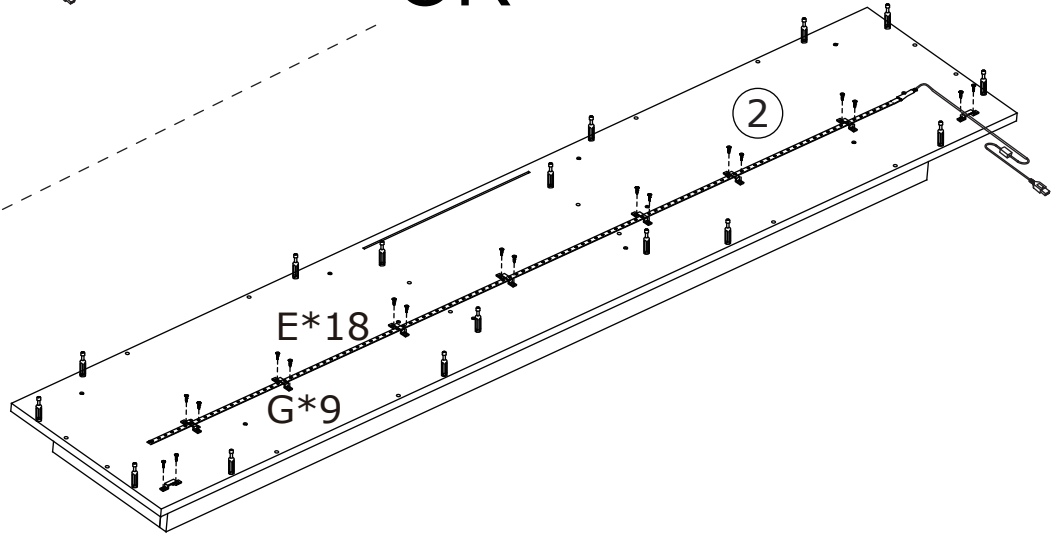

5

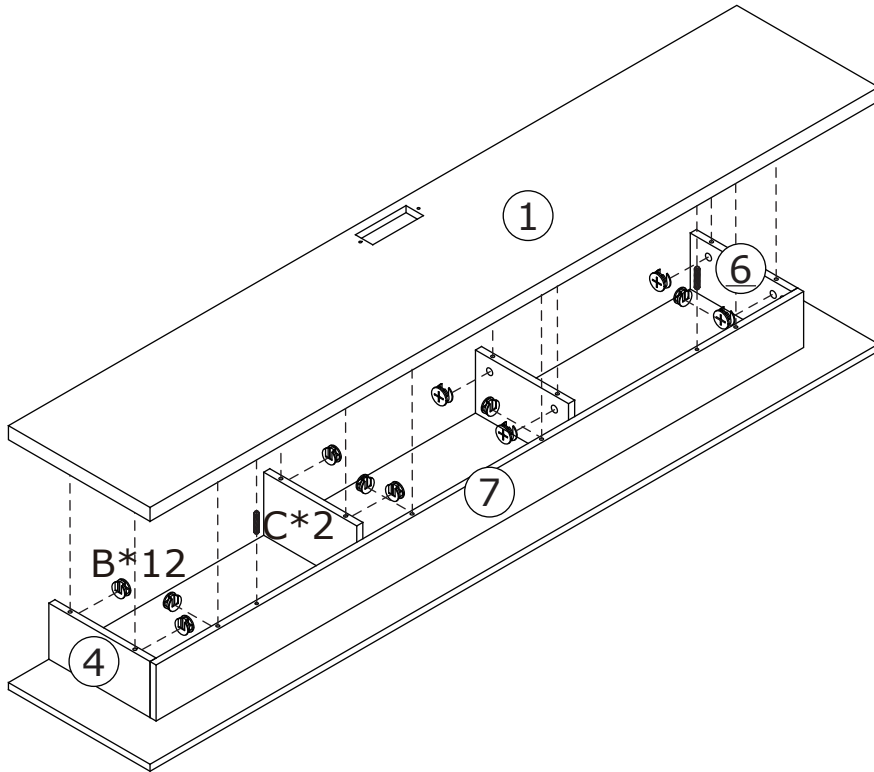
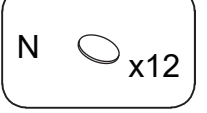
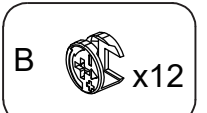
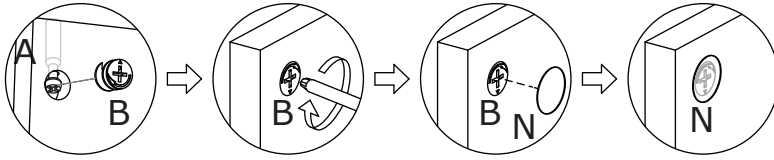

6

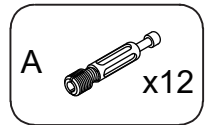
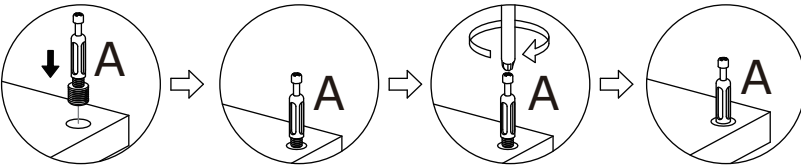

Before assembly, tear off the film of plates 12, 13 and 16.

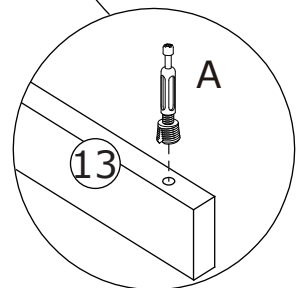
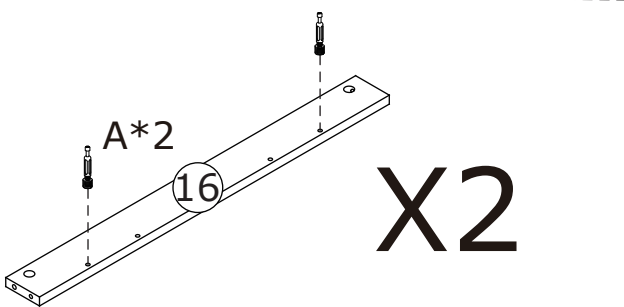
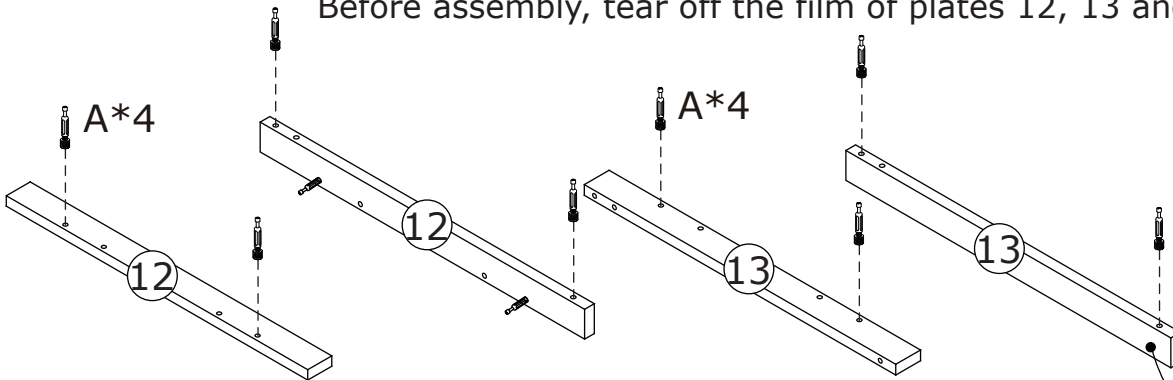

7

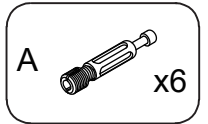
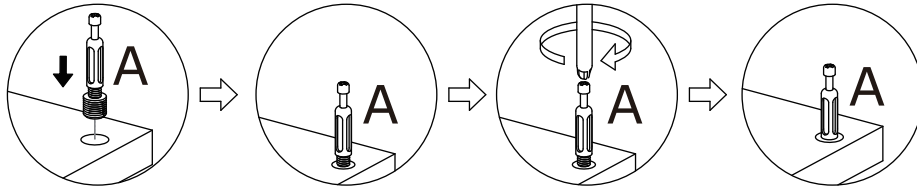

Before assembly, tear off the film of plates 8 and 11.

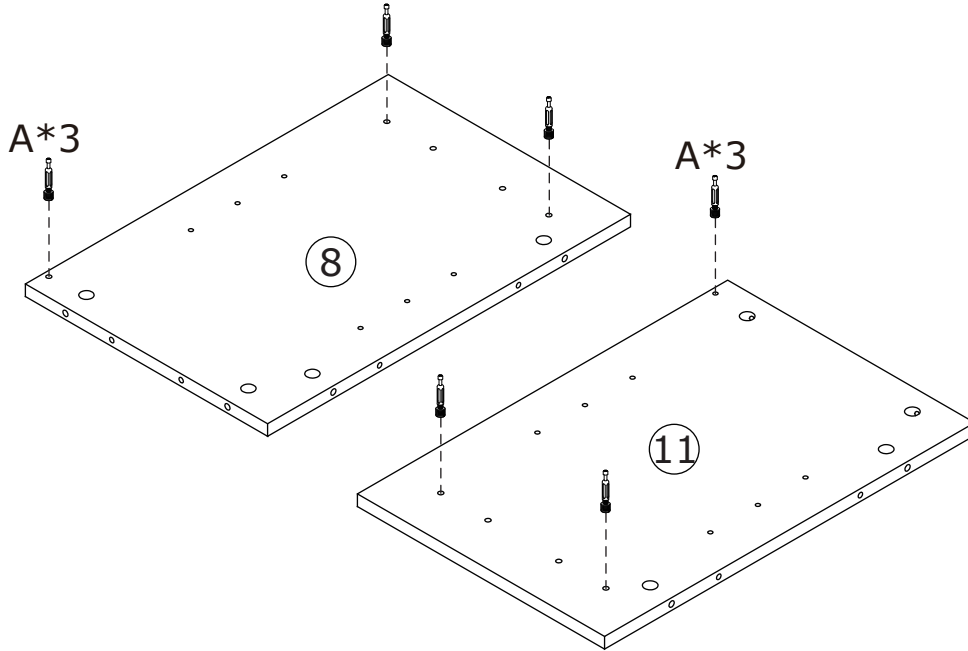

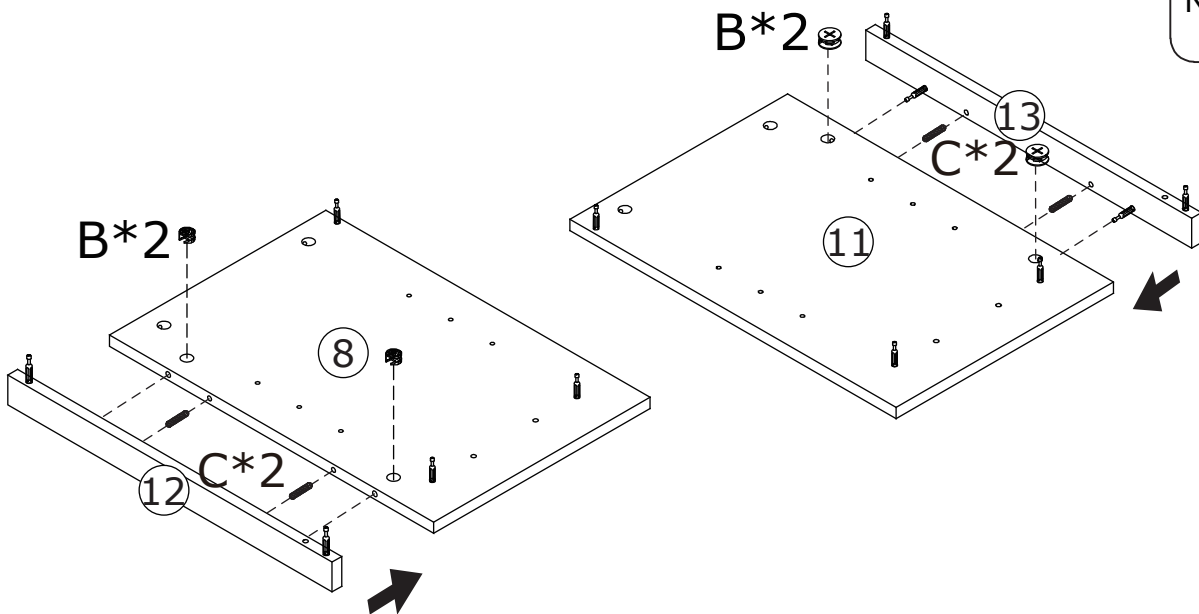
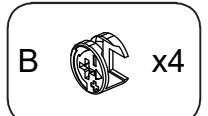
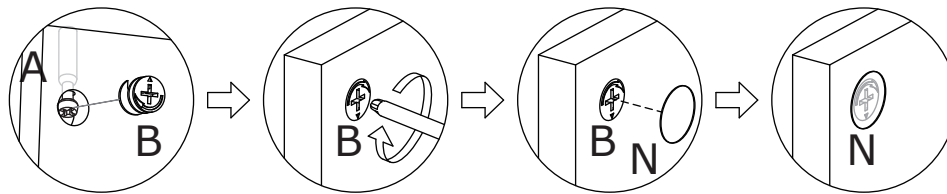

8

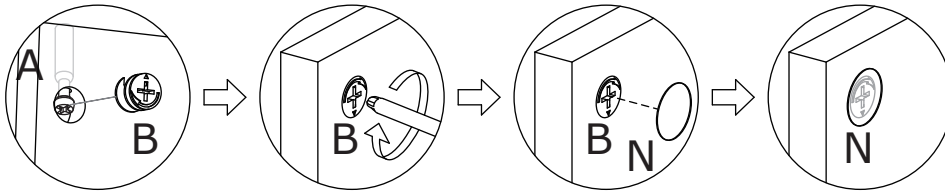

9



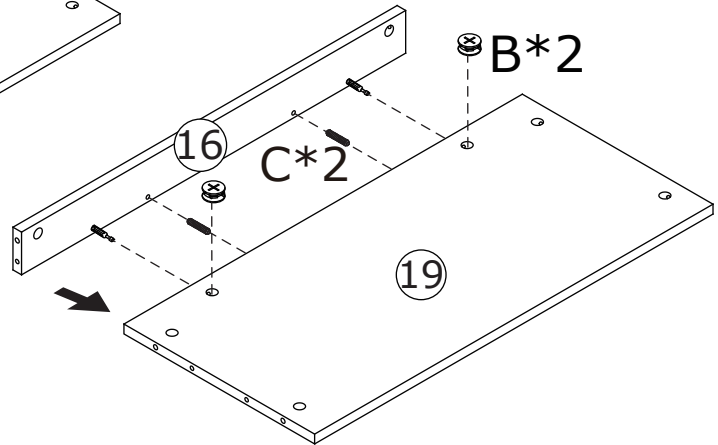
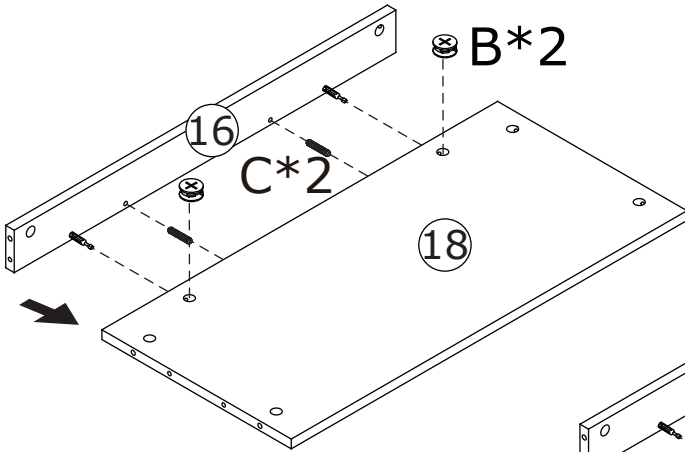

- B  x4
- C  x4
- N  x4

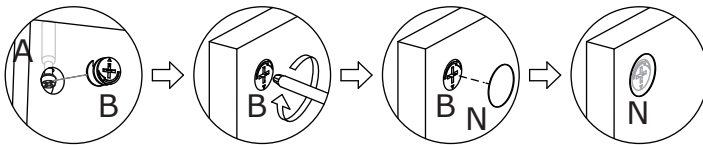

10



- B  x8
- C  x6
- N  x8

Before assembly, tear off the film of plates 17.

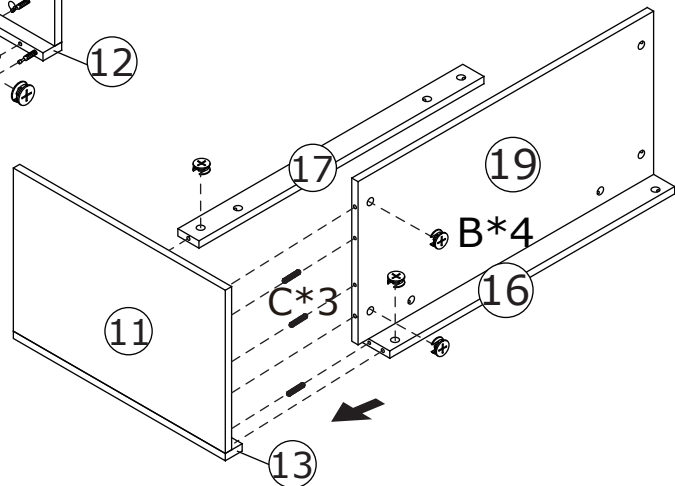
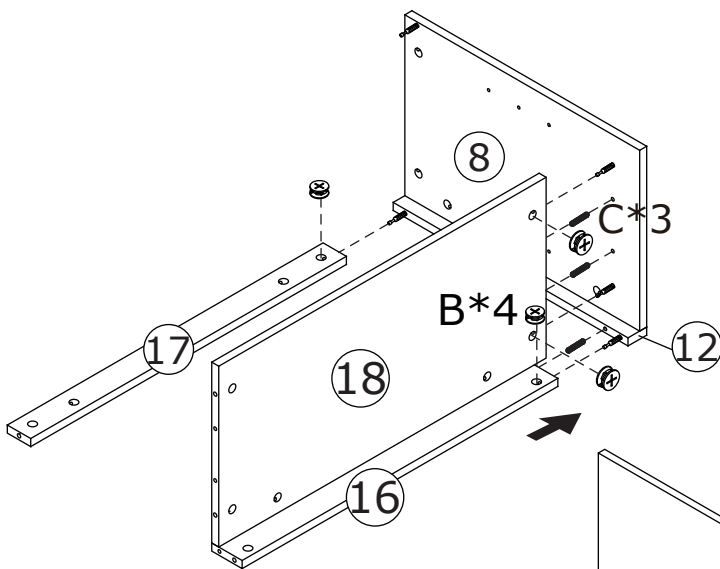

11

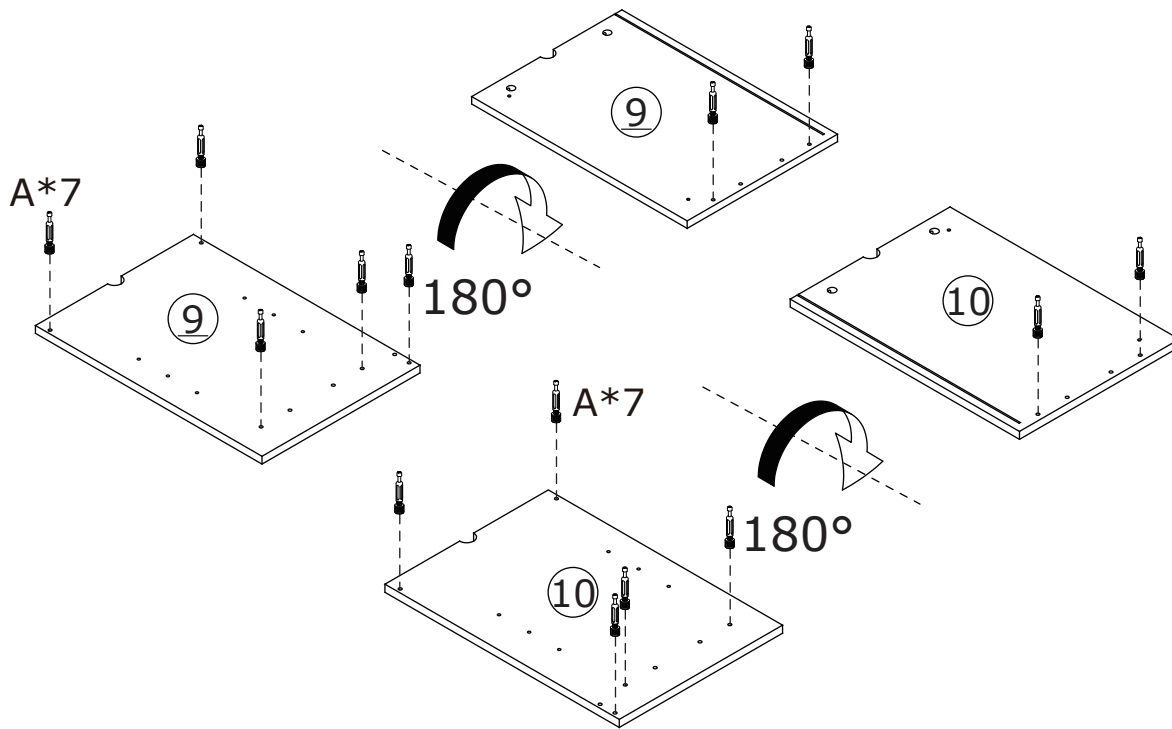
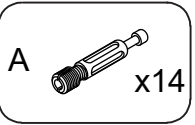
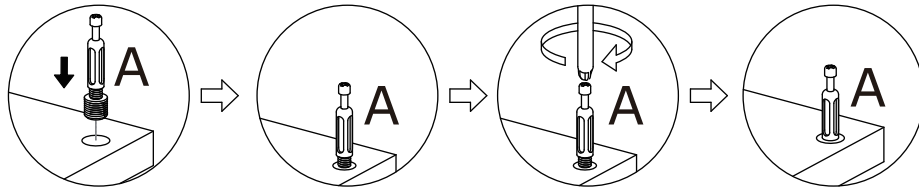

12

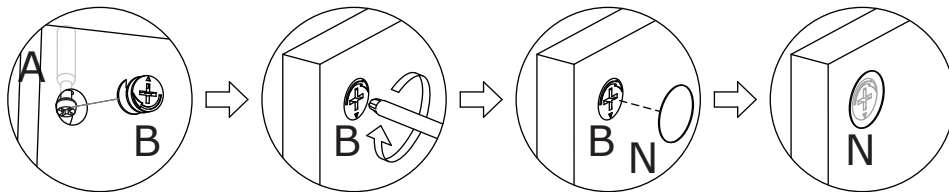

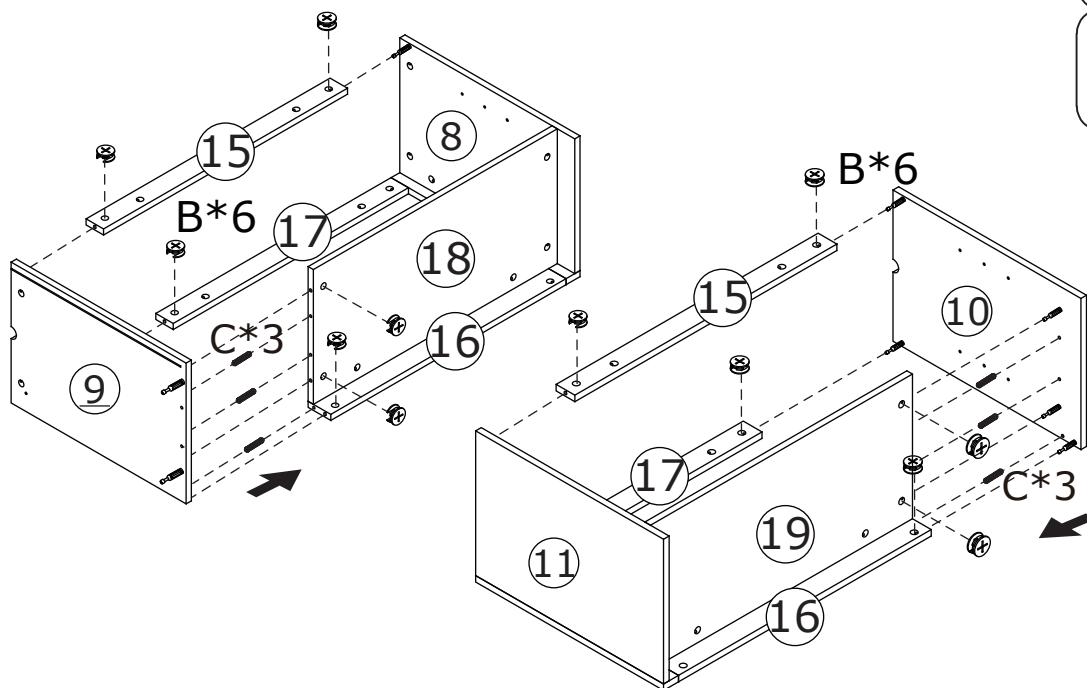
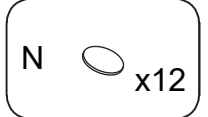
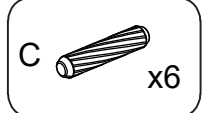
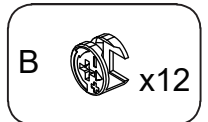

The hole of B accessories is facing up.

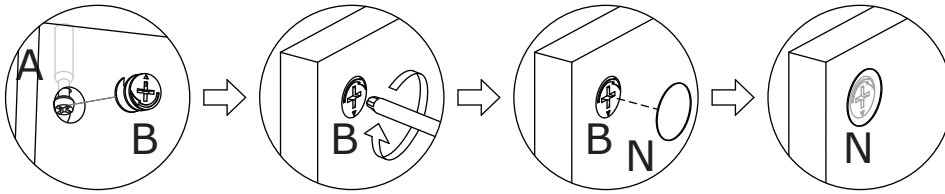

13





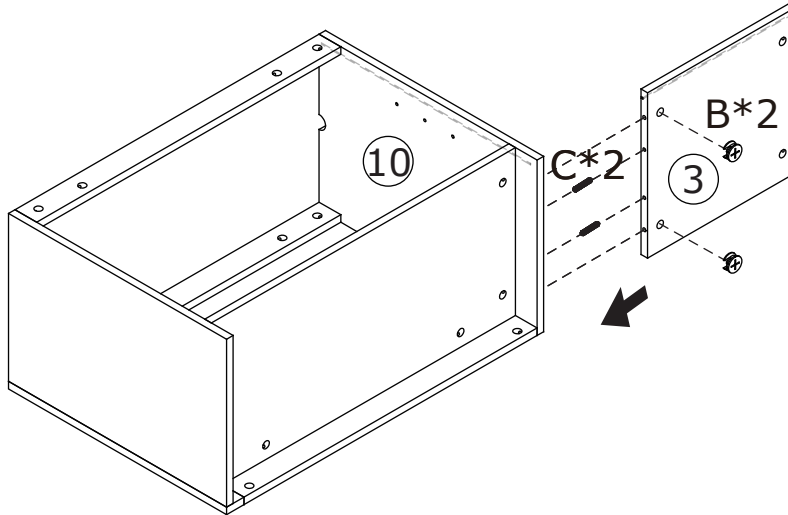

- B  x2
- C  x2
- N  x2

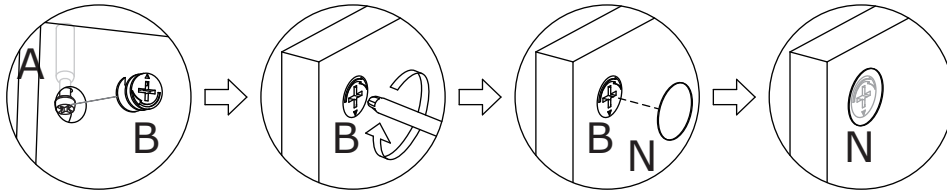

14



- B  x2
- C  x2
- N  x2
- P  x16

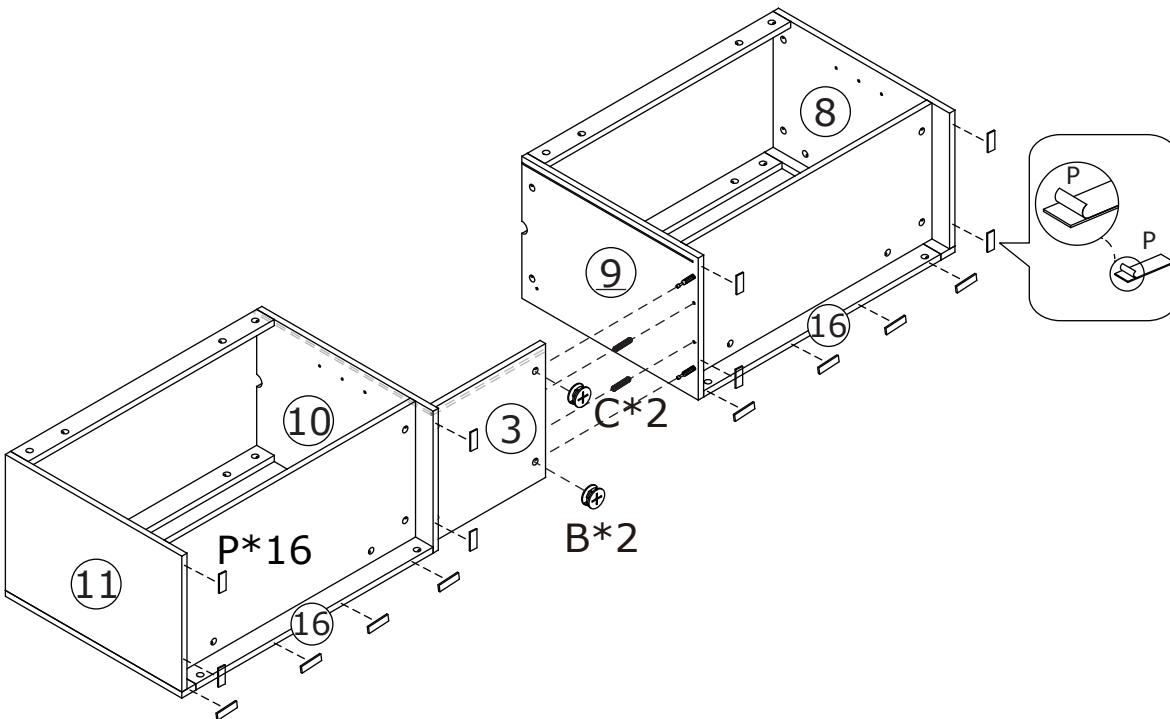

15

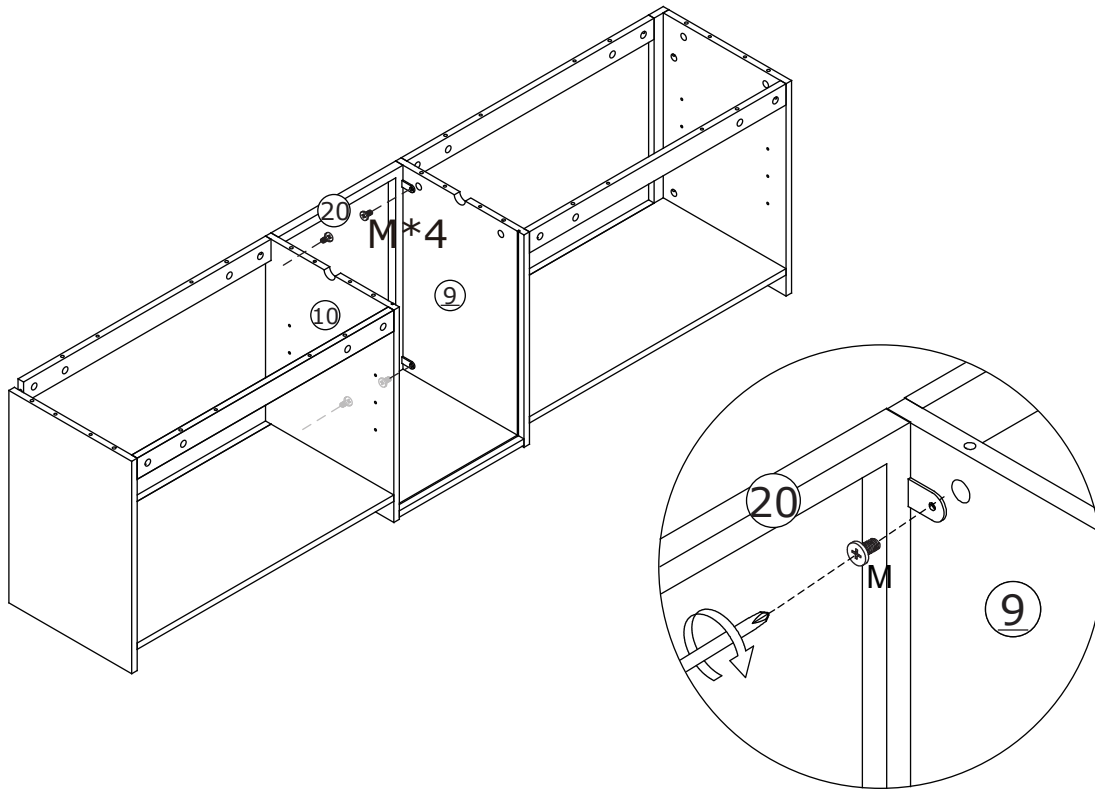
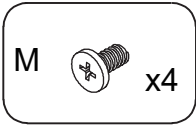

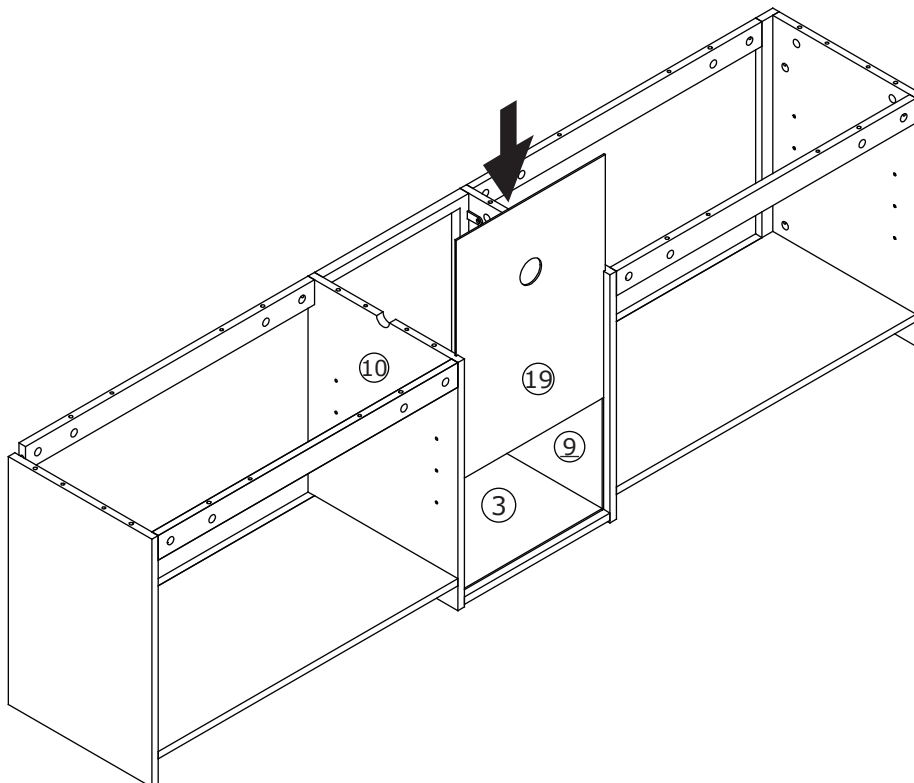

16

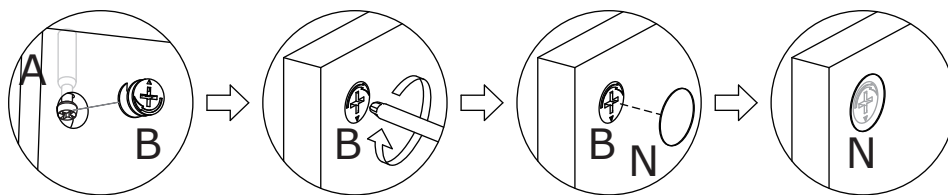

17



- B  x16
- C  x16
- N  x16

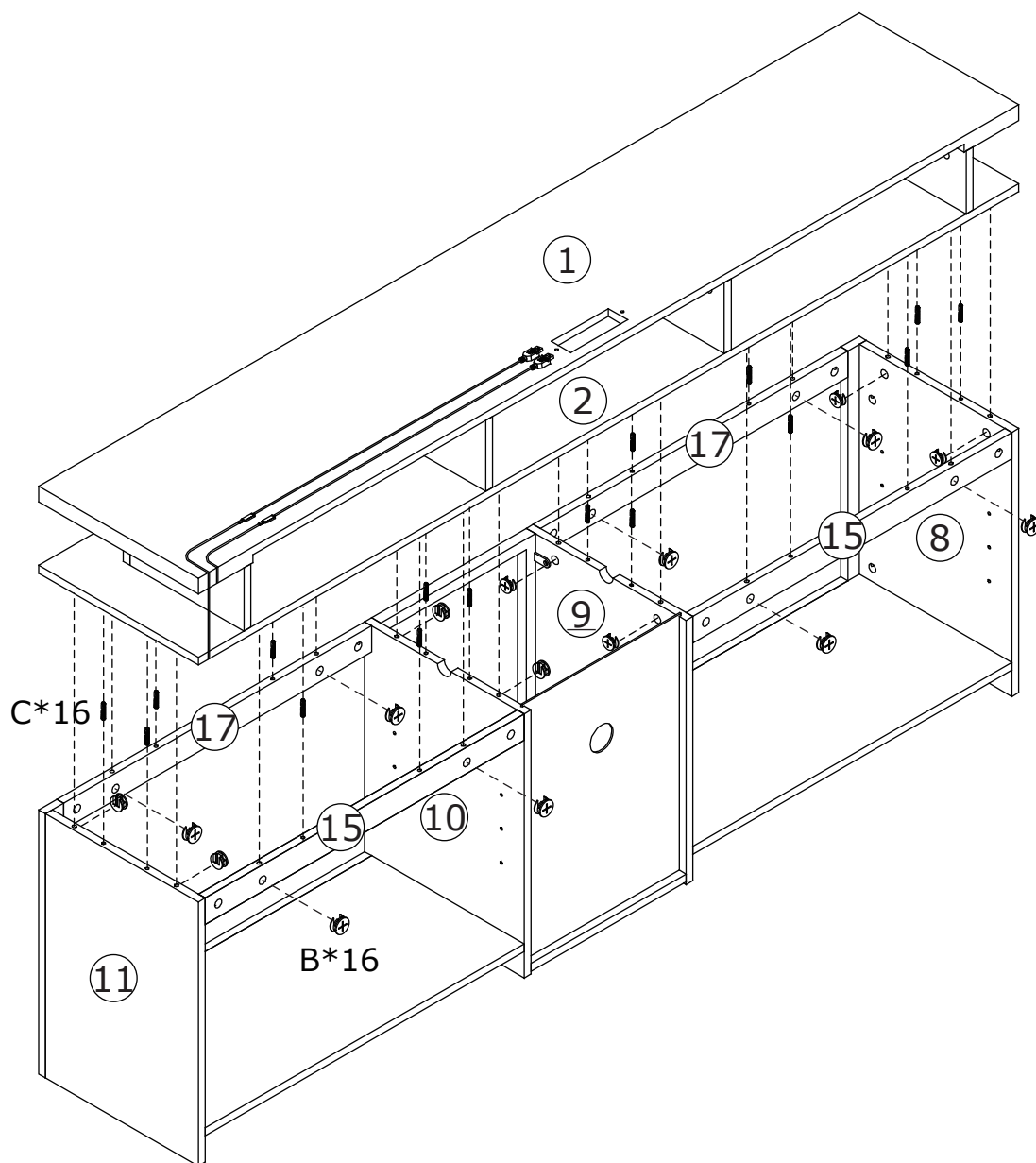

18

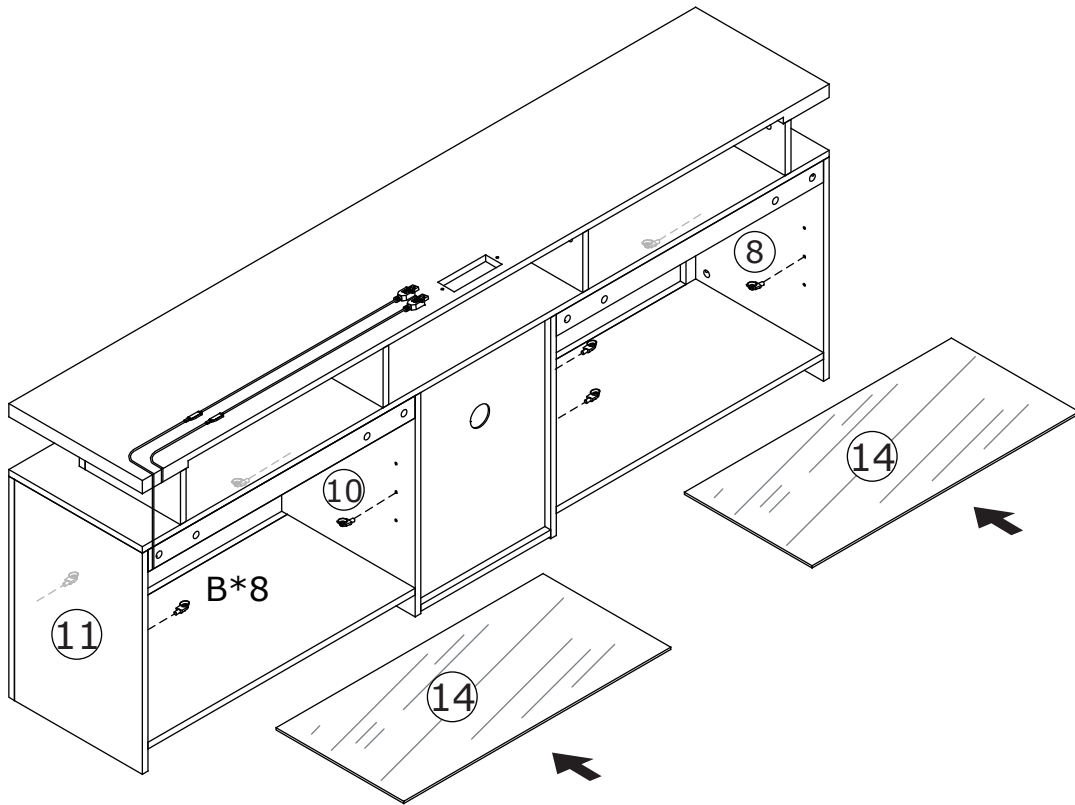
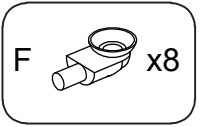

19

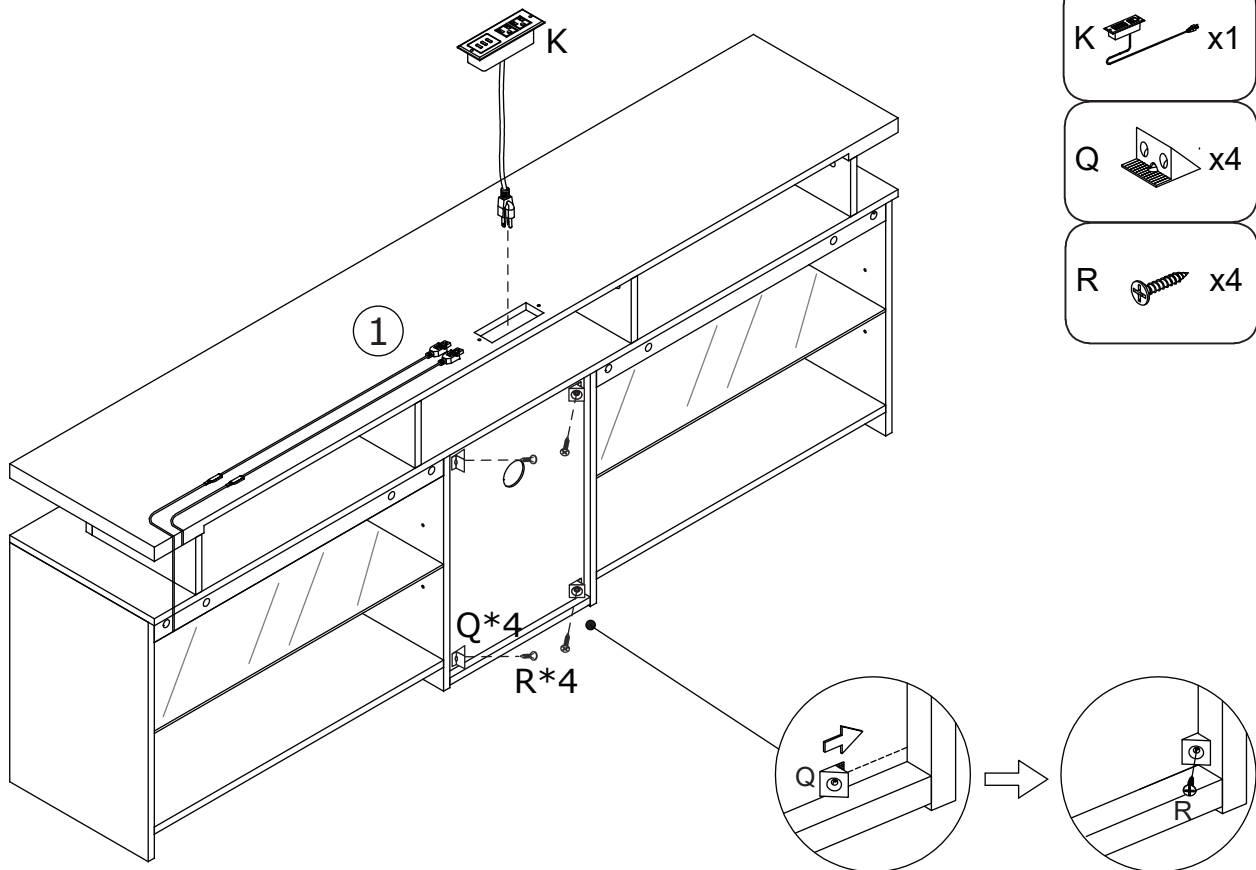
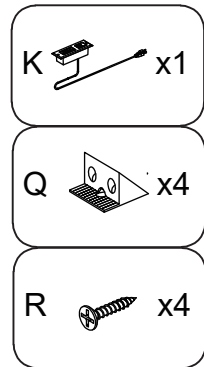

20

L  x2

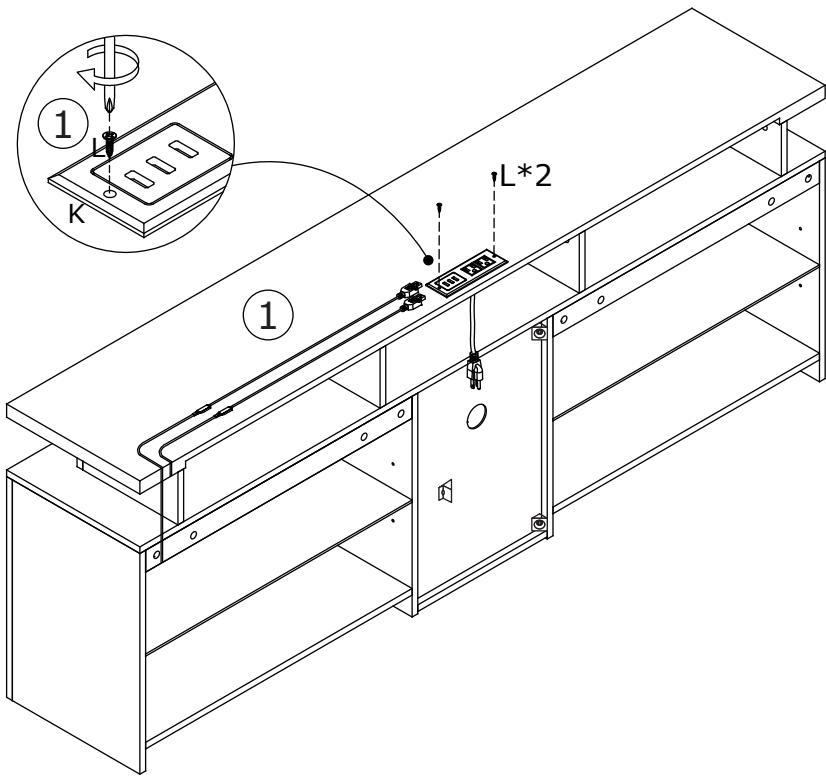

21

