

ASSEMBLY INSTRUCTION

If there are any questions during the assembly process.

A video and description about the step you were stucked will help us to understand the problem quickly.

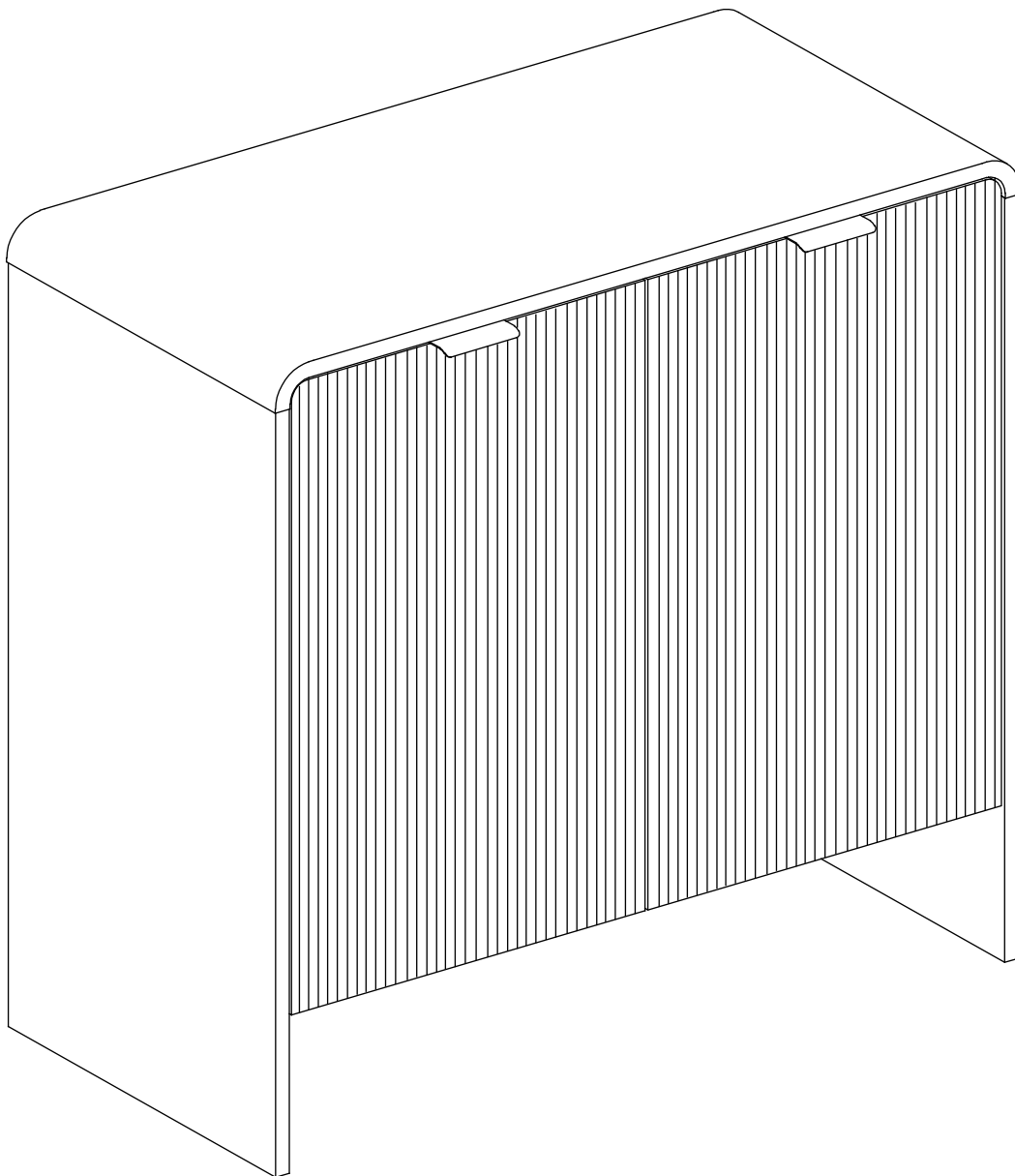

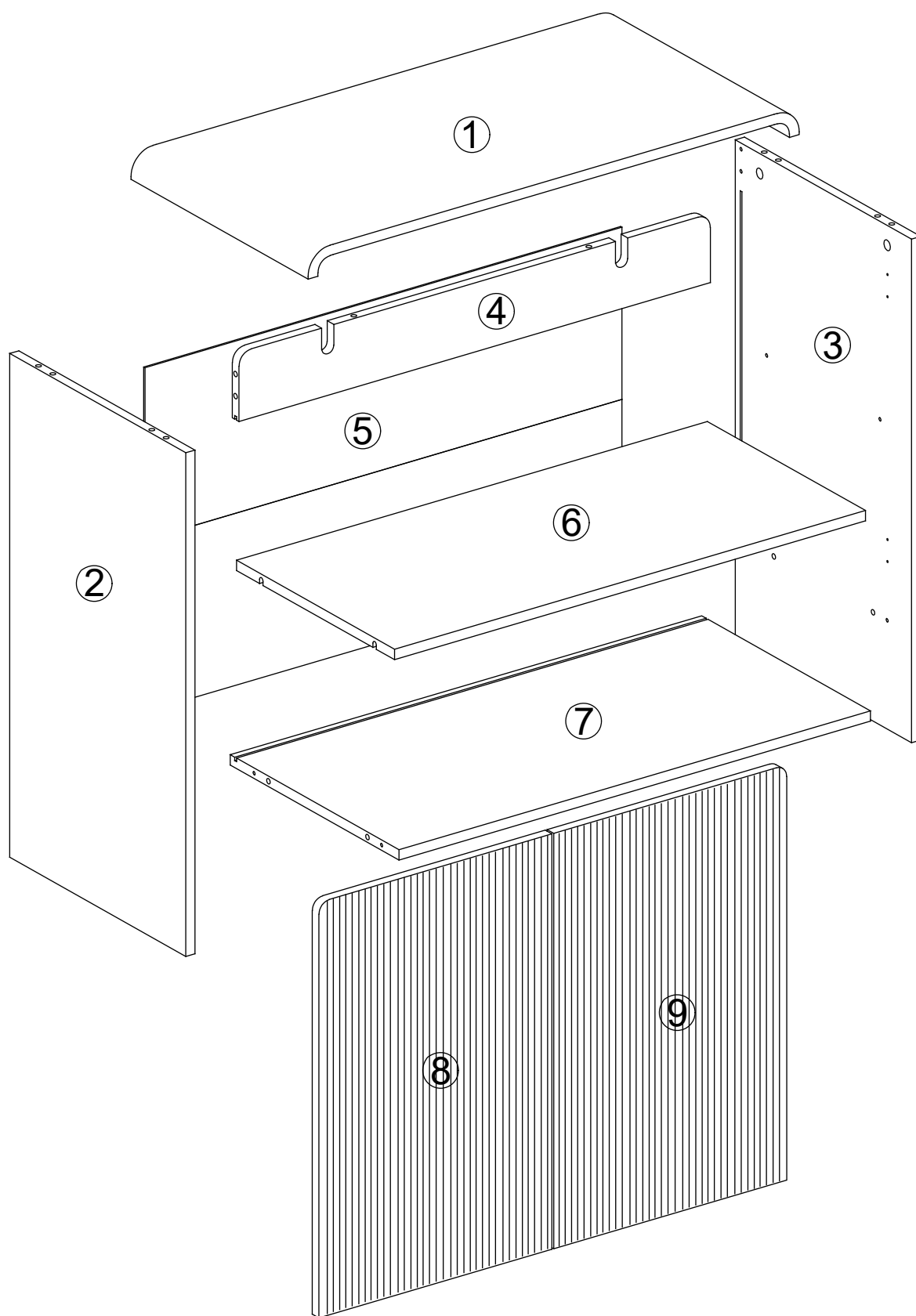

① x1

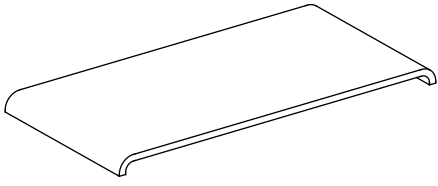

② x1

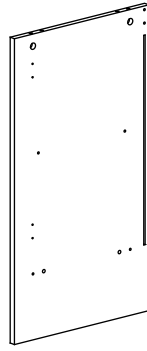

③ x1

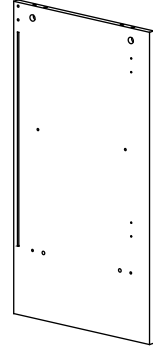

④ x1

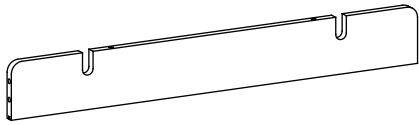

⑤ x1



⑥ x1

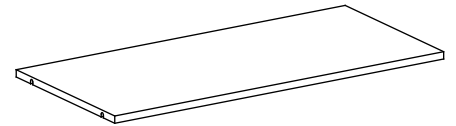

⑦ x1

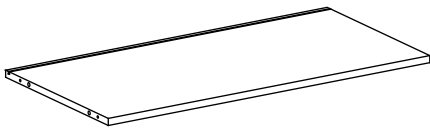

⑧ x1

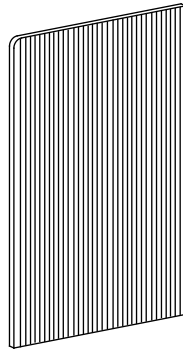

⑨ x1

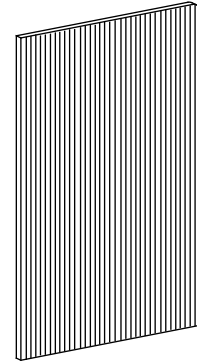

A

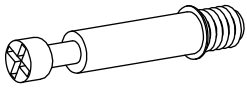

Ø6x35mm

X18+2 pcs

B



Ø15x9.5mm

X18+2 pcs

C



Ø8x30mm

x 8 pcs

D

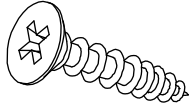

Ø3x12 mm

x 4 pcs

E

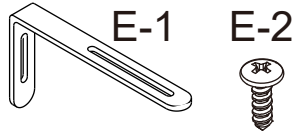

x 2 pc

F

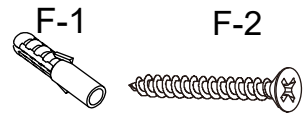

x 2 pcs

G

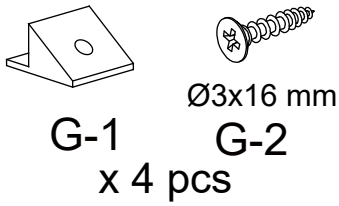

Ø3x16 mm

G-1
x 4 pcs

G-2

H

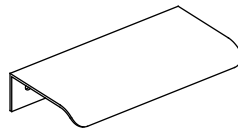

x 2 pcs

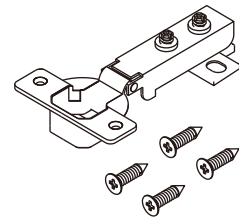

J

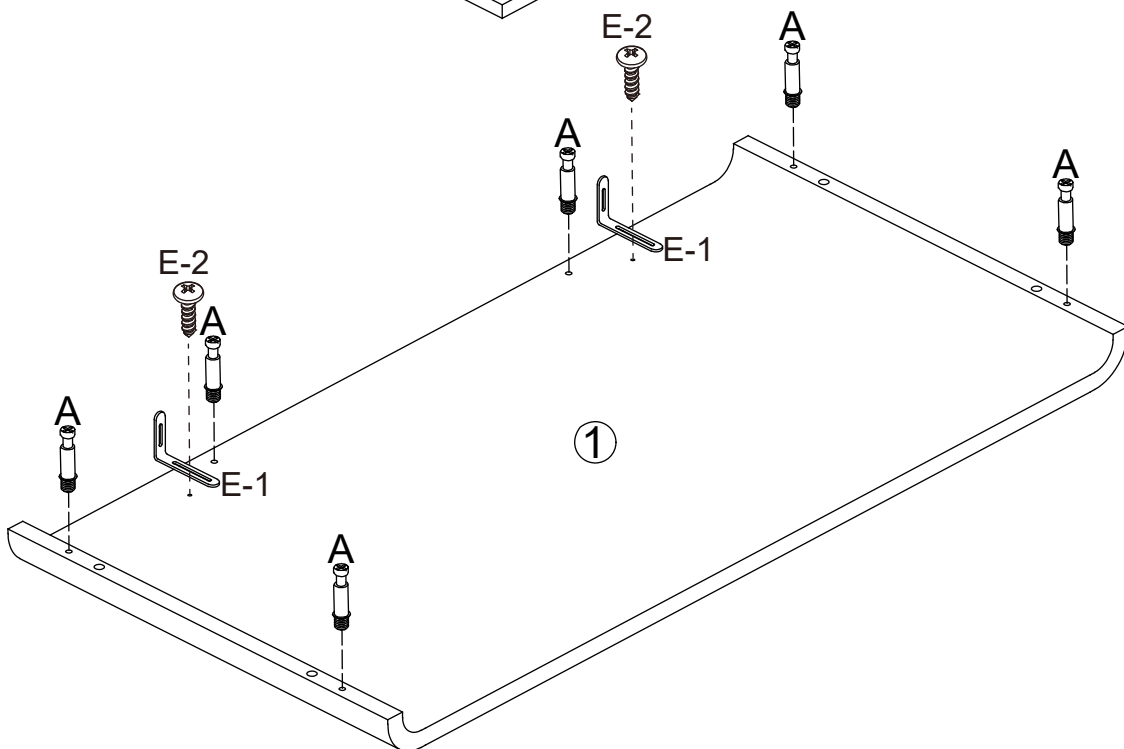
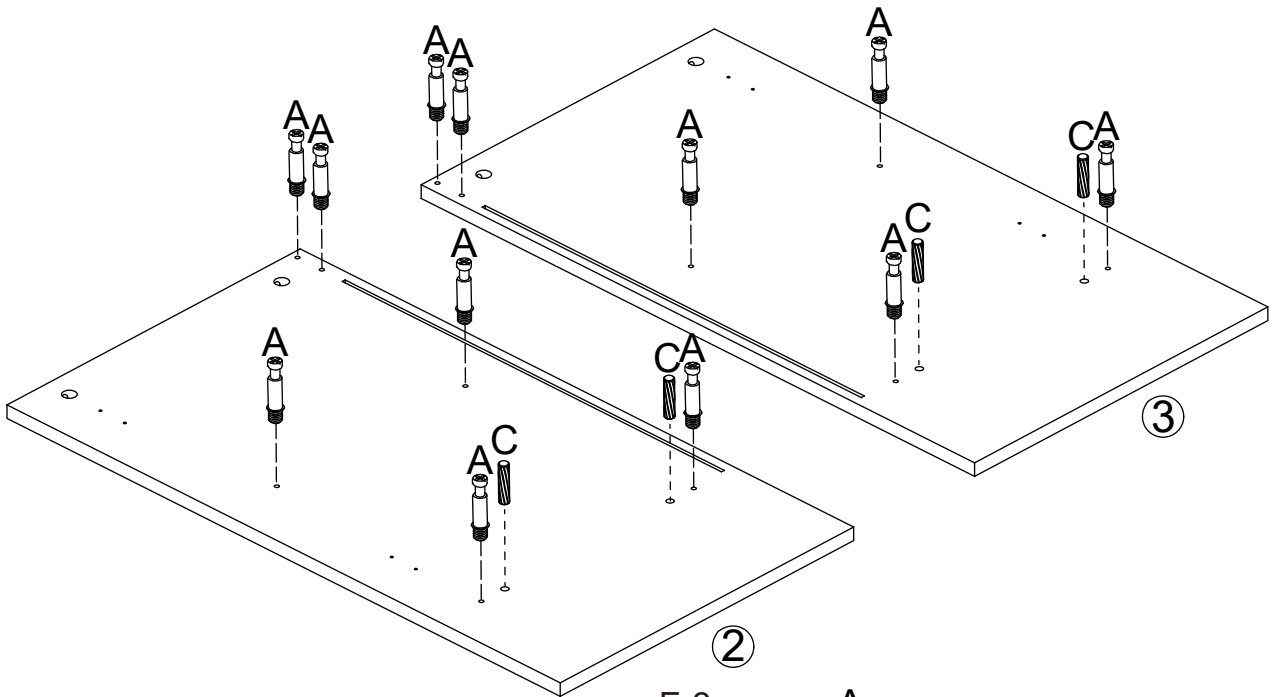
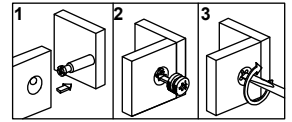

x 4 pcs

SETP 1

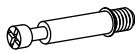

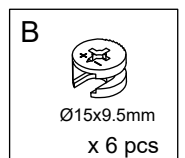
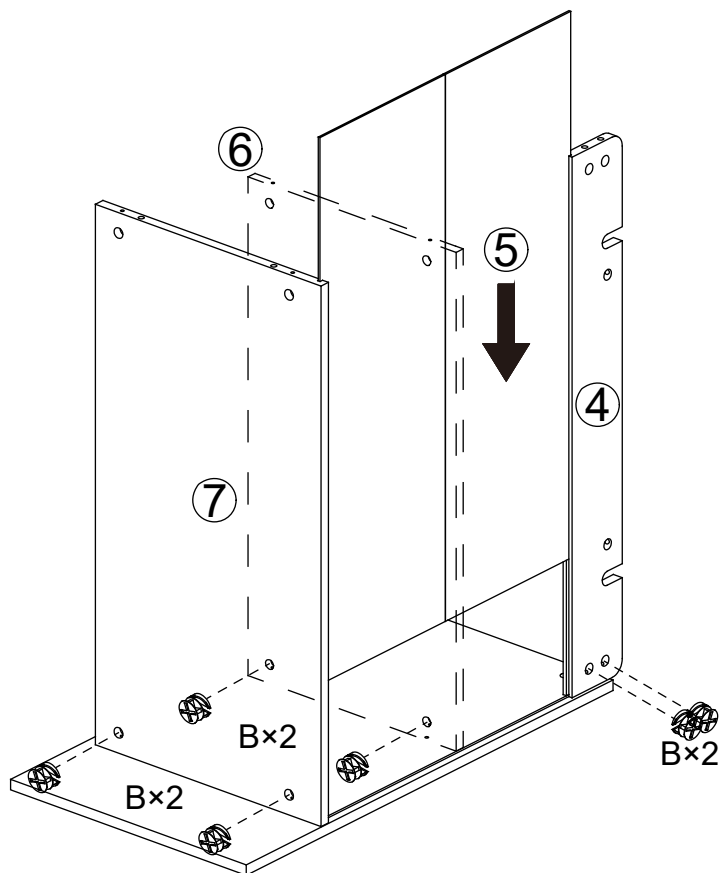
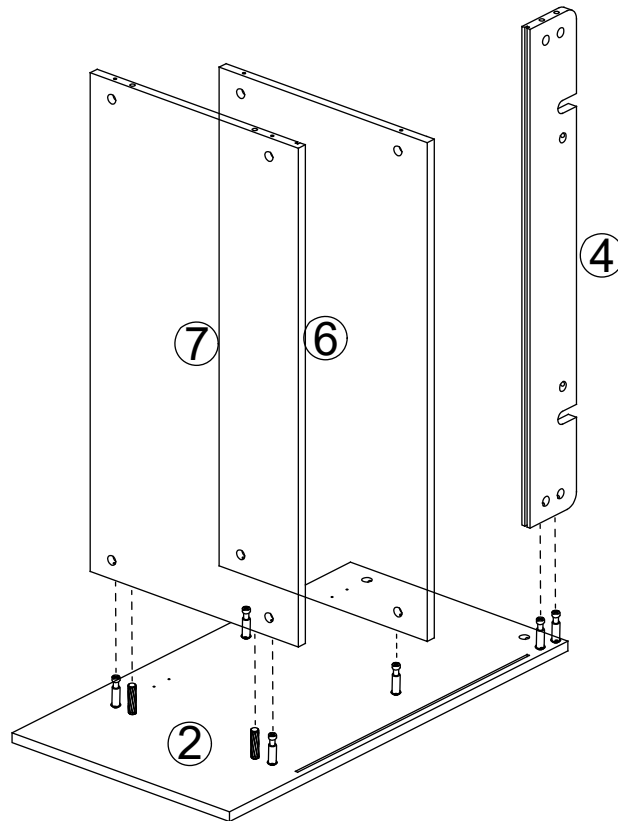
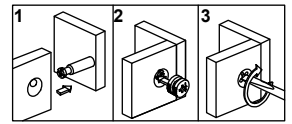

A  x 18 pcs	C  Ø6x30mm x 4 pcs	E  E-1 E-2 x 2 pc
---	---	--

SETP 2



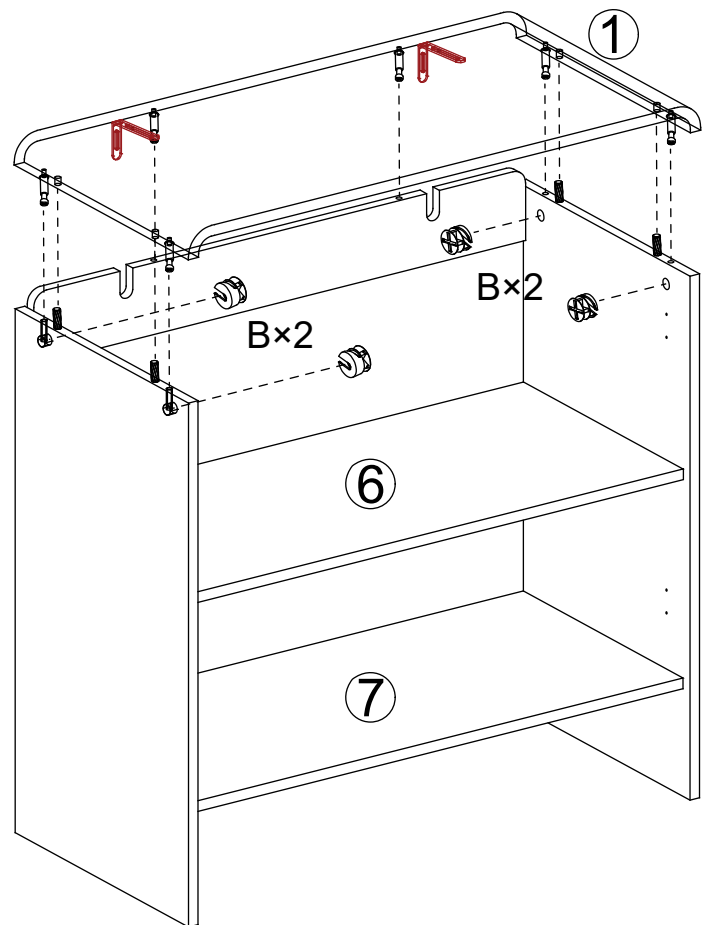
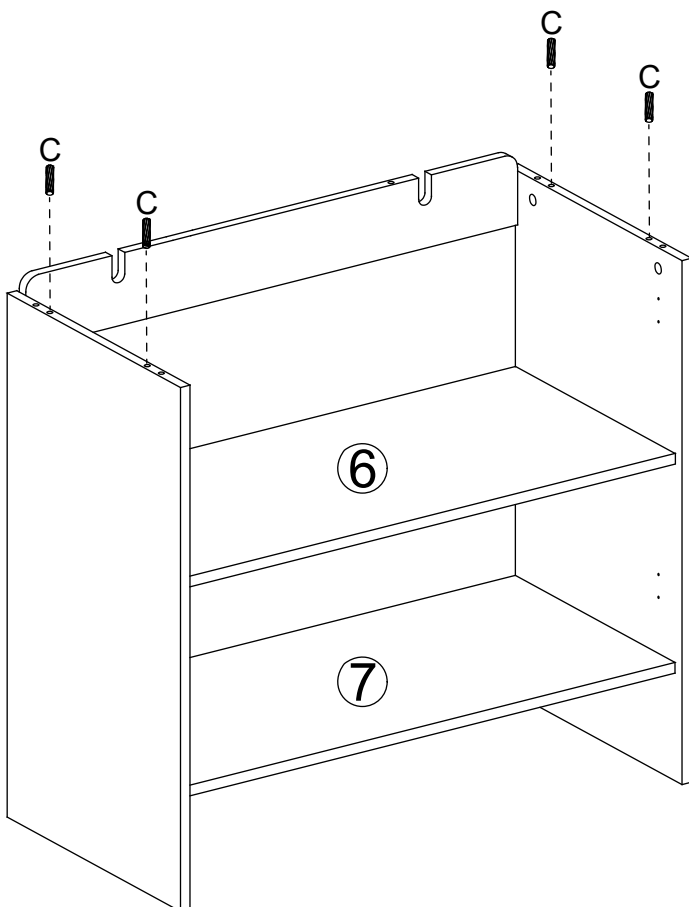
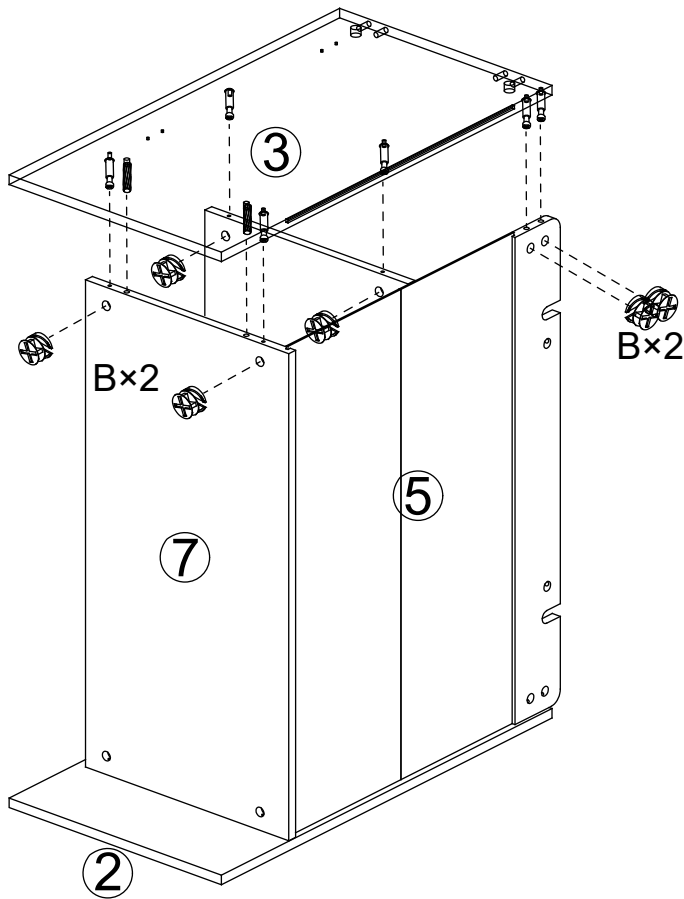
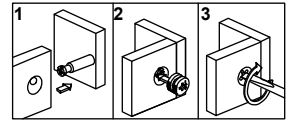



SETP 3

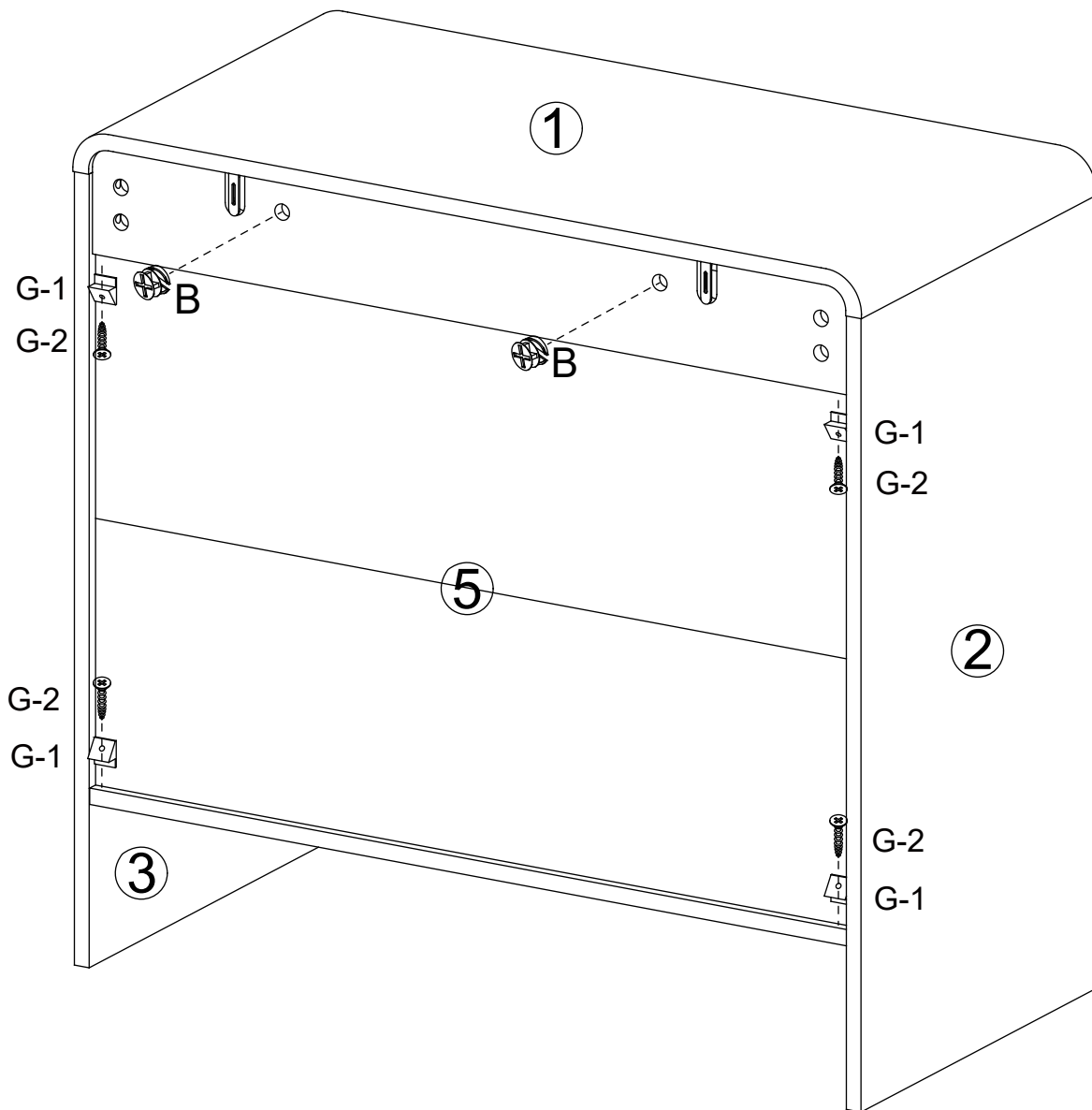

C  Ø8x30mm x 4 pcs	B  Ø15x9.5mm x 10 pcs
---	--

SETP 4



B  Ø15x9.5mm x 2 pcs	G   G-1 Ø3x16 mm G-2 x 4 pcs
---	---

STEP 5

WALL

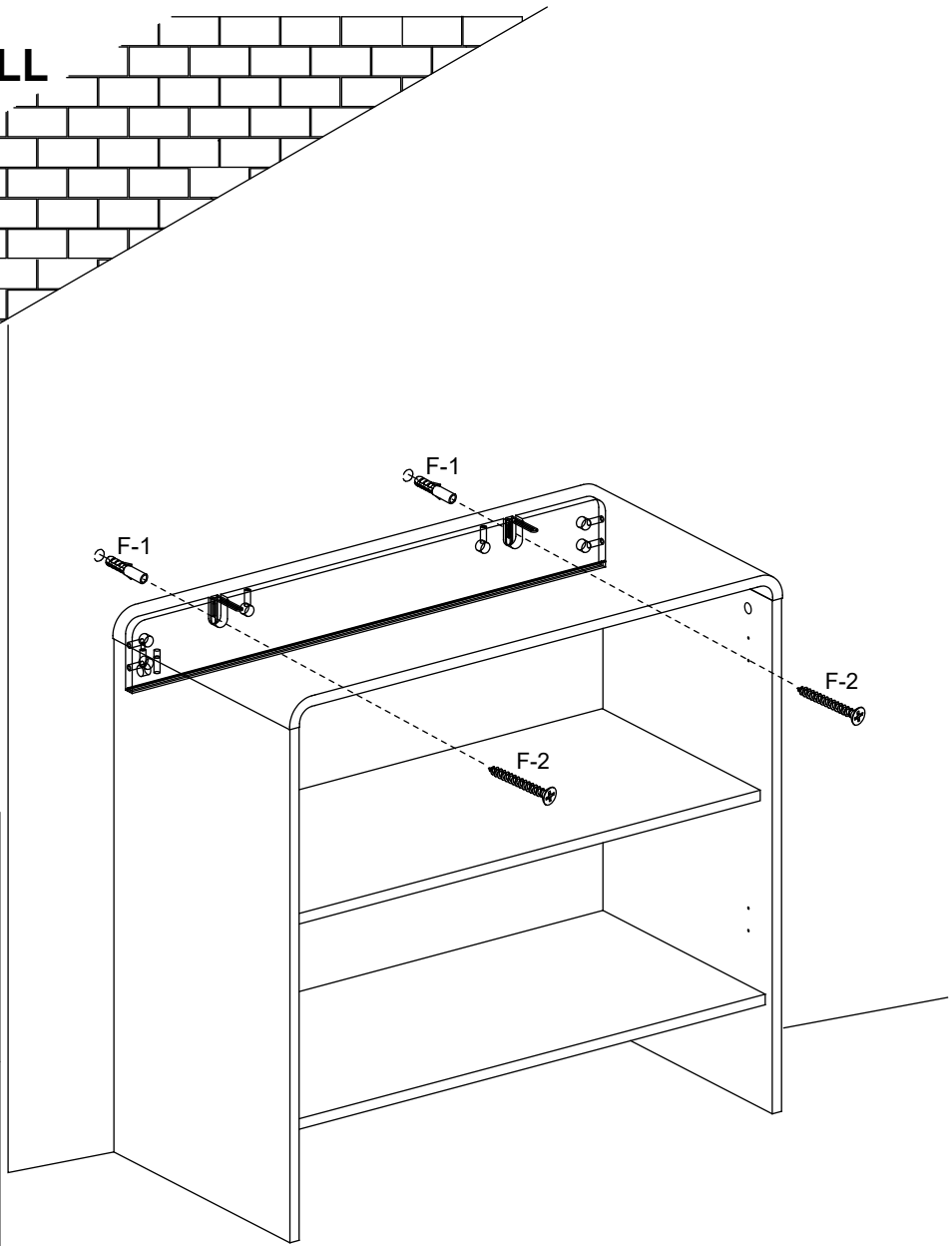
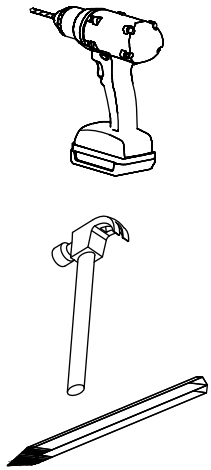

WALL

I x2

WALL +
drilling hole
Ø6x30mm

II x2

WALL

F-1

III x2



F

F-1 **F-2**

x 2 PCS

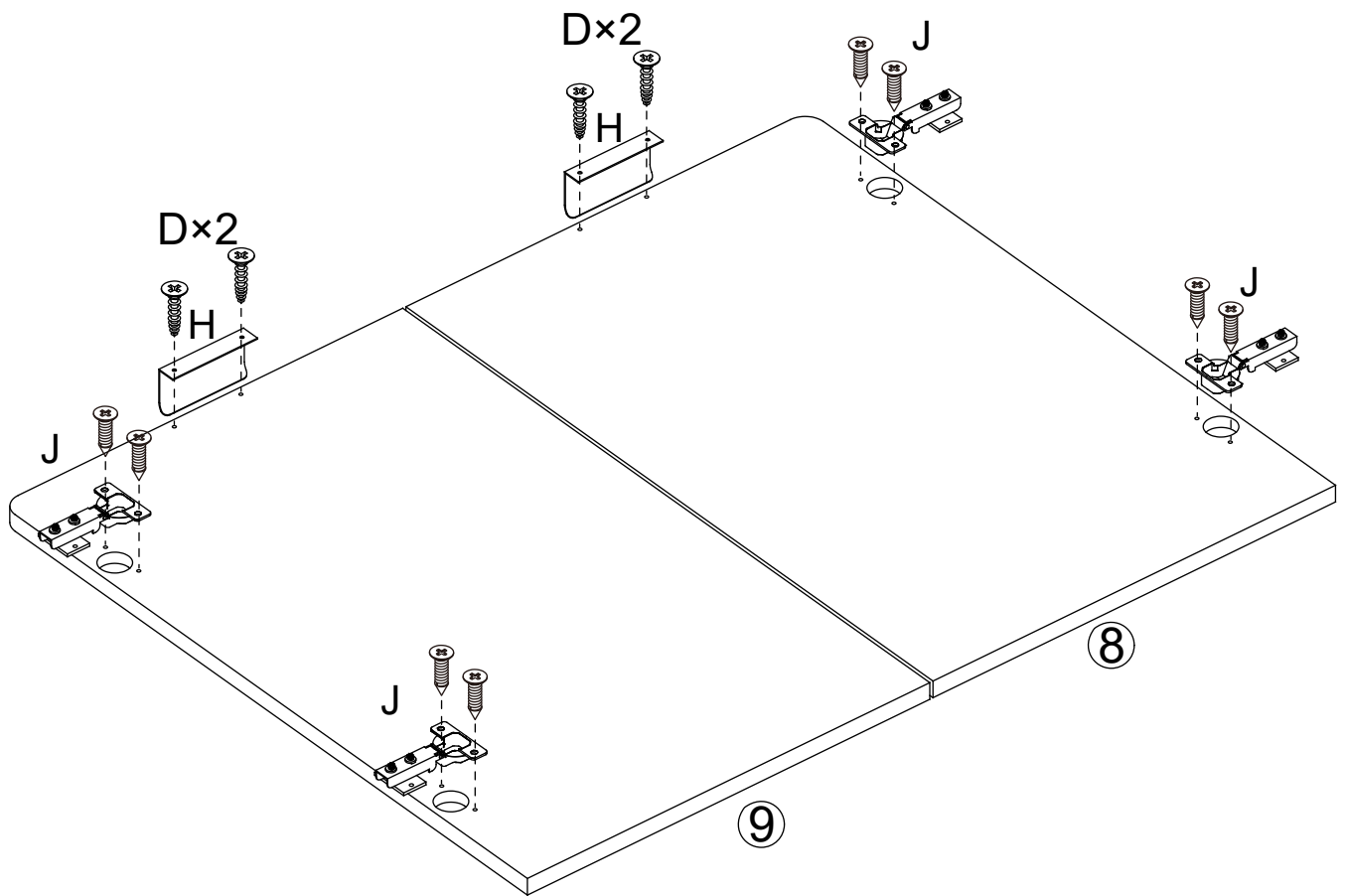
SETP 6



<p>H</p>  <p>x 2 PCS</p>	<p>D</p>  <p>Ø3x12 mm x 4 pcs</p>	<p>J</p>  <p>x 4 pcs</p>
--	---	--

STEP 7

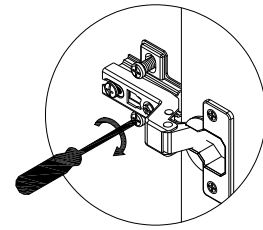
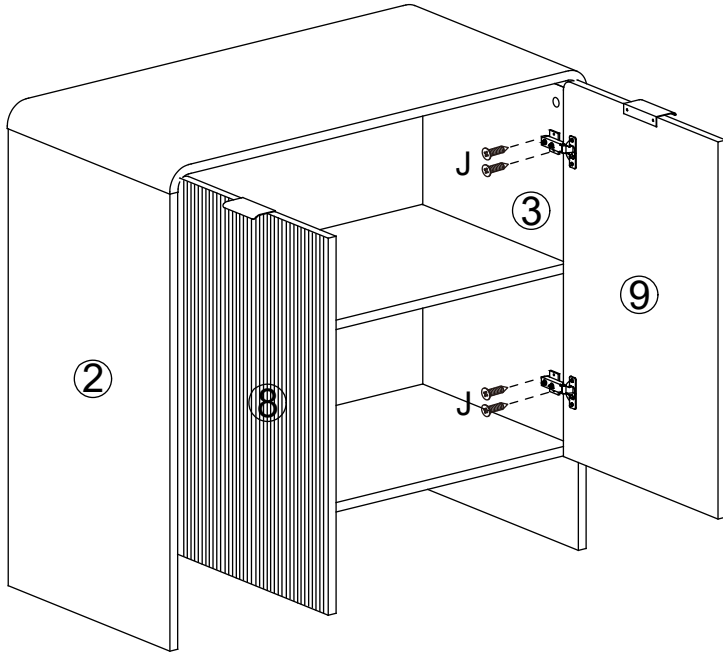

Align the screws with the reserved holes, adjust the position of the door up and down, and then tighten the screws.

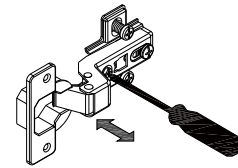

Adjust the left and right position of the door by rotating the screws counterclockwise or clockwise.

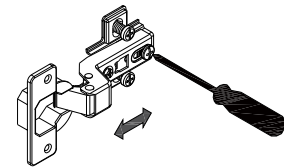

Loosen the screws, move the position of the door forward and backward. Then tighten the screws.

