

Assembly Guide

Contents

English - - - - - 01-08

German - - - - - 09-16

French - - - - - 17-24

Components

01 Backrest (x1)

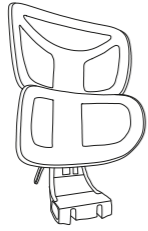

02 Seat (x1)

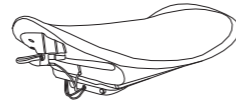

03 Armrest (x2)

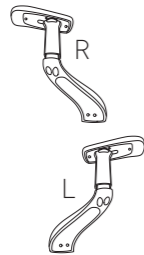

04 Cylinder (x1)

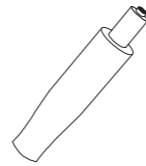

05 Base (x1)

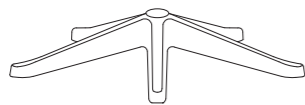

06 Casters (x5)



07 Headrest (x1)



08 Footrest (x1)

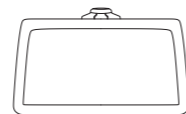

A x2+1 (M6x16MM)



B x4+1 (M8x45MM)



C x3+1 (M8x60MM)



D x3+1 (M8x17x1.5MM)



E x4+1 (M8x22x2.0T)



F x3+1 (M8)



G x1+1(M5x10MM)



T1 Allen Key x1



T2 Allen Key x1



Installation

The installation steps are as follows:

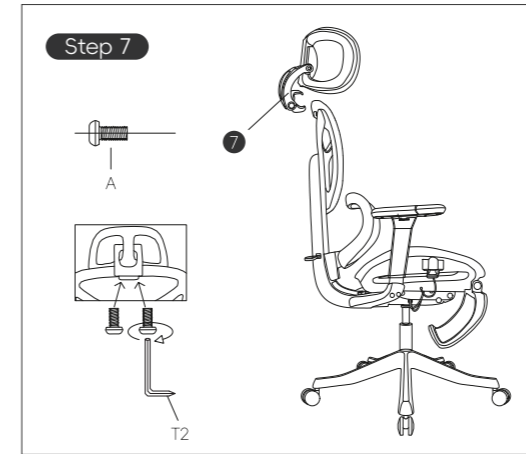
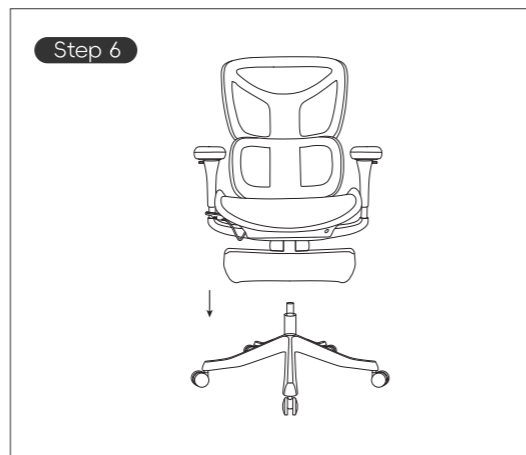
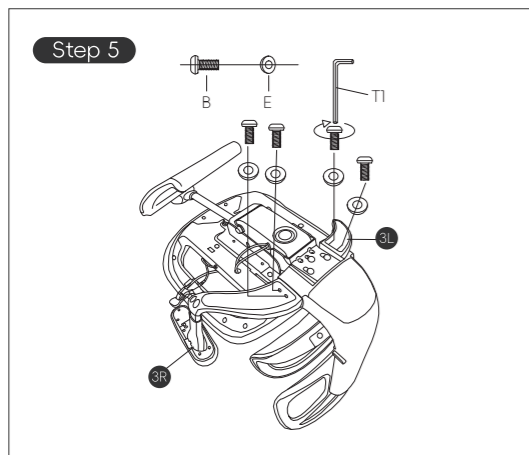
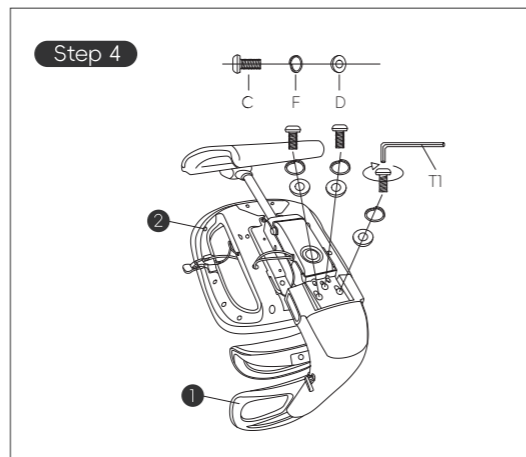
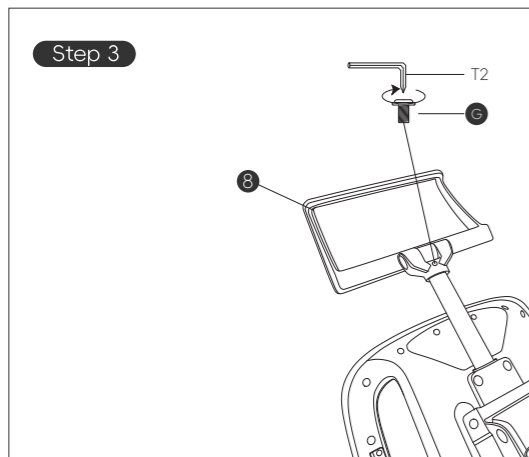
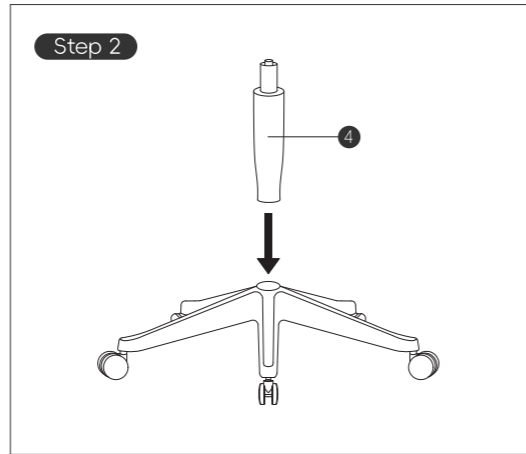
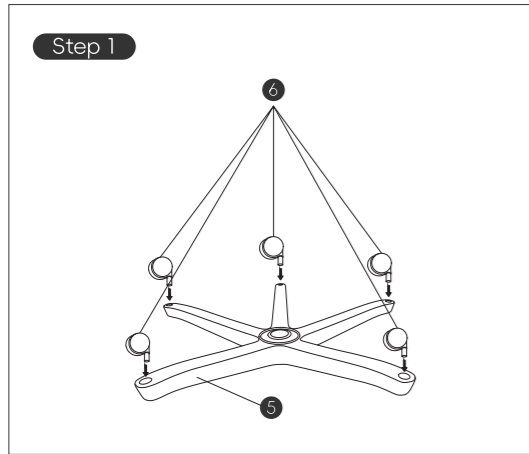

All Done!

Go ahead, try it out. You may experience what we call an "ahhh" sensation. That's completely normal. You're now well equipped for whatever the workday throws at you.

Now, don't be shy. Show us how us how it looks!

User Guide

01

Pull the pedals forward, press the button to rotate, and rotate the pedals to open the pedals.

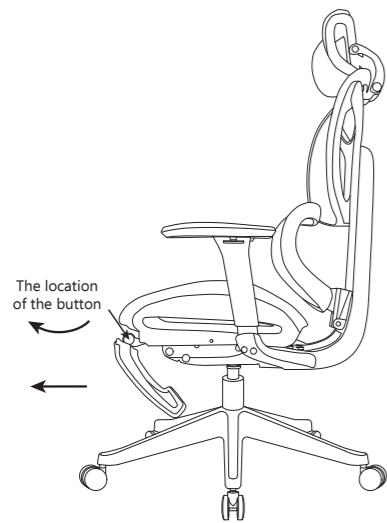

02

Hold the button down, turn the pedal down and push it back to retract the pedal.

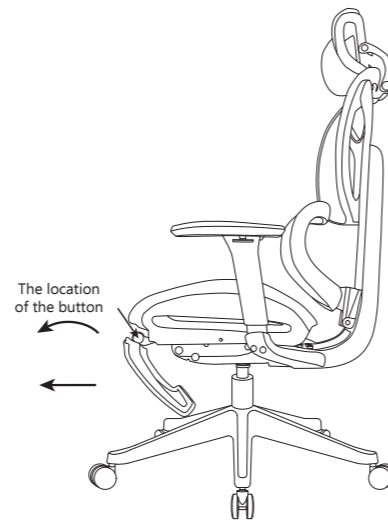

03

The lumbar adjusts slightly in height and depth. A is locked in position. B is the unlocked position.

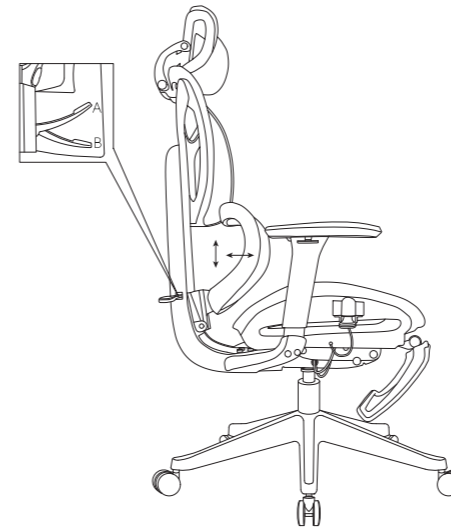

04

The backrest can be adjusted up and down with 5 height levels for support.

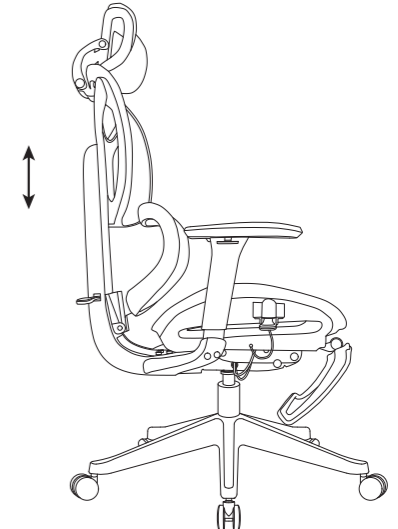

Caution

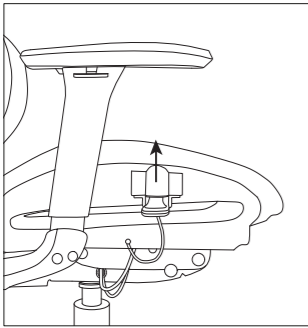

The handle can be raised to adjust the height of the seat.

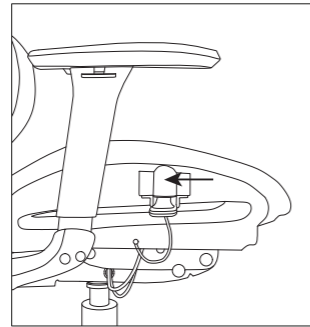

Move the handle backwards to adjust the tilt angle of the backrest.

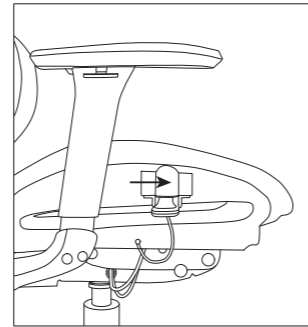

Move the handle forwards to adjust the seat front and back movement.

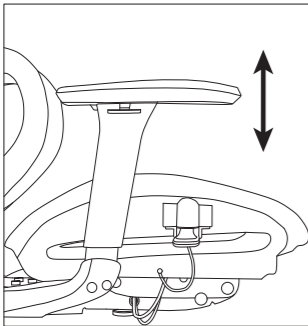

The armrest can be adjusted up and down.

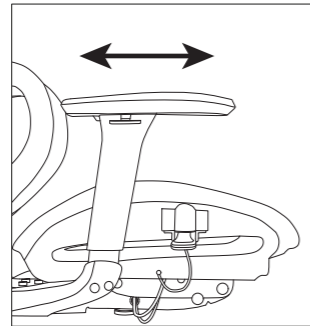

Move the armrest back and forth.

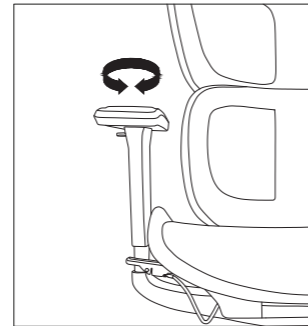

Adjust the armrest rotation.

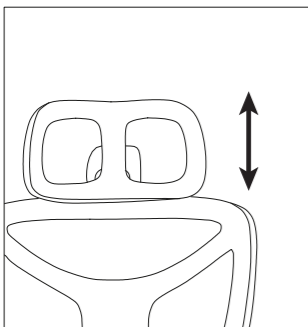

Adjust the headrest up and down.

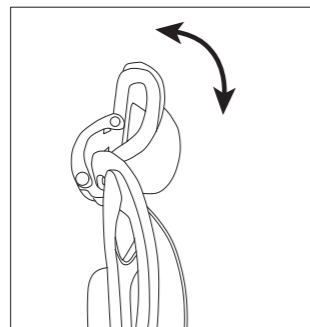

Adjustment headrest rotation.

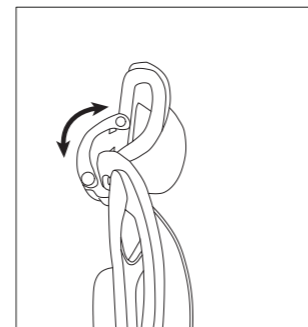

The headrest bracket can be rotated and adjusted.

- Use this product only for seating one person at a time.
- Some screws may be preassembled. If preassembled, ignore assembly instructions.
- Handle cylinders and mechanical components with care. They may contain grease that could stain chair surfaces or clothing if contacted.
- Do not use this chair as a step stool/ladder, or on uneven floor surfaces.
- Do not sit on any part of the chair except the seat.
- Do not use chair unless all bolts, screws, and knobs are tightened.
- Every six months, ensure all bolts, screws, and knobs are fully tightened to maintain stability.
- If any components are missing, damaged, deformed, or worn, discontinue use and repair only with manufacturer-authorized parts.
- Failure to follow these warnings could result in serious injury.

Components

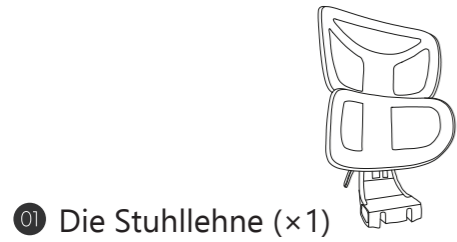

01 Die Stuhllehne (x1)

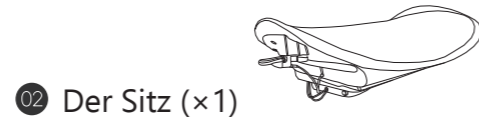

02 Der Sitz (x1)

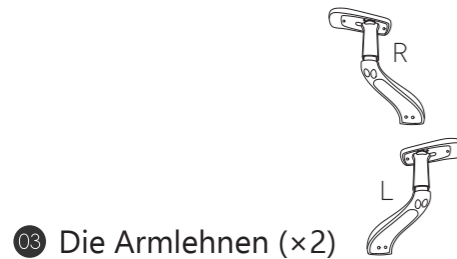

03 Die Armlehnen (x2)

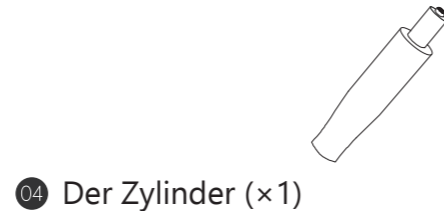

04 Der Zylinder (x1)

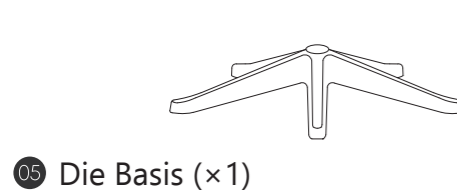

05 Die Basis (x1)



06 Die Rollen (x5)



07 Die Kopflehne (x1)

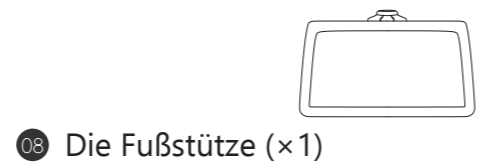

08 Die Fußstütze (x1)

A x2+1 (M6x16MM)



B x4+1 (M8x45MM)



C x3+1 (M8x60MM)



D x3+1 (M8x17x1.5MM)



E x4+1 (M8x22x2.0T)



F x3+1 (M8)



G x1+1 (M5x10MM)



T1 Inbusschlüssel x1



T2 Inbusschlüssel x1

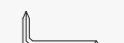

Montageanleitung

Die Installation läuft wie folgt ab:

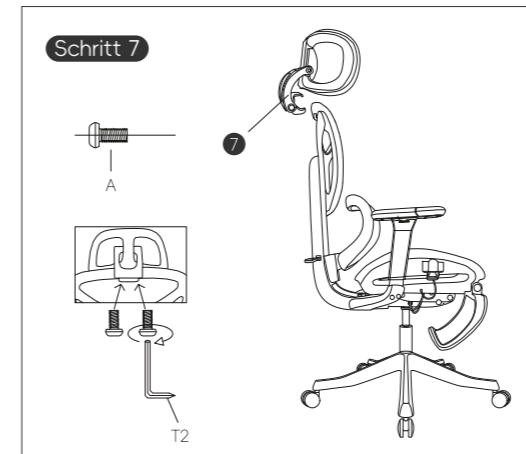
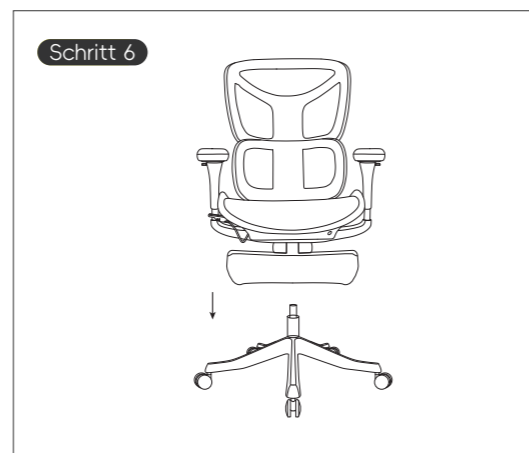
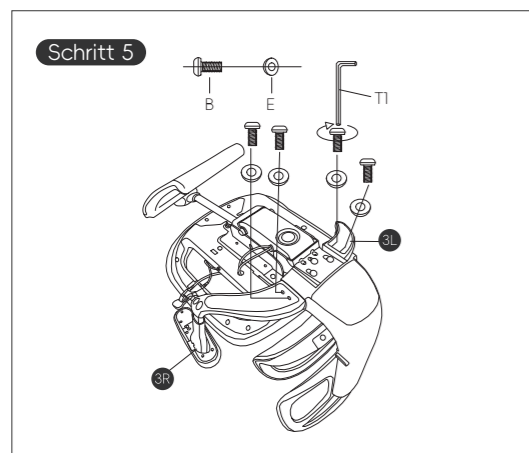
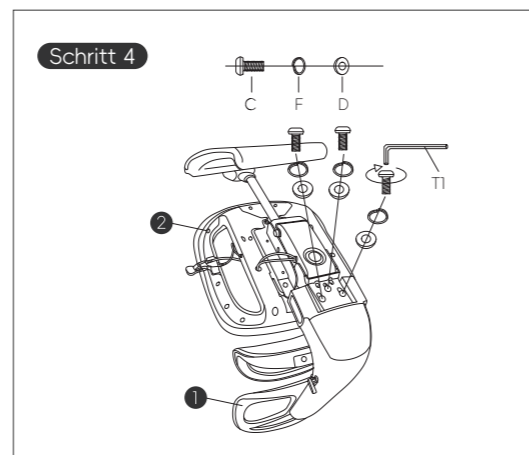
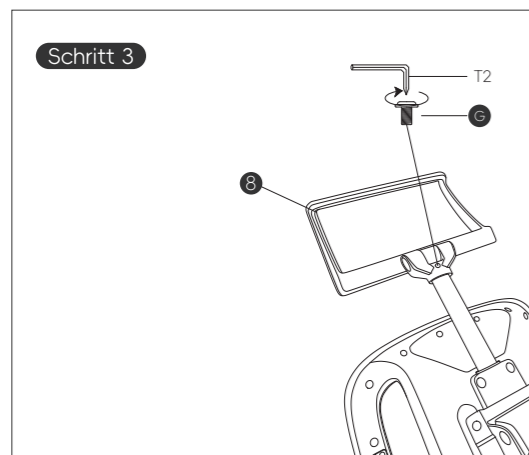
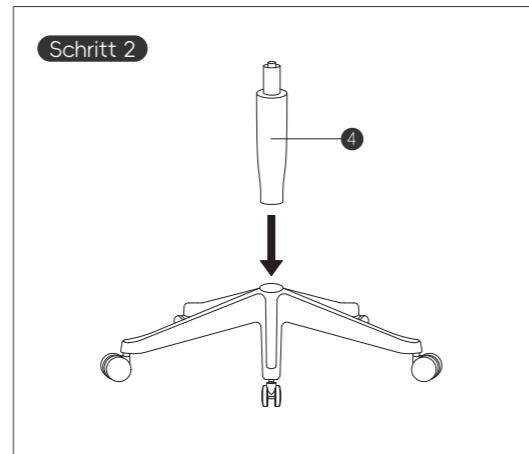
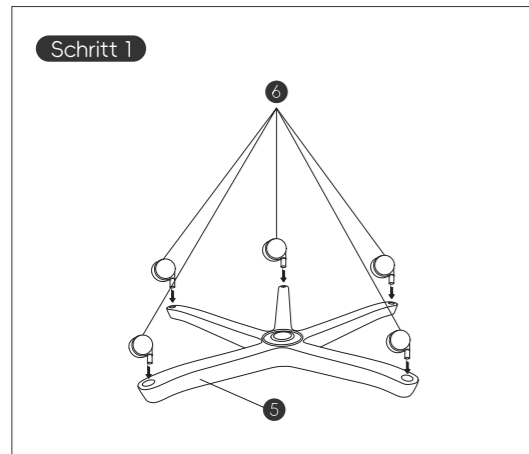

Geschafft!

Probieren Sie es aus, Sie werden vielleicht ein „ahhh“ - Gefühl verspüren.

Das ist völlig normal. Sie sind jetzt gut gerüstet für alles, was der Arbeitstag Ihnen abverlangt.

Seien Sie nicht schüchtern, lassen Sie uns sehen, wie es aussieht!

Benutzerhandbuch

01

Pedal nach vorn ziehen, Knopf drücken und gegen den Uhrzeigersinn drehen, um es zu öffnen.

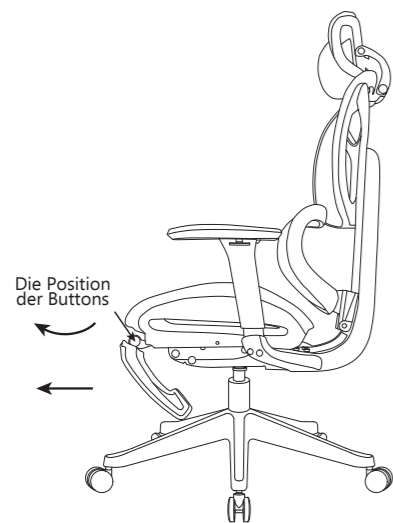

02

Knopf gedrückt halten, Pedal nach unten treten und nach hinten schieben, um es einzuziehen.

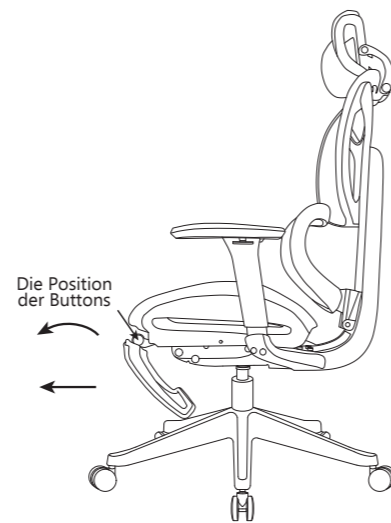

03

Die Lordosenstütze kann in Höhe und Winkel verstellt werden. A verriegelte, B entriegelte.

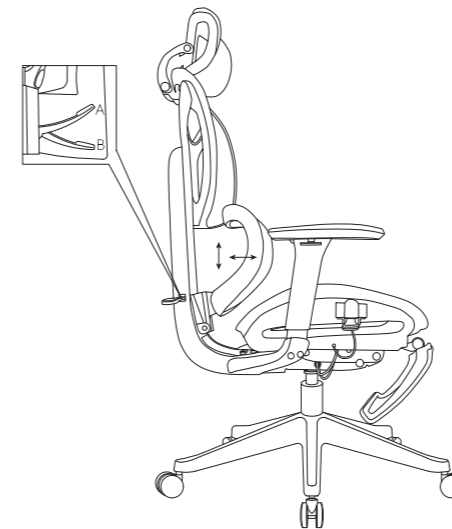

04

Die Rückenlehne kann in fünf Stufen nach oben und unten verstellt werden.

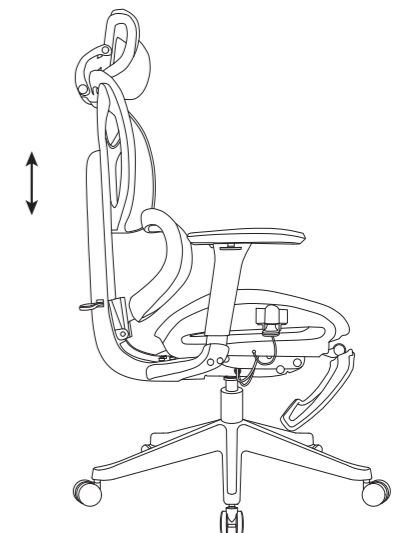

Achtung

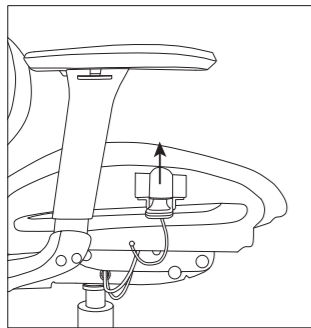

Griff anheben zur Einstellung der Sitzhöhe.

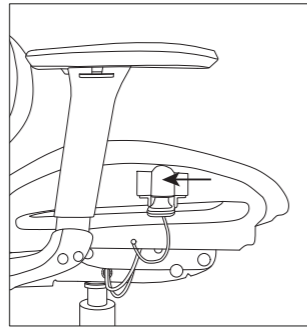

Griff nach hinten ziehen zum Arretieren der Rückenlehne.

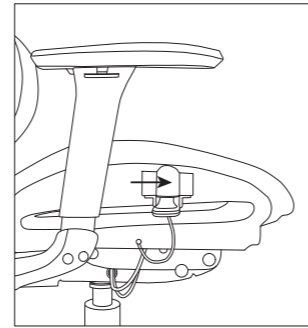

Griff nach vorn bewegen zum Verschieben des Sitzes.

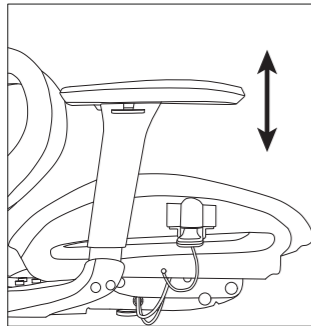

Die Armlehne kann nach oben und unten verstellt

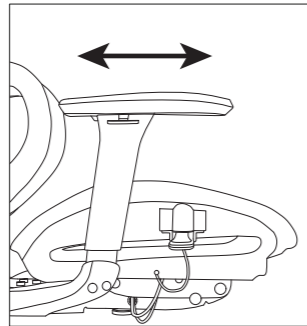

Bewegen Sie die Armlehne vor und zurück.

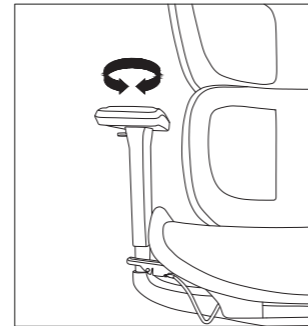

Einstellen der Drehung der Armlehne.

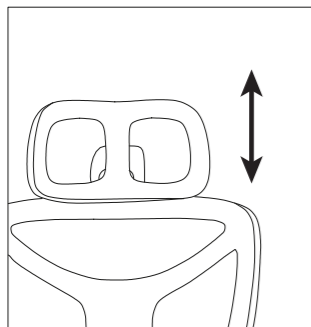

Verstellen der Kopflehne nach oben und unten.

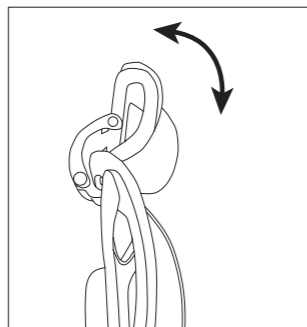

Kopfstützenverstellung und Drehung.

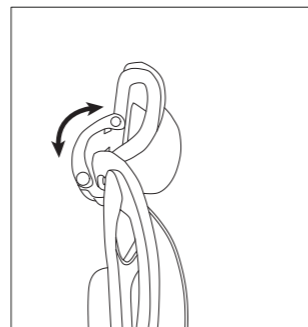

Kopfstützenhalter verstell- und drehbar.

- Verwenden Sie dieses Produkt nur für die Benutzung durch jeweils eine Person.
- Einige Schrauben können vormontiert sein. Wenn sie vormontiert sind, ignorieren Sie die Montageanleitung.
- Sie können Schmierfett enthalten, die bei Kontakt mit der Stuhloberfläche oder der Kleidung Flecken verursachen kann.
- Verwenden Sie den Stuhl nicht als Tritthocker/Leiter oder auf unebenen Böden.
- Setzen Sie sich auf keinen Teil des Stuhls außer auf den Sitz.
- Benutzen Sie den Stuhl nicht, wenn nicht alle Bolzen, Schrauben und Knöpfe fest angezogen sind.
- Stellen Sie alle sechs Monate sicher, dass alle Bolzen, Schrauben und Knöpfe fest angezogen sind, um die Stabilität zu gewährleisten.
- Wenn Teile fehlen, beschädigt, verformt oder abgenutzt sind, verwenden Sie den Stuhl nicht mehr und reparieren Sie ihn nur mit vom Hersteller zugelassenen Teilen.
- Die Nichtbeachtung dieser Warnhinweise kann zu schweren Verletzungen führen.

Composants

01 Dossier (x1)

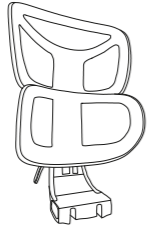

02 Siège (x1)

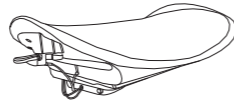

03 Accoudoirs (x2)

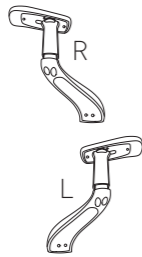

04 Cylindre (x1)

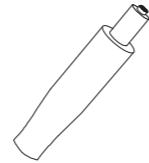

05 Base (x1)

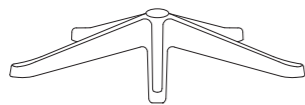

06 Roulettes (x5)



07 Appuie-tête (x1)



08 repose-pieds (x1)

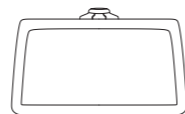

A x2+1 (M6x16MM)



B x4+1 (M8x45MM)



C x3+1 (M8x60MM)



D x3+1 (M8x17x1.5MM)



E x4+1 (M8x22x2.0T)



F x3+1 (M8)



G x1+1 (M5x10MM)

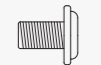

T1 Clé Allen x1



T2 Clé Allen x1



Installation

Les étapes d'installation sont les suivantes:

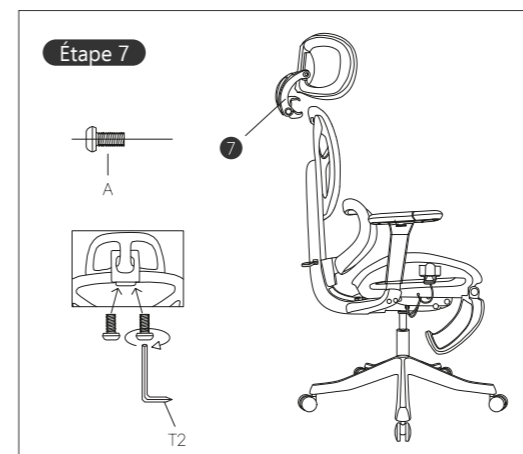
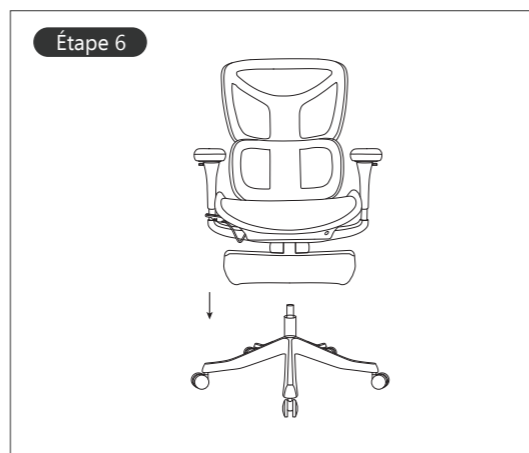
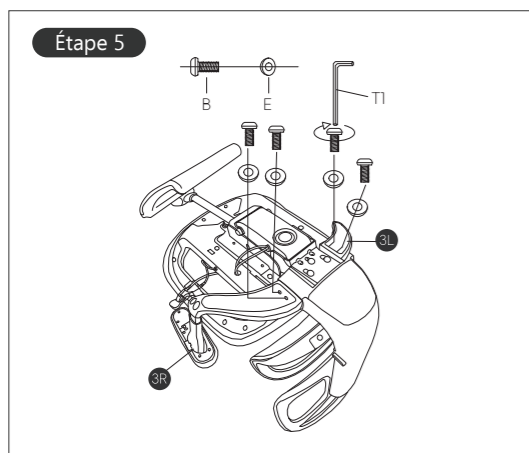
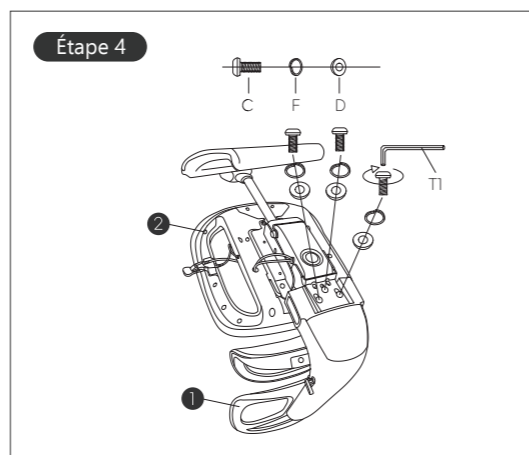
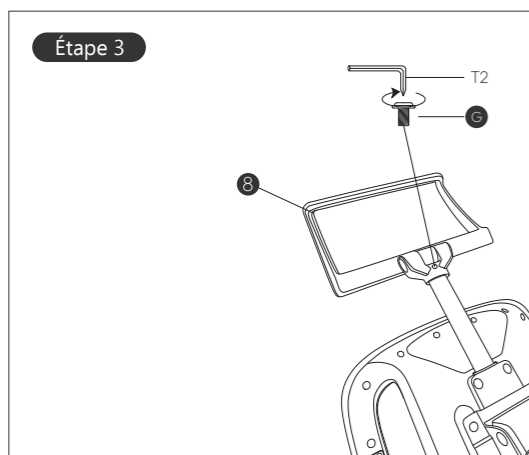
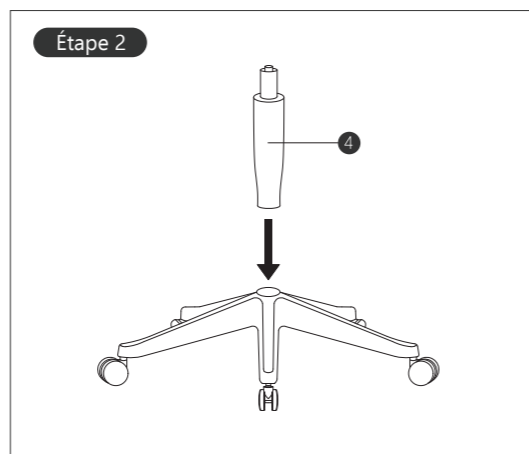
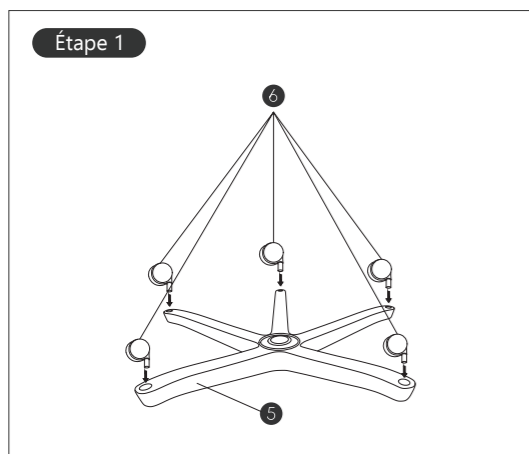

C'est terminé!

Allez-y, essayez-le. Vous pourriez ressentir ce que nous appelons une sensation d'"ahhh".

C'est tout à fait normal. Vous êtes maintenant parfaitement équipé pour affronter n'importe quoi que la journée de travail puisse vous proposer.

Maintenant, n'ayez pas peur. Montrez-nous comment ça Looks !

Guide d'utilisation

01

Tirez les pédales vers l'avant, appuyez sur le bouton pour les faire pivoter, puis tournez-les pour les déployer.

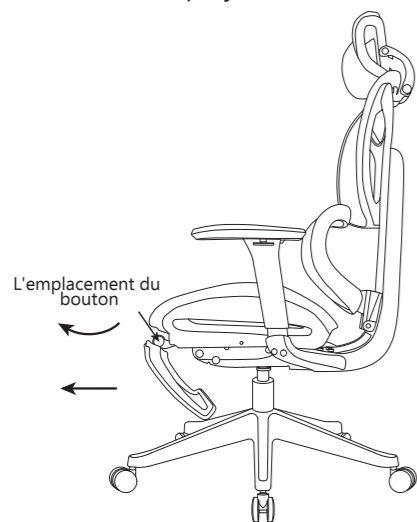

02

Maintenez le bouton enfoncé, abaissez la pédale et poussez-la vers l'arrière pour la rétracter.

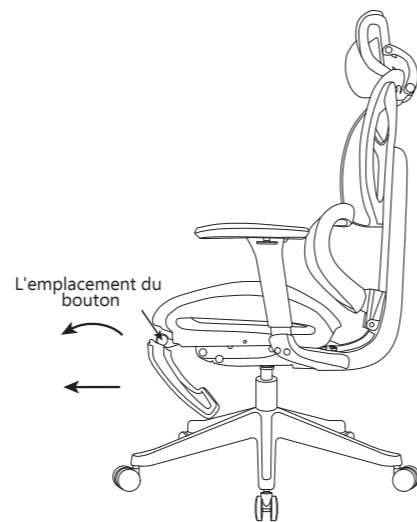

03

Le support lombaire bouge légèrement en hauteur et en profondeur. A verrouillé, B déverrouillé.

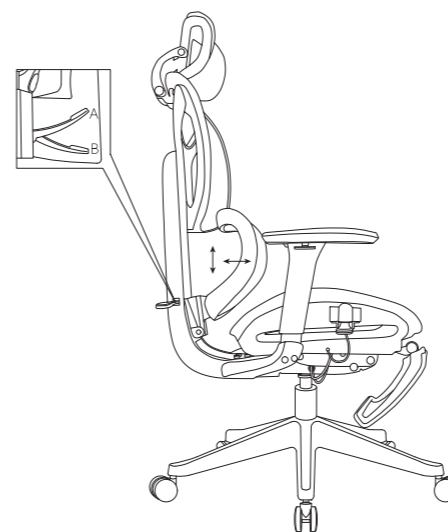

04

Le dossier est réglable en hauteur sur 5 niveaux pour un bon soutien.

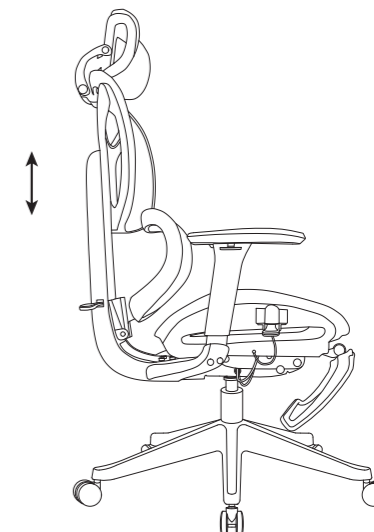

Attention

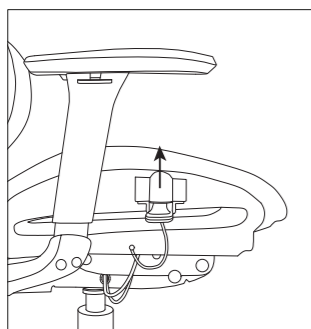

La poignée peut être soulevée pour ajuster la hauteur du siège.

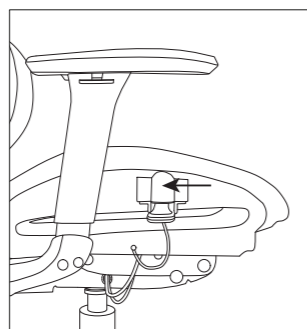

Déplacez la poignée vers l'arrière pour régler l'inclinaison du dossier.

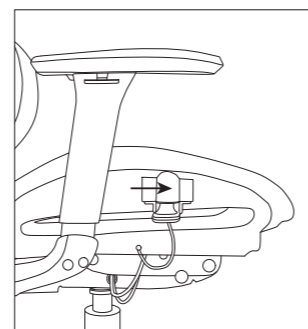

Avancez la poignée pour régler le déplacement avant/arrière du siège.

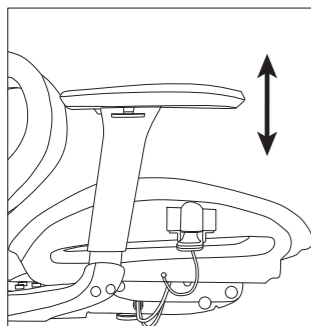

Les accoudoirs peuvent être réglés en hauteur.

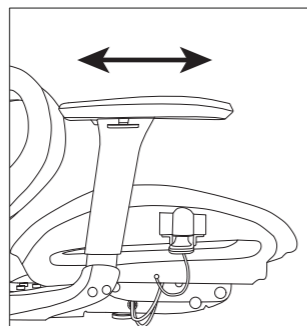

Réglage avant/arrière de l'accoudoir.

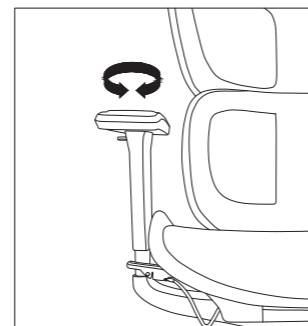

Ajustez la rotation des accoudoirs.

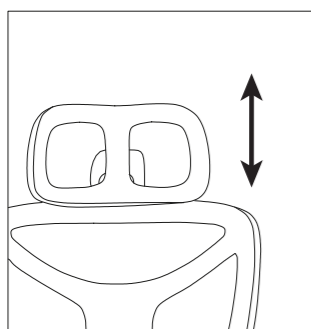

Ajustez l'appui-tête de haut en bas.

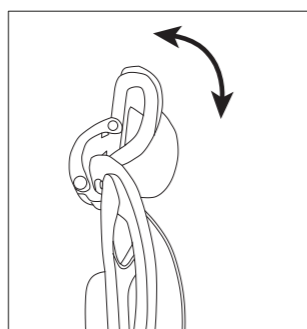

Réglage de l'appui-tête et rotation.

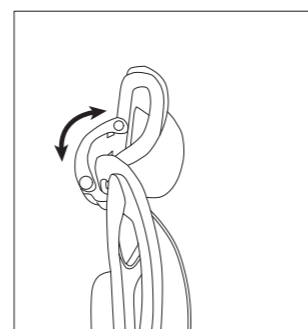

Support d'appui-tête réglable et pivotant.

- Utilisez ce produit uniquement pour assiéger une personne à la fois.
- Certains vis peuvent être préassemblés. En cas de préassemblage, ignorez les instructions d'assemblage.
- Manipulez avec soin les cylindres et les composants mécaniques. Ils peuvent contenir de la graisse qui pourrait tacher les surfaces de la chaise ou le vêtement en cas de contact.
- Ne pas utiliser cette chaise en tant que tabouret/échelle, ou sur des surfaces de sol inégales.
- Ne pas s'asseoir sur toute partie de la chaise autre que le siège.
- Ne pas utiliser la chaise si tous les boulons, vis et boutons ne sont pas serrés.
- Tous les six mois, assurez-vous que tous les boulons, vis et boutons sont entièrement serrés pour maintenir la stabilité.
- Si des composants manquent, sont endommagés, déformés ou usés, arrêtez l'utilisation et ne les réparez que avec des pièces autorisées par le fabricant.
- Le non-respect de ces avertissements pourrait entraîner de graves blessures.