

# Assembly Instructions

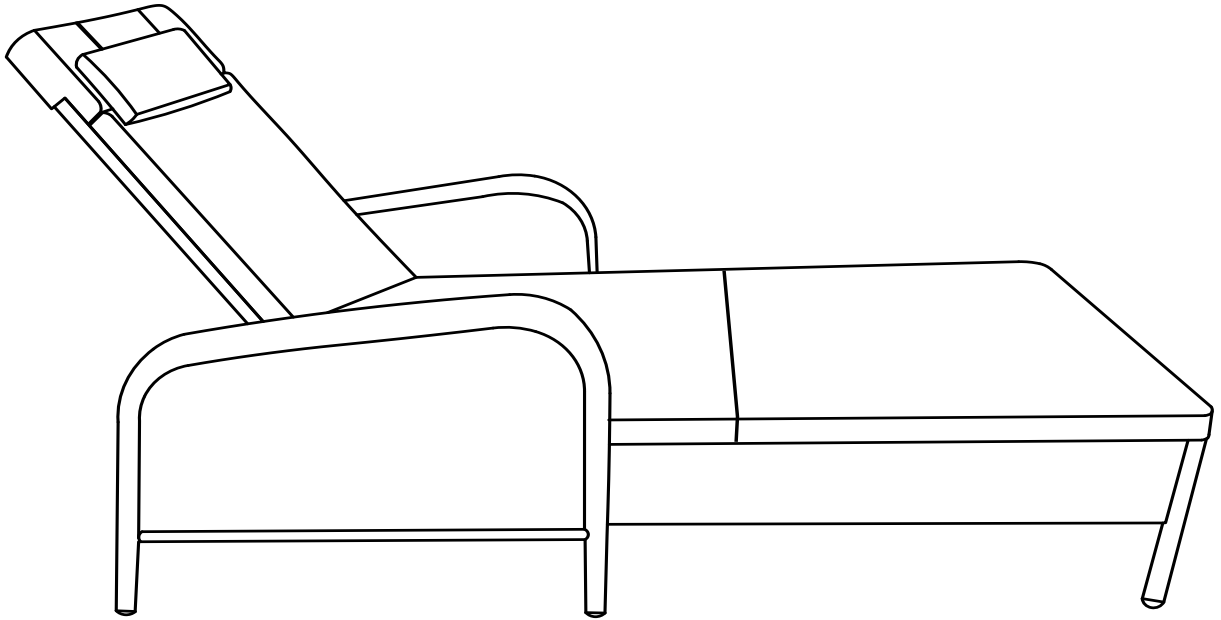







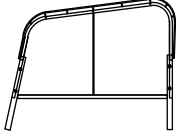

For any missing hardware, damaged parts and other problems.

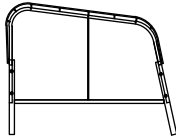
**\*Don't fully tighten all the bolts till the very end!**

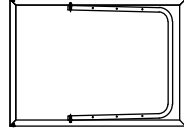
## PRE-ASSEMBLY PREPARATION:

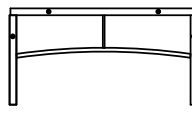
- Please read through the instructions before beginning assembly.
- Clear out the space for assembly and lay out all of the parts based on the Parts List, extra room will allow you to easily determine if all the pieces are present.
- Keep small parts and pieces away from children until fully assembled.

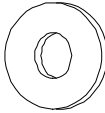
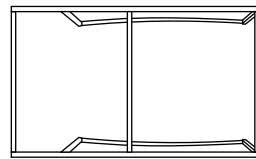
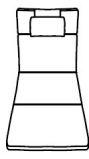
| Part no. | Part        | QTY | Image   | Part no. | Part              | QTY | Image   |
|----------|-------------|-----|---|----------|-------------------|-----|---|
| A1       | Left arm    | 1   |    | F        | Plastic gasket    | 2   |    |
| A2       | Right arm   | 1   |    | G        | Allen wrench      | 1   |    |
| B        | Back        | 1   |    | H        | Bolt<br>(M6*35mm) | 14  |    |
| C        | Front panel | 1   |    | I        | Bolt<br>(M6*40mm) | 2   |    |
| D        | Support     | 1   |   | J        | Washer            | 16  |    |
| E        | Seat        | 1   |  | K        | Cushion           | 1   |  |

**Step 1:** Attach back B to D with 2pcs bolts I, 2pcs washers J and 2pcs plastic gaskets F, using Allen wrench G.

Note: Part F is between part B and part D for protection and against friction.

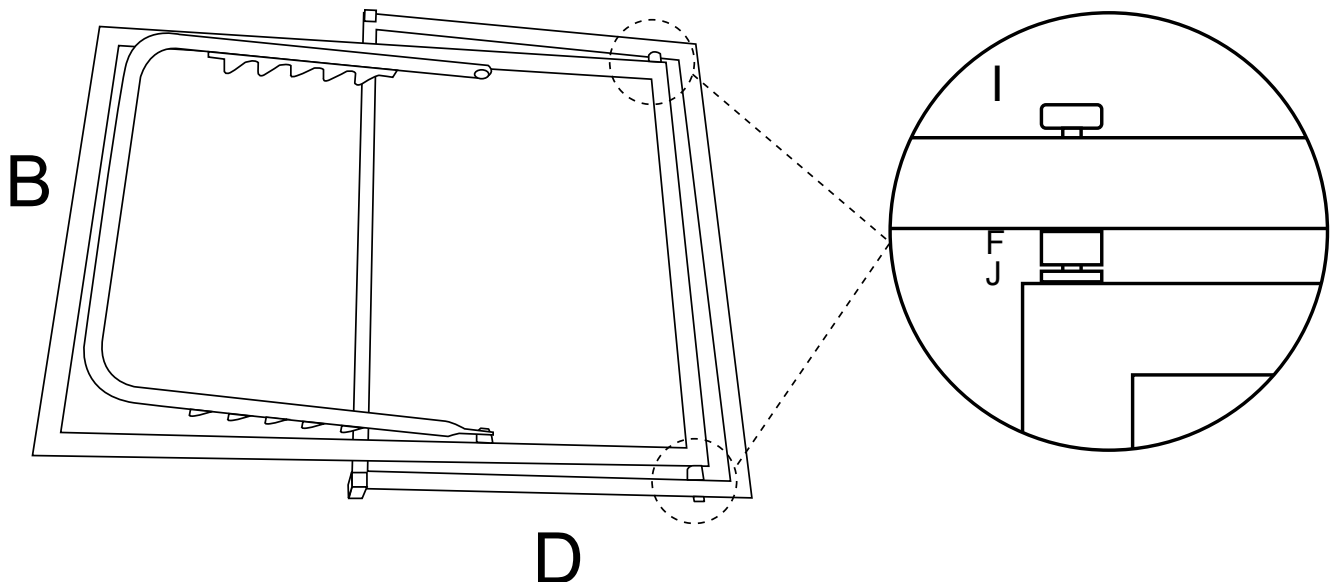

**Step 2:** Attach D to seat E with 2pcs bolts H and 2pcs washers J, using Allen wrench G.

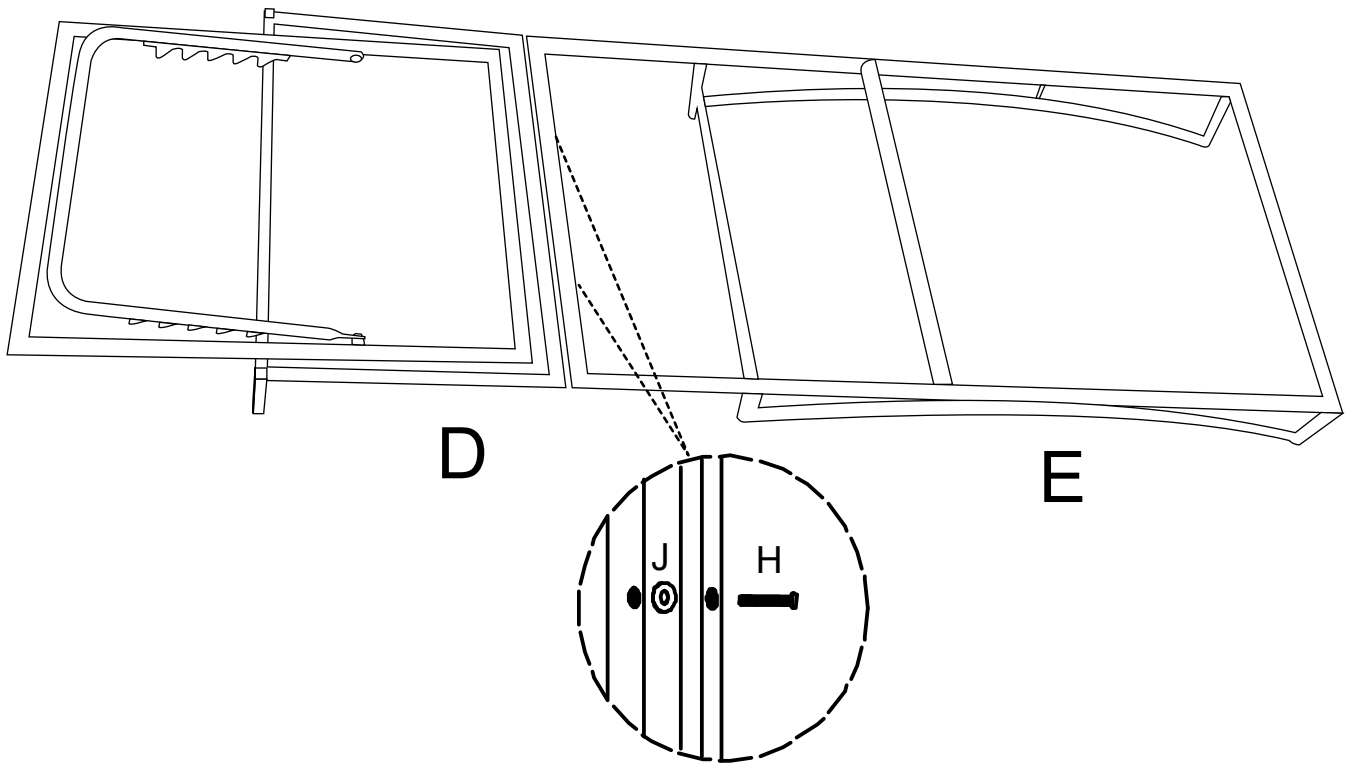

**Step 3:** Attach arm A1&A2 to seat E with 8pcs bolts H and 8pcs washers J, using Allen wrench G.

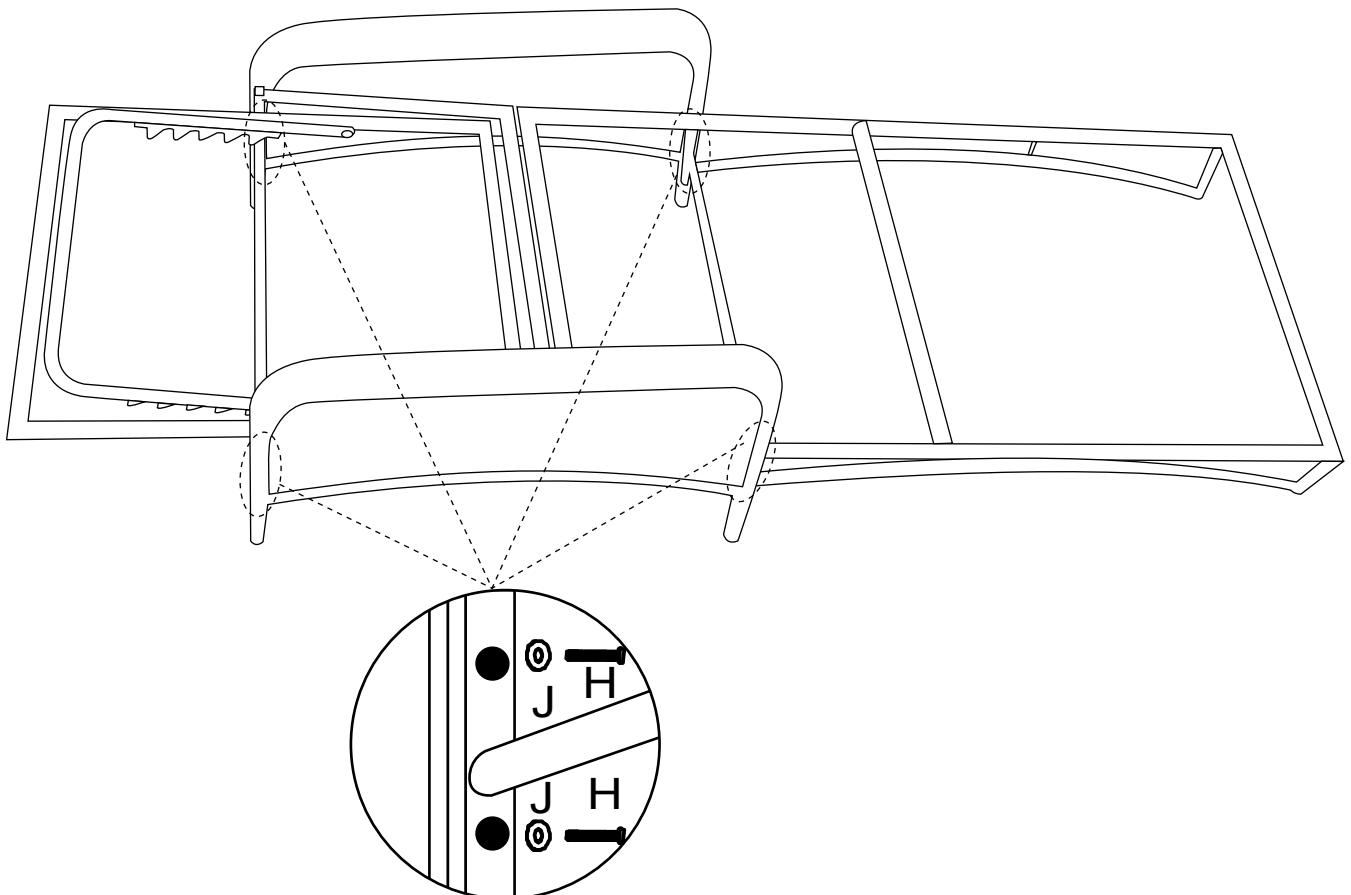

**Step 4:** Attach front panel C to seat E with 4pcs bolts H and 4pcs washers J, using Allen wrench G.



Bolt H x 4  
M6\*35mm



Washer J x 4

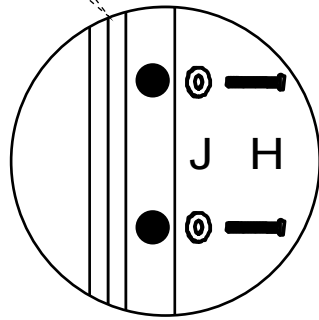
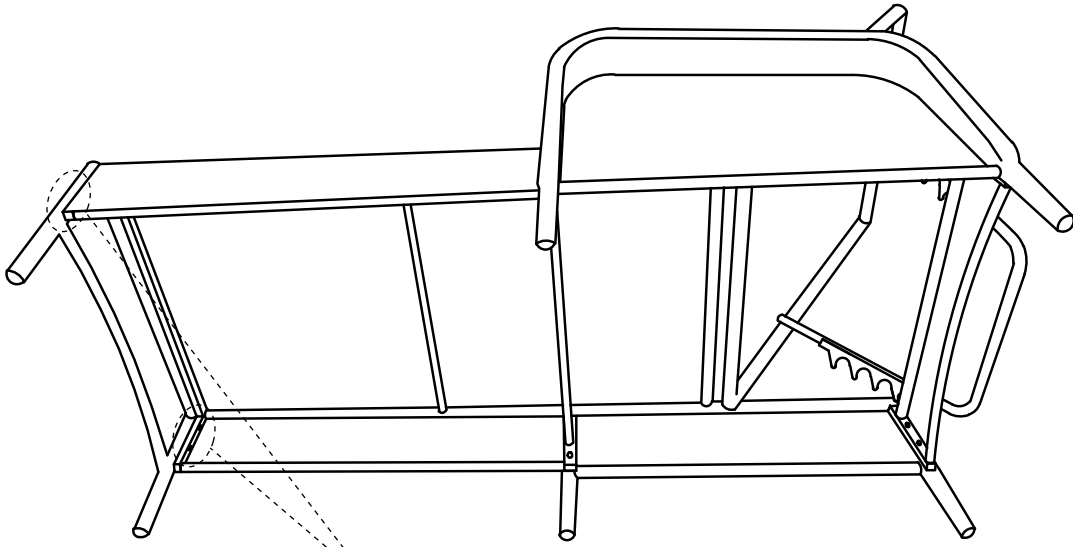

**Step 6:** Put cushion K onto the seat. Assembly is now complete and the product is ready for use.

