

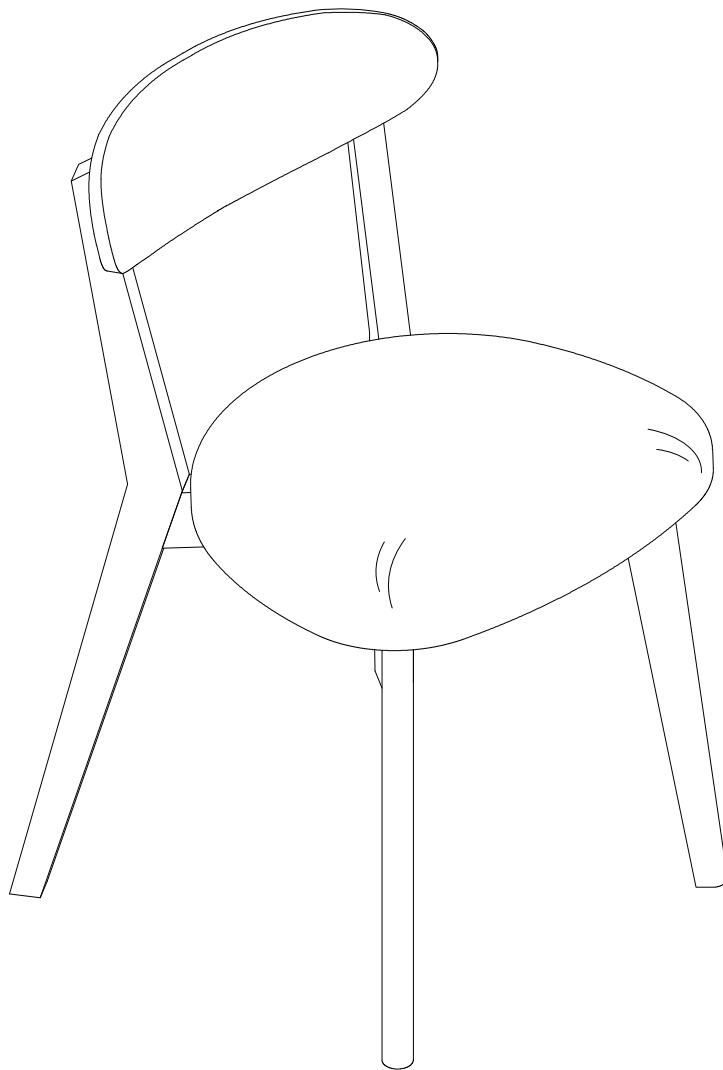

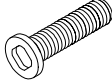

# Assembly Instructions

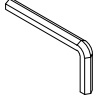

# Part List

<p>No. A Quantity: 8 Pcs Screw M6*45mm</p> 	<p>No. B Quantity: 24 Pcs Screw M6*30mm</p> 	<p>No. C Quantity: 8 Pcs Gasket Ø6*13mm</p> 	<p>No. D Quantity: 1 Pcs Allen Key 4#</p> 
<p>No. E Quantity: 8 Pcs Adjust The Foot</p> 			

**x2**

# Product structure

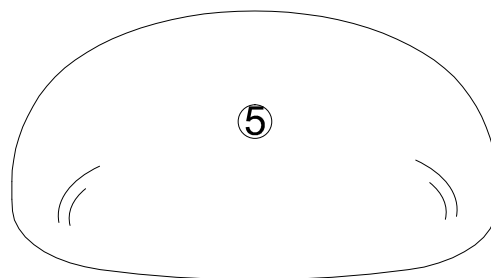
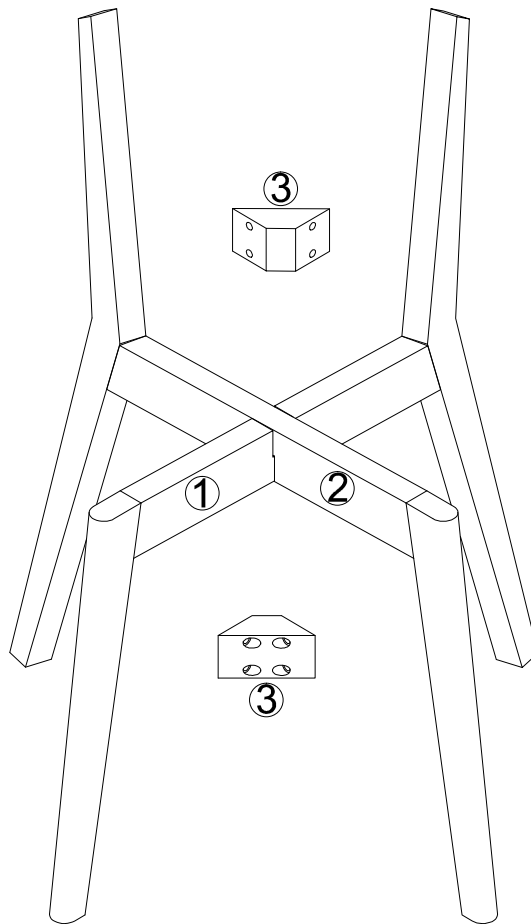
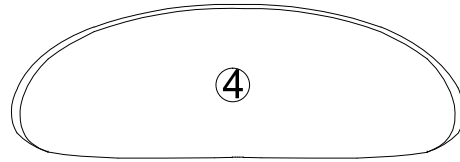

**x2**

# STEP 1

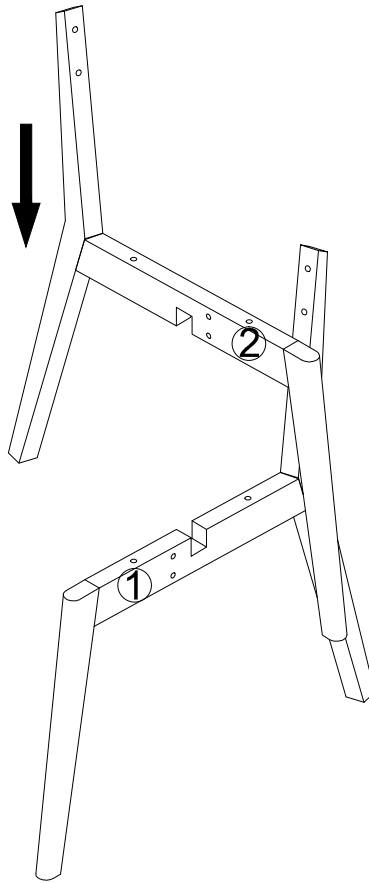

# STEP 2

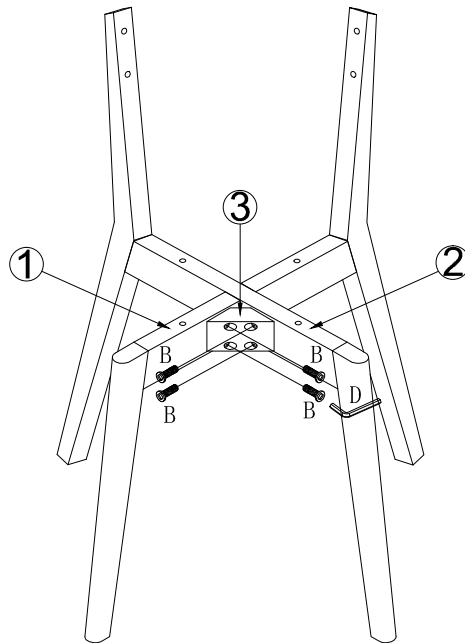

No. B  
Quantity: 4 Pcs  
M6\*30mm



No. D  
Quantity: 1 Pcs  
4#



# STEP 3

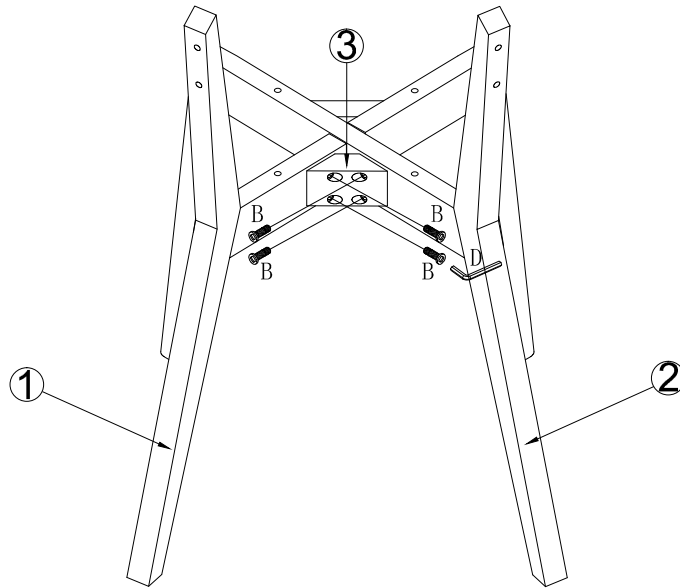

No. B  
Quantity: 4 Pcs  
M6\*30mm



No. D  
Quantity: 1 Pcs  
4#



# STEP 4

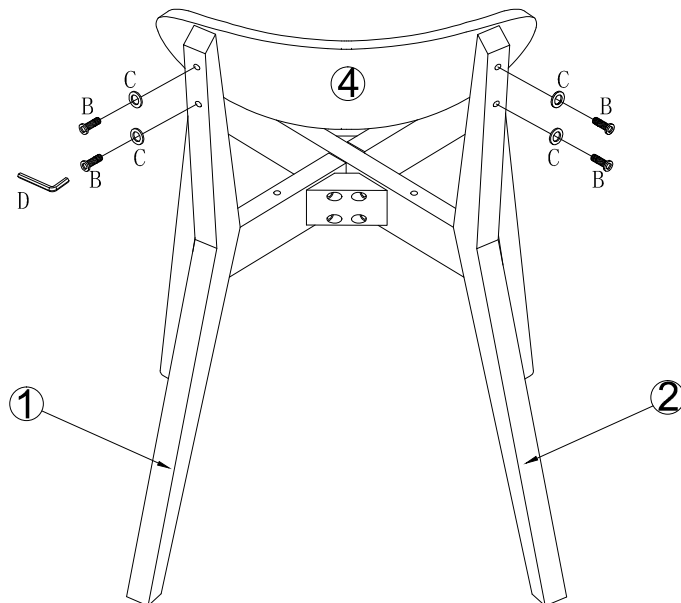

No. B  
Quantity: 4 Pcs  
M6\*30mm



No. C  
Quantity: 4 Pcs  
Ø6\*13mm



No. D  
Quantity: 1 Pcs  
4#



# STEP 5

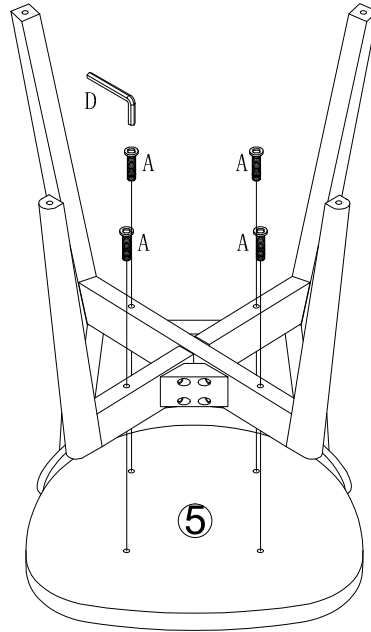

No. A  
Quantity: 4 Pcs  
M6\*45mm

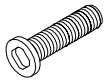

No. D  
Quantity: 1 Pcs  
4#



# STEP 6

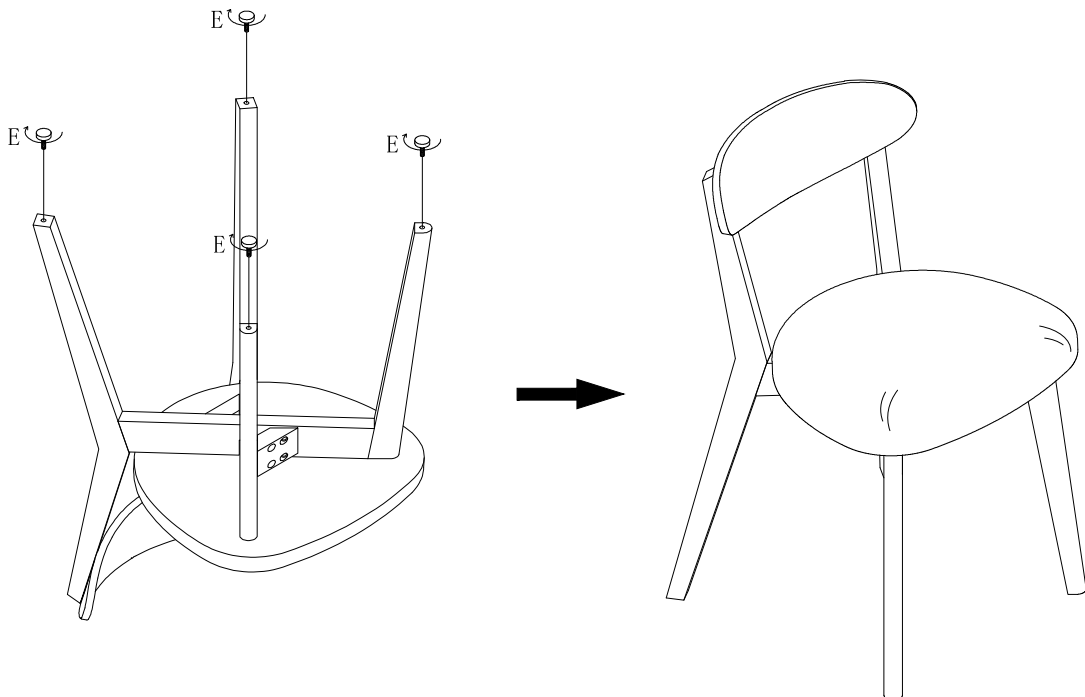

No. E  
Quantity: 4 Pcs

