

INSTRUCTIONS

Modular Sofa

CARTON A PART LIST

A Left Armrest

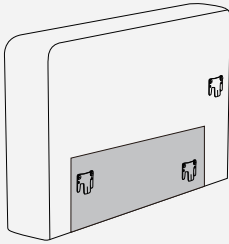

x1

B Right Armrest

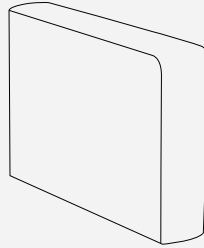

x1

1 Plastic Leg

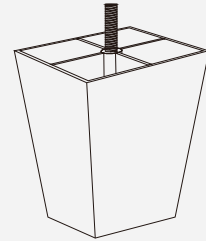

x4

2 Plastic Washer

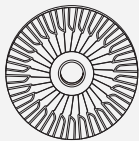

x4

CARTON B PART LIST

C Long Seat Frame

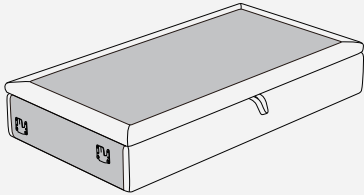

x1

D Long Back Frame

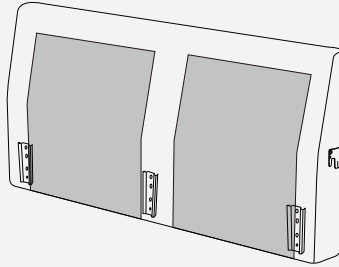

E Seat Cushion

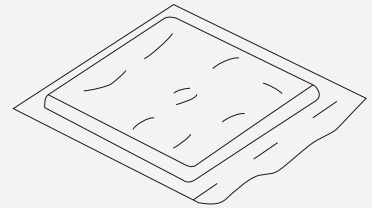

x2

F Back Pillow

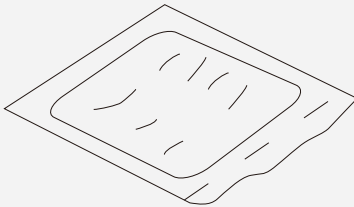

x2

1 Plastic Leg

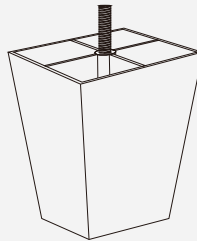

x4

2 Plastic Washer

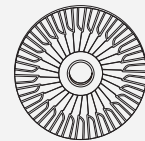

x4

CARTON B PART LIST

3 Assembly Instructions

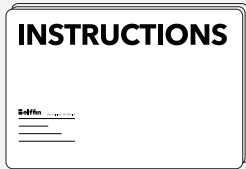

x1

CARTON C PART LIST

G Single Seat Frame

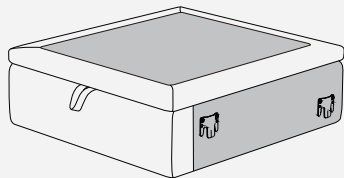

x1

H Single Back Frame

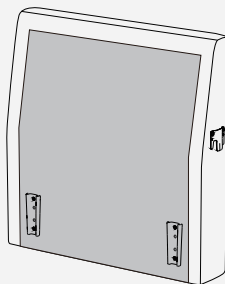

x1

E Seat Cushion

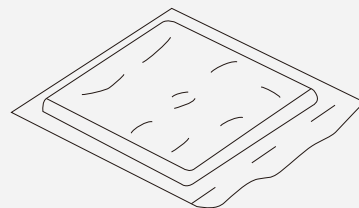

x1

F Back Pillow

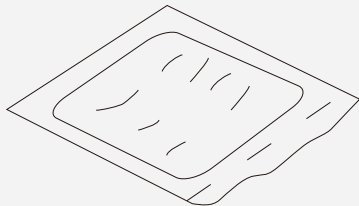

x1

1 Plastic Leg

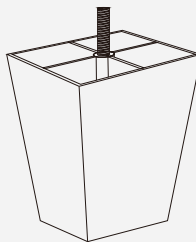

x4

2 Plastic Washer

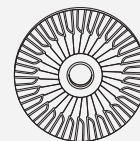

x4

CARTON D PART LIST

J Corner Seat Frame

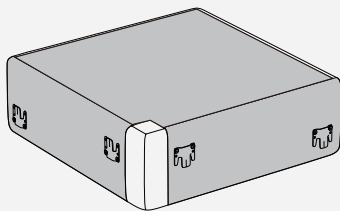

x1

K Corner Short Back Frame

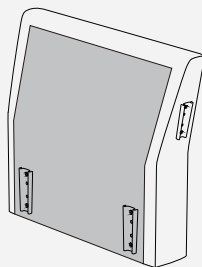

x1

L Corner Long Back Frame

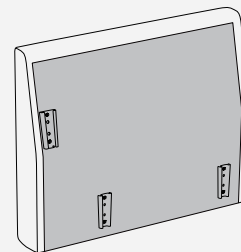

x1

M Corner Seat Cushion

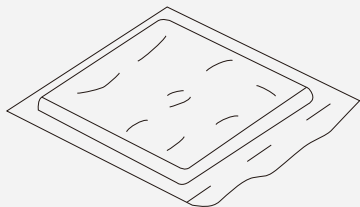

x1

N Long Corner Back Pillow

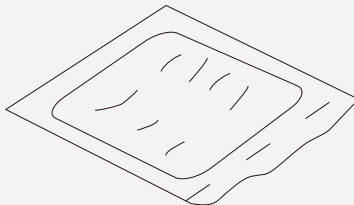

x1

P Small Corner Back Pillow

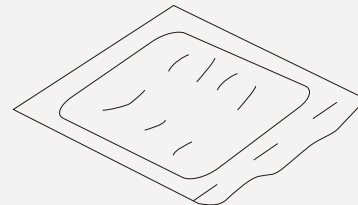

x1

ASSEMBLY

1. Please open all cartons and remove all parts from them carefully.
Place all parts on protected surface or carpet.
2. Please connect the right armrest (part B in the carton A) with the seat frame first, then connect the rest seat frames according to the assembly instructions.
3. Then please insert all the backrests into the seat frames, and connect the left armrest (part A in the carton A) finally with the seat frame according to the assembly instructions

Step1:

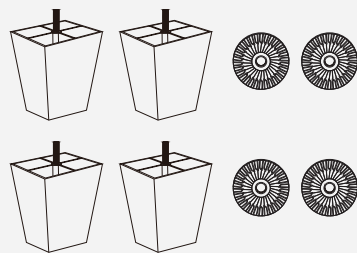
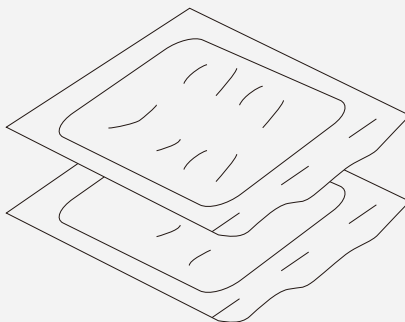
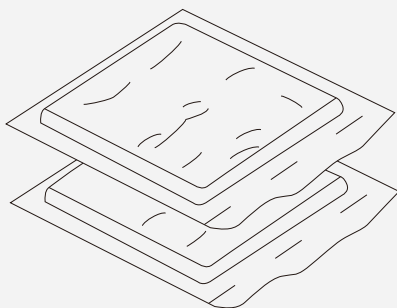
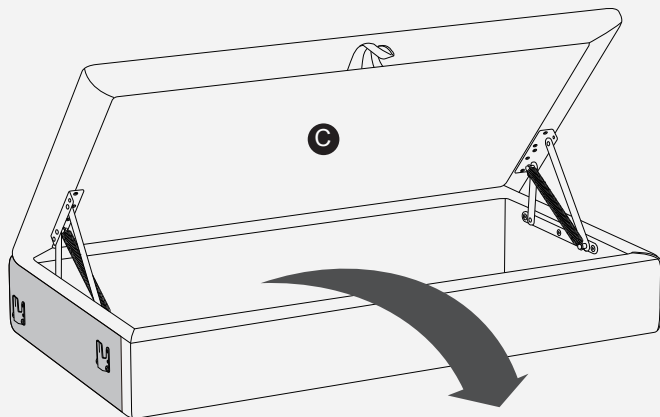

Step2:

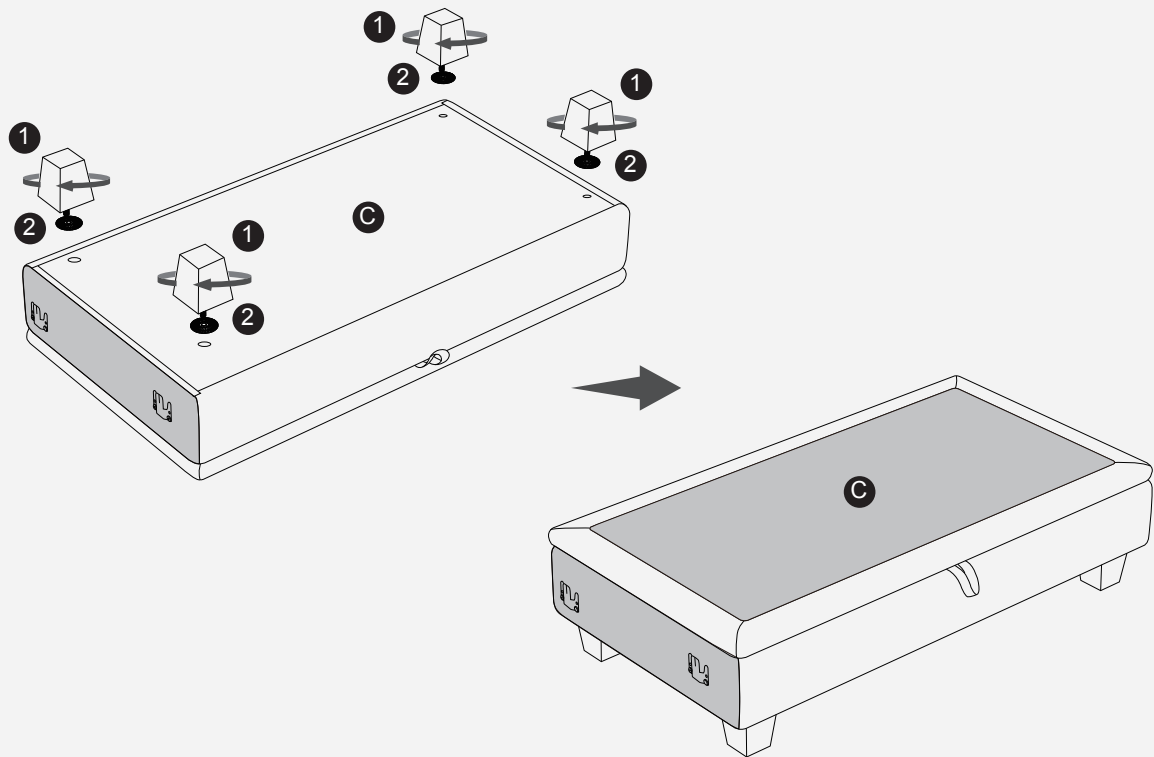

Step3:

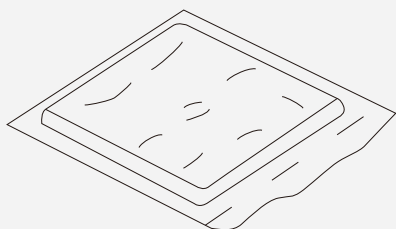
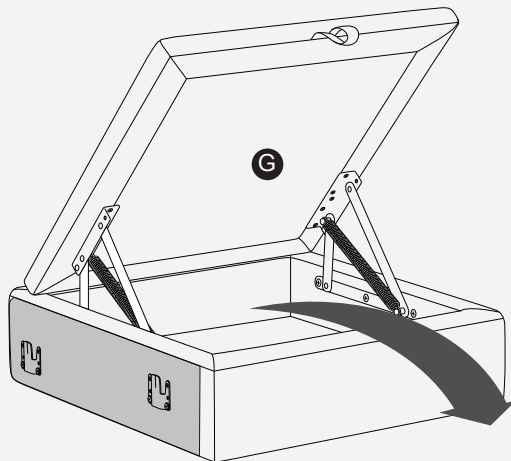

E

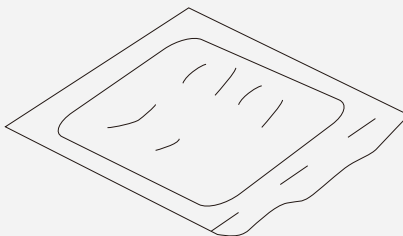

F

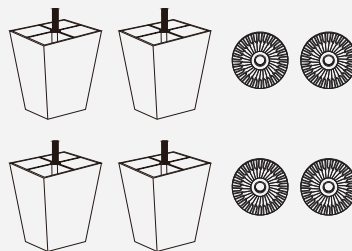

1

2

Step4:

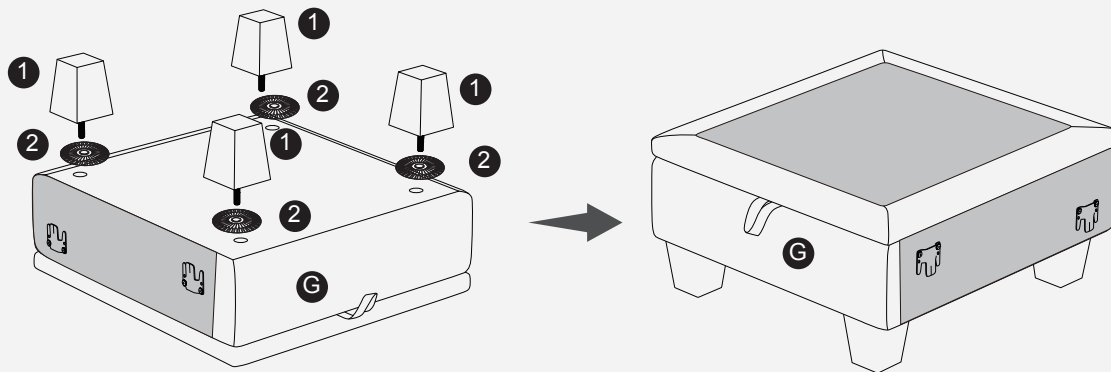

Step5:

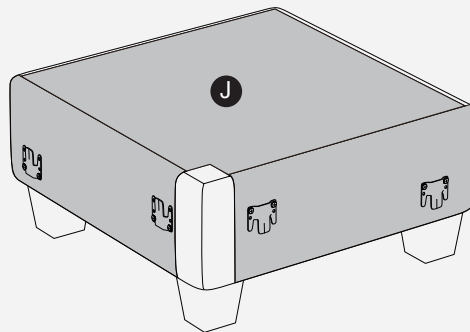
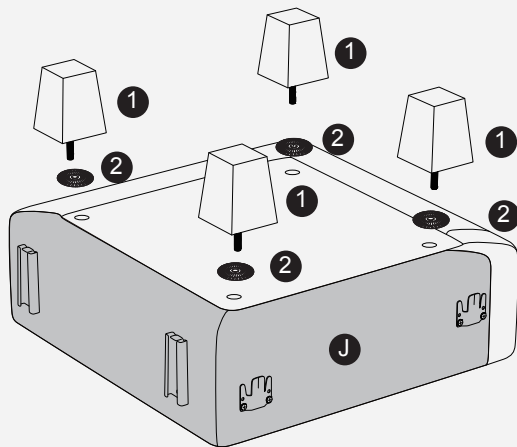

Step6:

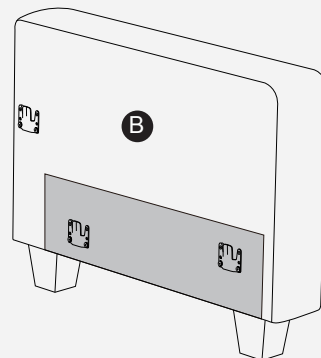
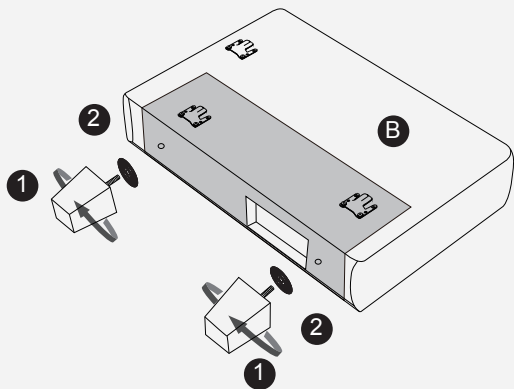
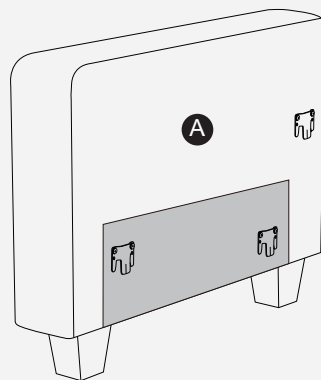
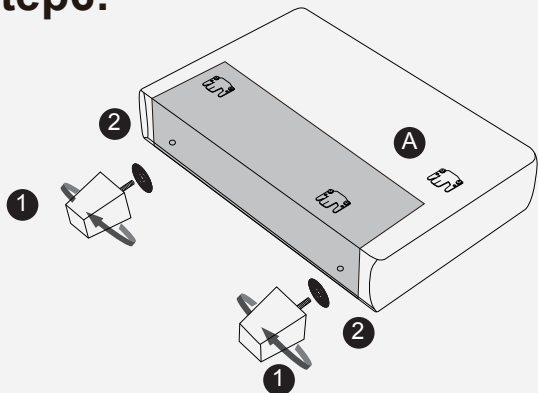

Step7:

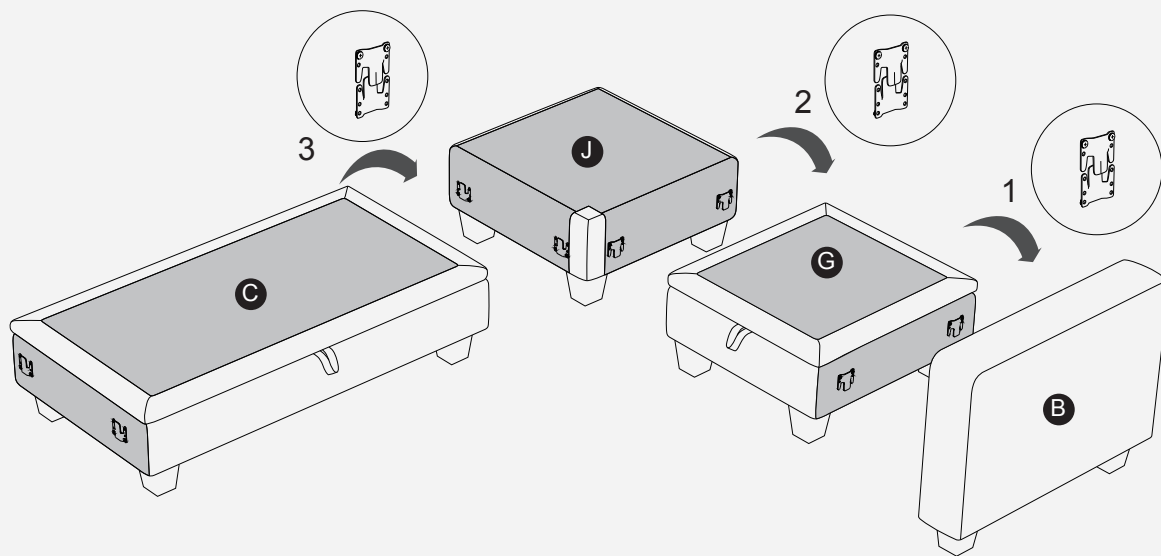

Step8:

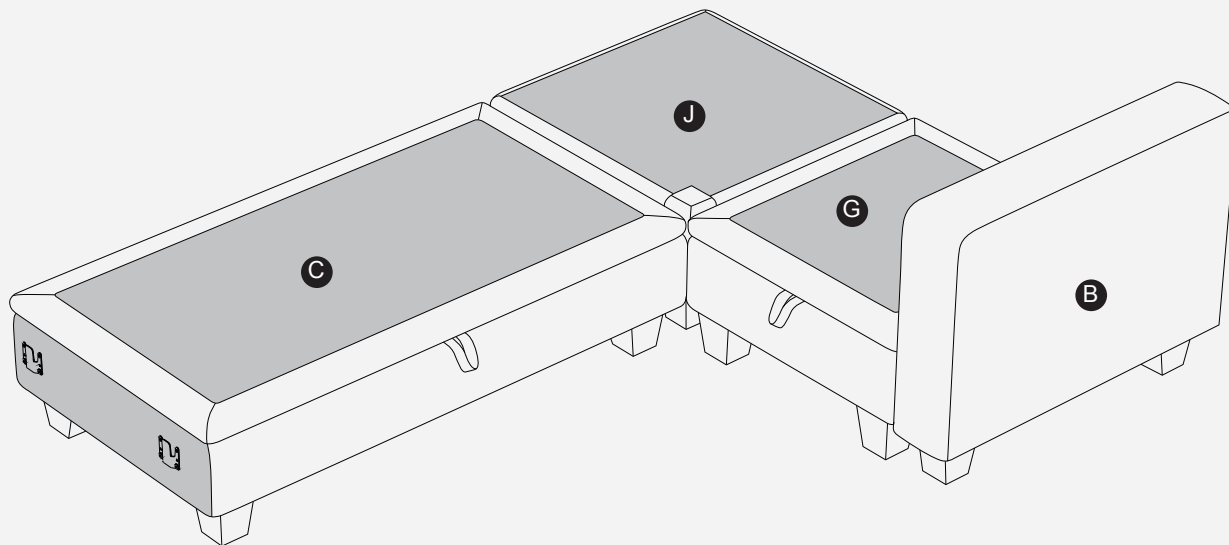

Step9:

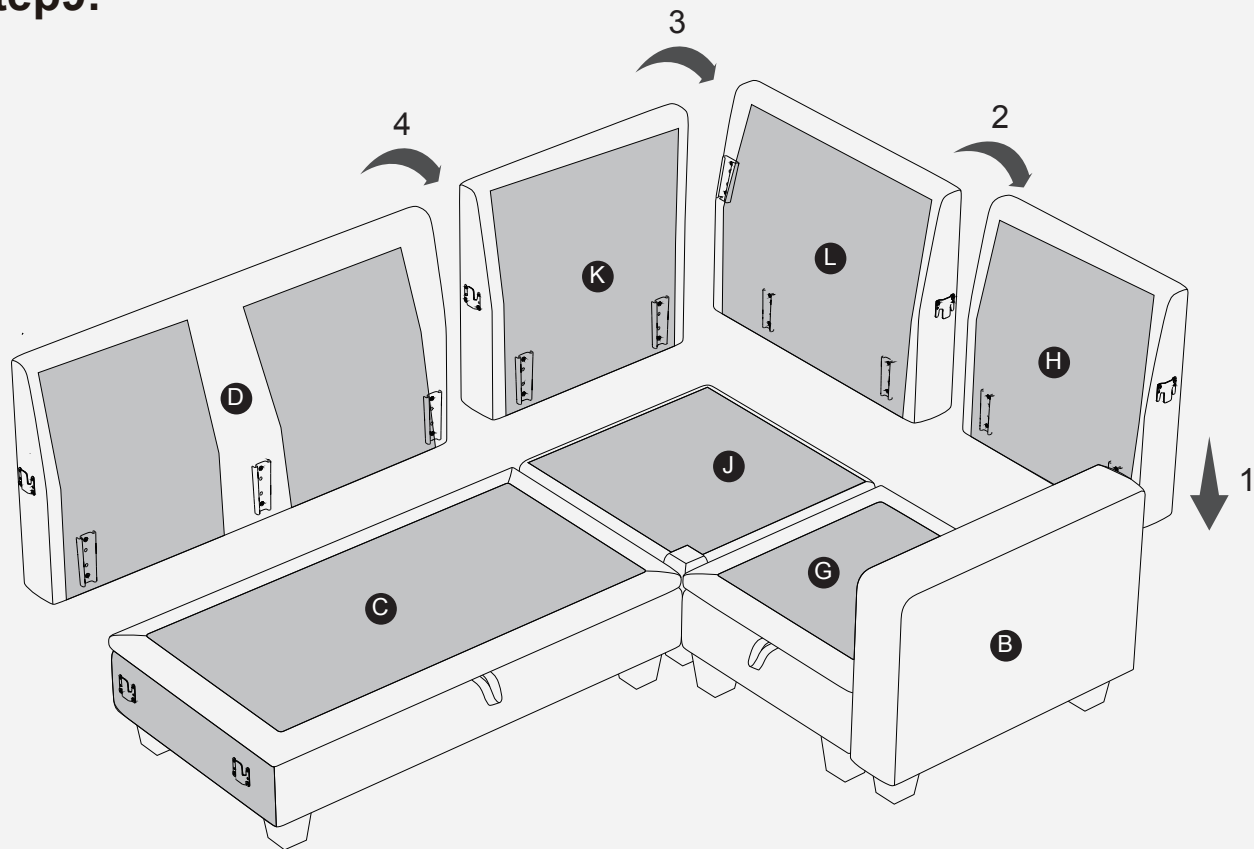

Step10:

C

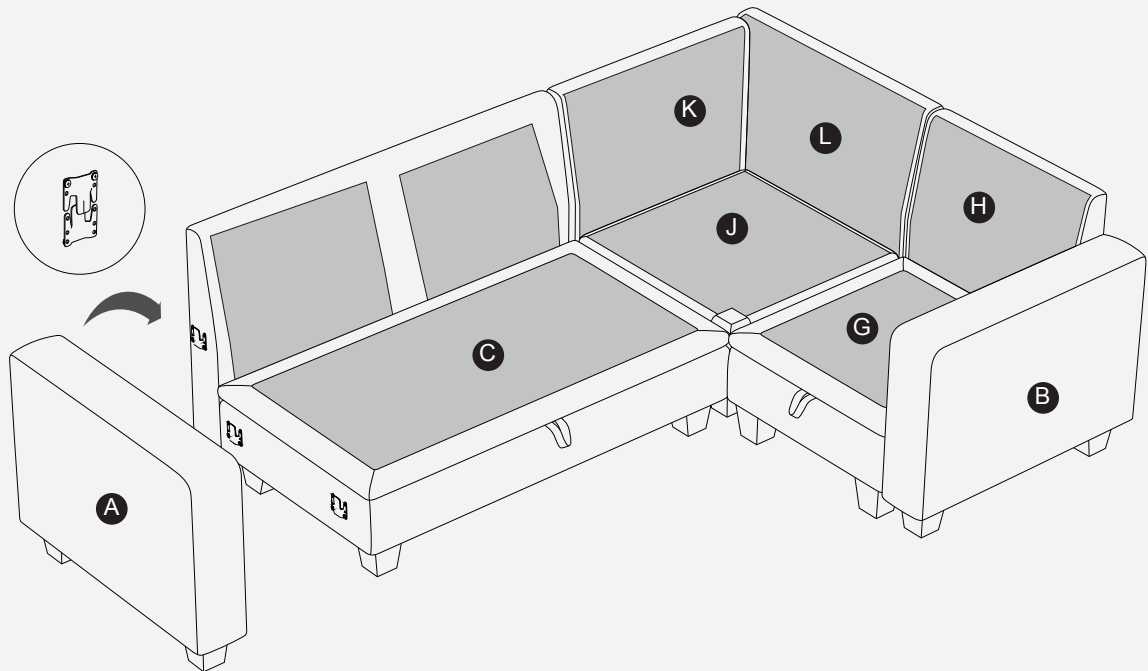

Step11:

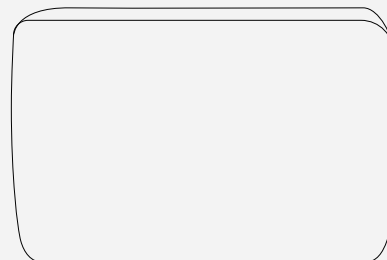
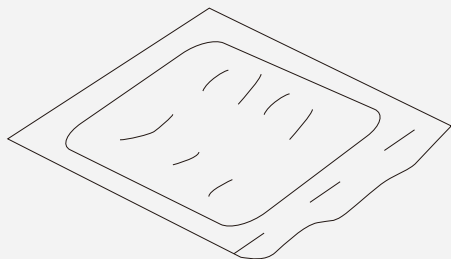
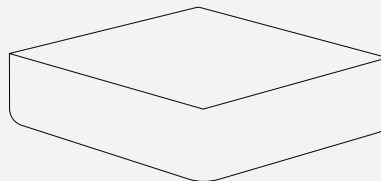
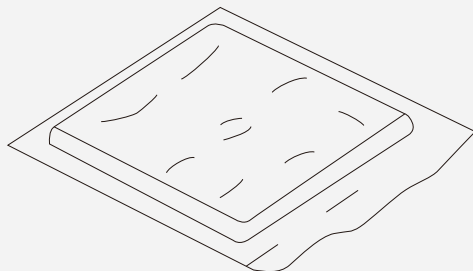

Step12:

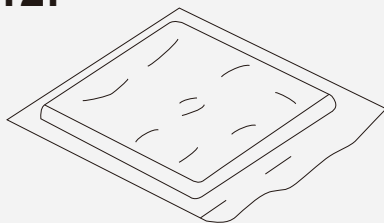

M

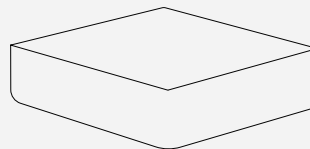

M'

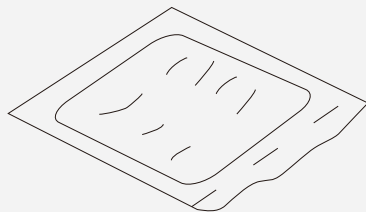

N

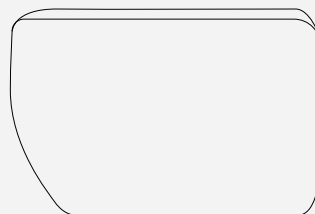

N'

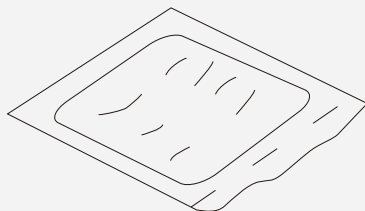

P

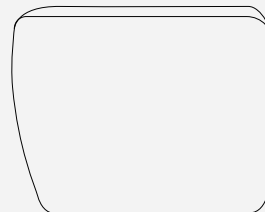

P'

Step13:

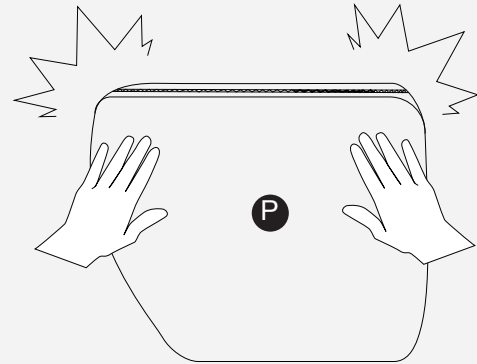
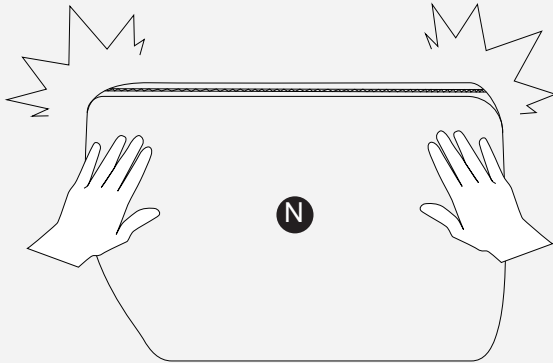
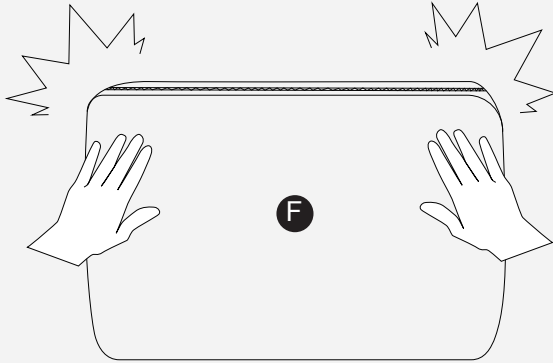

Step13:

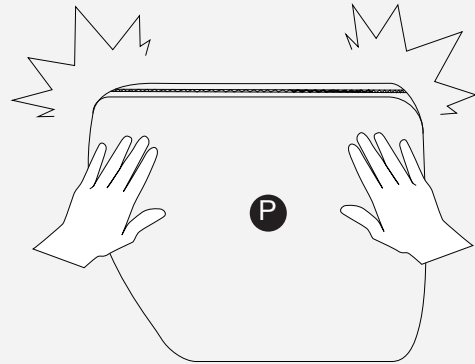
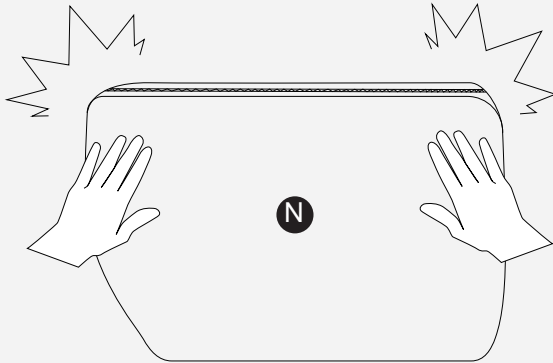
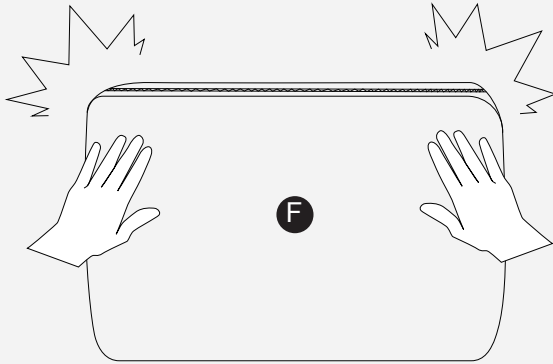

Step14:

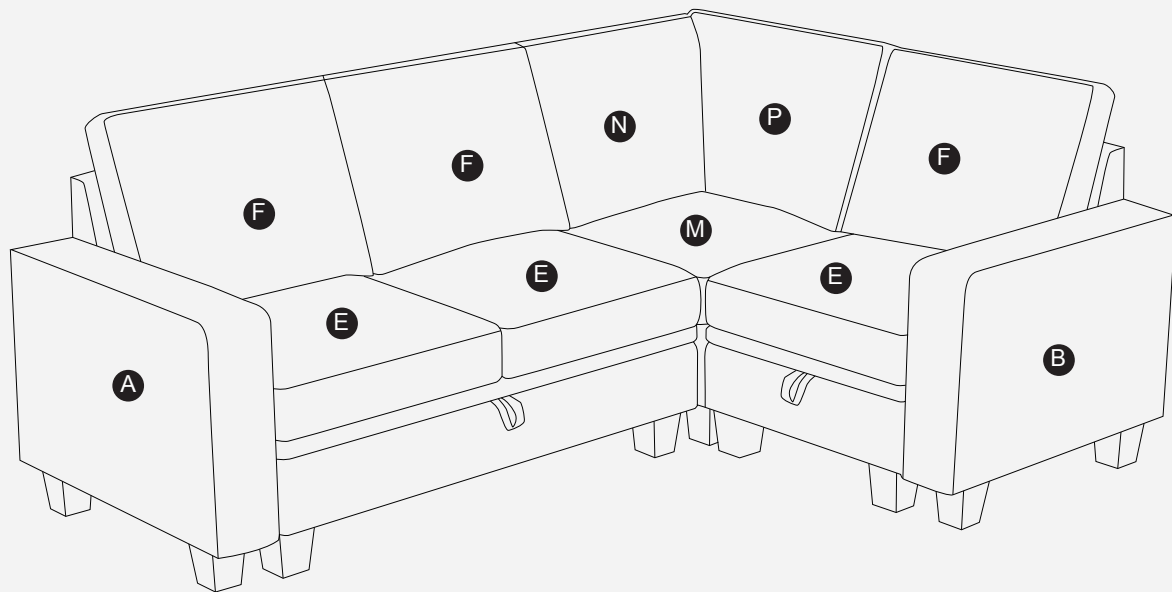

Step15:

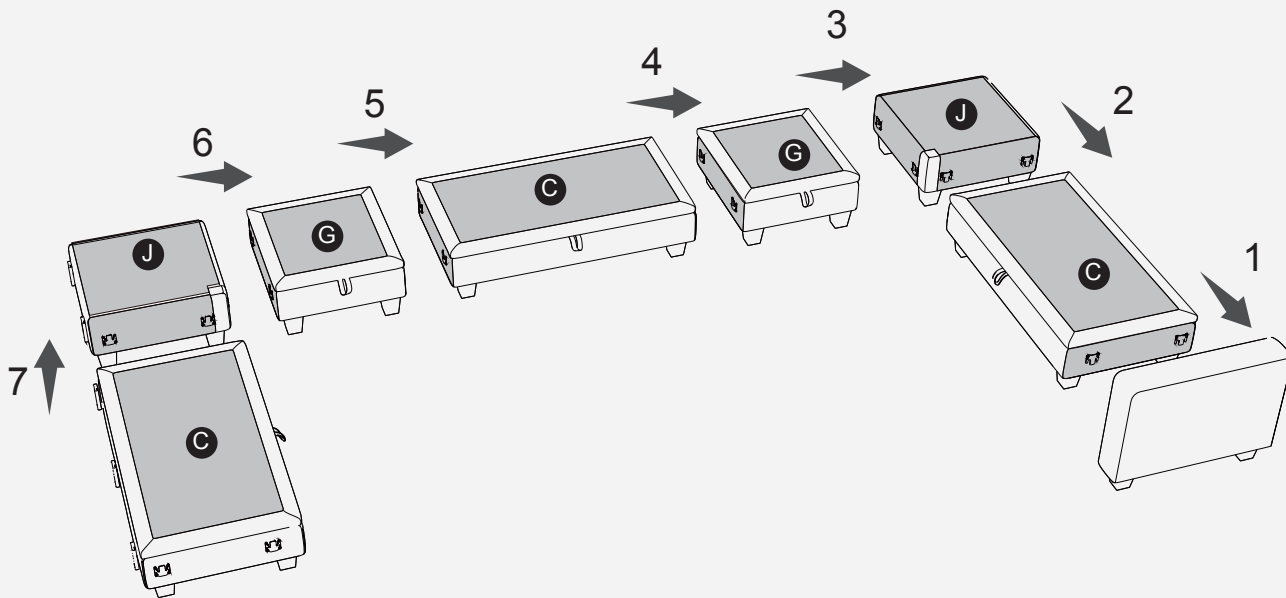

Step16:

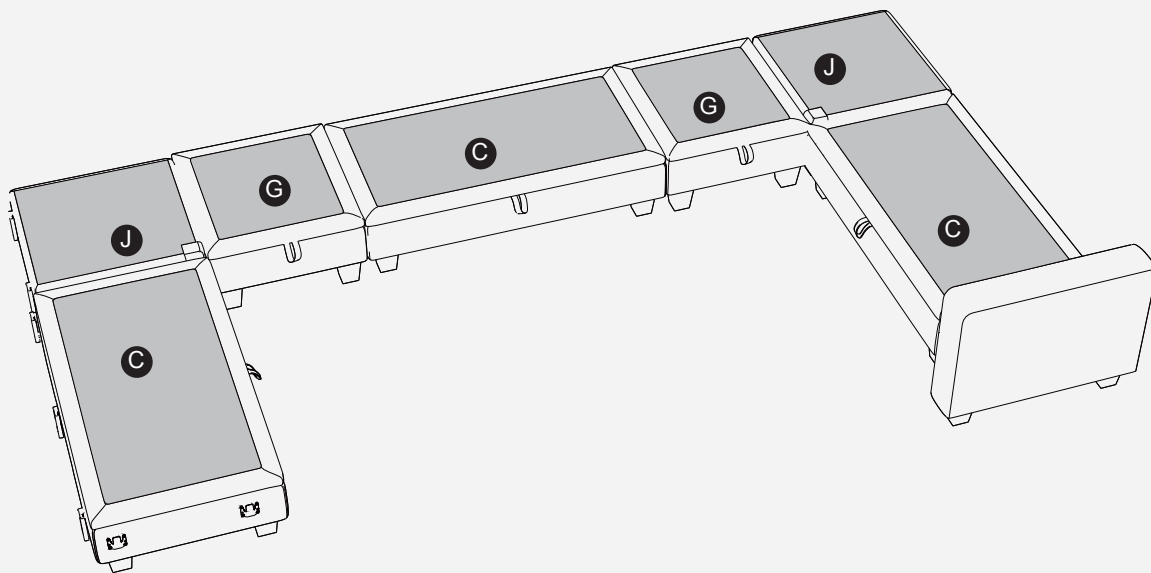

Step17:

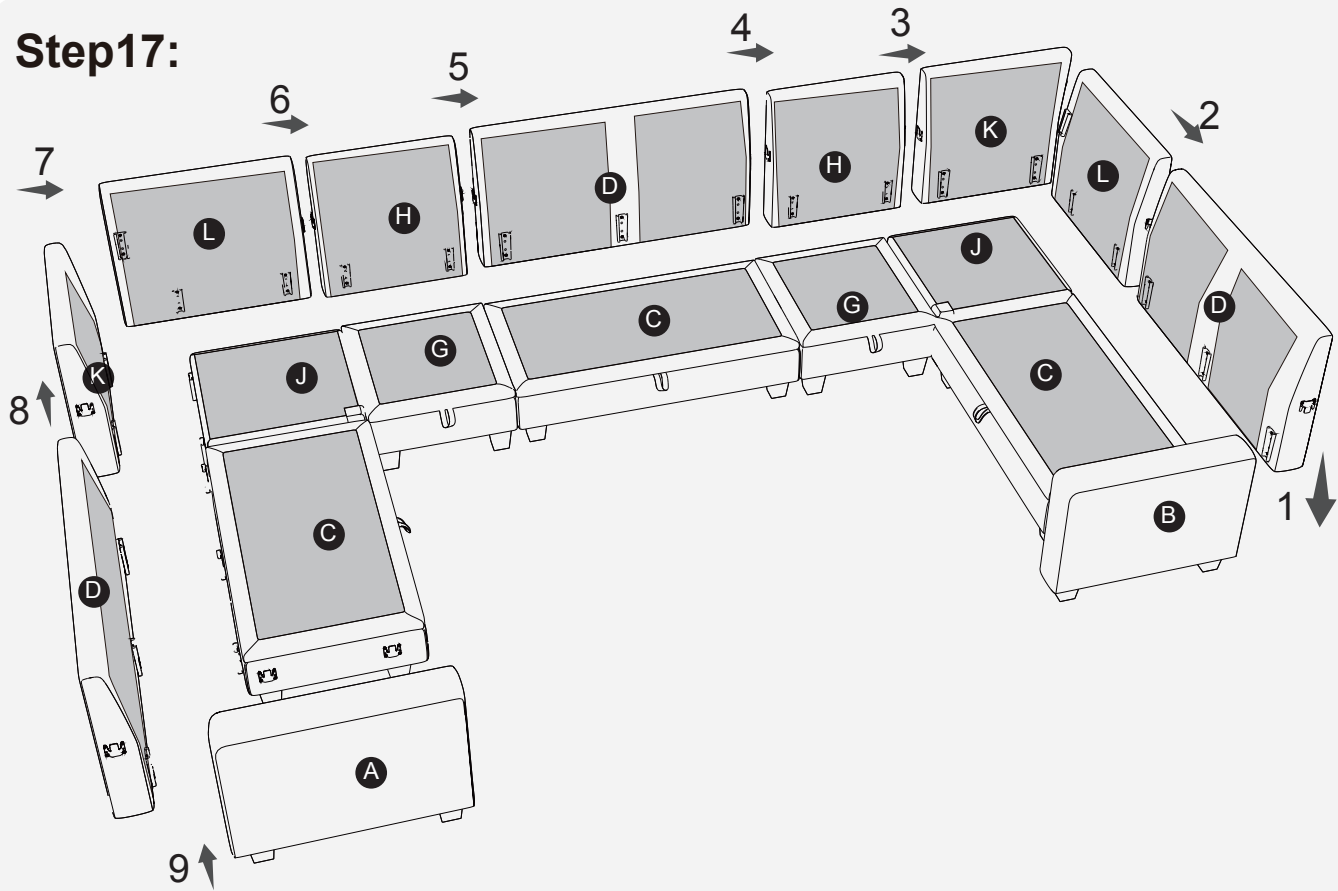

Step18:

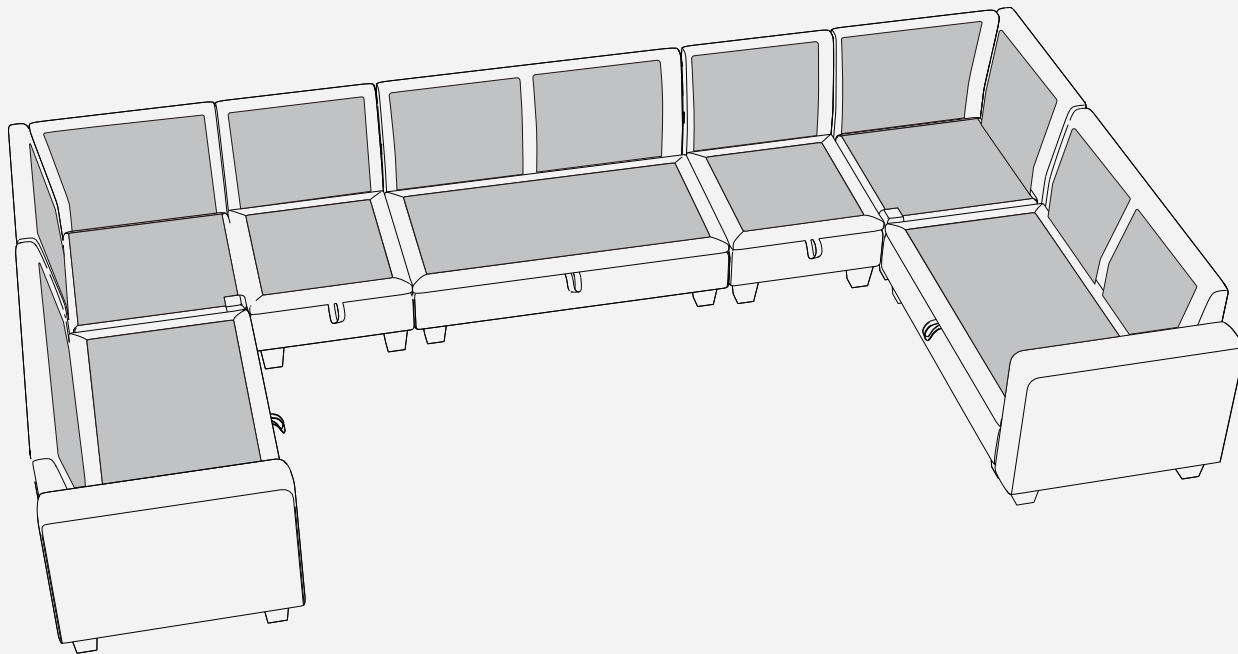

FREE COMBINATION

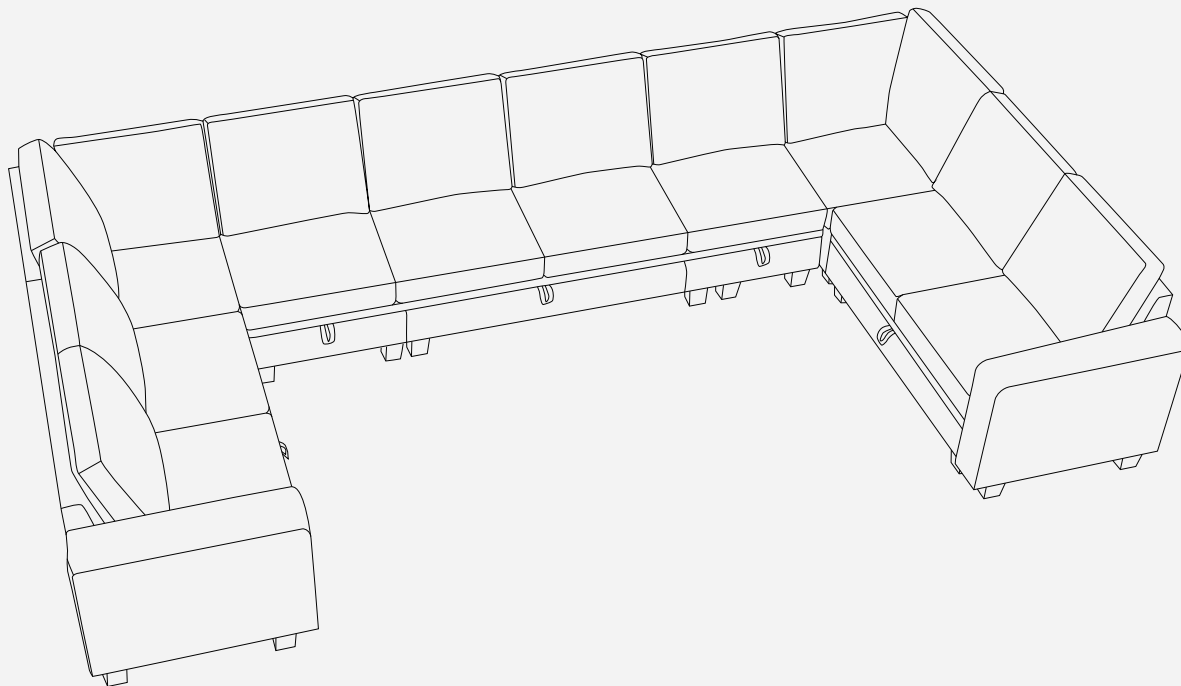

CARTON (1A + 3B + 2C + 2D)