

---

# User Manual

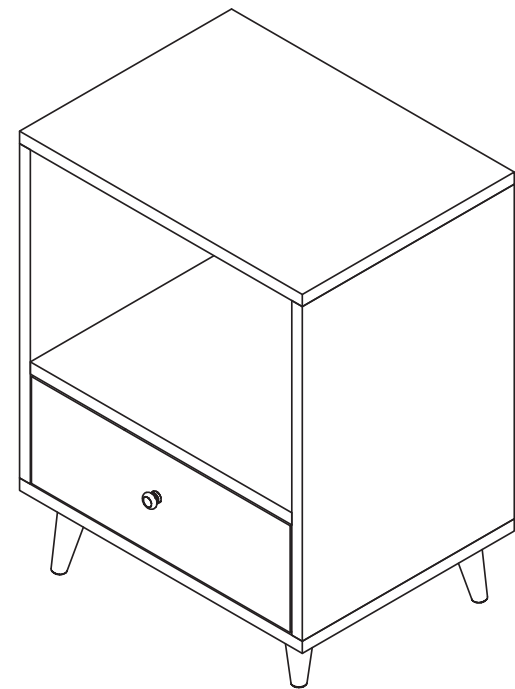

# You need

**1 Tools required**

A Phillips head screwdriver is required for the assembly of this product. (not included)

Power tools should not be used to assemble this product.

**2 1 person is needed**

**3 Take 30 minutes**

Technical Specifications	
Brand	
Size	403*543*302mm

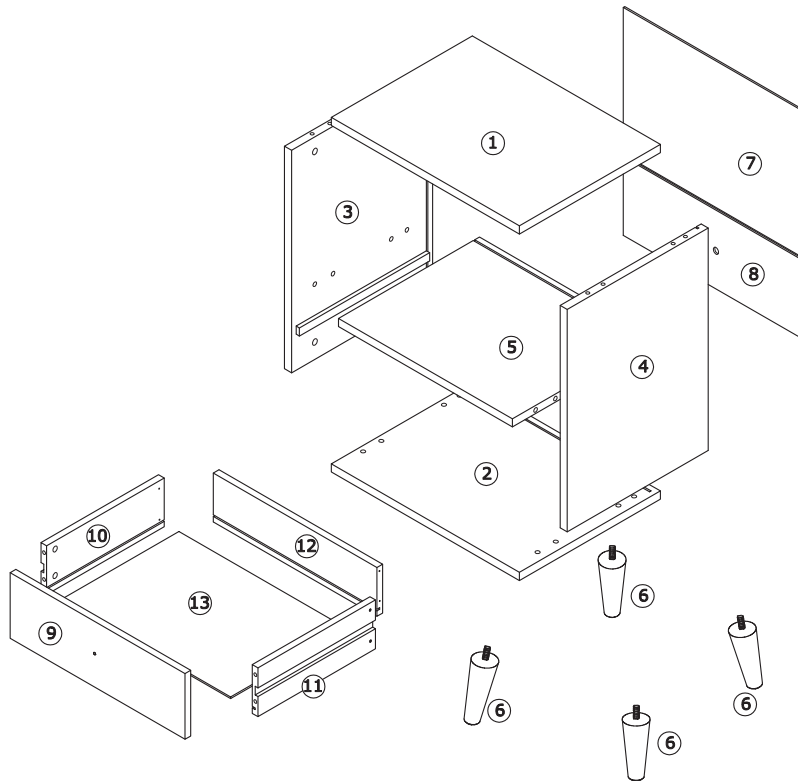

# Hardware List

<p>Ø15x9mm</p> <p>A 16PCS</p>	<p>Ø6x35mm</p> <p>B 16PCS</p>	<p>Ø3x30mm</p> <p>C 4PCS</p>	<p>Ø8x30mm</p> <p>D 12PCS</p>
<p>Ø4x18mm</p> <p>E 1PC</p>	<p>F 1PC</p>	<p>① 1PC</p>	<p>② 1PC</p>
<p>③ 1PC</p>	<p>④ 1PC</p>	<p>⑤ 1PC</p>	<p>⑥ 4PCS</p>
<p>⑦ 1PC</p>	<p>⑧ 1PC</p>	<p>⑨ 1PC</p>	<p>⑩ 1PC</p>
<p>⑪ 1PC</p>	<p>⑫ 1PC</p>	<p>⑬ 1PC</p>	

PRODUCT ASSEMBLY

**!** Check the package contents before getting started !

**STEP 1**

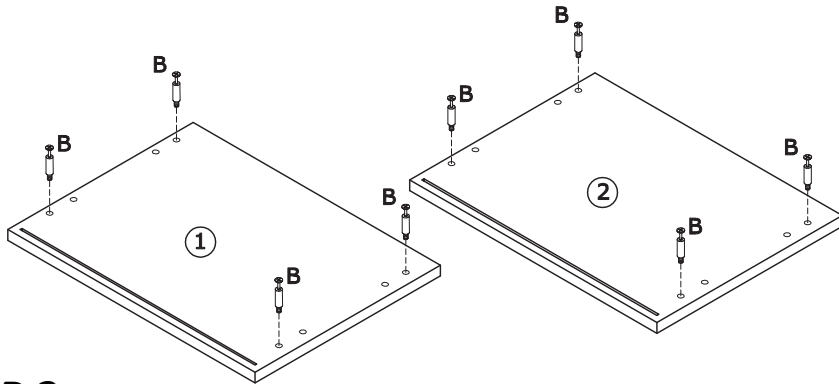
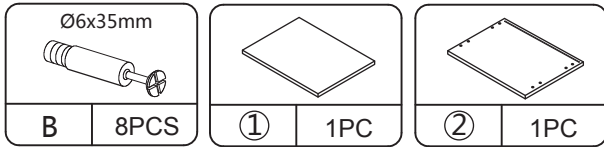

**STEP 2**

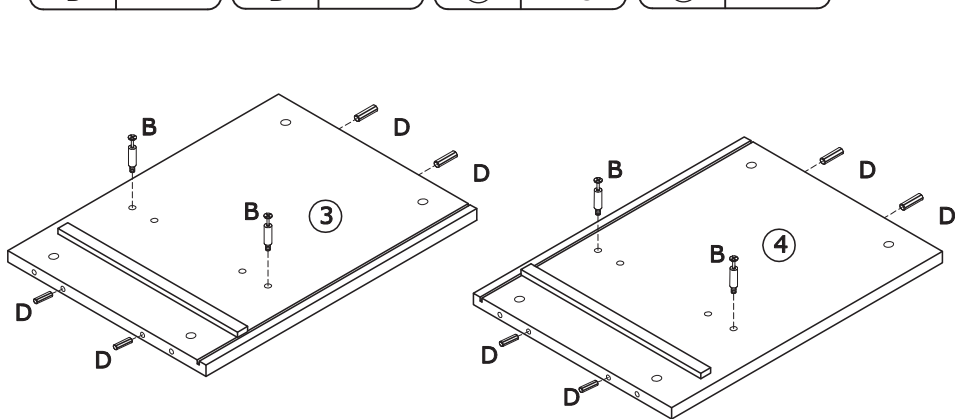
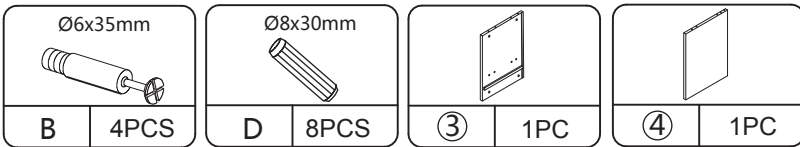

PRODUCT ASSEMBLY

**STEP 3**

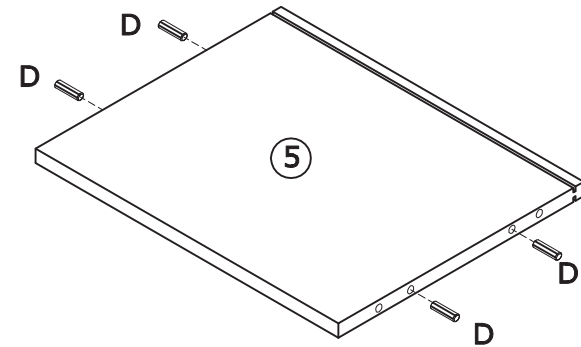
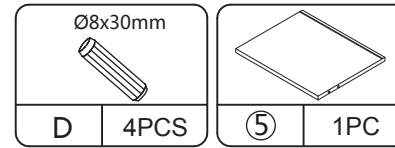

**STEP 4**

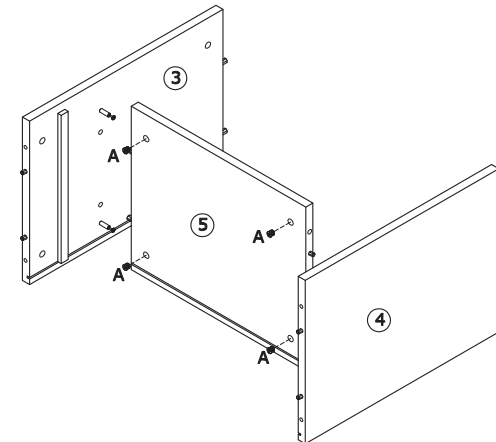
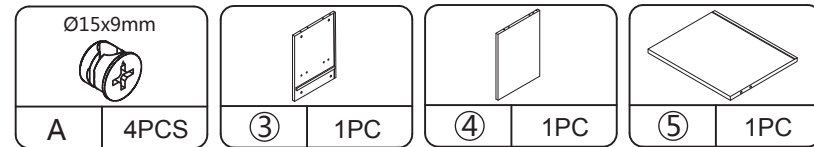

### STEP 5

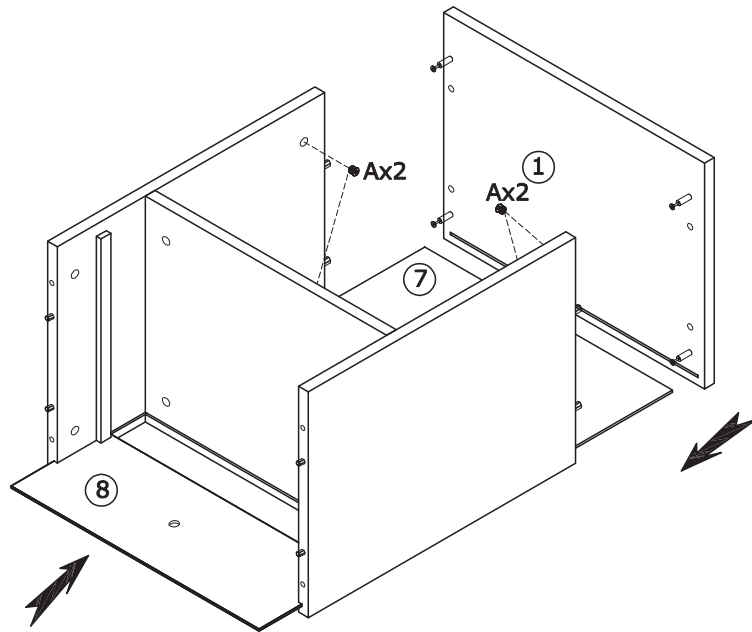
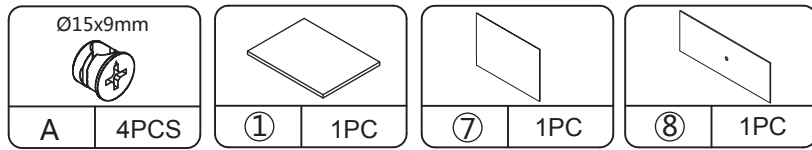

### STEP 6

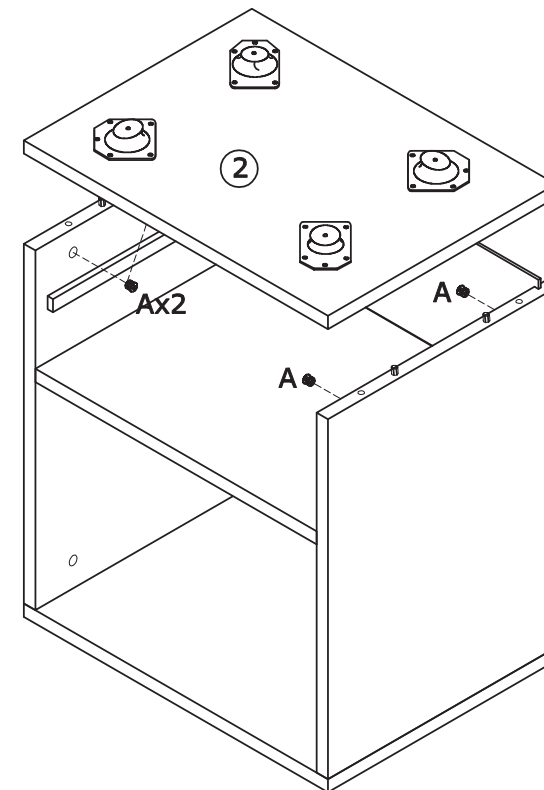
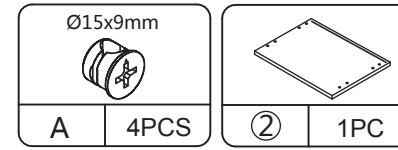

### STEP 7

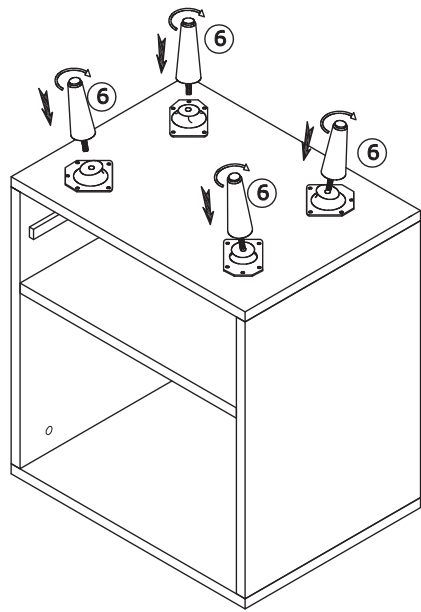
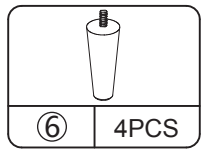

### STEP 8

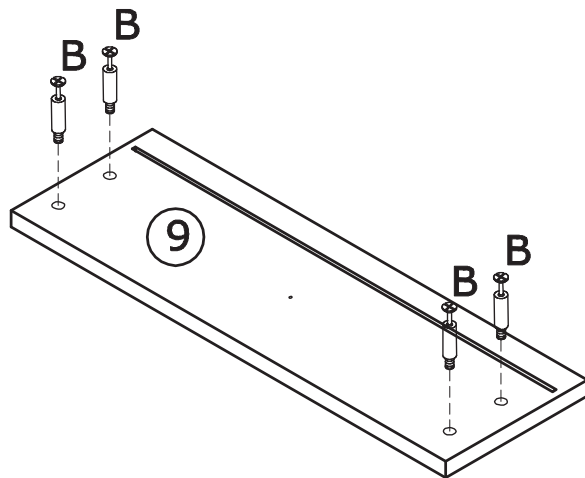
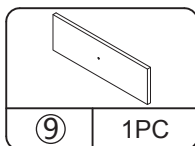
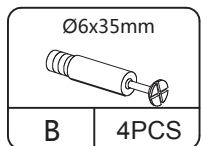

### STEP 9

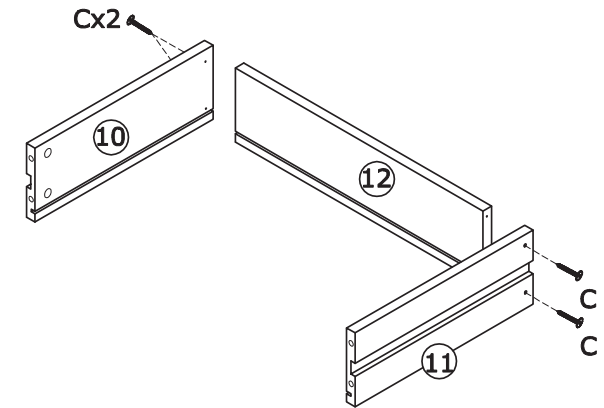
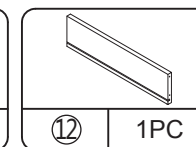
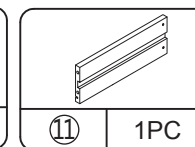
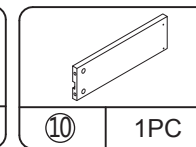
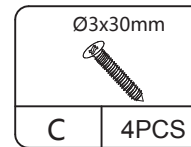

### STEP 10

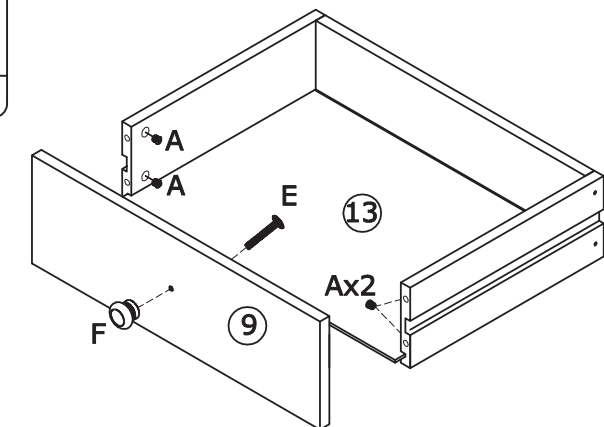
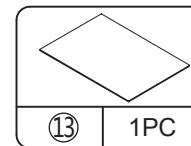
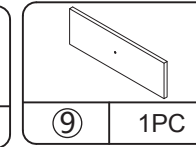
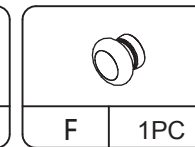
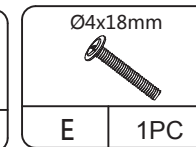
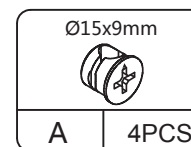

STEP 11

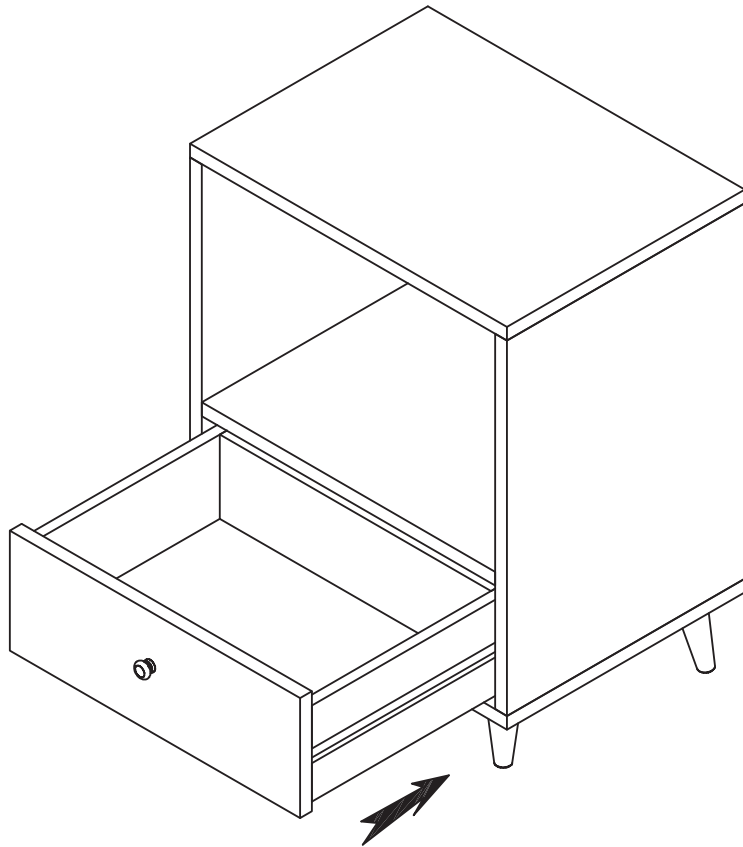

STEP 12

