







Metal Vanity Stool With Back - Golden Bronze Finish

Examine all packaging material for small parts that may have come loose during shipment. Periodic checks are recommended to insure that all components are in proper position, tight and free from damage. Keep this assembly instruction for future reference. Adult assembly is required. This product is designed for residential use only.

CODE	QTY	HARDWARE	
1	12	1/4"*5/8" Allen Bolts	
2	4	1/4"*1" Allen Bolts	
3	16	Φ13*Φ6.2*1MM(1/4") Flat Washers	
4	12	Φ9*Φ7*1MM(1/4") Spring Washers	
5	1	1/4" Allen Wrench	

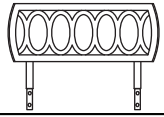
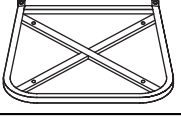
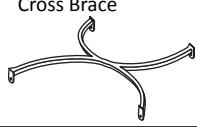
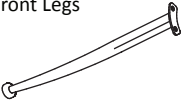
CODE	QTY	COMPONENTS	CODE	QTY	COMPONENTS
A	1	Back Panel 	B	1	Seat Frame 
C	1	Cross Brace 	D	2	Front Legs 
E	1	Back Leg Panel 	F	1	Seat Cushion 

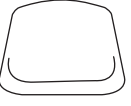
⚠ WARNING

- Do not let any sharp objects touch or rub the surface of the product.
- When assembling, do not let children play around the working area.
- Please confirm all parts are correct before starting the assembly process.
- Do not tighten all bolts and screws completely until the entire unit has been assembled and set up.
- Be careful if using power tools as they can over tighten screws and strip threads.

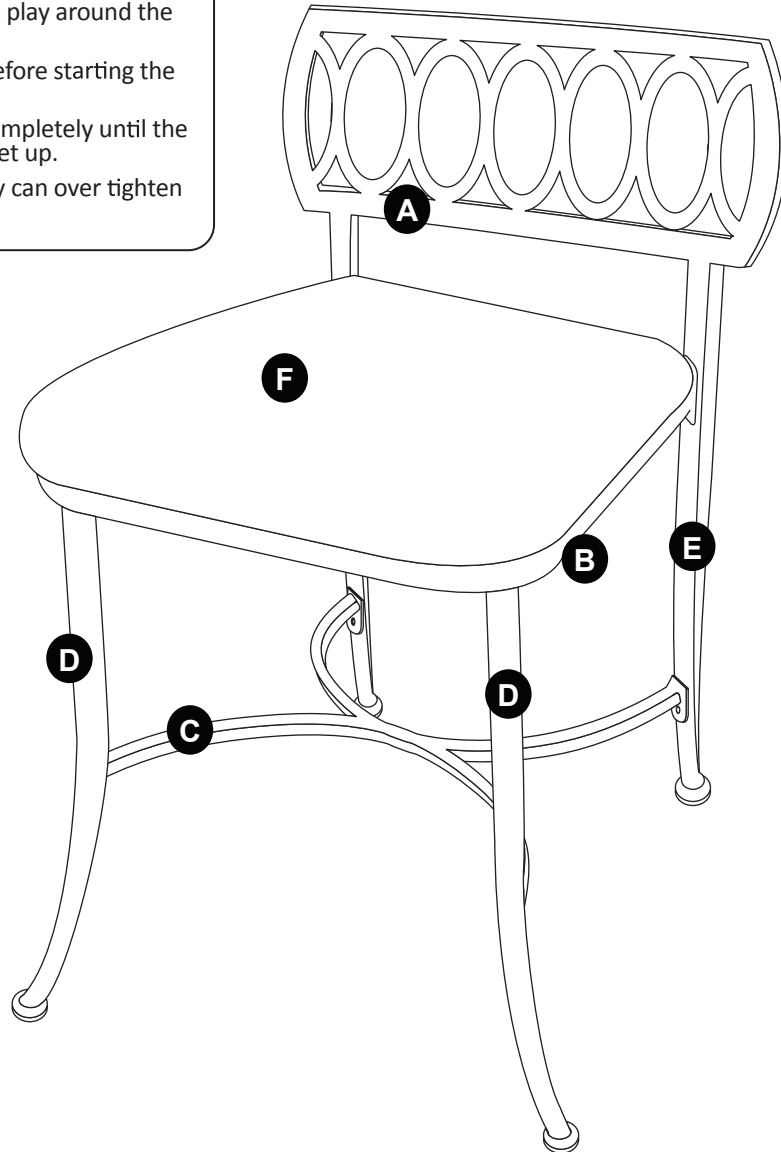

CARE & MAINTENANCE: The touch of a soft cloth is all the maintenance the finish will ever need. Please do not use harsh or abrasive cleaners for polishing, as they may cause damage to the finish. Periodic checks are recommended to make sure that all hardware is securely tightened.

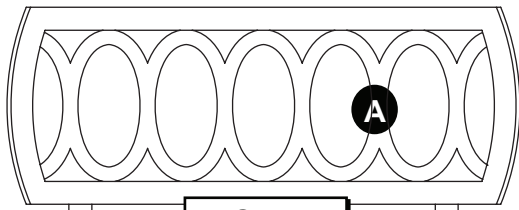

FIGURE 1

STEP 1 - Figure 1

Begin assembly by inserting Back Panel (A) into Back Leg Panel (E) making sure to line up holes.

STEP 2 - Figure 2

Attach Seat Frame (B) to Back Panel (A) by aligning the open holes and securing with 4 Allen Bolts (1), 4 Spring Washers (4), & 4 Flat Washers (3) to secure each in place. Do not tighten bolts for this step.

STEP 3 - Figure 3

Attach Cross Brace (C) to rear legs on Back Leg Panel (E) using 1 Allen Bolt (1), 1 Spring Washer (4), & 1 Flat Washer (3) per side. Do not tighten bolts for this step.

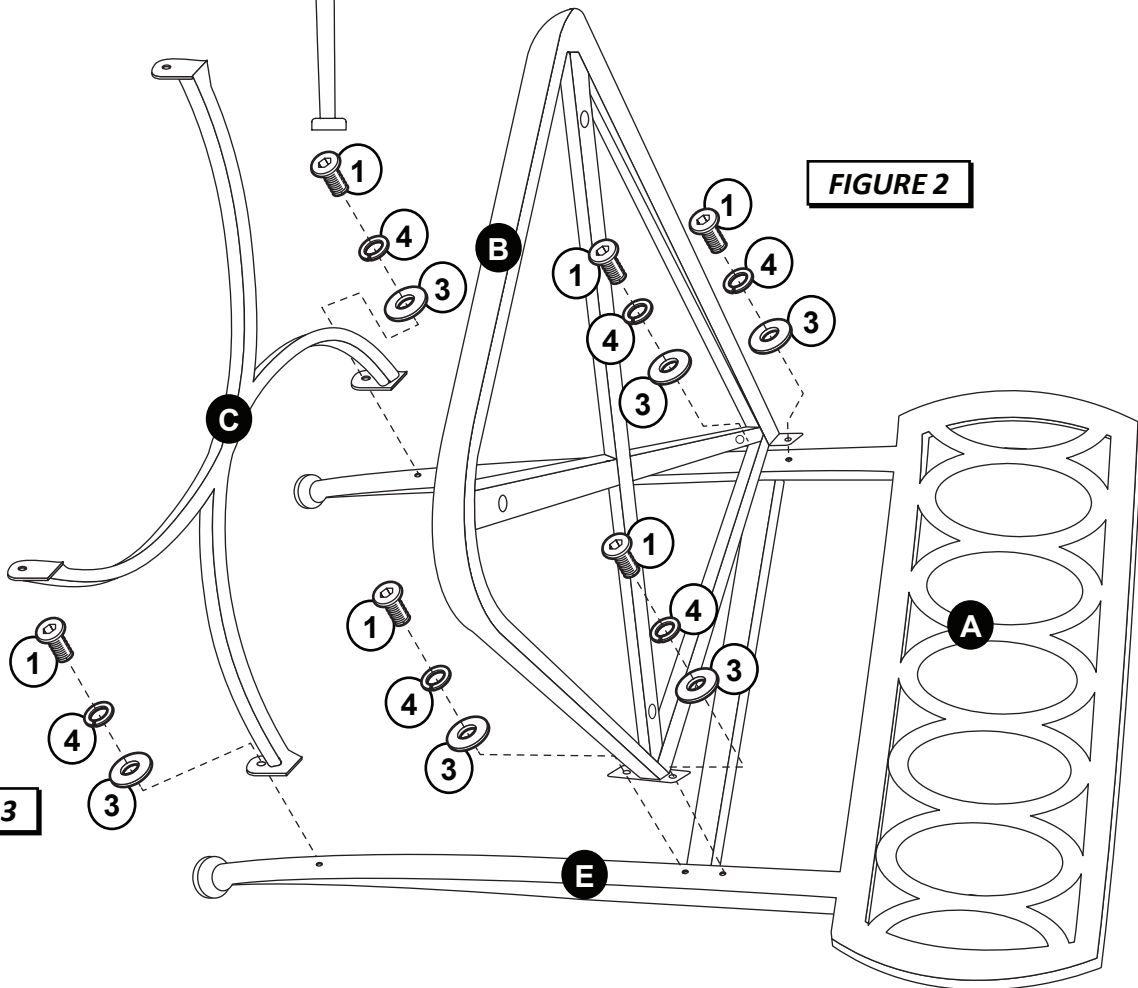
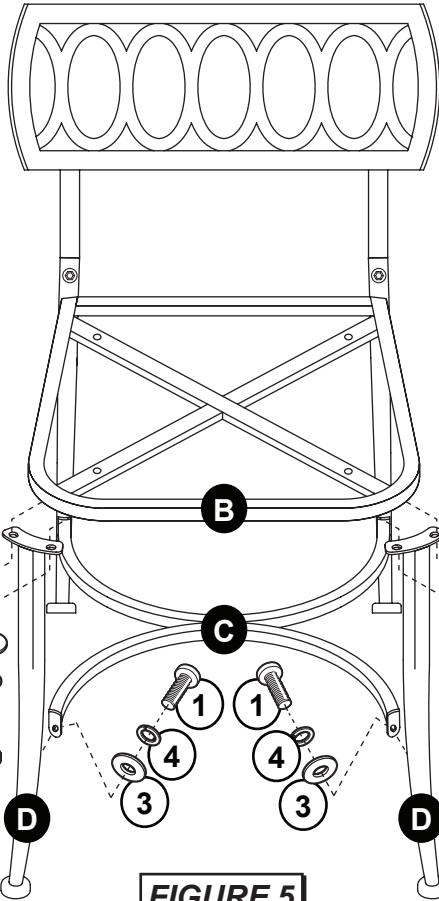

FIGURE 2

FIGURE 3

FIGURE 4



STEP 4 - Figure 4

Next, attach each Front Leg (D) to the bottom of Seat Frame (B) using 2 Allen Bolts (1), 2 Spring Washers (4), & 2 Flat Washers (3) to secure each in place. Do not tighten bolts for this step.

STEP 5 - Figure 5

Attach Cross Brace (C) to Front Legs (D) using 1 Allen Bolt (1), 1 Spring Washer (4), 1 Flat Washer (3). Tighten all bolts using Allen Wrench (5) provided.

FIGURE 5

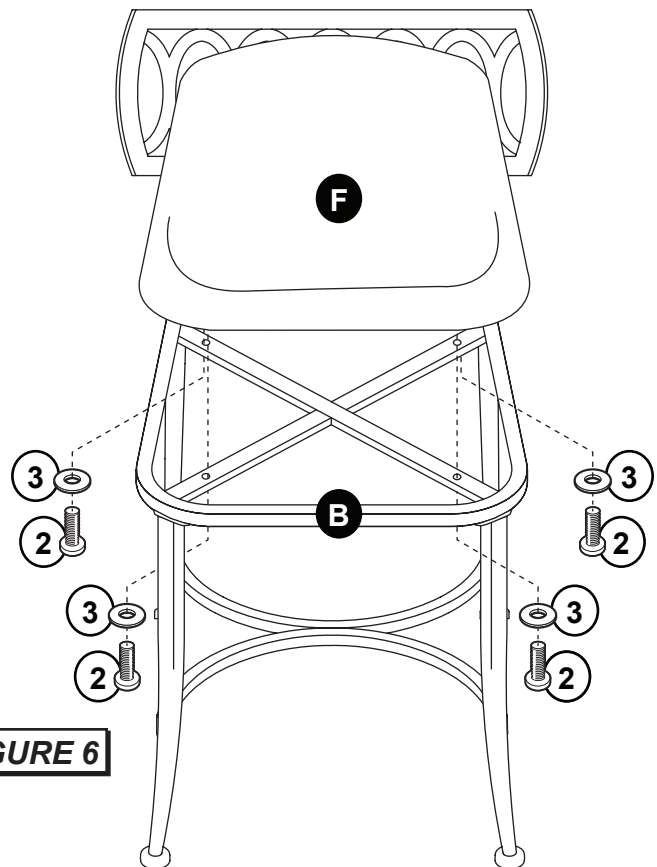

FIGURE 6

STEP 6 - Figure 6

Finally attach Seat Cushion (F) to Seat Frame (B) using 4 Allen Bolts (2) and 4 Flat Washers (3). Tighten all bolts using Allen Wrench (5) provided. The assembly is now complete.