

## LP GAS GRILL USER MANUAL

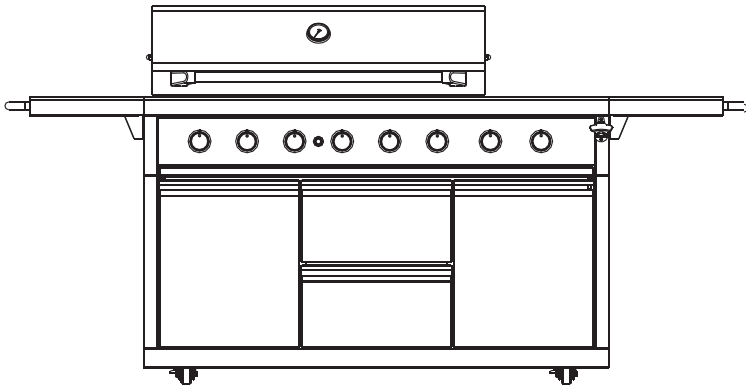

CBU-611-A-L

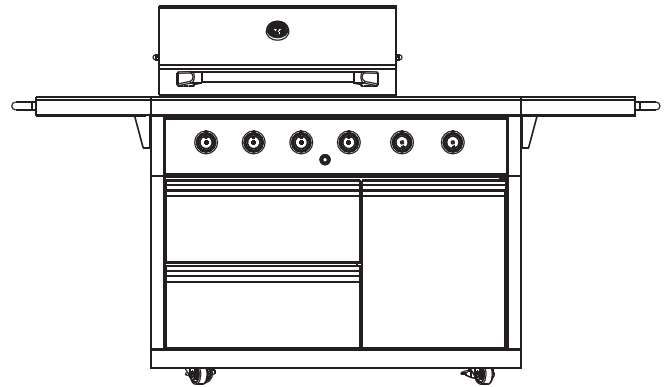

CBU-411-A-L

The instructions shall be marked with directions to the installer to leave them with the consumer and to the consumer to retain them for future reference.



### WARNING

To reduce the risk of fire, burn hazard or other injury, read the Care and Use Manual carefully and completely before using your grill.



### WARNING

The outdoor cooking gas appliance must be isolated from the gas supply piping system by closing its individual manual shutoff valve during any pressure testing of the gas supply piping system at test pressures equal to or less than  $\frac{1}{2}$  psi (3.5 kPa)



### WARNING

This grill is not intended to be installed in or on recreational vehicles and/or boats.



### WARNING

FOR OUTDOOR USE ONLY

## TABLE OF CONTENT

---

Safety Information .....	3
Explosive view and part list .....	7
Installation Instructions .....	11
Operation Instructions .....	24
Care and Maintenance .....	26



### **DANGER**

If you smell gas:

1. Shut off gas to the appliance.
2. Extinguish any open flame.
3. Open lid.
4. If odor continues, keep away from the appliance and immediately call your gas supplier or your fire department.



### **WARNING**

Do not store or use gasoline or other flammable liquids or vapors in the vicinity of this or any other appliance. An LP cylinder not connected for use shall not be stored in the vicinity of this or any other appliance.



**WARNING** – Hazards or unsafe practices which COULD result in severe personal injury or death.



**CAUTION** – Hazards or unsafe practices which COULD result in minor personal injury.



### **WARNING**

Do not try lighting this appliance without first reading the “LIGHTING INSTRUCTIONS” section of this manual.



### **CAUTION**

The grill head is heavy and will require two or more people to lift and position onto grill cart.

**WARNING**

Do not use the grill if the odor of gas is present.

**WARNING**

Never attempt to use damaged equipment. See your local liquid propane dealer for repair.

**WARNING**

Do not install this unit into combustible enclosures. There should be a minimum clearance of 24 inches from all sides to combustible materials.

**WARNING**

Maximum LP gas tank size is 12 inches in diameter by 18-1/2 inches tall. Do not use a tank without an Overfill Prevention Device (OPD), which prevents the tank from being overfilled and possibly damaging your grill.

**WARNING**

Do not leave the grill unattended while cooking.

**WARNING**

Spiders and insects can nest inside the burners of the grill and disrupt gas flow. Inspect the grill at least twice a year.

**CAUTION**

When using the rotisserie burner, remove the warming rack. High heat from the burner may cause the warming rack to bend.

**WARNING**

1. The grill and its individual shut-off valve must be disconnected from the gas supply piping system during any pressure testing in excess of 1/2 PSI (3.5 kpa).

**WARNING**

Check all gas supply fittings for leaks before each use. Do not use the grill until all connections have been checked and do not leak. Do not smoke while leak testing. Never leak test with an open flame.

**WARNING**

This grill is not intended to be installed in or on recreational vehicles and/or boats.

**WARNING**

When lighting, keep your face and hands as far away from the grill as possible.

**WARNING**

Do not store grill indoors unless the cylinder is disconnected. Do not store cylinder in a building, garage, or any other enclosed area, and keep out of reach of children at all times.

**WARNING**

Failure to properly place the burner over the orifice could cause a fire to occur behind and beneath the valve panel, thereby damaging the grill and making it unsafe to operate.

**CAUTION**

When using a match to light the grill, make sure to use the attached lighting rod.

**CAUTION**

Before cleaning, make sure the gas supply and control knobs are in the "OFF" position and the burners have cooled.

## BEFORE LIGHTING

---

Inspect the gas supply hoses prior to turning on the gas. If there is evidence of cuts, wear, or abrasion, it must be replaced prior to use.

Only the pressure regulator and hose assembly supplied with the unit should be used. Never substitute regulators for those supplied with the grill. Contact customer service for proper replacement.

Screw the regulator onto the cylinder. Leak check the hose and regulator connections with a soap and water solution before operating the grill (See "Leak Testing" instructions on page 13).

Do not turn on the gas at the LP gas cylinder unless the gas hose is properly connected to the side burner gas pipe system and all burner valves are in the "OFF" position.

Keep a spray bottle of soapy water near the grill and check the connections before each use.



### LP GAS CYLINDER WARNING

1. Do not store or use gasoline or other flammable vapors and liquids in the vicinity of this or any other appliance.
2. A liquid propane cylinder not connected for use should not be stored in the vicinity of this or any other appliance.
3. Do not store spare liquid propane gas cylinders under or near this appliance.
4. Never fill the cylinder beyond 80 percent capacity.
5. Liquid propane cylinders must be fitted with an Overfill Protection Device (OPD).
6. If the information above is not followed exactly, a fire resulting in death or serious injury could occur.

## SAFETY PRACTICES TO AVOID INJURY

---

When properly cared for, your grill will provide safe, reliable service for many years. However, extreme care must be used as the grill produces intense heat that can increase accident potential.

When using this appliance basic safety practices must be followed, including the following:

Do not repair or replace any part of the grill unless specifically recommended in this manual. All other service should be referred to a qualified technician.

The grill is for outdoor use only.

The grill is not intended to be installed in or on recreational vehicles and/or boats.

Children should not be left alone or unattended in an area where the grill is being used. Do not allow children to sit, stand or play on or around the grill at any time.

Do not store items of interest to children around or below the grill or cart. Do not allow children to crawl inside the cart.

Never let clothing, pot holders or other flammable materials come in contact with or too close to any grate, burner or hot surface until it has cooled. The fabric could ignite, causing serious personal injury.

For personal safety, wear proper apparel. Loose fitting garments or sleeves should never be worn while using this appliance. Some synthetic fabrics are highly flammable and should not be worn while cooking.

Only certain types of glass, ceramic, earthenware, or other glazed utensils are suitable for grill use.

Other types of materials may shatter with sudden temperature changes. Use only low or medium heat settings in accordance with the manufacturer's guidelines.

Do not heat unopened food containers as a build-up of pressure may cause the containers to burst.

Use a covered hand when opening the grill lid. Never lean over an open grill.

When lighting a burner, always pay close attention to what you are doing. Make certain you are aware of which burner you are lighting so that your body and clothing remain clear of open flames.

When using the grill, do not touch the grill rack, burner grate or immediate surroundings as these areas become extremely hot and could cause burns. Use only dry potholders. Moist or damp potholders on hot surfaces may cause steam burns. Do not use a towel or bulky cloth in place of potholders.

Do not allow potholders to touch hot portions of the grill rack.

Grease is flammable. Let hot grease cool before attempting to handle it. Do not allow grease deposits to collect in the grease tray at the bottom of the grill's firebox. Clean the grease tray often.

Do not use aluminum foil to line the grill racks or grill bottom. This can severely upset combustion airflow or trap excessive heat in the control area.



**WARNING**

Do not try lighting this appliance without first reading the "LIGHTING INSTRUCTIONS" section of this manual.



**CALIFORNIA PROPOSITION 65 WARNING**

The burning of gas fuel generates some byproducts, which are known by the State of California to cause cancer or reproductive harm. To minimize exposure to these substances, always operate this unit according to the care and use manual, ensuring you provide good ventilation when cooking with gas.



**TESTED IN ACCORDANCE WITH ANSI Z21.58 LATEST STANDARD and CSA 1.6-2012 STANDARED FOR OUTDOOR COOKING GAS APPLIANCES. THIS GRILL IS FOR OUTDOOR USE ONLY.**

Check your local building codes for the proper method of installation. In the absence of local codes, follow either the National Fuel Gas Code, ANSI Z223.1/NFPA 54, or CAN/CGA-B149.1, Natural Gas and Propane Installation Code, Electrical Code, ANSI/NFPA 70

For proper lighting and performance of the burners, keep the burner ports clean. It is necessary to clean them periodically for optimum performance. The burners will only operate in one position and must be mounted correctly for safe operation.

Exercise caution when cleaning grill. To avoid steam burns, do not use a wet sponge or cloth to clean the grill while it is hot. Some cleaners produce noxious fumes or can ignite if applied to a hot surface.

Never use a dented or rusty propane cylinder.

Turn off all control knobs and make certain the grill is cool before using any type of aerosol cleaner on or around it. The chemical that produces the spraying action could, in the presence of heat, ignite or cause metal parts to corrode.

Do not use the grill to cook excessively fatty meats or other products, which promote flare-ups.

Do not operate the grill under unprotected combustible constructions. Use only in well ventilated areas. Do not use in buildings, garages, sheds, breezeways or other such enclosed areas.

This unit is intended for outdoor use only.

Keep the areas surrounding the grill free from combustible materials including, fluids, trash, and vapors such as gasoline or charcoal lighter fluid. Do not obstruct the flow of combustion and ventilation air. If the unit is stored indoors, make sure it is cool.

Do not use briquettes of any kind in the grill.

This liquid propane gas grill is designed for optimum performance without the use of briquettes. Do not place briquettes on the flame tamers as this will block the vent to the grill burners. Adding briquettes can damage ignition components, thus voiding the warranty.

Keep the back of the cart free and clear from debris. Keep any electrical supply cord and the fuel supply hose away from any heated surface.

Never use the grill in extremely windy conditions. If located in a consistently windy area (oceanfront, mountaintop, etc.), a windbreak will be required. Always adhere to the clearance specifications.

## PLACEMENT OF THE GRILL

---

Outdoor cooking appliances should not be used under overhead combustible construction.

When determining a suitable location take into account concerns such as exposure to wind, proximity to traffic paths, and keeping gas supply lines as short as possible.

Place the grill in well-ventilated areas. Never place the grill in a building, garage, breezeway, shed or other such enclosed areas. During heavy use, the grill will produce a lot of smoke.



### **WARNING**

**Electrical Grounding Instructions for Transformer** – This appliance (Transformer) is equipped with a plug and should be plugged directly into a properly grounded receptacle. When installed, must be electrically grounded in accordance with local codes or in the absence of local codes, with the National Electrical Code, ANSI/NFPA 70 or the Canadian Electrical Code, CSA C22.1. DO NOT cut or remove the grounding prong from this plug.

1. To protect against electrical shock, do not immerse cord or plugs in water or other liquids.
2. Unplug from the outlet when not in use and before cleaning. Allow to cool before putting on or taking off parts.
3. Do not operate any outdoor cooking gas appliance with a damaged cord, plug, or after the appliance malfunctions or has been damaged in any manner. Contact the manufacturer for repair.
4. Do not let the cord hang over the edge of a table or hot surface.
5. Do not use an outdoor cooking gas appliance for purposes other than intended.
6. When connecting, first connect plug to the outdoor cooking gas appliance then plug appliance into the outlet.
7. Use only a Ground Fault Interrupt (GFI) protected circuit with this outdoor cooking gas appliance.
8. Never remove the grounding plug or use with an adapter of 2 prongs.
9. Use only extension cords with 3 prongs grounding plug, rated for the power of the equipments, and approved for outdoor use with a W-A marking.

Explosive view

# CBU-611-A-L

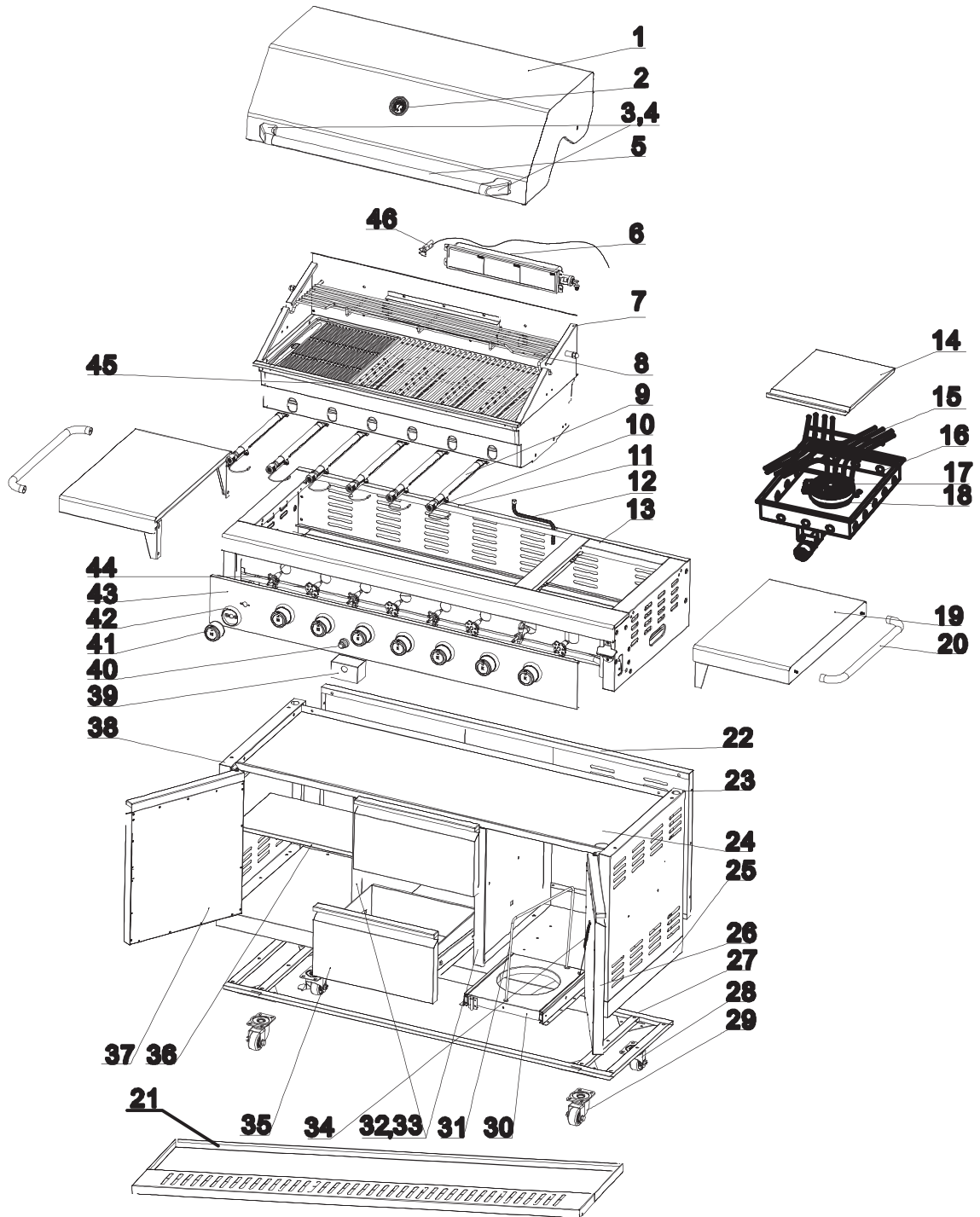

**REPLACEMENT PARTS LIST**

**CBU-611-A-L**

Part No	Part Name	Part No	Part Name
1	Hood assembly	26	Right door
2	Temperature gauge	27	Trolley support rack
3/4	Handle seat	28	Locking castors
5	Handle	29	Casters
6	Back burner	30	Gas cylinder support
7	Fire box	31	Gas cylinder locking rack
8	warming rack	32	Trolley inner panel
9	Burner	33/34	Manual ignition
10	Burner igniter	35	Drawer
11	Fire box support assembly	36	Storage layer
12	Back burner gas tube	37	Left door
13	Side burner support	38	Trolley left panel
14	Side burner lid	39	Heat isolation panel
15	Side burner grid	40	Pulse ignition
16	Soup tray	41	Knob
17	Side burner igniter	42	Knob seat
18	Side burner	43	Control panel
19	Side table	44	Valves
20	Side table handle	45	Grates
21	Drip tray	46	Back burner igiter
22	Trolley back panel		
23	Trolley right panel		
24	Heat isolation panel		
25	Trolley bottom panel		

Explosive view

# CBU-411-A-L

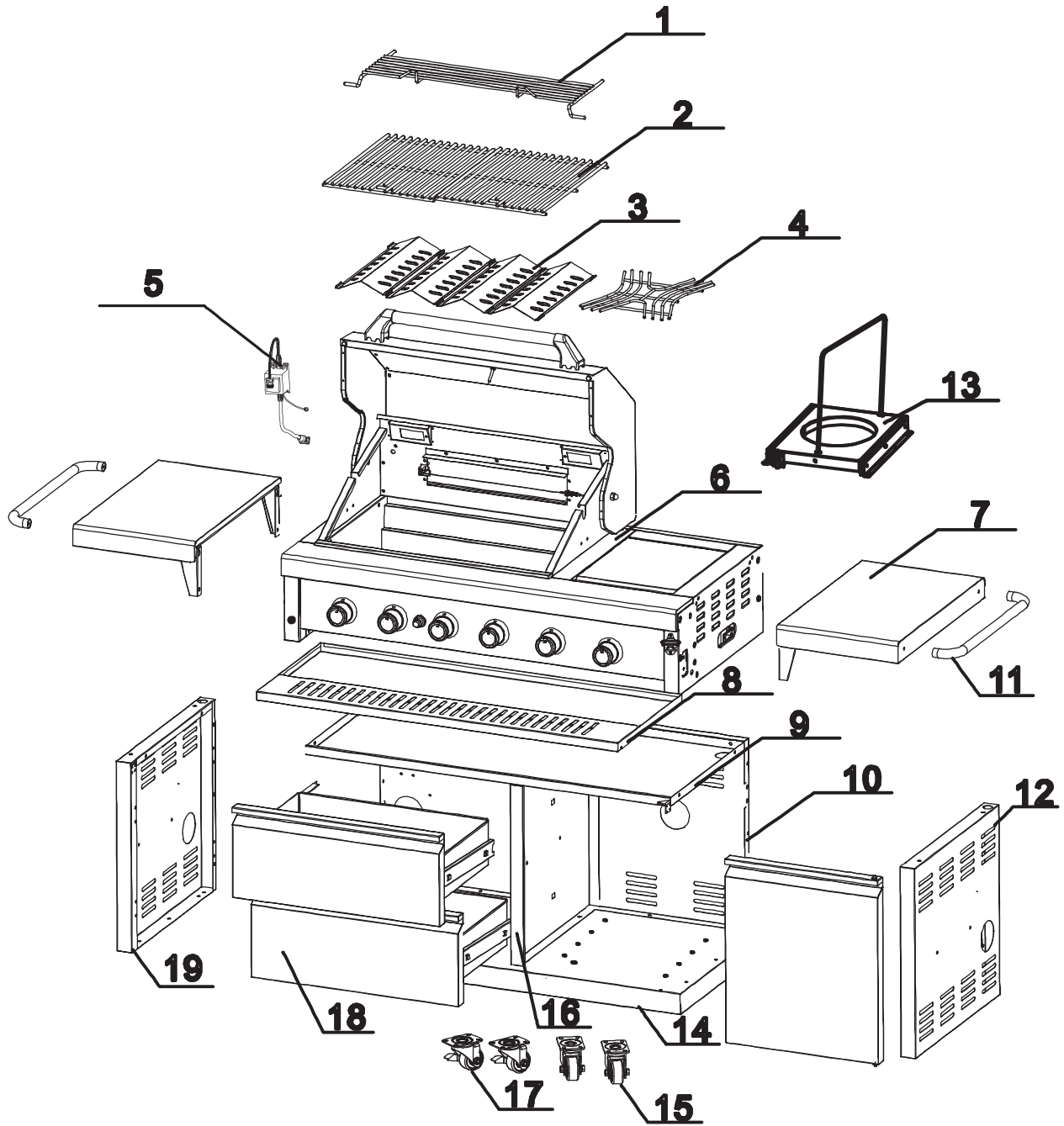

**REPLACEMENT PARTS LIST****CBU-411-A-L**

Part No	Part Name	Part No	Part Name
1	Warming rack	11	Side table handle
2	Cooking grate	12	Trolley right panel
3	Flame tamer	13	Gas cylinder support
4	Cooking grate for side burner	14	Trolley bottom plate
5	Transformer	15	Castors without brake
6	Firebox	16	Trolley inner division panel
7	Side table	17	Castors with brake
8	drip tray	18	drawer
9	Trolley top panel	19	Trolley left panel
10	Trolley rear panel		

## Installation instruction

1. Lock the side shelves to the grill with screws AA  
Fig. 2

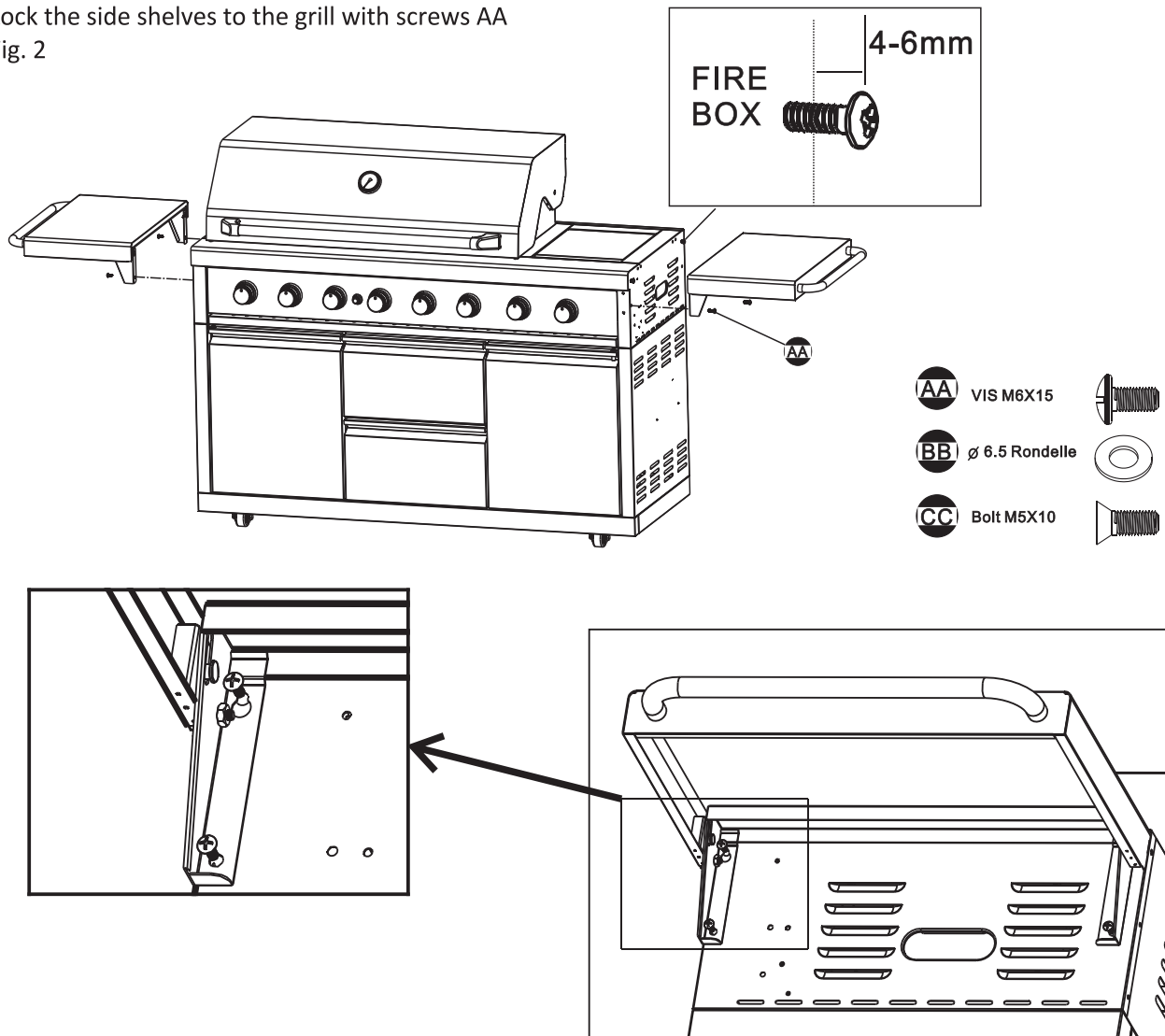

2. Put the AA size battery into the battery box  
Fig.3

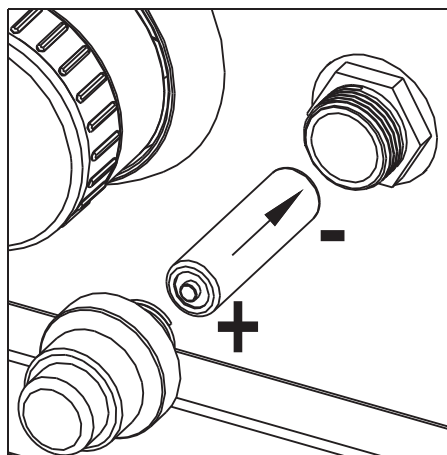

### 3. Bottle opener Assembly

Lock the bottle opener to the grill with screws CC

Fig. 4

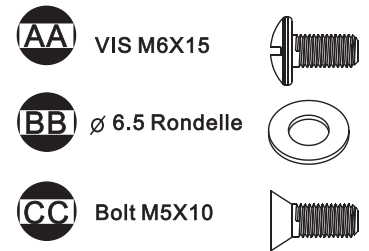
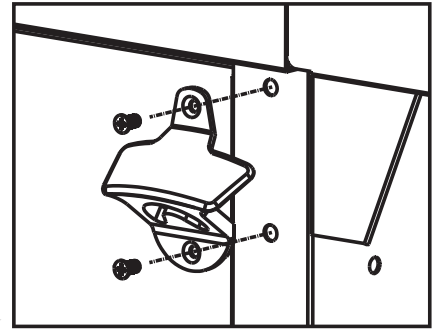
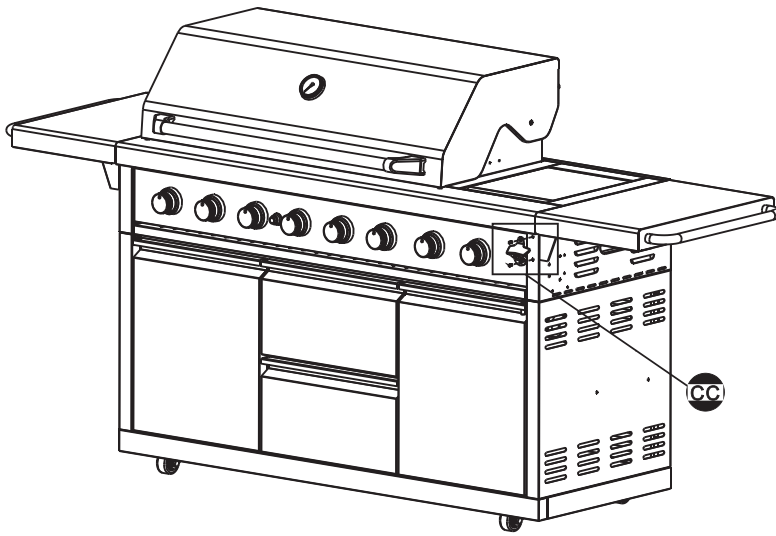

### 4. Place the gas cylinder

Pull out the gas cylinder support, put the gas cylinder on and fasten with the locking rack

Fig.5

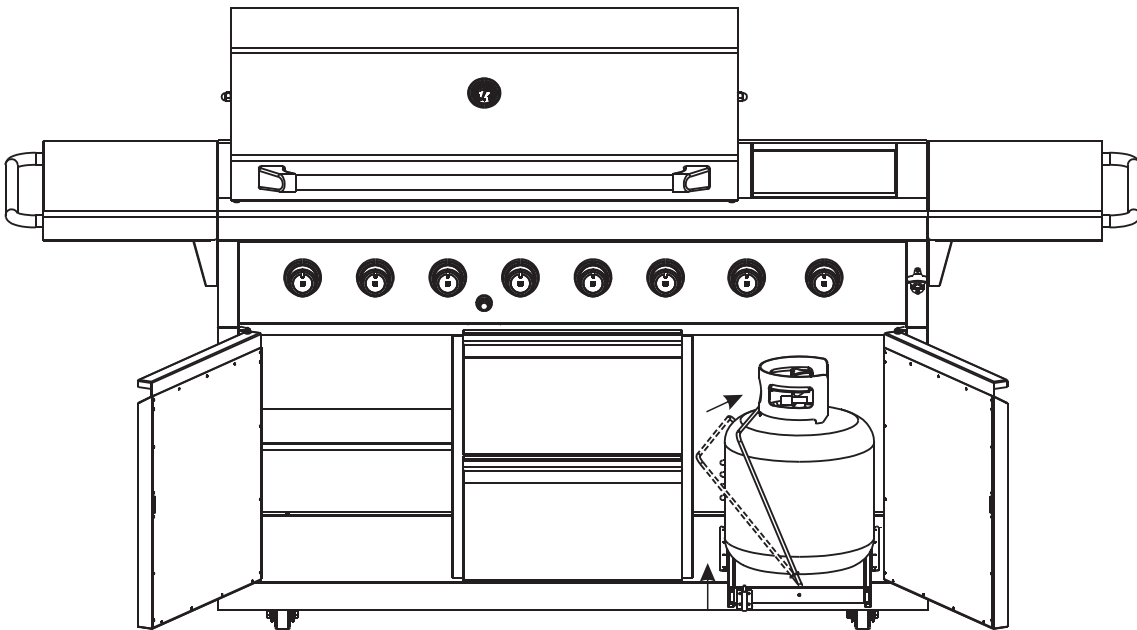

### 5. Liquid Propane Hook-Up

Attach the regulator to the propane cylinder by turning the regulator handle clockwise as shown in Fig. 6. If the outdoor cooking appliance is not in use, the gas must be turned "OFF" at the Liquid Propane cylinder.

**Check all gas supply fittings for leaks before each use. Do not use the grill until all connections have been checked and do not leak (see "Leak Testing" instructions on page 17).**

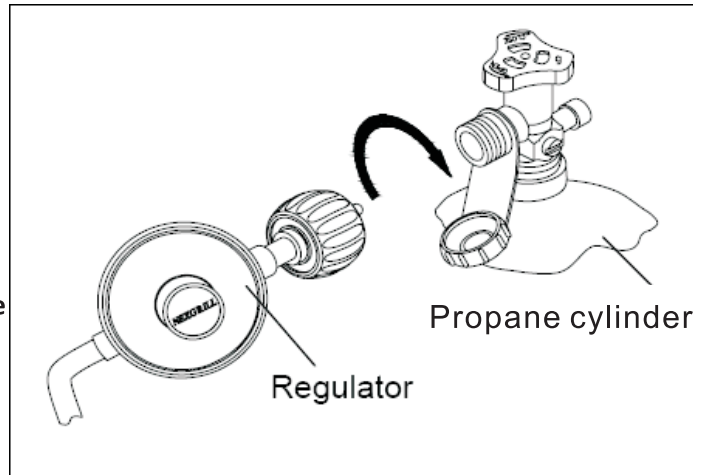
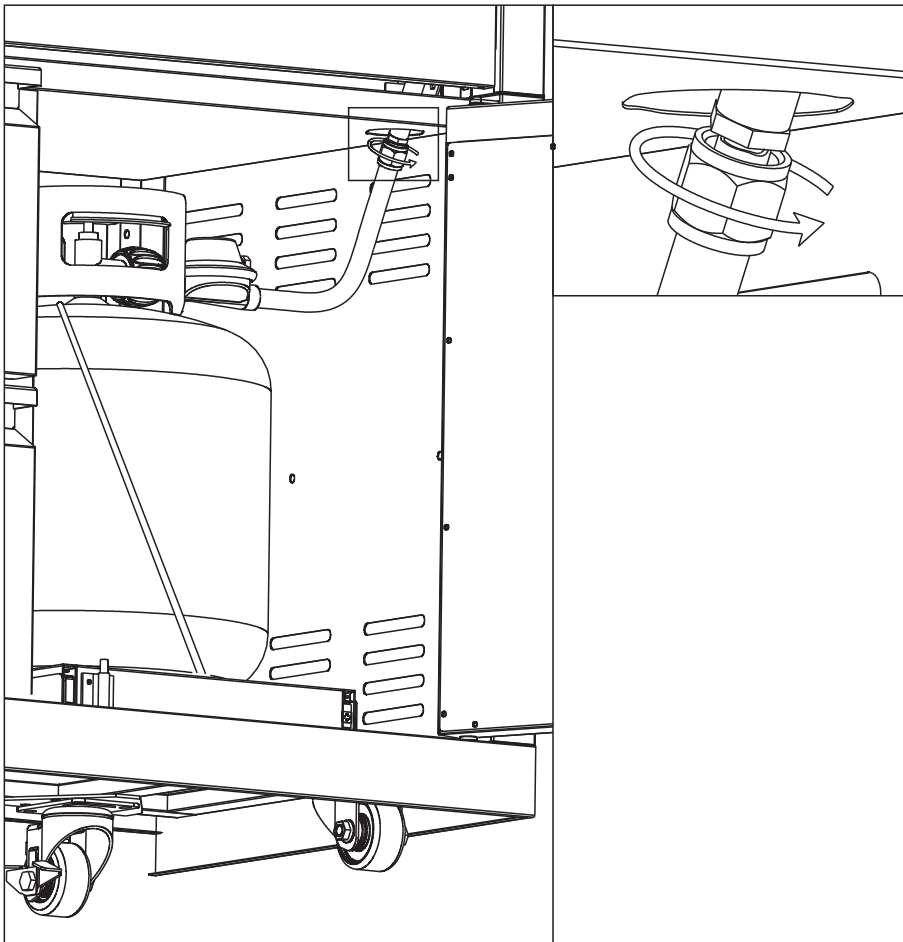

Fig. 6

### 6. Connect the hose to the grill with a wrench

Fig.7



## 7. Manual Match-light for main burners

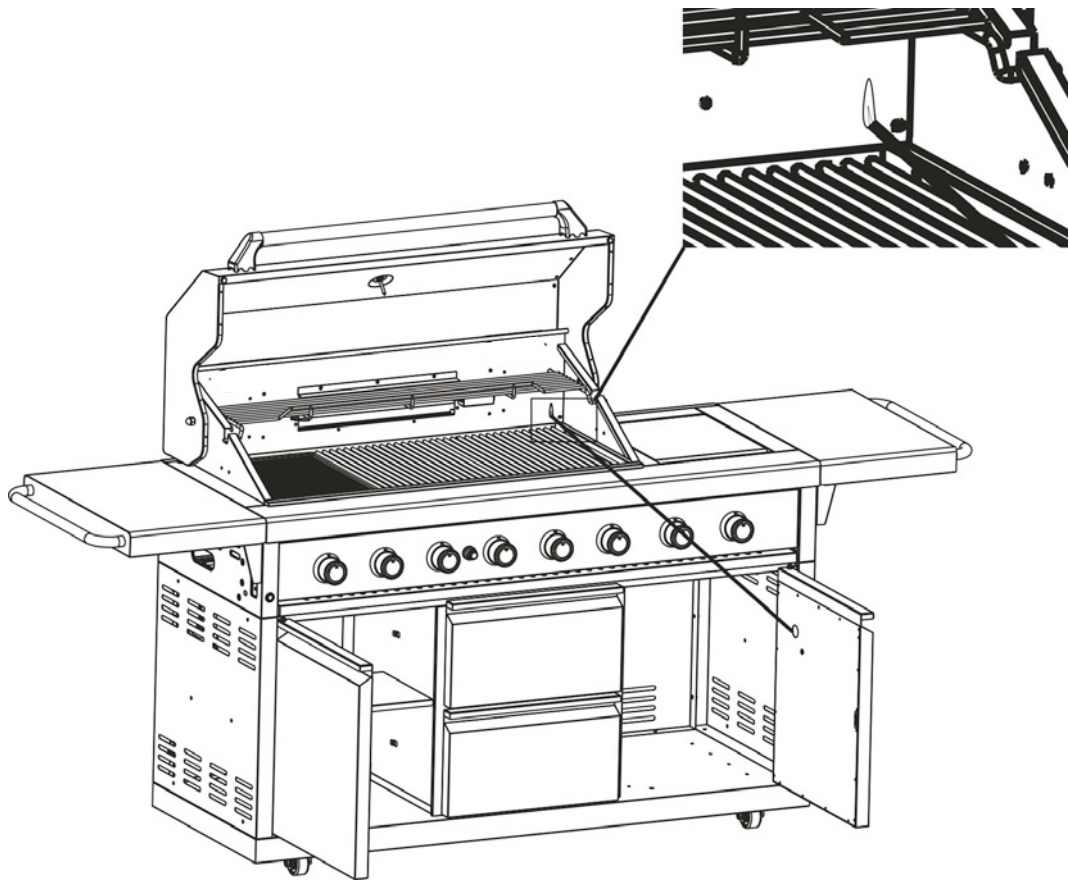

## Way to change the control knob LED lighting



Because the LED lighting is insert into the control knob seat and they are one unit, if the LED need to be replaced, it need to change the whole unit.

1. Take off the control knob from the knob seat like photo shows

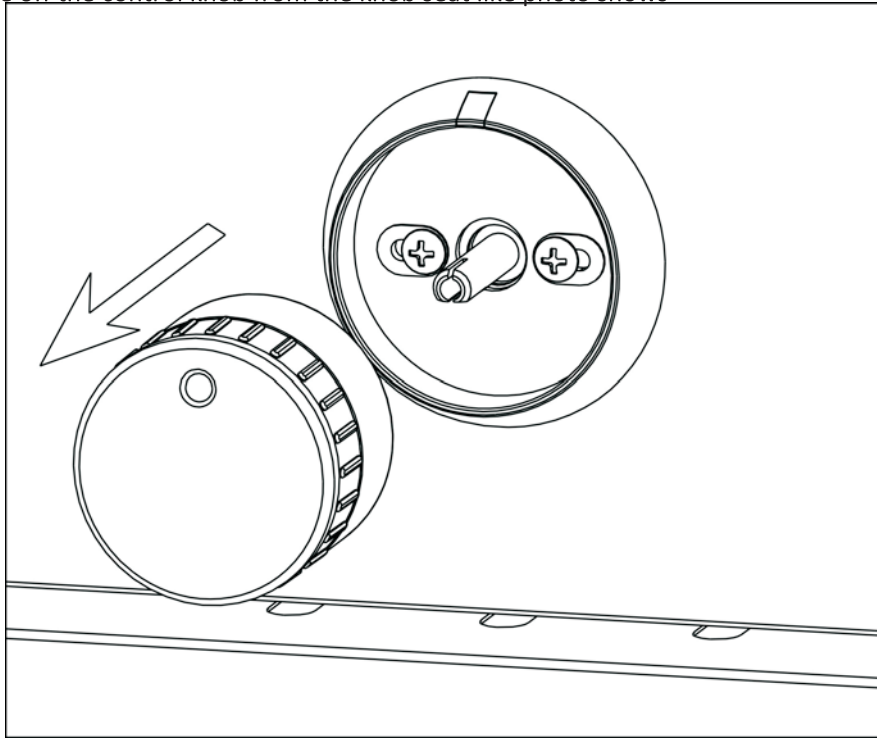

2. Take off the screws like photo shows

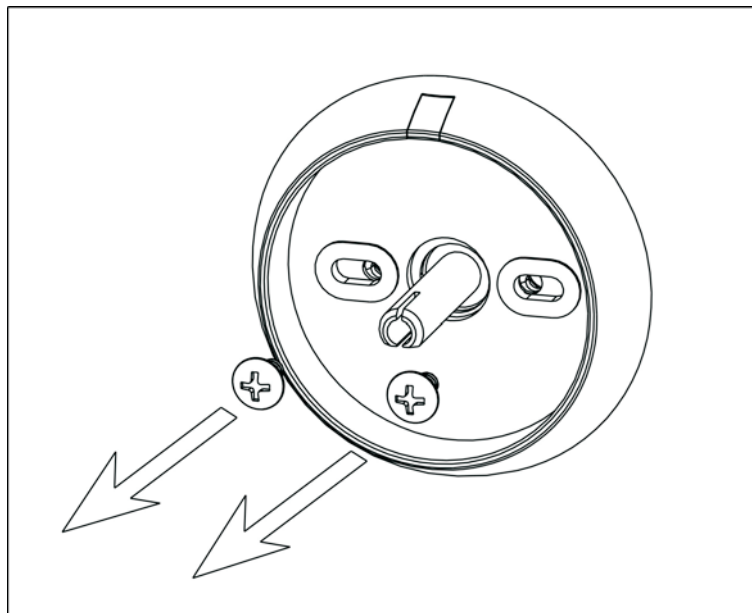

3. Pull out the control knob seat and LED unit carefully

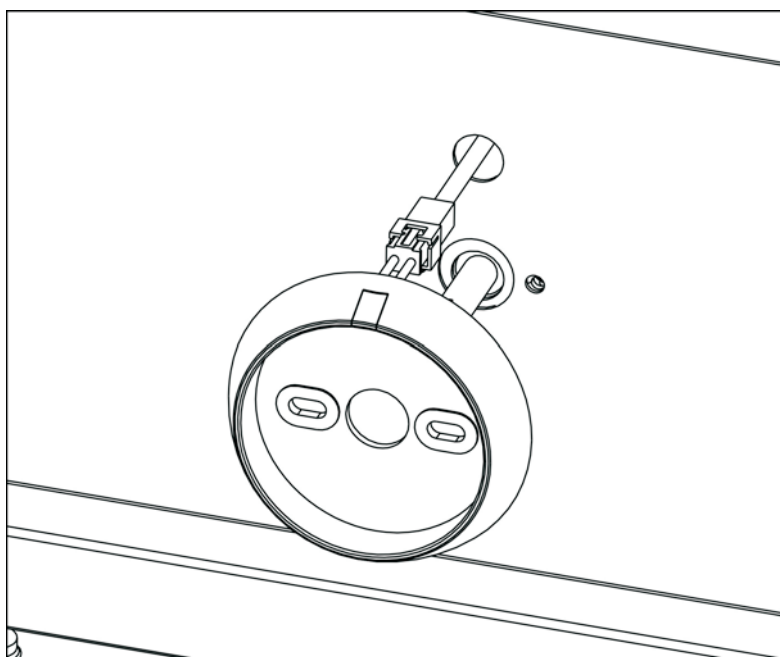



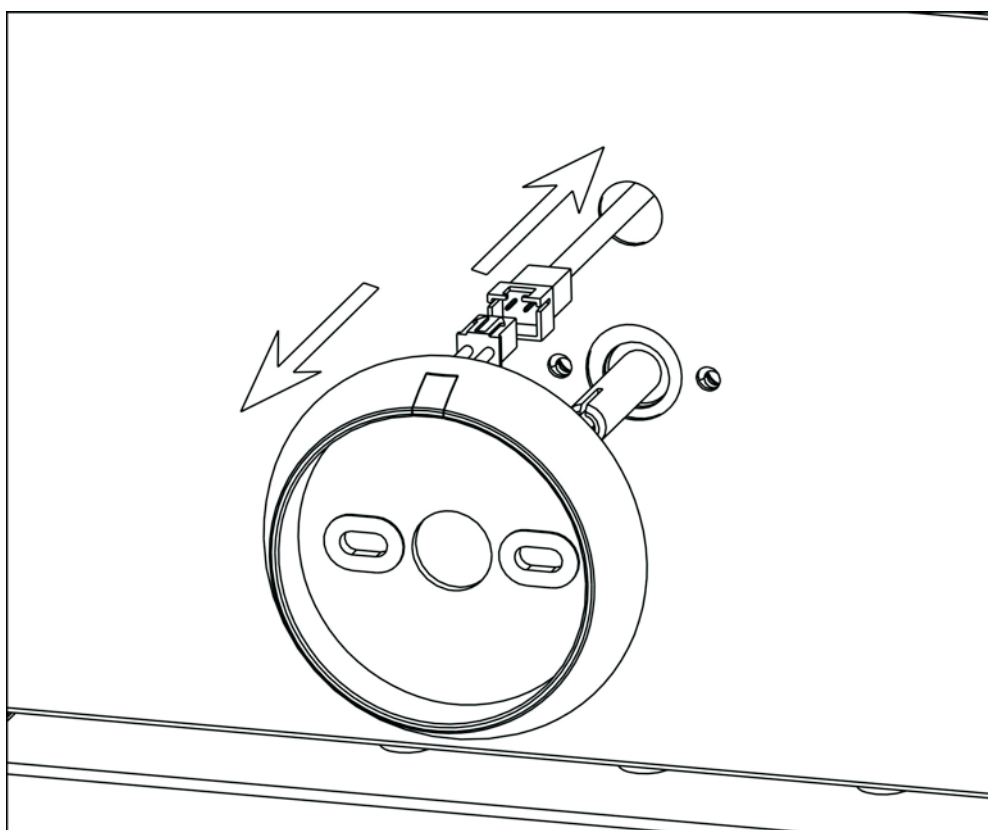



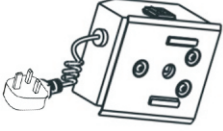

Take off the connection like photo shows, then replace the new unit.

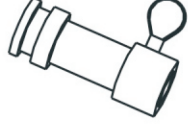

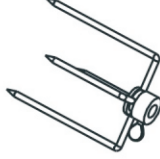
**Assemble the rotisserie kit:**

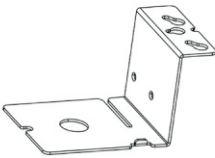
**1) Contents:**

<p>A. AC Motor / DCMotor</p> 	<p>D. Spit Rod collar×1</p> 	<p>G. Collar ×1</p> 	<p>I. Handle ×1</p> 
<p>B. Bolt and Nut×2</p> 	<p>E.4-Sprong Meat Fork×2</p> 	<p>H. Weight Balance ×1</p> 	
<p>C. Motor Bracket ×1</p> 	<p>F. Spit Rod ×1</p> 	<p>J. Washer×2</p> 	

**2) Assemble the motor bracket with the screws and nuts:**

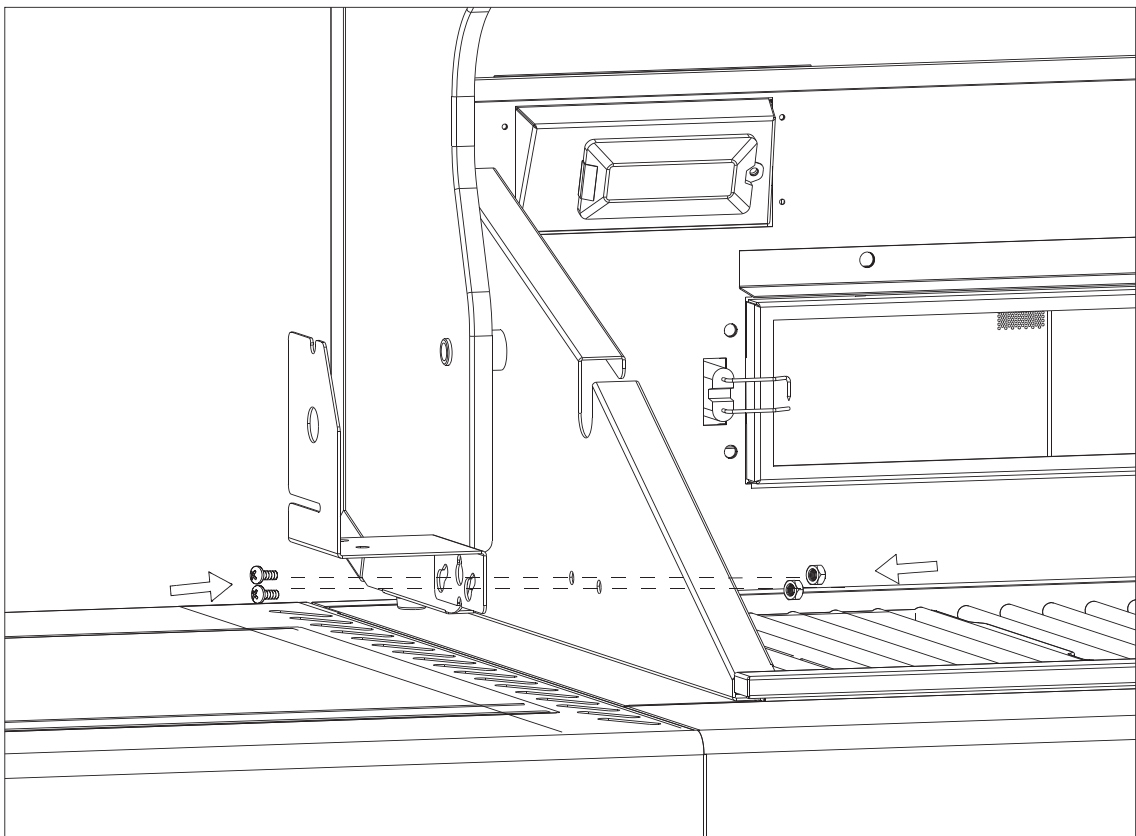

**3) Slide the motor over the bracket**

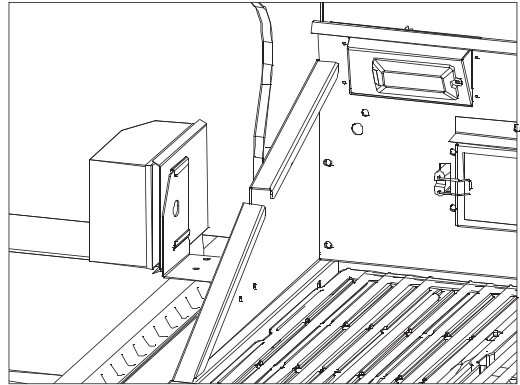
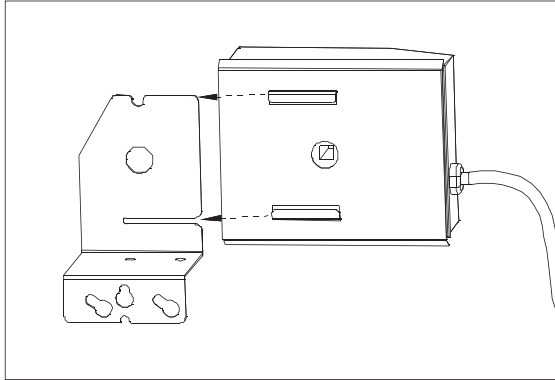

or

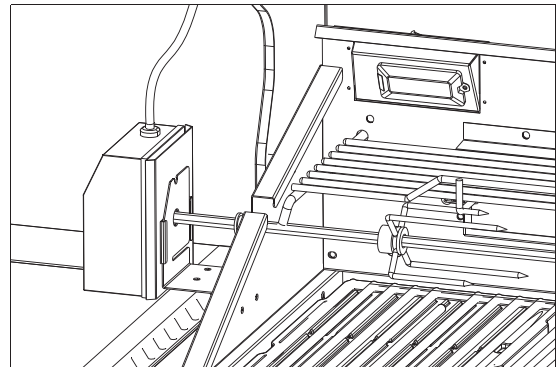
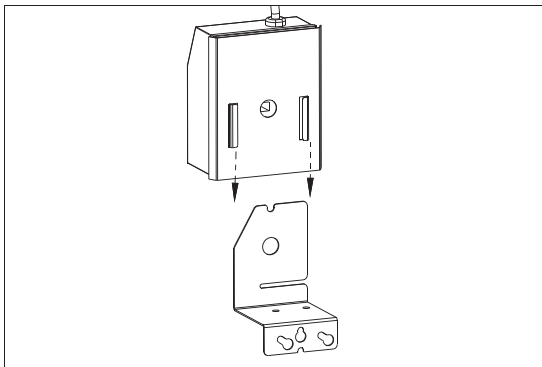

**4) Assemble the forks, nuts, and weight balance onto the pole, and then put the rotisserie pole on the fire box.**

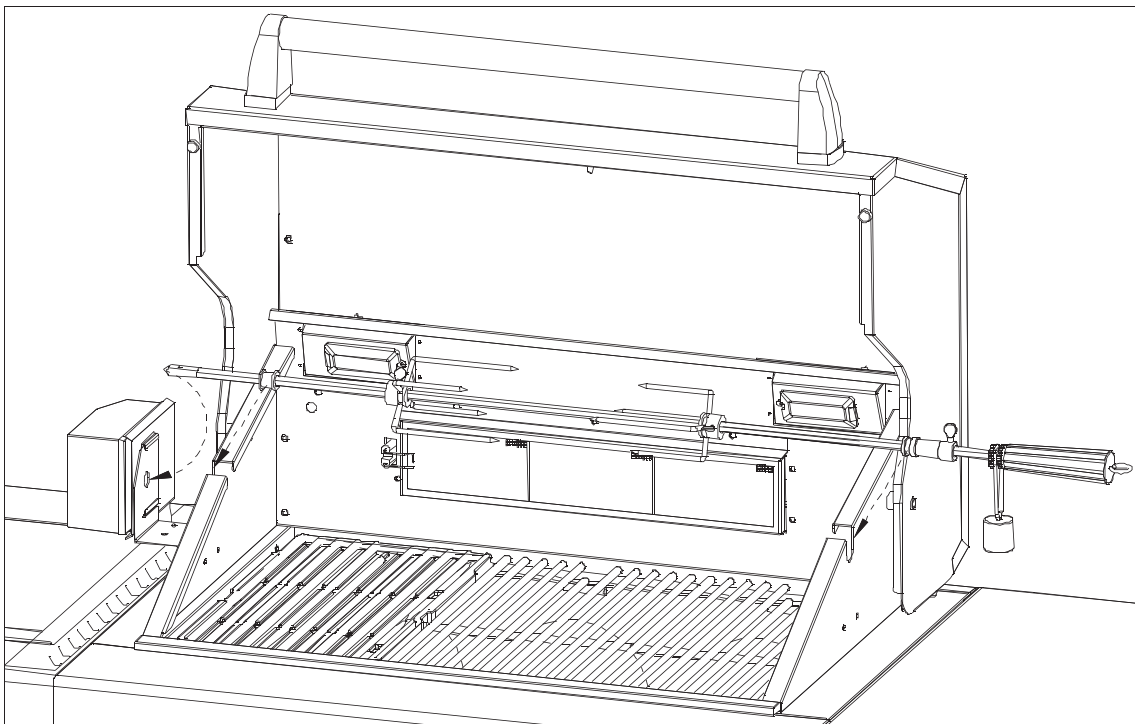

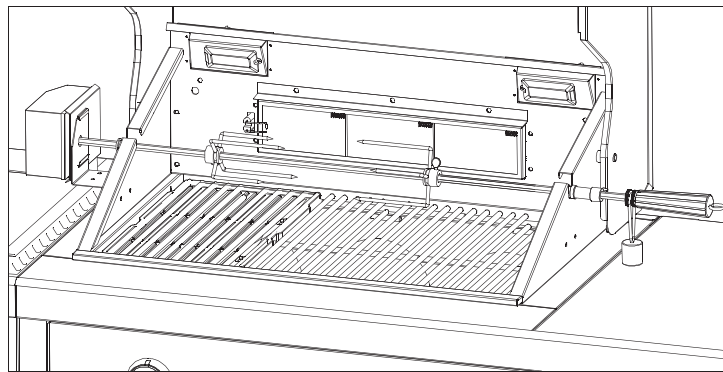
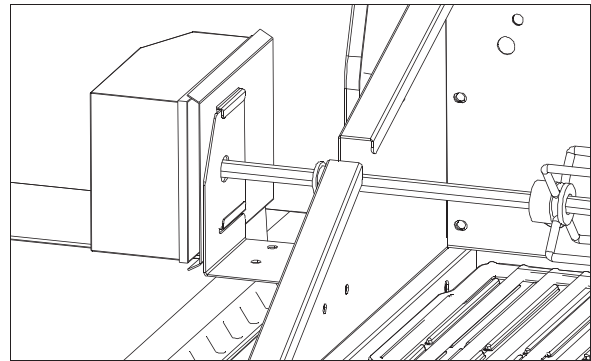
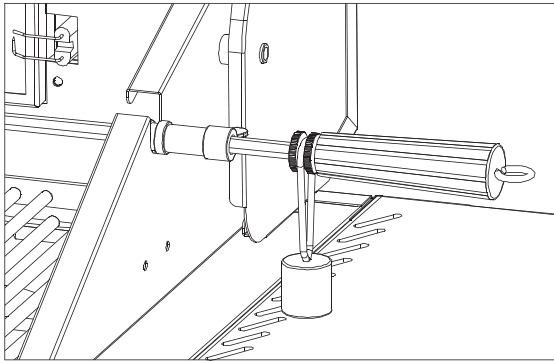

### **5) Using the Rotisserie burner.**

(Also see your grill instruction manual.)

Plug the unit into an electrical outlet. Slide one of the meat prongs onto the rod (prongs toward the food). Centre the food to be cooked on the rod, followed by the thumbscrews. It may also be necessary to wrap food with string, (never use nylon or plastic string) to secure loose portions.

Once the food is secure, insert the pointed end of the rotisserie rod into the motor assembly and rest the other end on the support on the right hand side of the grill. If needed remove the cooking grates for more room.

Turn the power switch to the "ON" Position to start the rotisserie motor.

Notes: When using the rotisserie burner, make sure all main burners are off.

When using the rotisseries burner, it is not recommended to use side burners as injury may result from burning.

### **6) CARE AND MAINTENANCE.**

Turn off, unplug and remove the rotisserie kits when not in use. After using, clean all metal parts using a dry cloth to avoid rusting. Do not immerse any parts in water. Store in a cool, dry place.

### **7) TROUBLESHOOTING**

If the rod is not rotating at a constant speed, reposition the meat on the forks and rod to adjust the weight so that it is balanced. The rod also can be balanced by adjusting the Counterweight.

## Technical info

### Orifice Chart

The different burner valves in this grill have different BTU ratings. The holes in the orifices themselves are drilled to different sizes so as to allow the proper amount of gas to flow through them. Please note the chart below to give an easy reference for the various orifice opening sizes for the different valves in the grill.

Orifice Sizes and BTU Ratings		
	LP	
Components	Orifice Size	BTU
Main burner	1.00	11000
Side burner	1.04	12000
Rear burner	1.04	12000

Extreme care should be taken when removing a burner. It must be correctly centered on the orifice before any attempt is made to relight the grill. Frequency of cleaning will depend on how often you use the grill.

Failure to properly place the burner over the orifice could cause a fire to occur behind and beneath the valve panel, thereby damaging the grill and making it unsafe to operate.

Before cleaning, make sure the gas supply and control knobs are in the "OFF" position and the burners have cooled.

To remove the main burners for cleaning:

1. Locate the burner screw at the rear of the firebox.
2. Remove the screw and lift the burner out of the firebox.

To clean the grill burners:

1. Clean the exterior of the burner with a wire brush. Use a metal scraper for stubborn stains or debris.
2. Clear clogged ports with a straightened paper clip. Never use a wooden toothpick as it may break off and clog the port.
3. Check and clean burners / venturi tubes for insects and insect nests. A clogged tube can lead to a fire beneath, and behind the main control panel.

To reinstall the main burners:

1. Insert the burner over the main burner gas valve
2. Make sure the orifice spud is inside the burner venturi
3. Align the burner screw hole with the firebox hole, insert screw and tighten.



### CAUTION

1. Keep outdoor cooking gas appliance area clear and free from combustible materials, gasoline and other flammable vapors and liquids.
2. Do not obstruct the flow of combustible and ventilation air.
3. Keep the ventilation opening(s) of the enclosure free and clear from debris.

### Flame Characteristics

Check for proper burner flame characteristics. Burner flames should be blue and stable with no yellow tips, excessive noise, or lifting as shown in Fig. 26. The following steps should be followed for correcting the flame characteristics:

1. Turn the control knobs and Liquid Propane cylinder valves "OFF."
2. Allow the grill and burners to cool.
3. If the flame is yellow (not enough air), turn the adjustment screw found at the front of the burner counterclockwise.
4. If the flame is noisy or lifts away from the burner (too much air), turn the adjustment screw clockwise.

## INSTALLATION INSTRUCTIONS

---

### GAS HOOK-UP

Only the pressure regulator and hose assembly supplied with the grill should be used. Any replacement pressure regulator and hose assembly must be specified by the grill manufacturer.

This grill is configured for Liquid Propane. Do not use a Natural Gas supply.

Total gas consumption (per hour) with all burners set on "HI":

Main burners	66,000 BTU/Hr.
Rear burner	12,000 BTU/Hr.
<u>Side burner</u>	<u>12,000 BTU/Hr.</u>
Total	90,000 BTU/Hr.

The installation of this appliance must conform with local codes or, in the absence of local codes, with either the National Fuel Gas Code, ANSI Z223.1/NFPA 54, National Gas Propane Installation Code, CSA B149.2.

Installation in Canada must be in accordance with the Standard CAN/CGA-B149.2 (installation code for gas burning appliances and equipment) and local codes.

### LIQUID PROPANE CYLINDER REQUIREMENTS (20-lb Cylinder)

---

A dented or rusty Liquid Propane cylinder may be hazardous and should be checked by your supplier. Never use a cylinder with a damaged valve. The Liquid Propane cylinder must be constructed and marked in accordance with the specifications for Liquid Propane cylinders by the United States Department of Transportation (DOT) or the National Standard of Canada, CAN/CSA-B339, Cylinders, Spheres and Tubes for Transportation of Dangerous Goods Commission.

The 20-lb cylinder must have a shut off valve terminating in a valve outlet specified, as applicable, for connection type QCC1 in the standard for compressed gas cylinder valve outlet and inlet connection ANSI/CGA-V-1.

Storage of an outdoor cooking gas appliance indoor is permissible only if the cylinder is disconnected and removed from the outdoor cooking gas appliance. The cylinder system must be arranged for vapor withdrawal.

The cylinder must include a collar to protect the cylinder valve.

Manifold pressure: (operating) 10 inches water column (W.C.), (non-operating) 11.2 inches water column(W.C.).

The Liquid Propane cylinder must be fitted with an Overfill Protection Device (OPD).

Remove the plastic valve cover from the Liquid Propane cylinder. Make sure the grill gas hoses do not contact the grease pan or grill firebox when the Liquid Propane cylinder is placed into the cart.

### CONNECTING THE LIQUID PROPANE CYLINDER

---

To connect the Liquid Propane gas supply cylinder:

1. The cylinder valve should be in the "OFF" position. If not, turn the valve clockwise until it stops.
2. Make sure the cylinder valve has the proper type-1 external male thread connections per standard
3. Make sure the burner valves are in the "OFF" position.
4. Inspect the valve connections, port and regulator assembly. Remove debris and inspect the hose for damage.
5. When connecting the regulator assembly to the valve, use your hand to tighten the nut clockwise until it stops. Use of a wrench could damage the quick coupling nut and result in a hazardous situation
6. Open the cylinder valve fully by turning the valve counterclockwise.
7. Before lighting the grill, use a soap and water solution to check all the connections for leaks.
8. If a leak is found, turn the cylinder valve "OFF" and do not use the grill until a local Liquid Propane dealer can make repairs.



#### **WARNING**

Never attempt to use damaged or obstructed equipment. See your local Liquid Propane dealer for repair.

## DISCONNECTING THE LIQUID PROPANE CYLINDER

---

1. Turn the grill burner valves “OFF” and make sure the grill is cool.
2. Turn the Liquid Propane cylinder valve “OFF” by turning clockwise until it stops.
3. Detach the regulator assembly from the cylinder valve by turning the quick coupling nut counterclockwise.
4. Place dust cap on cylinder valve outlet whenever the cylinder is not in use. Only install the type of dust cap on the cylinder valve outlet that is provided with the cylinder valve. Other types of caps or plugs may result in leakage of propane.

## LEAK TESTING

---

### GENERAL

Although gas connections on the grill are leak tested prior to shipment, a complete leak test must be performed at the installation site. Before each use, check all gas connections for leaks using the procedures listed below. If the smell of gas is detected at any time, you should immediately check the entire system for leaks.

### BEFORE TESTING

Make sure all packing materials have been removed from the grill, including the burner tie-down straps.



### WARNING

Check all gas supply fittings for leaks before each use. Do not use the grill until all connections have been checked and do not leak. Do not smoke while leak testing. Never leak test with an open flame.

Make a solution of one part liquid detergent and one part water. You will need a spray bottle, brush, or rag to apply the solution to the fittings. For the initial leak test, make sure the Liquid Propane cylinder is full.

### TO TEST

1. Turn the burner valves off.
2. Turn the Liquid Propane cylinder valve counterclockwise to open the valve.
3. Apply the soap solution to all gas fittings. Soap bubbles will appear where a leak is present.
4. If a leak is present, immediately turn the gas supply “OFF” and tighten leaky fittings.
5. Turn the gas back “ON” and recheck.
6. Should the gas continue to leak from any of the fittings, turn the gas supply “OFF” and contact customer service.
7. If there is evidence of excessive abrasion or wear, or the hose is cut, it must be replaced prior to the outdoor cooking gas appliance being put into operation.

Only those parts recommended by the manufacturer should be used on the grill. Substitutions will void the warranty.

### INSTALLER FINAL CHECK

- Maintain specified clearance of 36 inches from combustible materials and construction.
- All internal packaging has been removed.
- The hose and regulator are properly connected to the Liquid Propane cylinder.
- The unit has been tested and is free of leaks.
- The gas supply shutoff valve has been located.
- All burners are installed.

- Keep the instruction manual for future reference.



**WARNING**

1. Storage of an outdoor cooking gas appliance indoor is permissible only if the cylinder is disconnected and removed from the outdoor cooking gas appliance.
2. Cylinder must be stored outdoors out of the reach of children and must not be stored in a building, garage or any other enclosed area.



**WARNING**

1. Do not store spare Liquid Propane cylinders under or near this appliance.
2. Never fill the cylinder beyond 80 percent capacity.
3. If the information above is not followed exactly, a fire, possibly causing serious injury or death, may occur.



**WARNING**

1. The grill and its individual shutoff valve must be disconnected from the gas supply piping system during any pressure testing of that system at test pressure in excess of 1/2-in. PSI (3.5kpa).

**It is very important to keep your appliance's clear and away from any combustable materials. Maintain at least 36 inches of clearances from sides and back and do not use under overhead combustable construction.**

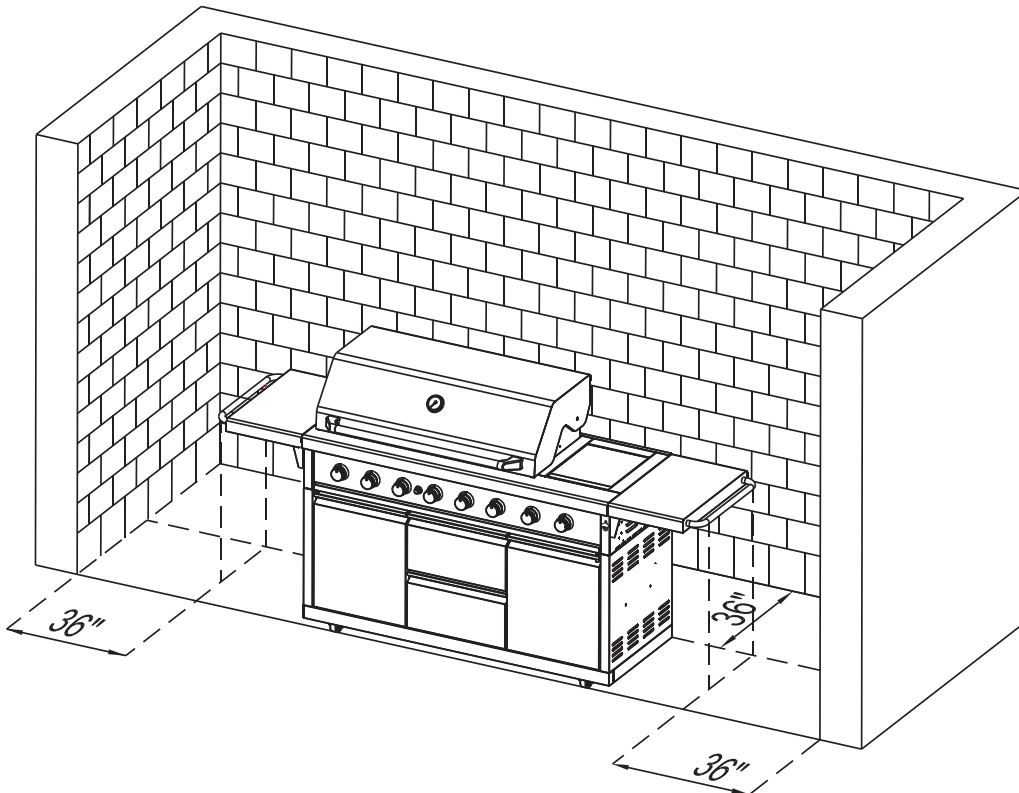

## OPERATING INSTRUCTIONS

---

### General Use of the Grill

Each main burner is rated at 11,000 BTU/Hr. The main grill burners encompass the entire cooking area and are side ported to minimize blockage from falling grease and debris. Above the burners are flame tamers. The igniter knobs are located on the center portion of the valve panel. Each rotary igniter is labeled on the control panel.

### Using the Grill

Grilling requires high heat for searing and proper browning. Most foods are cooked at a “HI” heat setting for their entire cooking time. However, when grilling large pieces of meat or poultry, it may be necessary to turn the heat to a lower setting after the initial browning. This method cooks the food thoroughly without burning the outside.

Food cooked for a long time or basted with a sugar-based marinade may need a lower heat setting near the end of its cooking time.

To begin:

1. Make sure the grill has been leak tested and is properly placed.
2. Remove any remaining packing materials.
3. Light the grill burners using the Lighting Instructions below.
4. Turn the control knob(s) to the “IGNITE / HI” setting, and preheat the grill for 15 minutes. The grill lid should be closed during the pre-heat period.
5. Place the food on the grill and cook to the desired degree of preparation. If necessary, adjust the heat setting. The control knob may be positioned at any setting between “HI” and “LO”.

### Using the Rear Burner

Your grill is capable of performing back burner rotisserie cooking. Light the rear burner as described in the Lighting Instructions on page 20. Once lit, the rear burner will reach cooking temperature in about 1 minute. Rotisserie kits are sold as accessory items. Please follow the rotisserie kit directions for proper use.

The rotisserie motor must be electrically grounded in accordance with local codes or, in the absence of local codes, with the National Electrical Code, ANSI/NFPA 70.

## Lighting Instructions

---

### Before Lighting

Inspect the gas supply hose prior to turning on the gas. If there is evidence of cuts, wear, or abrasion, it must be replaced prior to use.

Screw the regulator (type QCC1) onto the cylinder, and leak check the hose and regulator connections before operating the grill (See the “Leak Testing” instructions on page 13).

Only the pressure regulator and hose assembly supplied with the unit should be used. Never substitute regulators. If a replacement is necessary, contact customer service for proper replacement.



#### **WARNING**

Do not use the grill if the odor of gas is present.

### TO LIGHT THE MAIN BURNERS

1. Make sure all the knobs are in the “OFF” position, and then turn the Liquid Propane cylinder valve “ON” by slowly turning counterclockwise.

2. Open the lid, push and turn the main burner knob slowly to “IGNITE/HI”, burner should be lit immediately.
3. If burner does not light up after step 2, turn the knob off, wait 5 minutes, and repeat lighting procedure above or light by match.

#### TO LIGHT THE SEARING / REAR BURNER

1. Open the lid, push and turn the Searing or Rear burner knob slowly to IGNITE/ON, hold in until the burner is lit. Once it is lit, continue to press and hold for another 15 seconds to ensure the burner stay lit.
2. If burner does not light up after step 1, turn the knob off, wait 5 minutes, and repeat lighting procedure above or light by match.

#### TO LIGHT THE SIDE BURNER

1. Push and turn Side Burner knob slowly to IGNITE/HI, the burner should be lit immediately..
2. If burner does not light up after step 1, turn the knob off, wait for 5 minutes, and repeat the lighting procedure above or light by match.



#### WARNING

When lighting, keep your face and hands as far away from the grill as possible.



#### CAUTION

When using a match to light the grill make sure touse the attached lighting rod.



#### CAUTION

Remove the warming rack when using a match to light the rotisserie burner.

#### TO MATCH LIGHT THE GRILL

If a burner will not light after several attempts using the control knobs, the burners may be lit with a match.

##### Main Burner

1. If you have already attempted to light the main burner with the igniter, allow 5 minutes for any accumulated gas to dissipate.
2. Insert a match into the lighting rod. Ignite the match and insert through the cooking grids to the burner.
3. Push and turn Main Burner knob slowly to IGNITE/HI, the burner should light immediately.
4. If the burner does not light within seconds turn the knob to the “OFF” position, wait 5 minutes and try again.

##### Searing Main Burner and Rear Burner

1. If you have already attempted to light the searing main burner or Side burner with the igniter, allow 5 minutes for any accumulated gas to dissipate.
2. Insert a match into the lighting. Ignite the match and insert (through the cooking grids) to the burner.
3. Push and turn the Searing or Rear Burner knob slowly to IGNITE/ON. Hold in until the burner is lit. Once it is lit, continue to press and hold for another 15 seconds to ensure the burner stays lit.
4. If the burner does not light within seconds, turn the knob off, wait 5 minutes and try again.

##### Side Burner

**Note:** Remove the warming rack when using a match to light the rear burner.

1. If you have already attempted to light the rear burner with the igniter, allow 5 minutes for any accumulated gas to dissipate.
2. Insert a match into the lighting rod. Ignite the match and hold next to the burner.
3. Push and turn the Side Burner knob slowly to IGNITE/HI. The burner should light immediately.
4. If the burner does not light within seconds turn the knob off, wait 5 minutes and try again.

## CARE AND MAINTENANCE

---

### **Stainless Steel**

There are many stainless steel cleaners available. Always use the mildest cleaning process first, scrubbing in the direction of the grain. Do not use steel wool as it will scratch the surface. To touch up noticeable scratches in the stainless steel, sand very lightly with dry 100 grit sand paper in the direction of the grain.

Grease specks can gather and bake onto the surfaces of the stainless steel, giving the appearance of rust. For removal, use an abrasive pad with a stainless steel cleaner.

### **Cooking Grates**

The easiest way to clean the grill is immediately after cooking is completed and the flames have been turned off. Wear a barbeque mitt to protect your hand from heat and steam.

Scrub the hot cooking grates by dipping a bristled barbeque brush in tap water. Cleaning will be more difficult if the grill is allowed to cool.

### **Grease Pan**

The grease pan should be emptied, wiped down and washed after each use with a mild detergent and warm water solution. Check the grease pan frequently and do not allow excess grease to accumulate and flow out of the grease pan.

### **Searing Main Burner**

Clean the exterior of the burner with a wire brush. Clear any clogged burner ports with a straightened paper clip. Never enlarge the burner ports. Never use a wooden toothpick as it may break off and clog the port.

### **Grill Burners**