

Recommended Maximum Weight

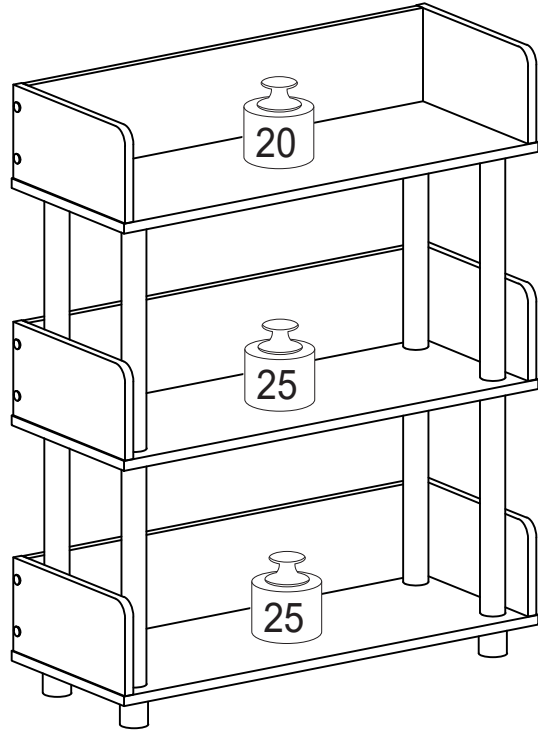

*Unit in Pound(lbs.)

WARNING:

>This unit has been designed to support the maximum loads shown. Exceeding these load limits could cause sagging, instability, product collapse, and/or serious injury.

>DO NOT allow children to climb on unit.

> Put heavier items on lower shelves.

Assembly Instruction

3-TIER DISPLAY RACK

00:20

Approx. 20 minutes





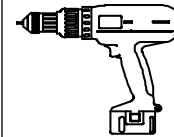

Recomm. 1 Person

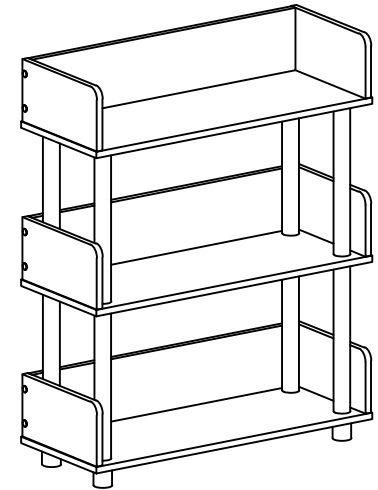

Tools Required

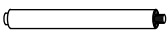

HARDWARE & PARTS LIST

NO	HARDWARE LIST	QTY
1	POLE 	8pcs
2	FASTENER 	27pcs
3	LEG 	4pcs
4	WALL MOUNT SET 	2sets

NO	PARTS LIST	QTY
A	TOP PANEL	1pc
B	SHELF PANEL	2pcs
C	SIDE PANEL	6pcs
D	BACK PANEL	3pcs

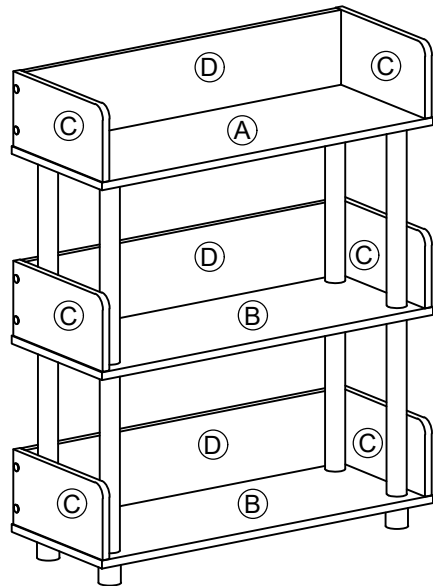







USEFUL HINTS BEFORE YOU START:

1. Read each step carefully before starting.
2. It is important that each step is performed in correct order to avoid difficulties.
3. Identify, sort and count the parts before assembly.
4. Assemble your furniture on packaging cardboard to prevent scratch or damage.
5. Clean the product with mild cleanser using soft damped cloth. Do not use harsh or abrasive cleanser.
6. Using incompatible hardware might cause damage to product.

STEP 7

PLEASE FOLLOW BELOW INSTRUCTION TO PREVENT PRODUCT TIP OVER.

HARDWARE LIST			QTY
			2 Sets
			

WALL

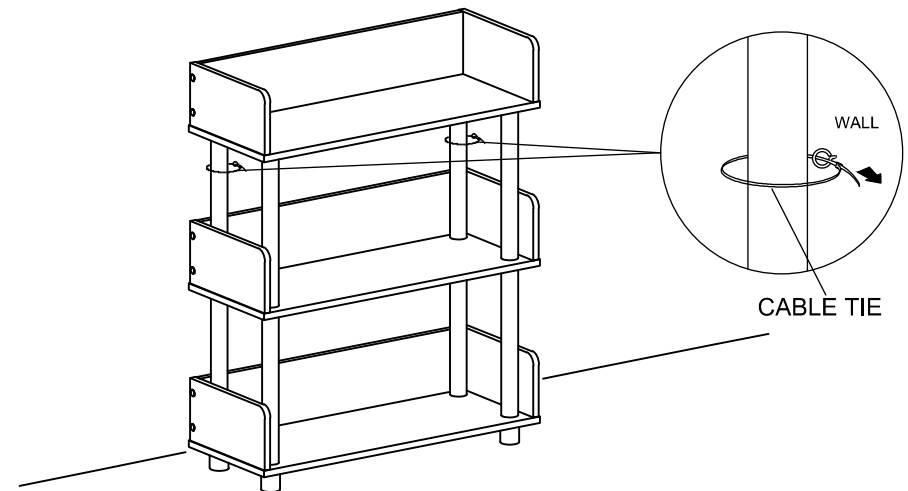

STEP 6

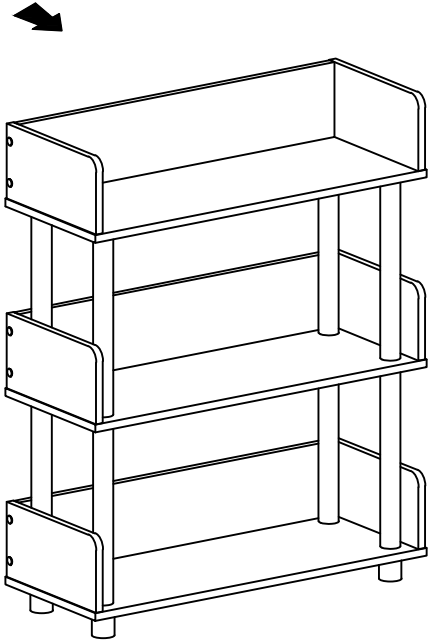
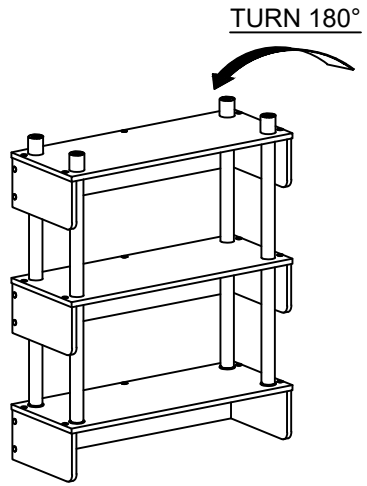

ASSEMBLY INSTRUCTIONS

BEFORE YOU BEGIN, PLEASE READ ASSEMBLY INSTRUCTIONS CAREFULLY,
FOLLOW THEM STEP BY STEP.

STEP 1

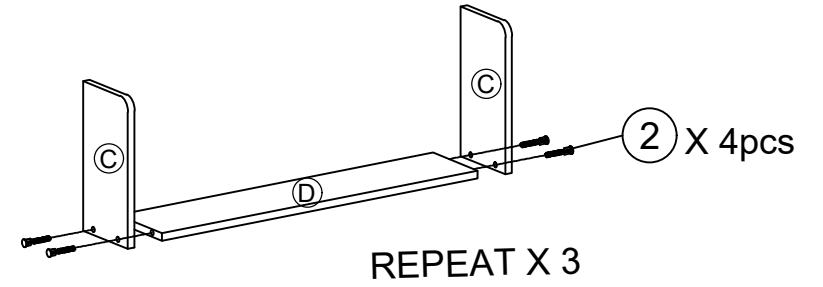

STEP 2

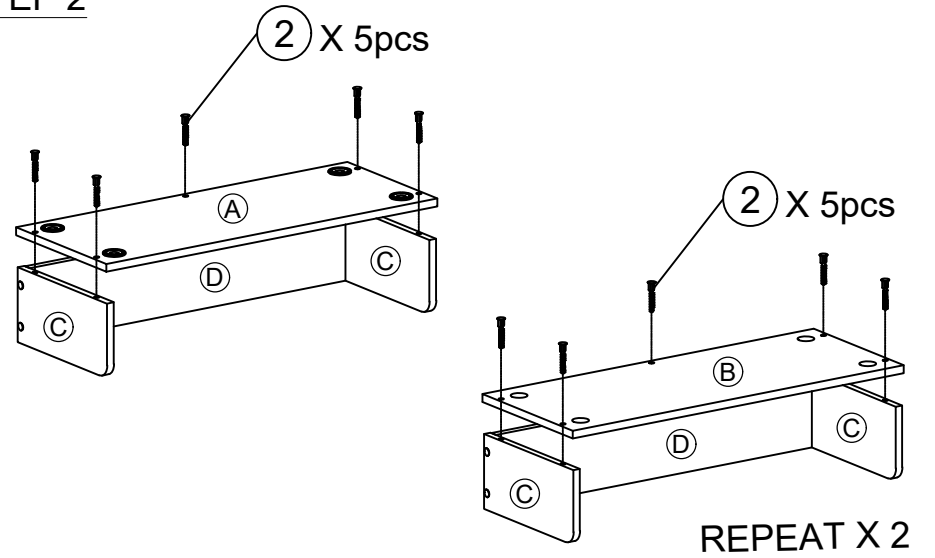

STEP 3

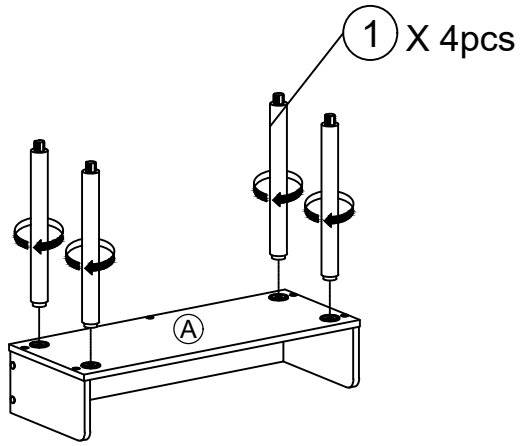

STEP 4

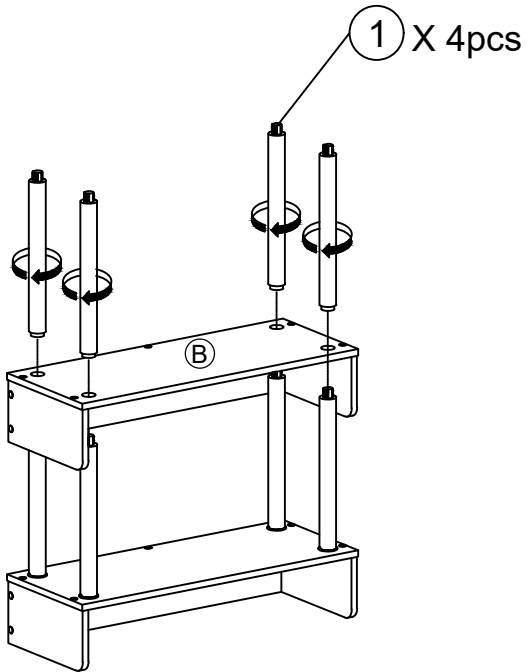

STEP 5

