

Installation & Assembly

Version: 1.0

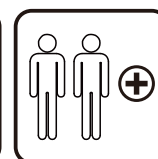

EN_IMPORTANT, RETAIN FOR FUTURE REFERENCE: READ CAREFULLY.

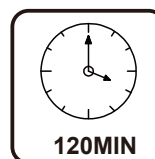
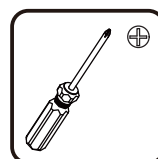
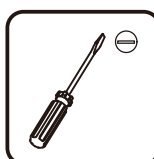
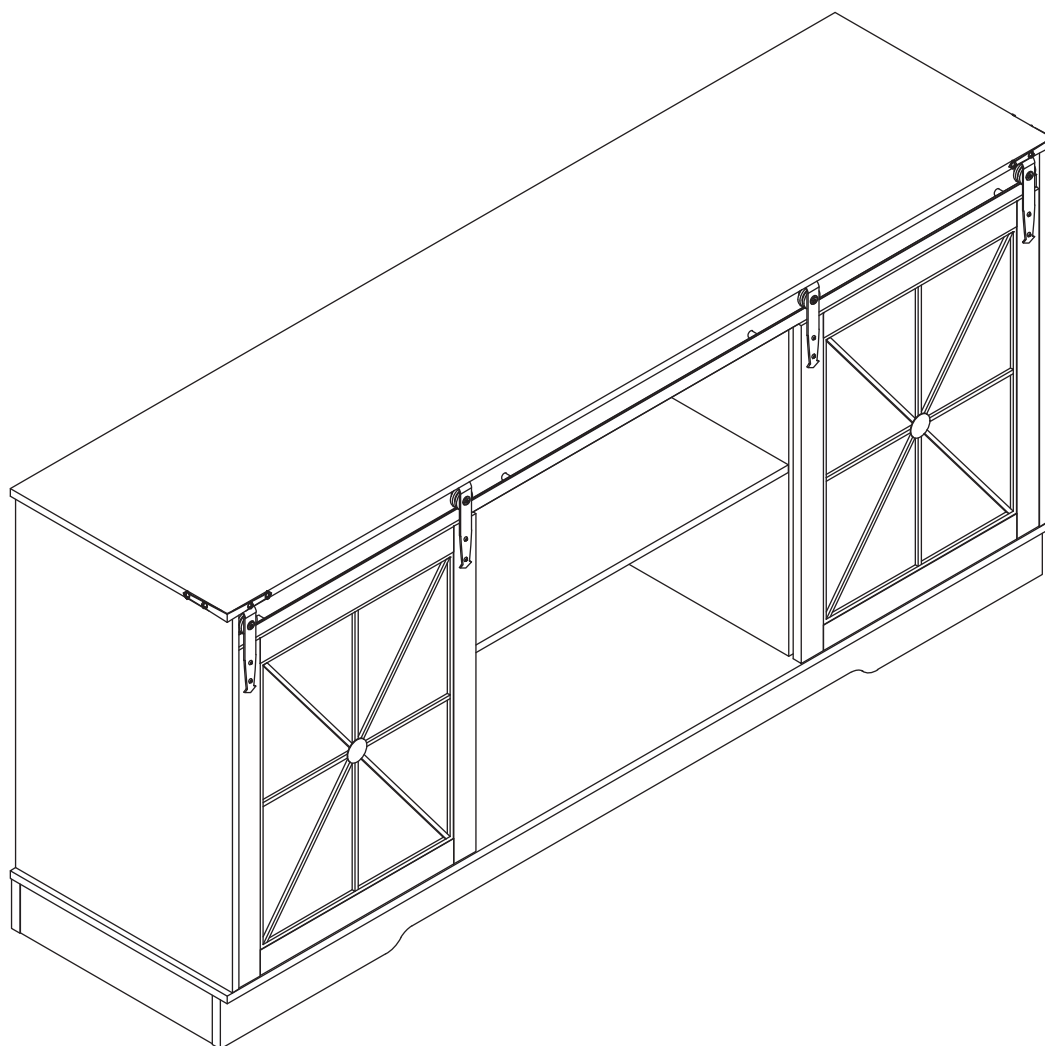
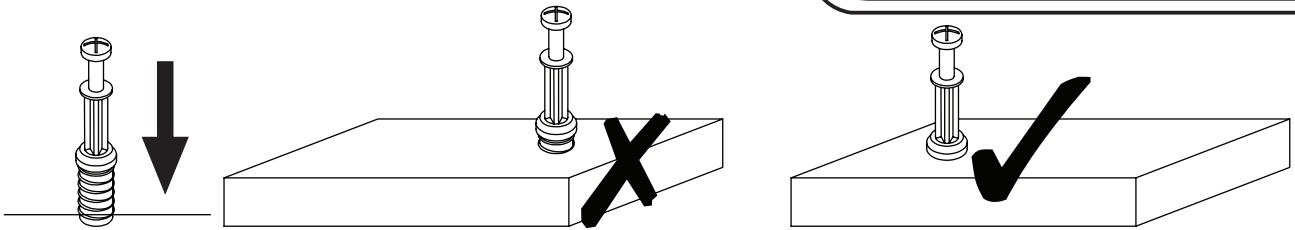

EN_QUICKFIT: Tighten quickfit until shoulder is flush with panel. Do not overtighten or undertighten.

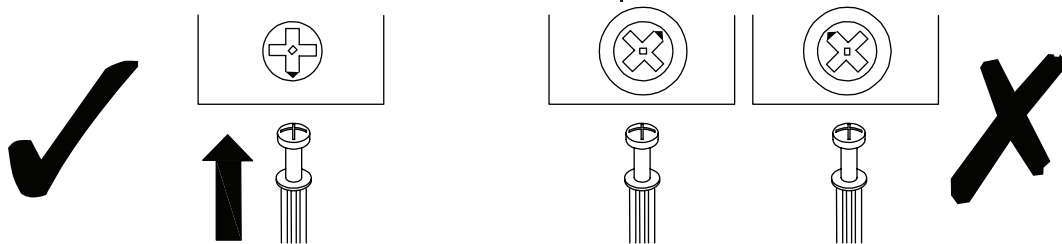

EN_CAM LOCK: When fitting cam lock, ensure starting position is correct before you insert connecting quickfit.

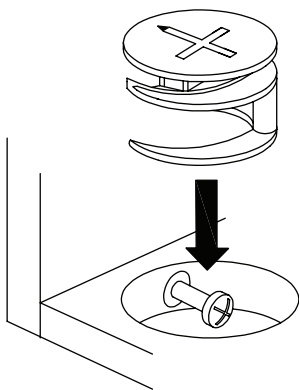



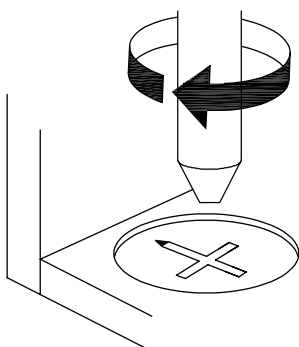

EN_Quickfit head should be in the centre of the cam lock when the two panels are joined.
Cam lock should be inserted before quickfit.

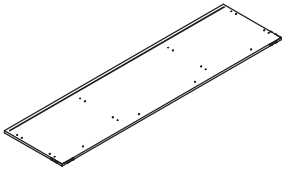
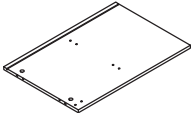
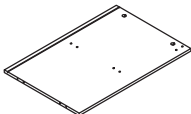
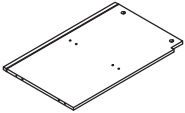
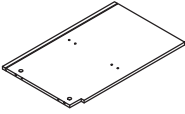
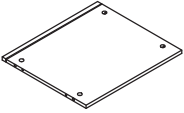
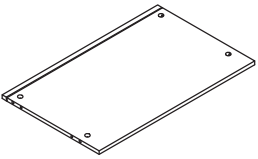
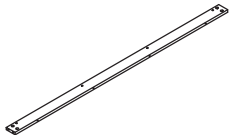
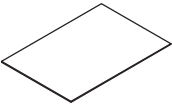
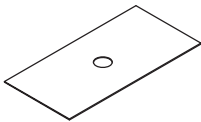

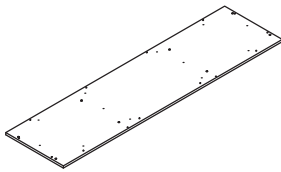
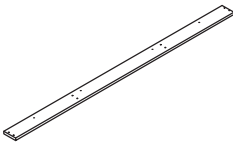
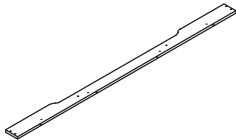
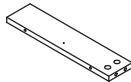
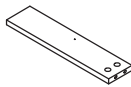
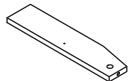
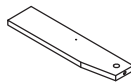
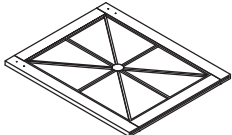
EN_Turn cam lock clockwise to tighten.









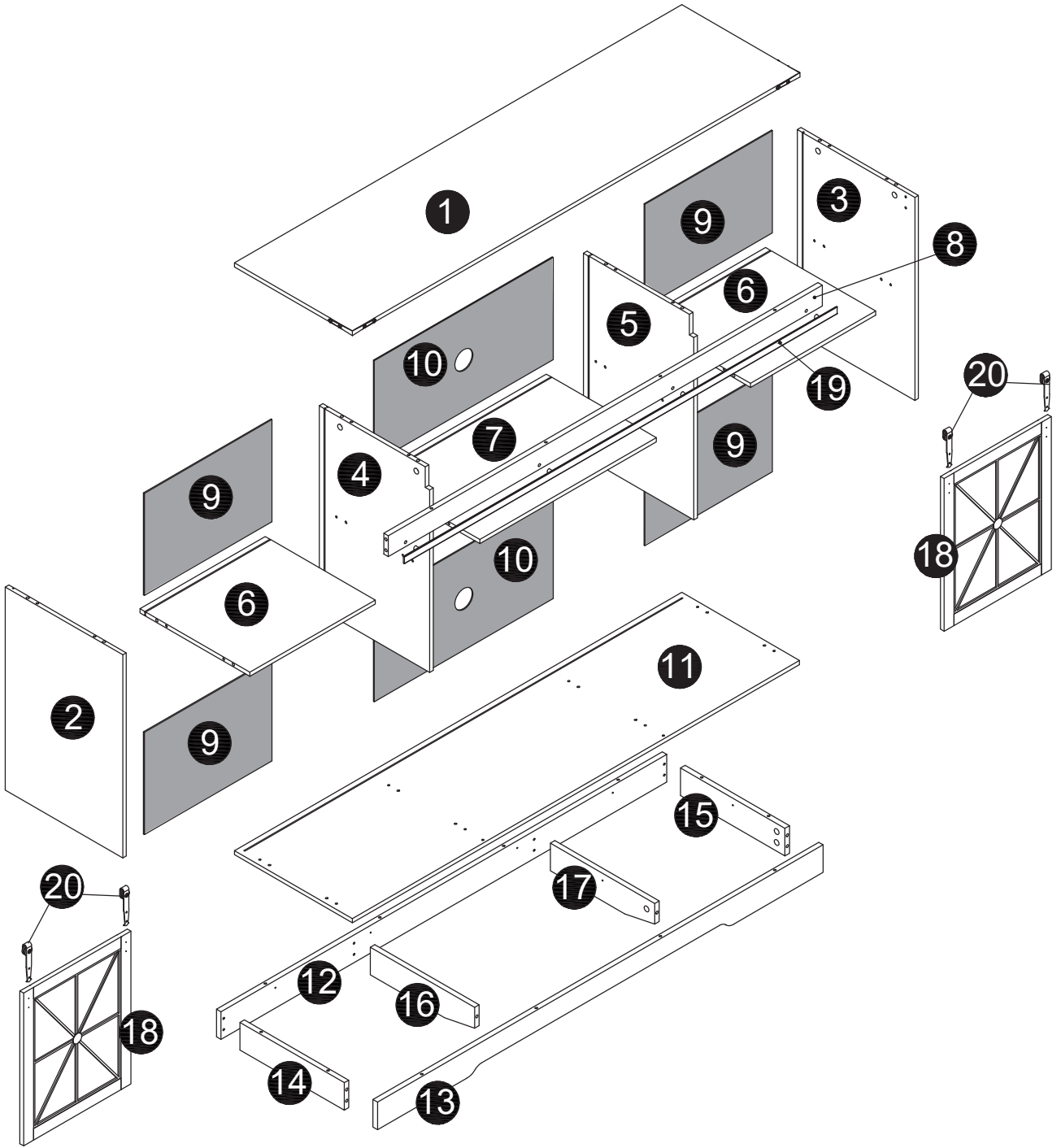

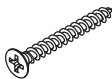

NO.	PARTS	QTY	SPARE
①		x1	
②		x1	
③		x1	
④		x1	
⑤		x1	
⑥		x2	
⑦		x1	
⑧		x1	
⑨		x4	
⑩		x2	

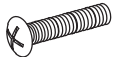
NO.	PARTS	QTY	SPARE
⑪		x1	
⑫		x1	
⑬		x1	
⑭		x1	
⑮		x1	
⑯		x1	
⑰		x1	
⑱		x2	
⑲		x1	
⑳		x4	

NO.	PARTS	QTY	SPARE
	 Hardware Kit		

NO.	PARTS	QTY	SPARE



 <p>A x30 Ø6x35mm +2(spare)</p>	 <p>B x30 Ø15x10mm +2(spare)</p>	 <p>C x44 Ø6x30mm +3(spare)</p>	 <p>D x18 Ø4x35mm +1(spare)</p>	 <p>E x24 Ø3.5x12mm +2(spare)</p>	 <p>F x12</p>
 <p>G x2 Ø4x20mm</p>	 <p>H1</p>  <p>H2 Ø3x16mm +2(spare)</p>	 <p>I x2 Ø6x30mm</p>	 <p>J x2 Ø4x14mm</p>	 <p>K x2</p>	 <p>L x4 Ø6x25mm</p>
 <p>M x8 Ø4x14mm</p>					

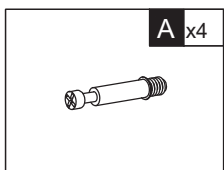

01

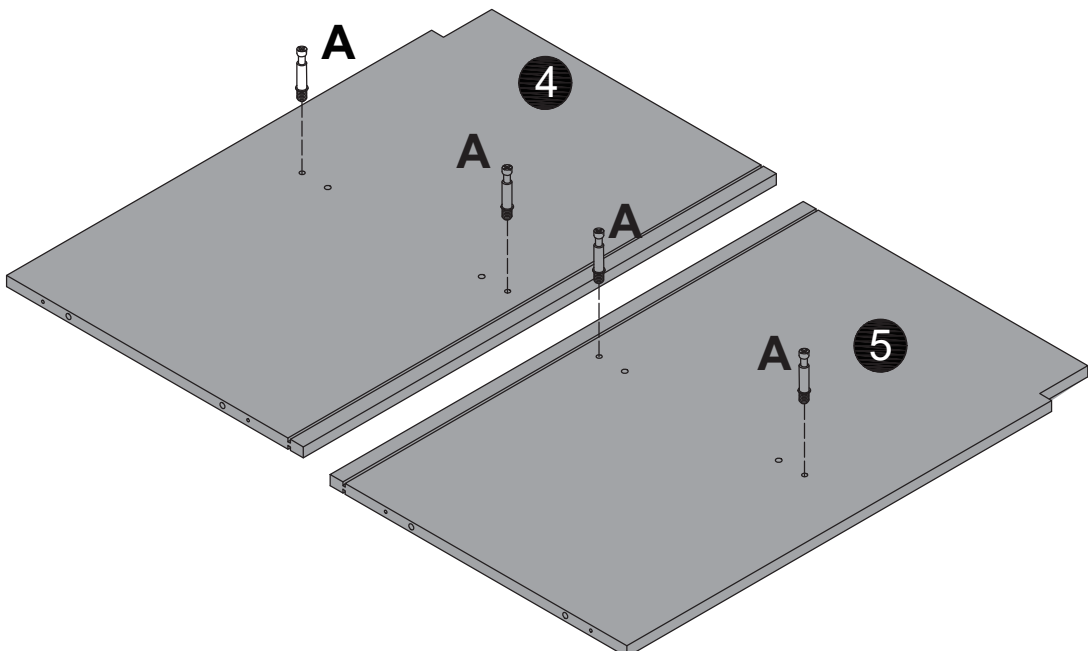

B x4



C x4

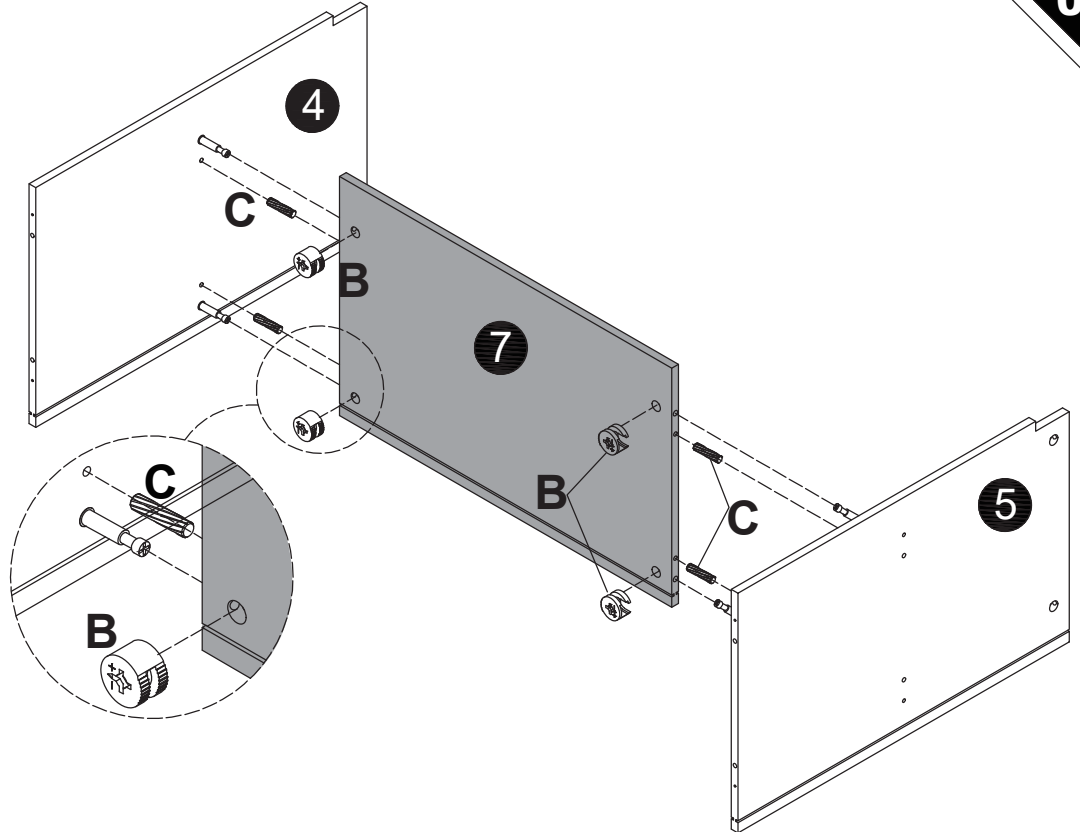

A x4

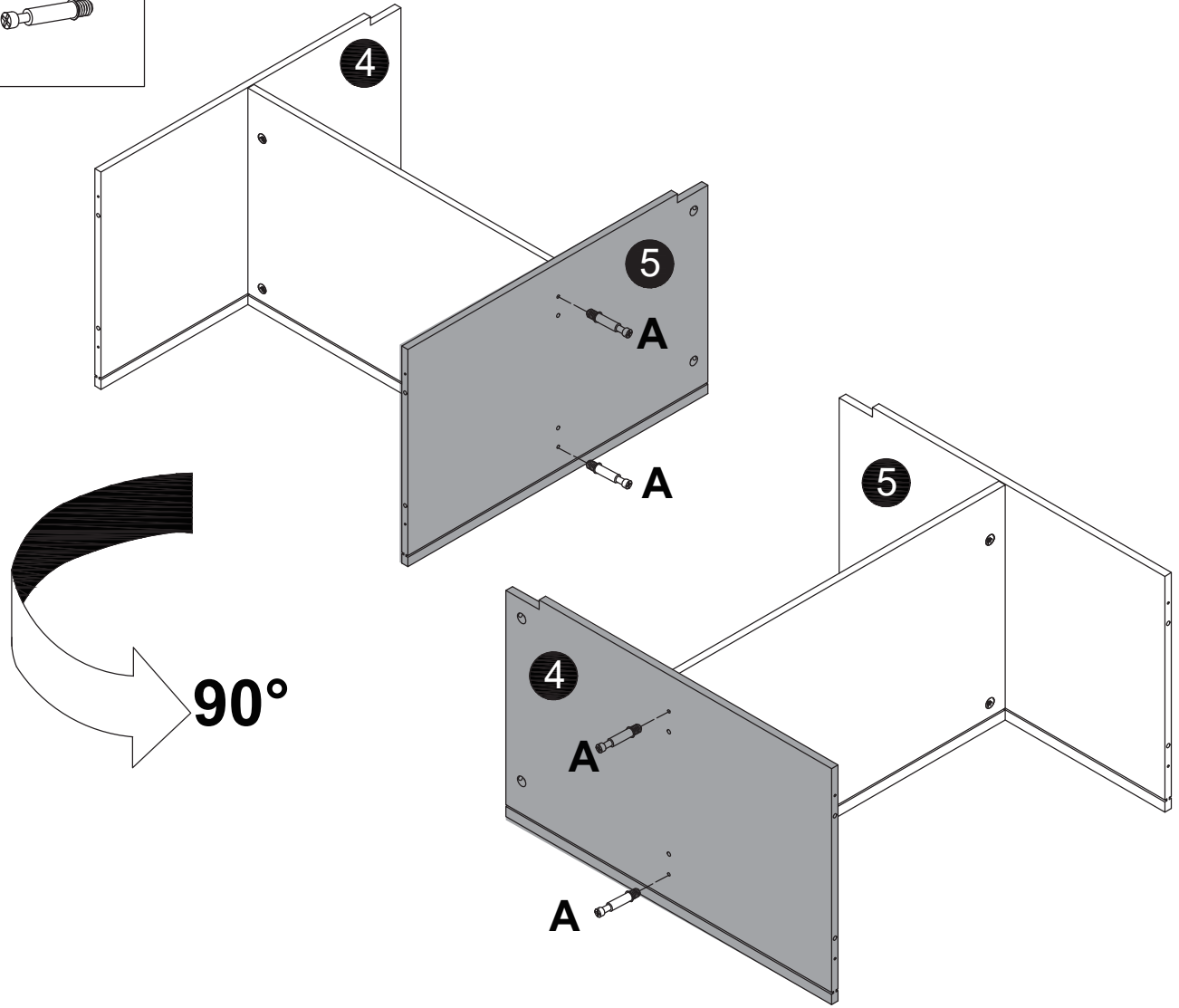
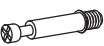

B x4

C x4

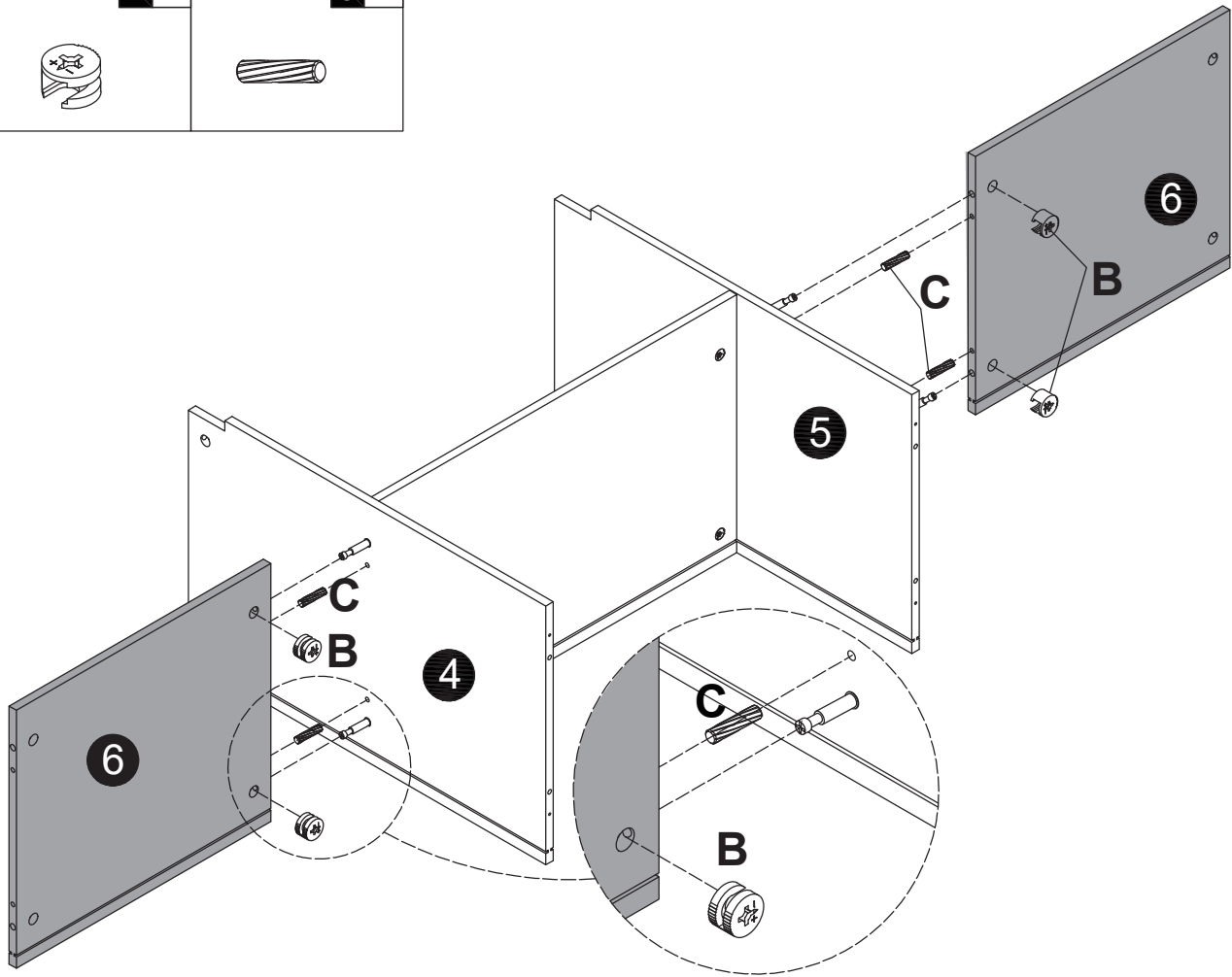

A x8

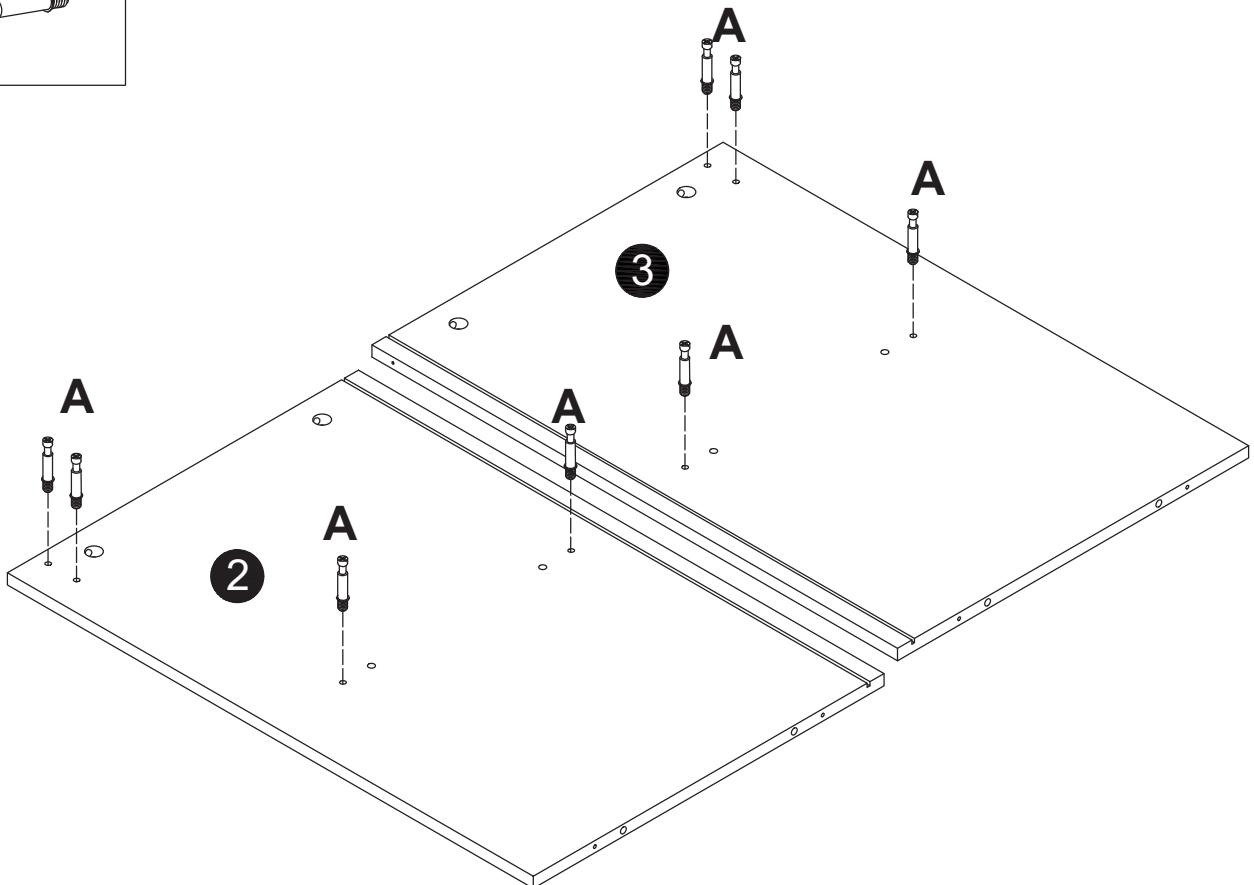
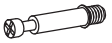

B x2

C x2

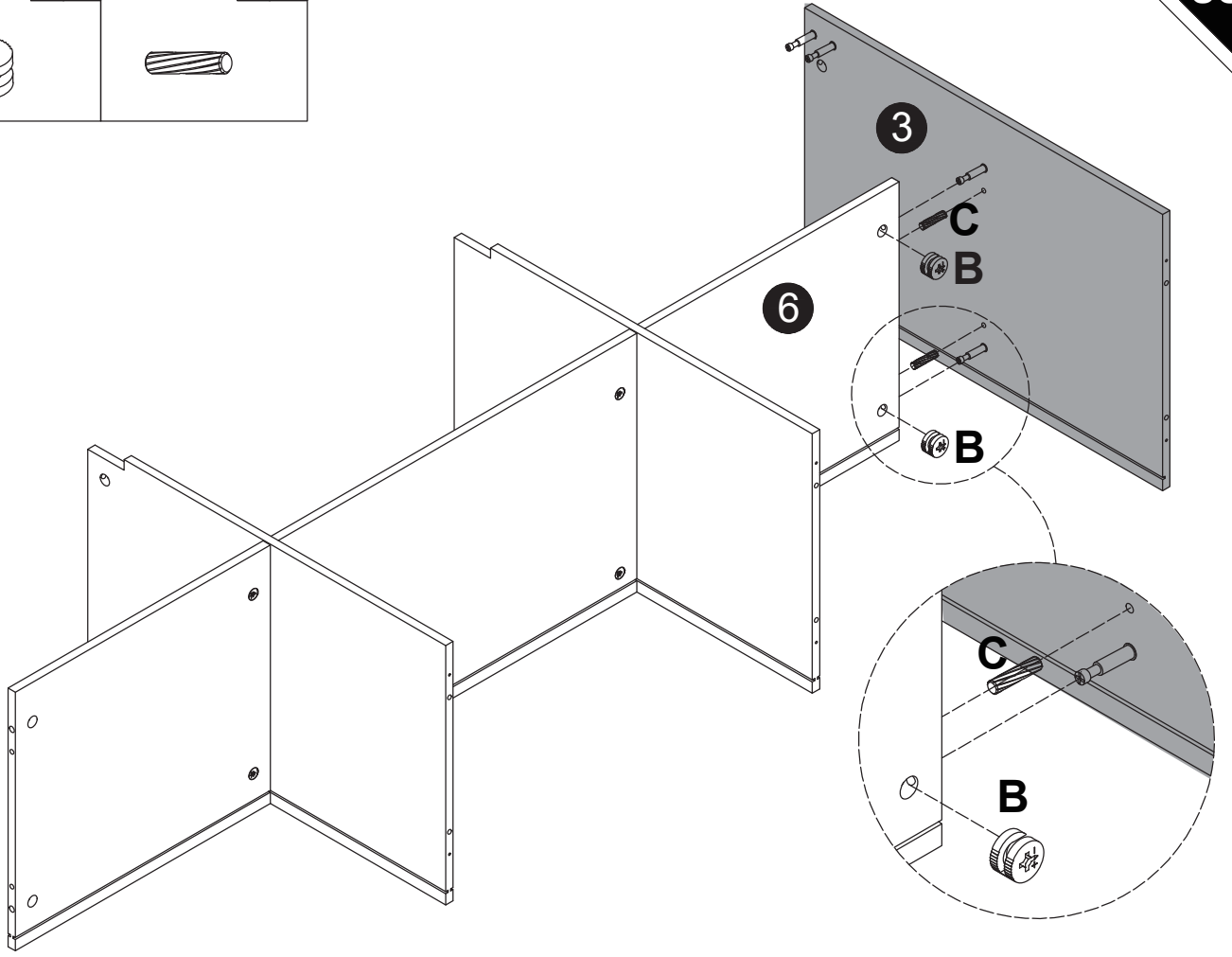

B x2

C x2

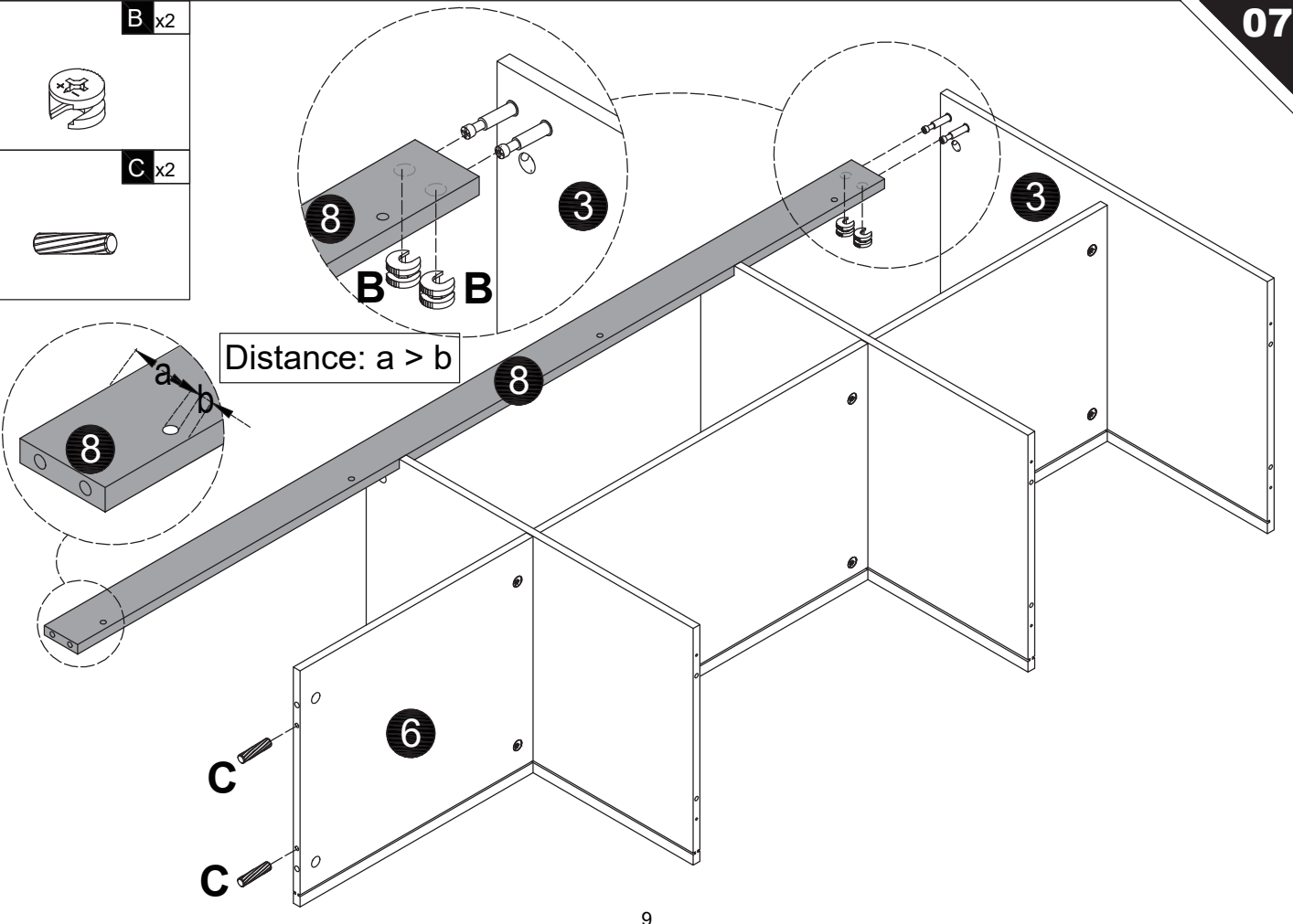

B x4

08

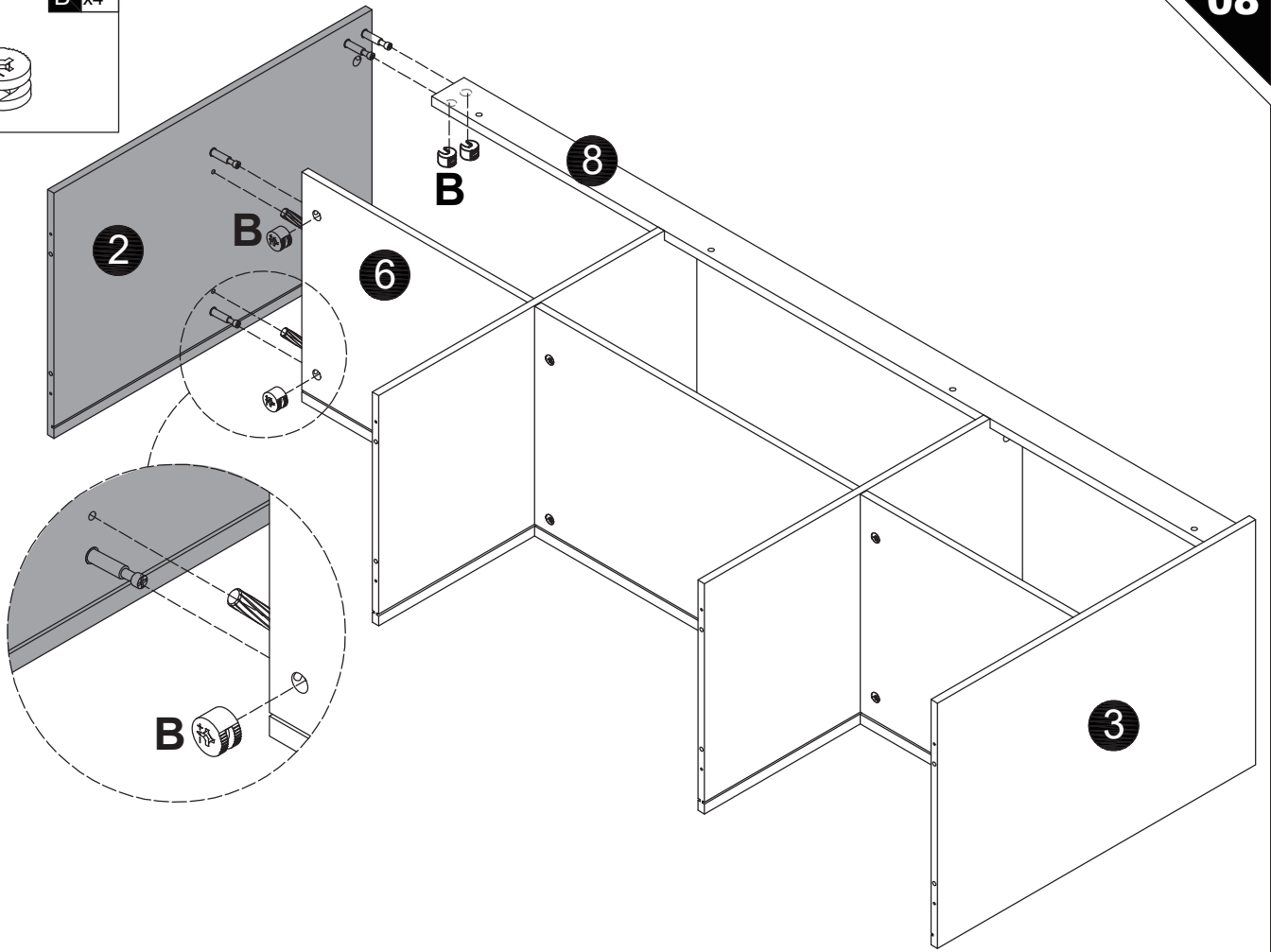

L x4

09

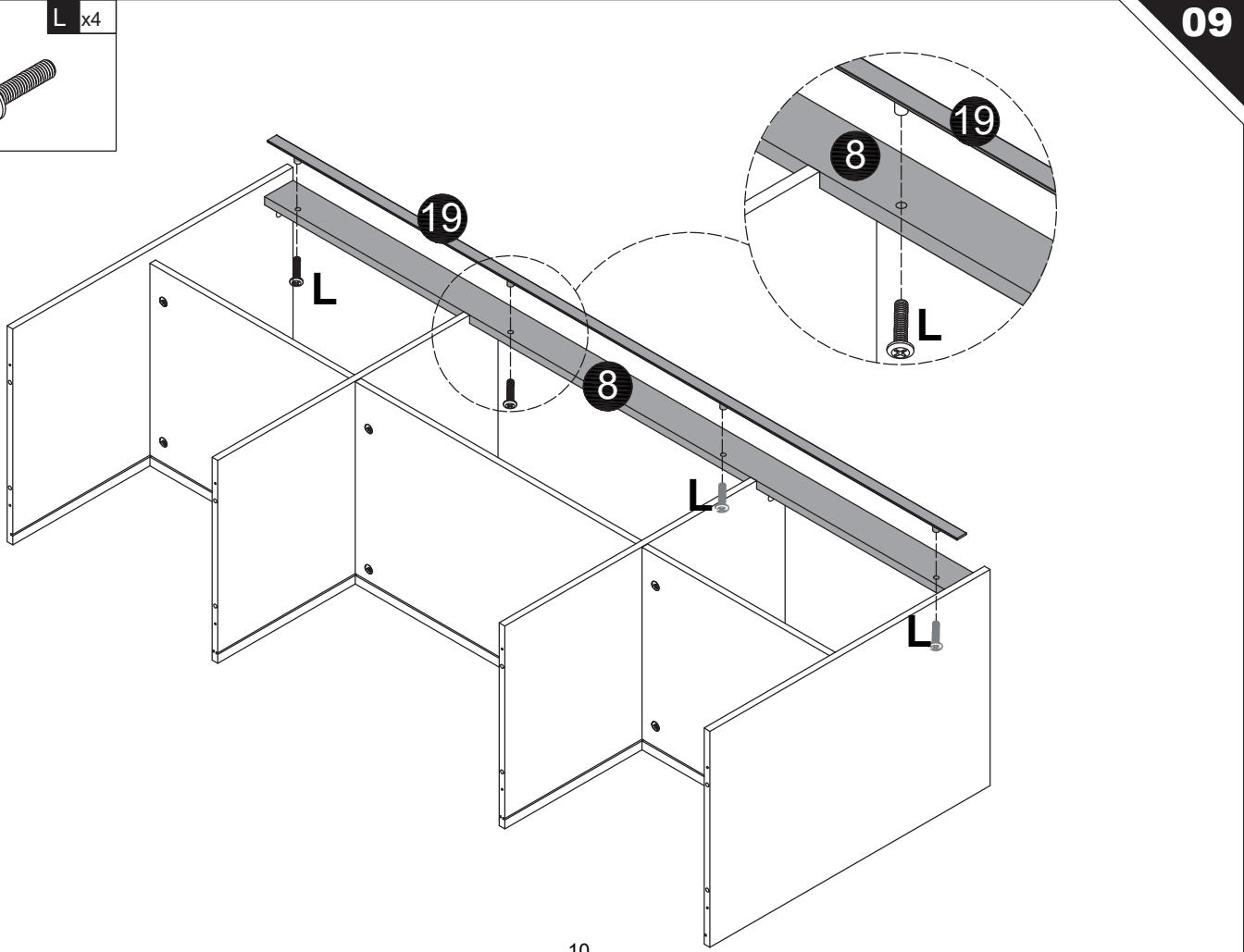

C x8

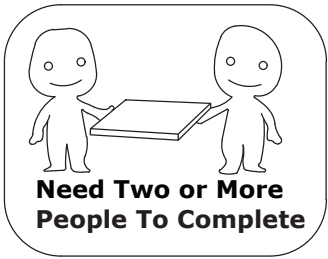

Need Two or More People To Complete

10

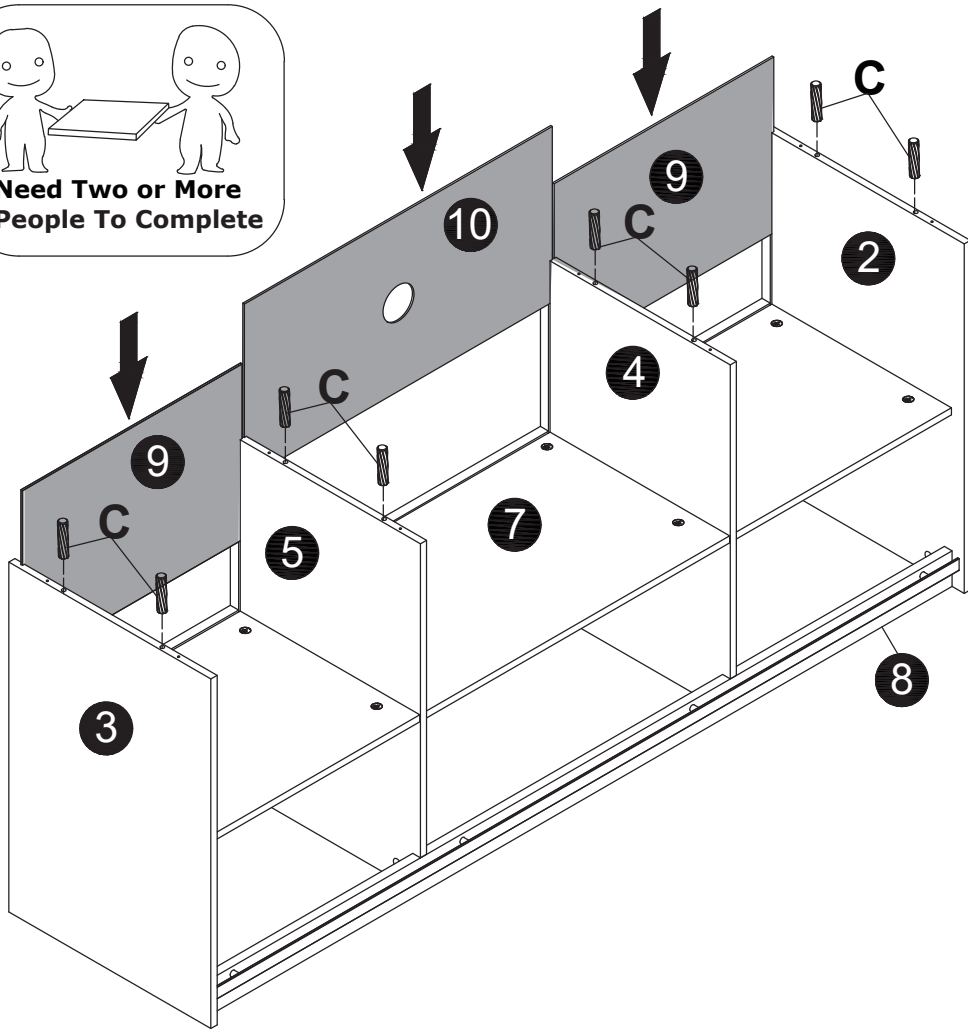

D x8

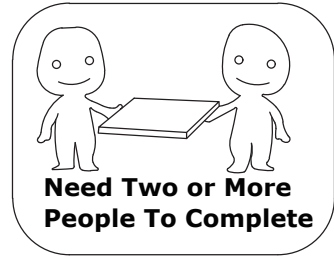

Need Two or More People To Complete

11

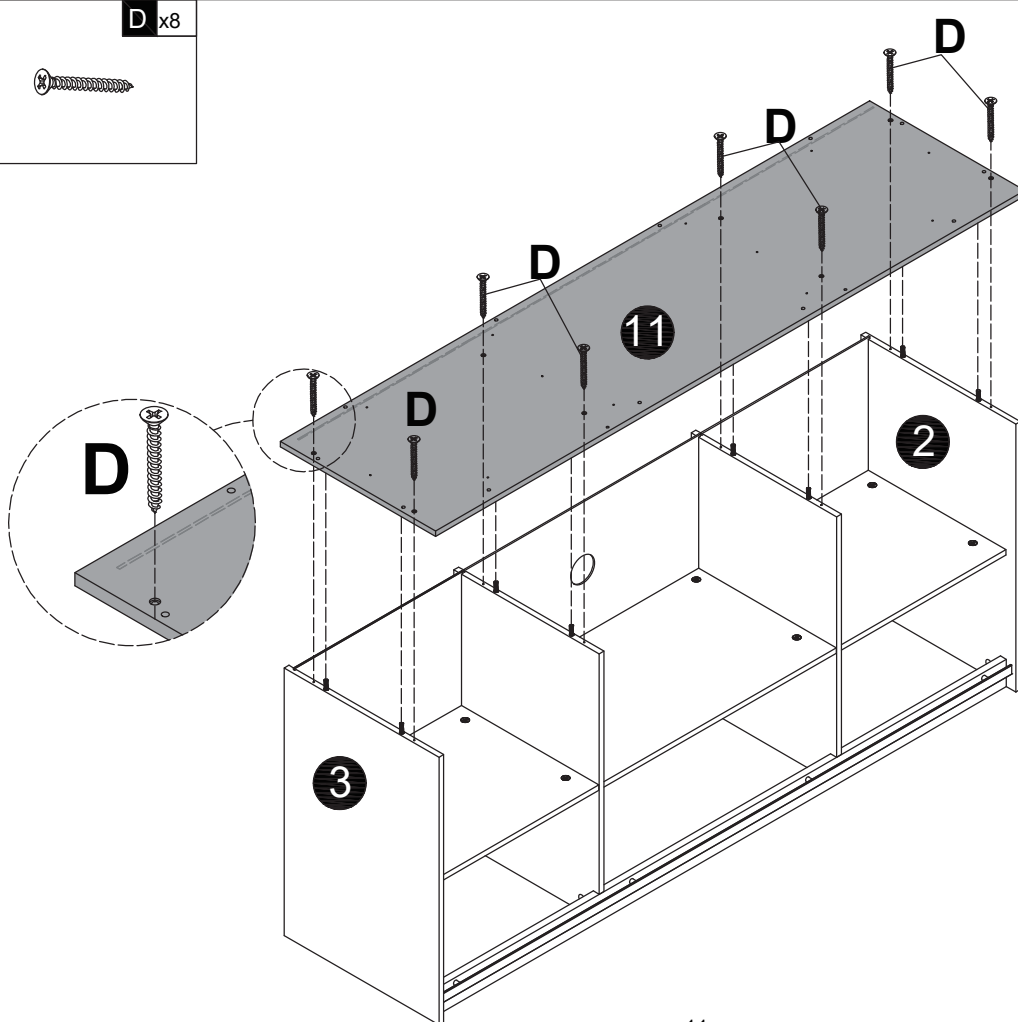

G x2

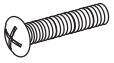

12

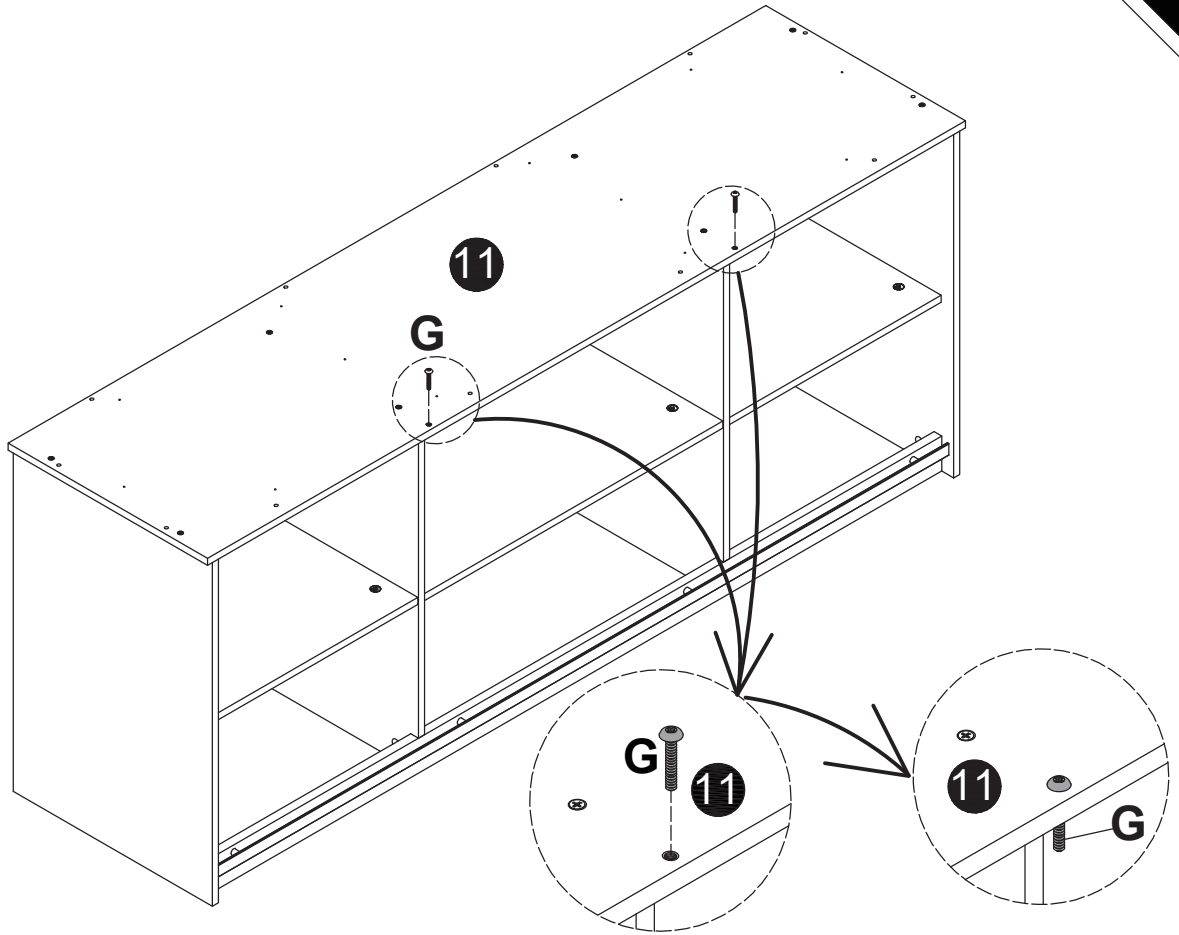

A x6

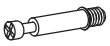

E x8



F x8



13

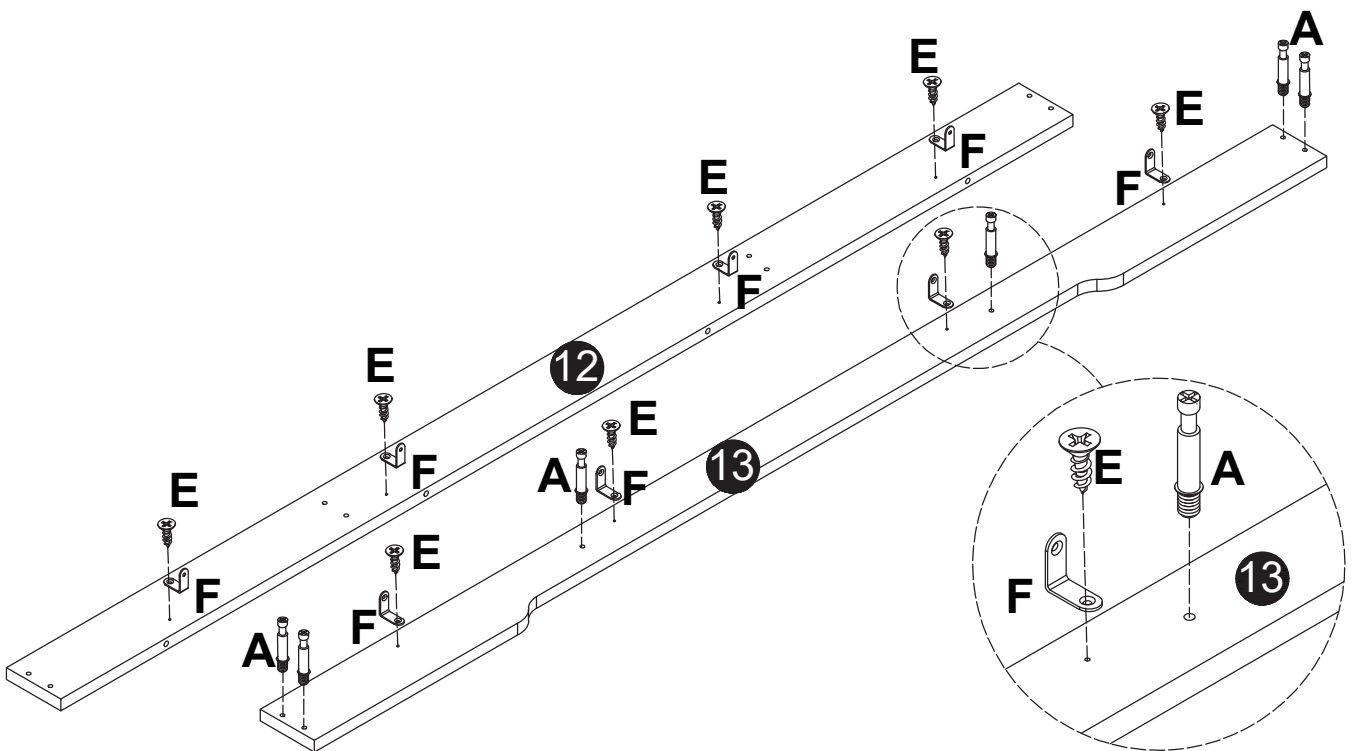

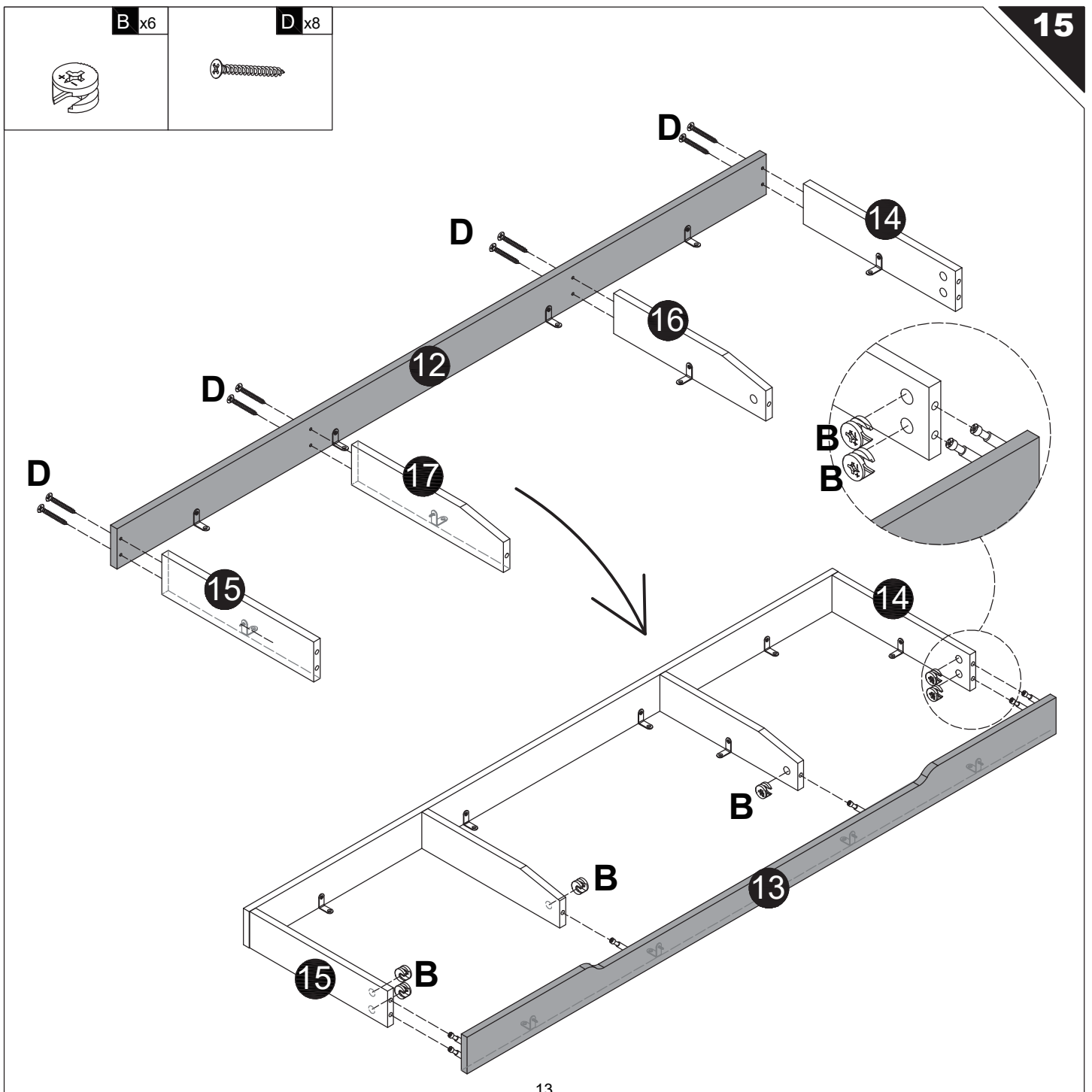
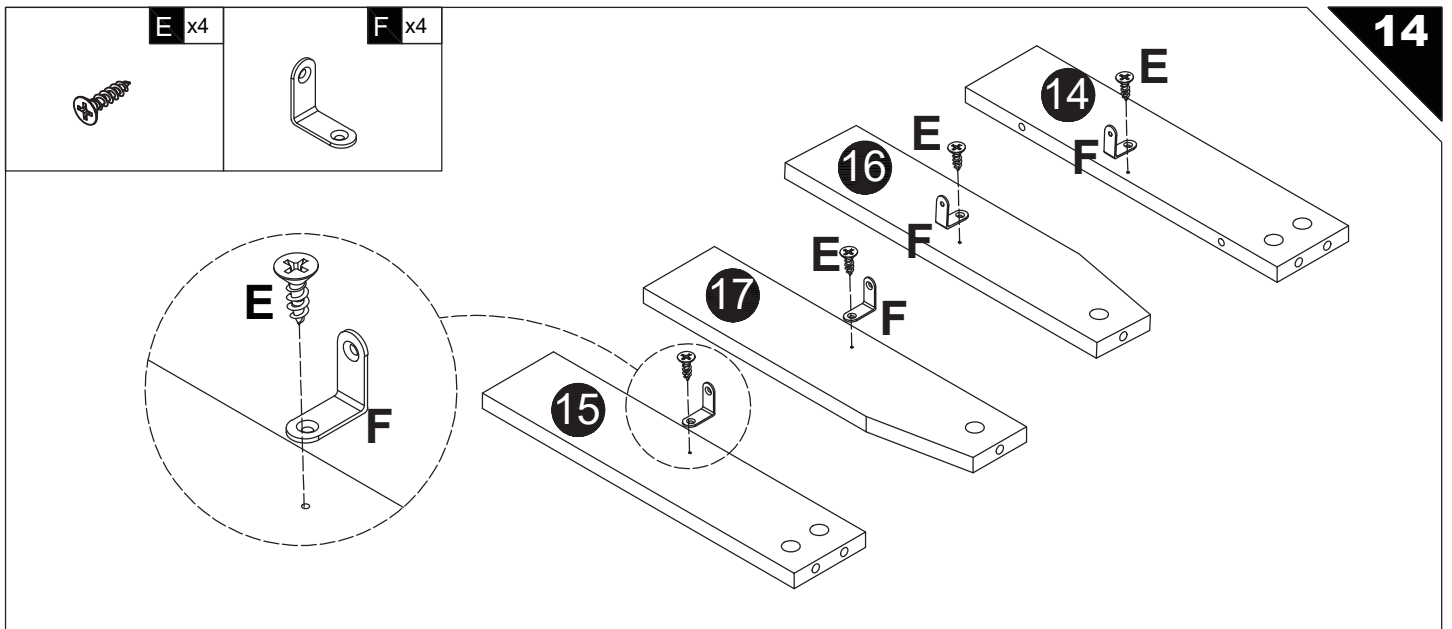

C x12



E x12

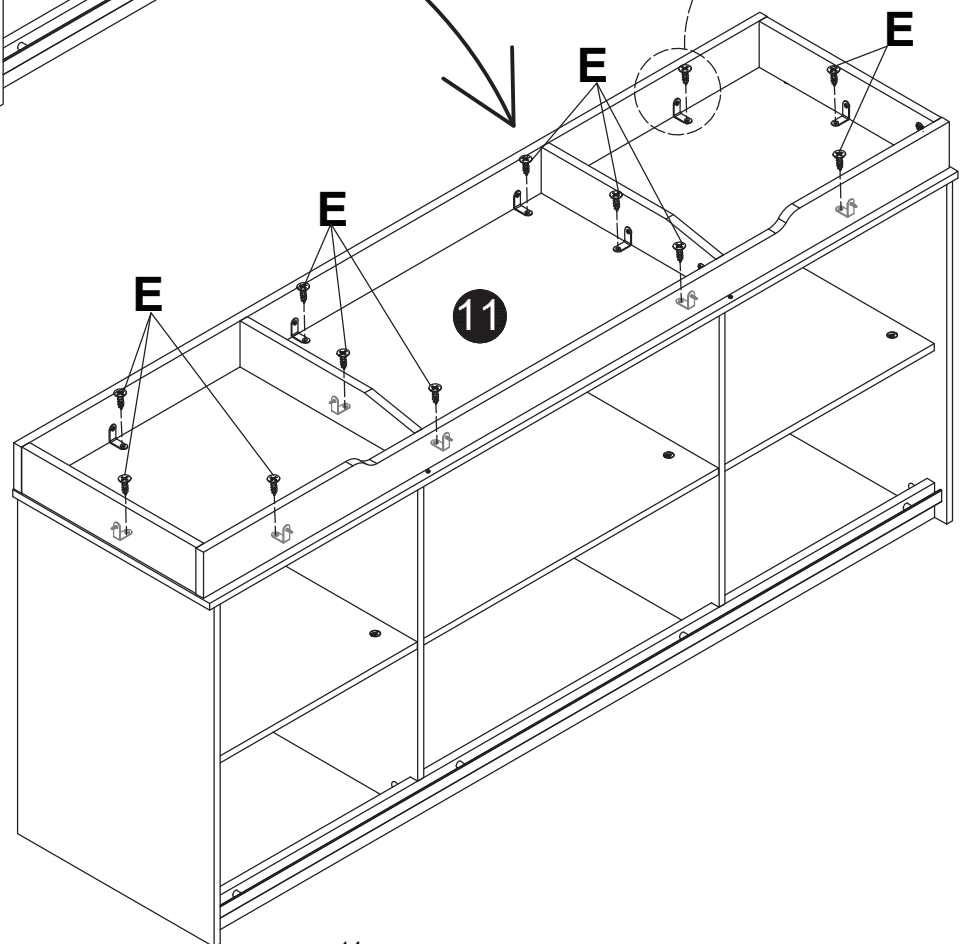
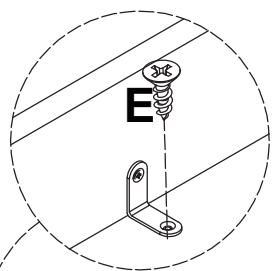
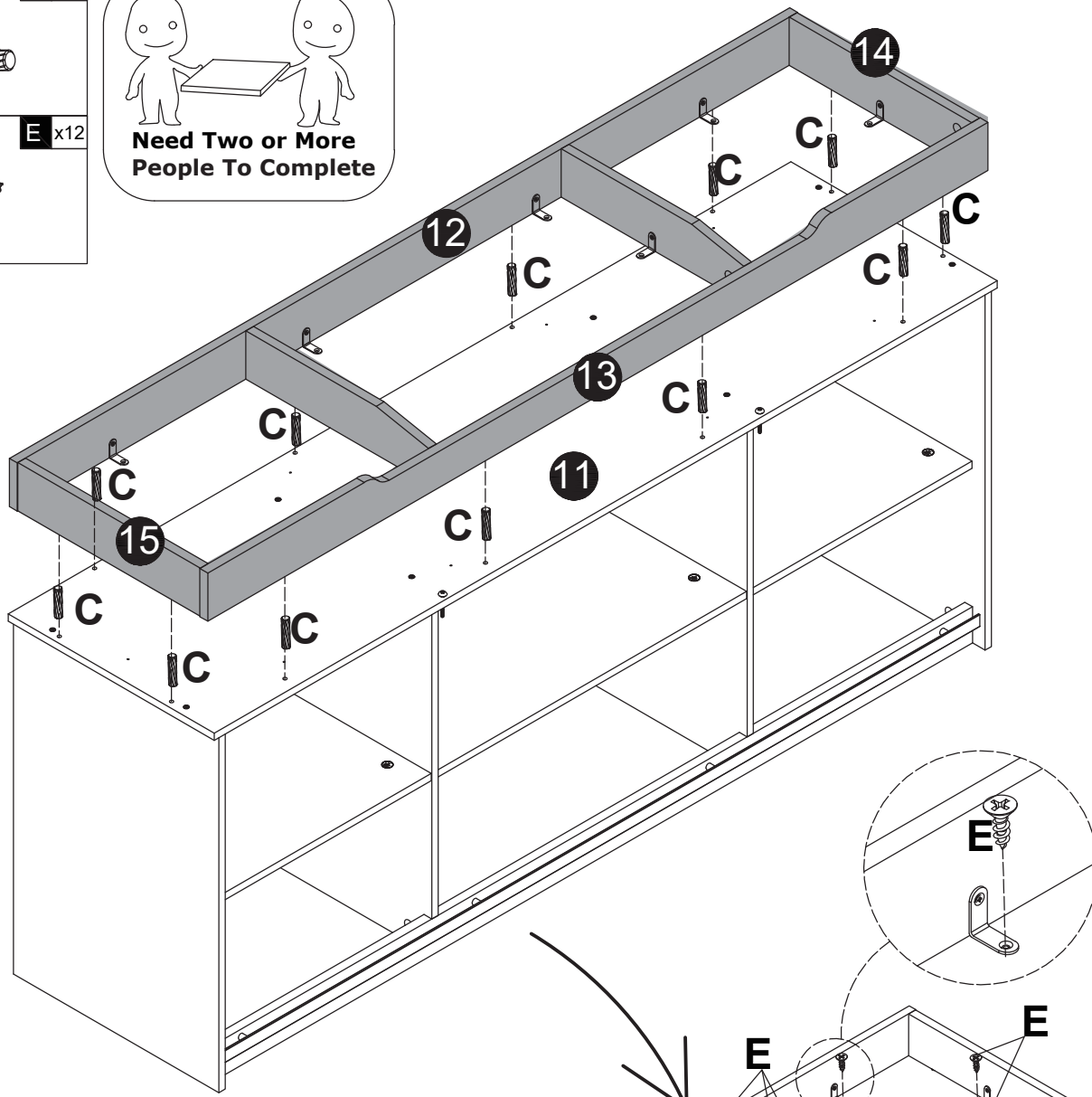
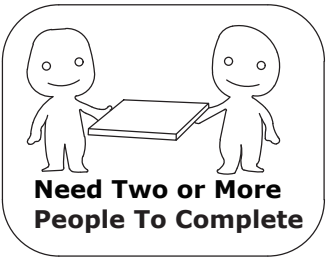

C x12

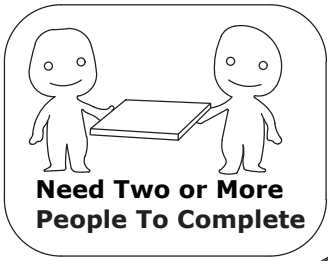

Need Two or More People To Complete

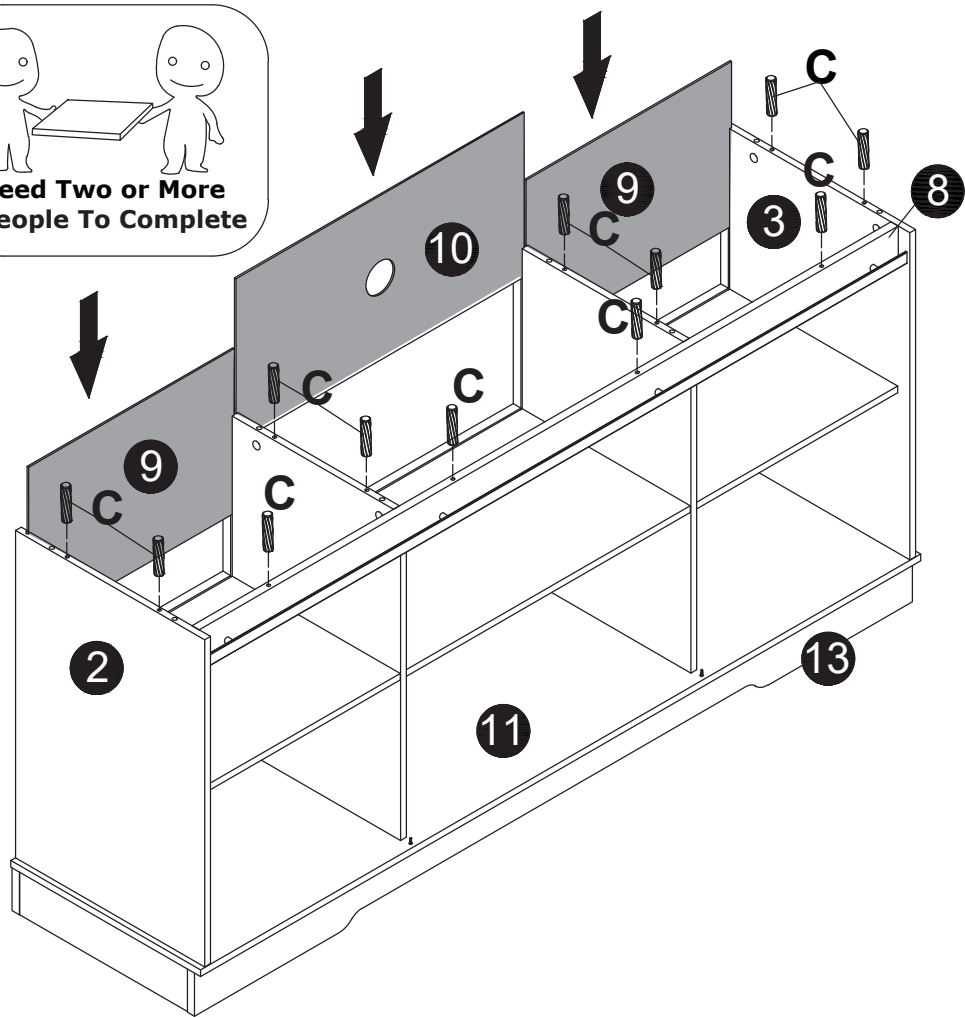

17

A x8

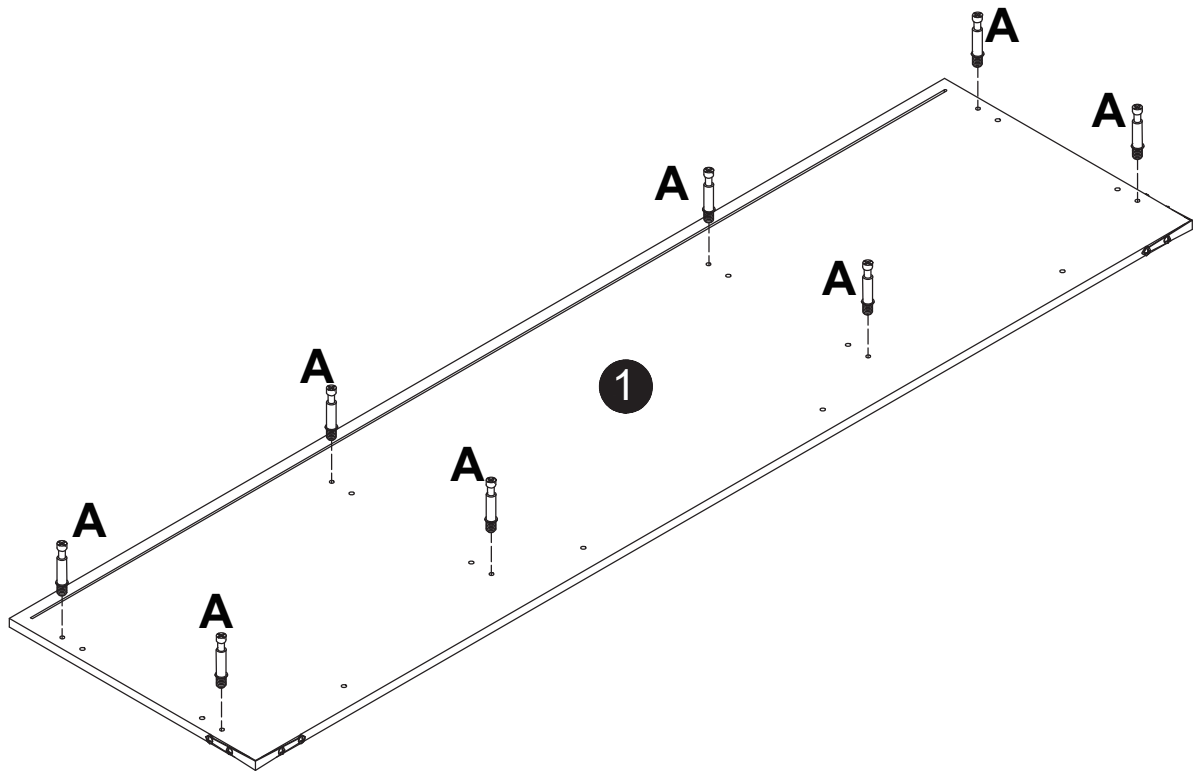
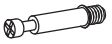

18

B x8

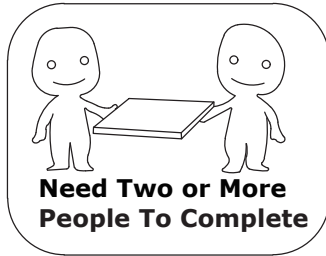

Need Two or More
People To Complete

19

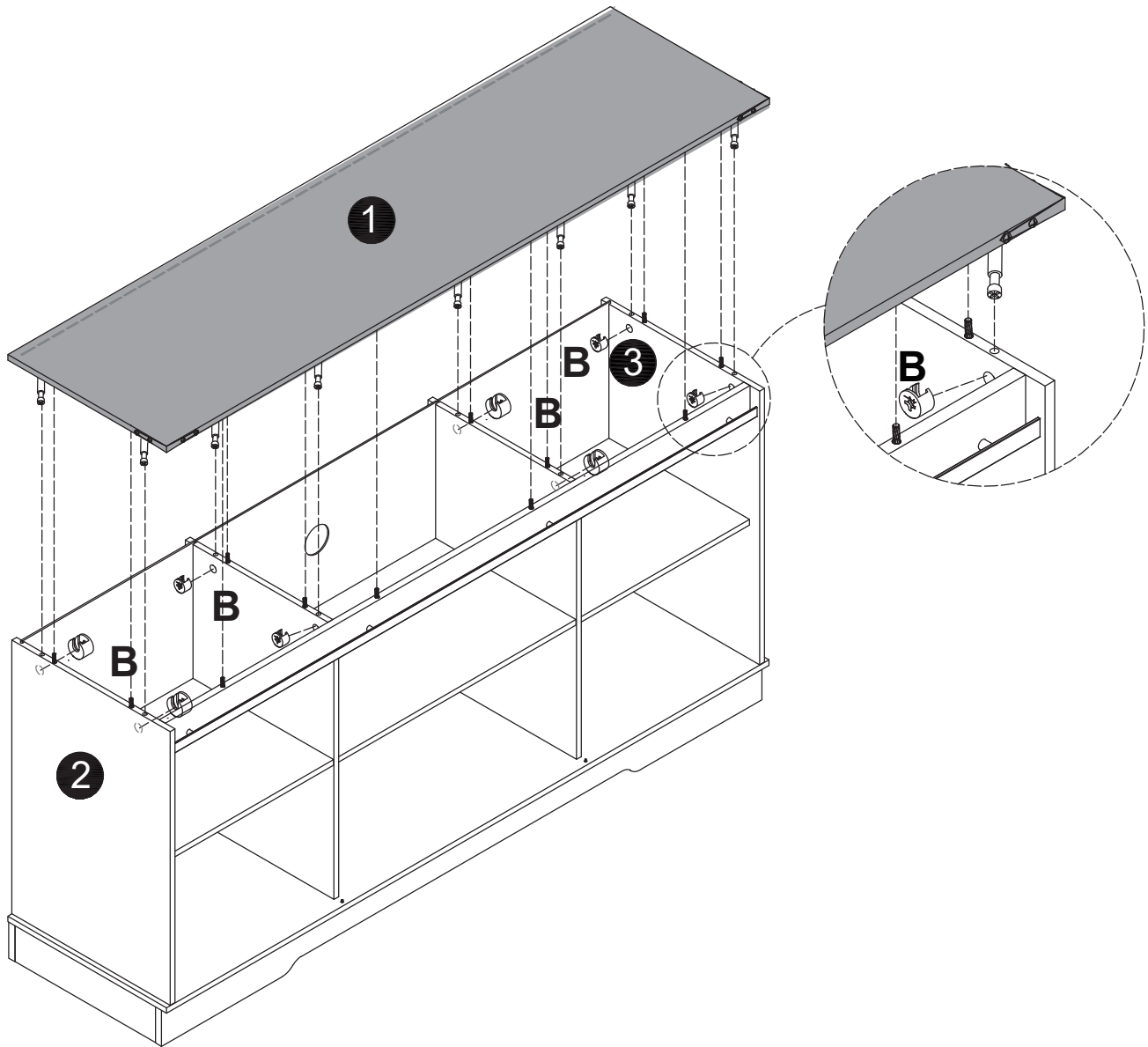

H1 H2 **H** x24

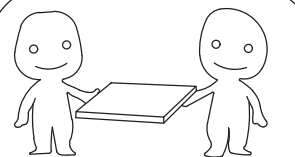
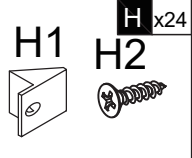

Need Two or More People To Complete

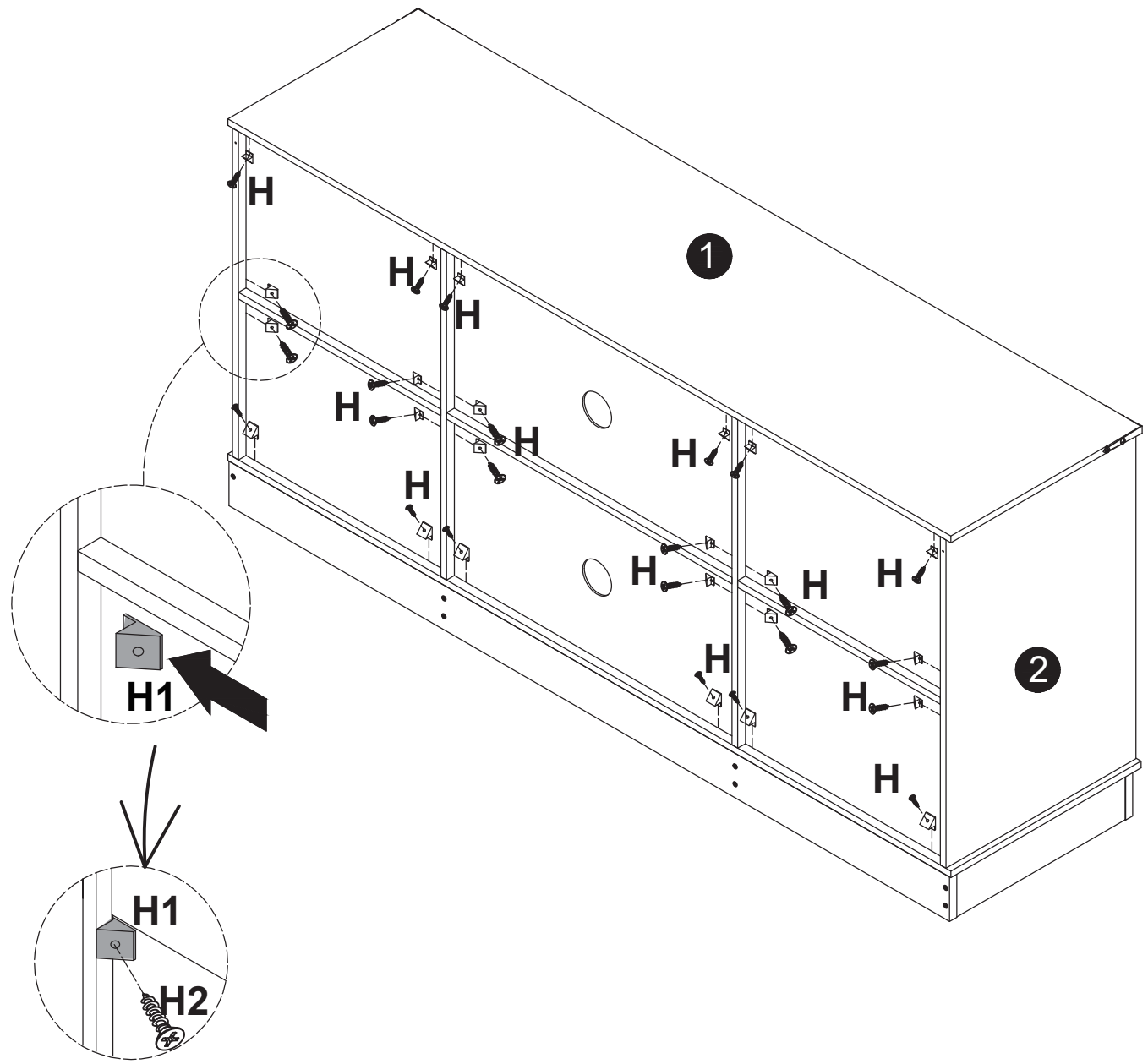

M x8

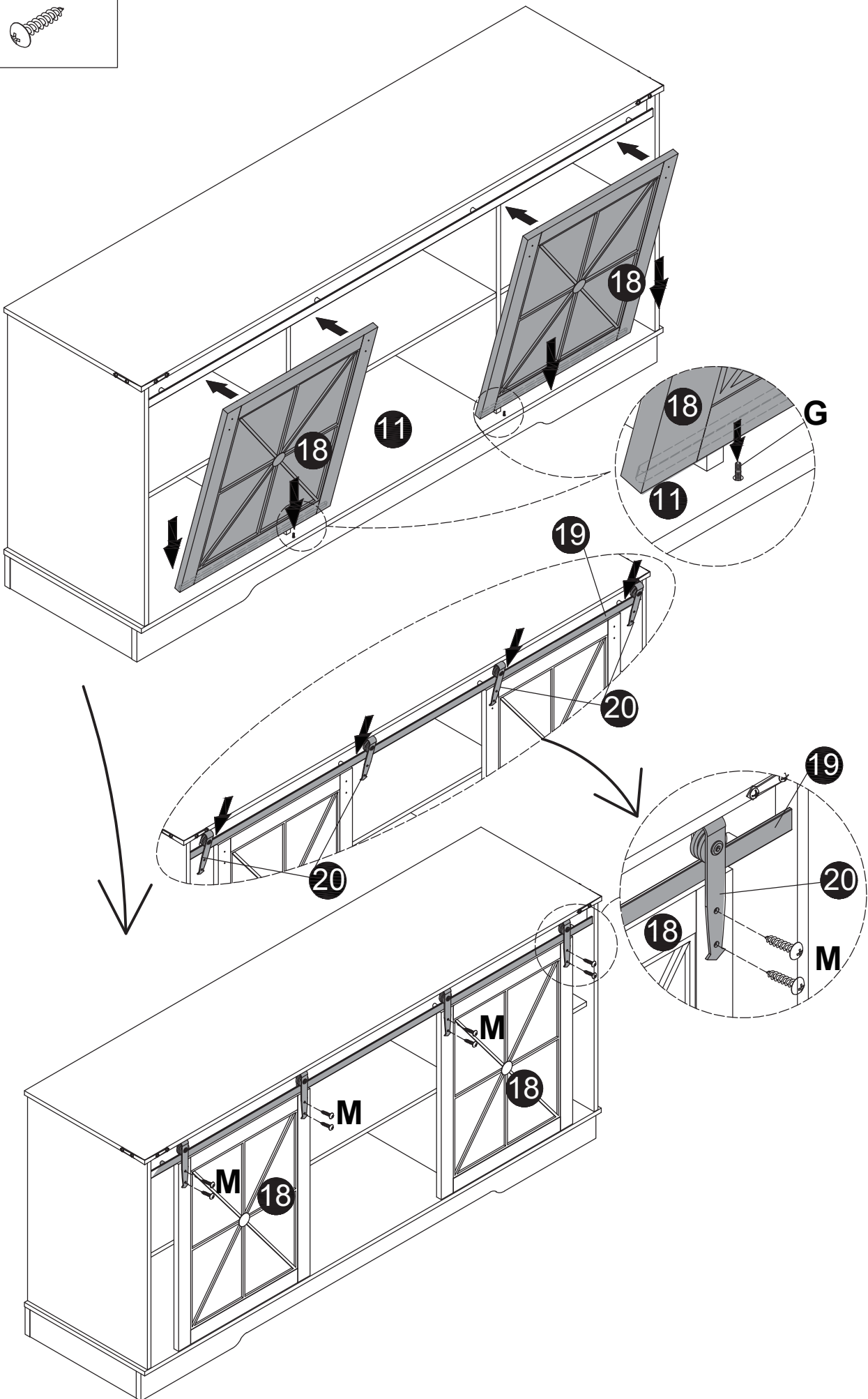

D x2



I x2



J x2



K x2

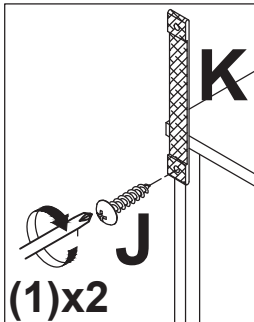

First fix the anti-rewind screw in the reserved hole of the product.

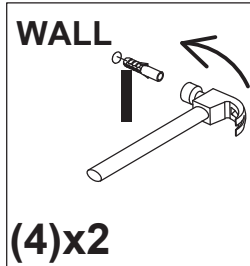

Then, put the expansion bolt into the hole

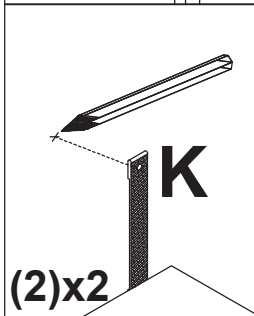

then, use a ruler to measure the approximate height of the product on the wall, and then mark it with a pen.

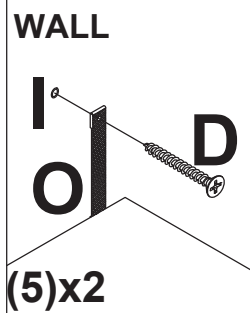

Finally, pass the matching screws through the "anti-rewind" and tighten them to fix them on the wall.

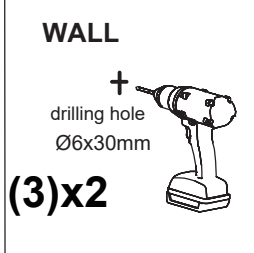

Then use a tape drill to make holes in the wall that are suitable for the product screws.

