

DBS(-H)

ASSEMBLY INSTRUCTIONS





IMPORTANT SAFETY INSTRUCTIONS



Read these instructions carefully and retain them for future use. If this product is passed to a third party, then these instructions must be included.

1. Safety Instructions

When using the product, basic safety precautions should always be followed to reduce the risk of injury including the following:

- This product must be assembled by an adult.
- Wearing gloves during assembly is highly recommended.
- Keep children and pets away while assembling the product.
- Do not let children climb on or play with the product.
- Always use the product on a firm, level ground.
- Do not use this product if any parts are missing, damaged, or worn.
- To avoid scratching the floor, assemble the product on a soft surface, such as a carpet.
- Do not over-tighten the fasteners.
- Regularly examine the product for wear and tear. Stop using the product at the first sign of damage or if parts become detached.
- Do not use power tools to assemble the product. Power tools may strip or damage the parts.
- Do not stand on the seat.
- Do not sit on the armrest.
- Keep all sharp objects away from the upholstery.
- Do not hang anything on the product.

2. Assembly

- For additional illustrated assembly steps, refer to the end of the written instructions.

3. Before First Use

- **Suffocation Hazard:** Packaging materials and small components such as screws, bolts, and other fasteners can pose a suffocation hazard. Always keep these parts out of reach of children and pets during assembly and ensure they are securely fastened to the product to prevent them from becoming loose over time.
- **Children's Safety:** Never leave children unattended with the chair. Teach children not to play with the chair, as it is not a toy. Climbing on the chair or playing with its moving parts can lead to falls or injuries. Additionally, ensure the chair is adjusted to a safe and appropriate height for children's use to prevent their feet from dangling, which can cause discomfort or pressure.
- **Pet Safety:** Be mindful of pets around your chair products. Pets, particularly those with a tendency to chew or claw, can damage the chair or even ingest small parts, leading to potential injury or health issues. Consider using protective covers or deterrents if your pets are known to chew on furniture.
- Remove all the packing materials.
- Review all components before assembly. Check the product for transport damages.

※Please make sure all the parts are included.



BACK X1

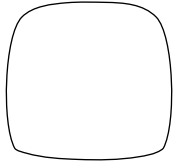

SEAT X1

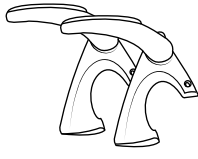

ARMREST X2

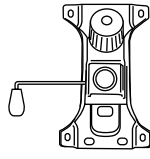

CONTROL MECHANISM X1

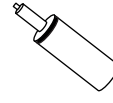

GAS LIFT CYLINDER X1



WHEEL X5

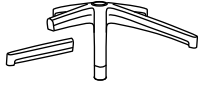

BASE X1
BASE LEG X1

Headrest models comes with below part

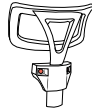

HEADREST X1



HEADREST BOLT X2



A X10
(SEAT + BACK ARMREST)



B X4
(CONTROL MECHANISM)



C X10
(WASHER)



D X1
(ALLEN KEY)

※ Detachable base leg is packed in a separate box.

NOTICE

Do not tighten the bolts all the way before each bolt is in place per step.

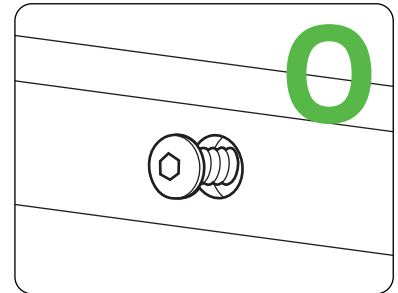
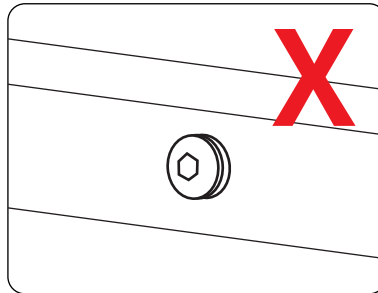

Please use the **Allen key** included instead of an electric drill.



TIPS!

Use the box for an easier assembly.

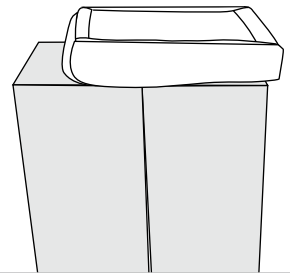

Enjoy your new favorite chair

Our goal is to create a perfect customer experience.

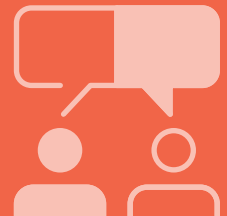

• Instructions

STEP 1 Bottom

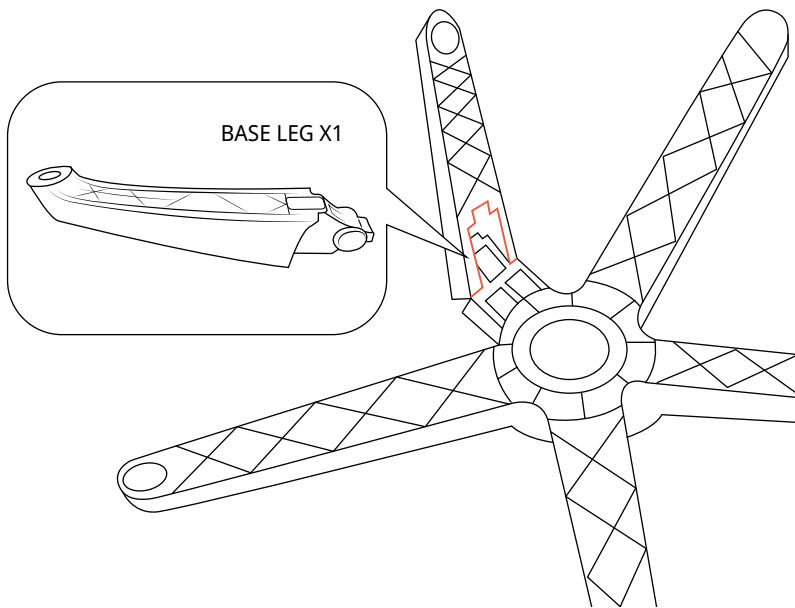

1. Insert the base leg vertically into the base.

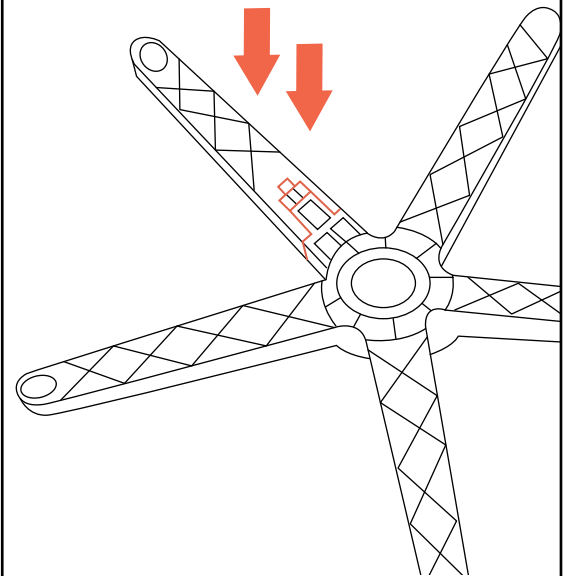

2. Press down firmly until the base leg is **FULLY SECURED**.

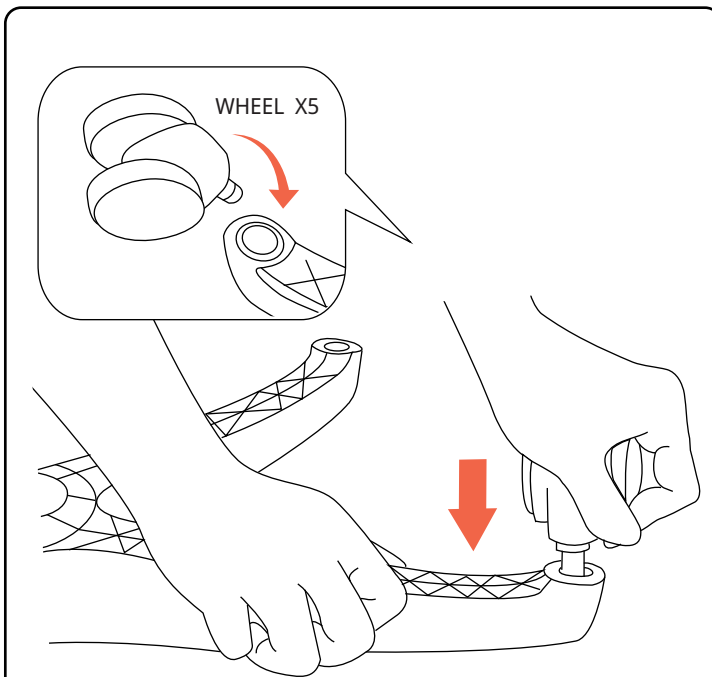

3. Fix the base leg with one hand and insert five wheels into the base.

SAFETY CAUTION

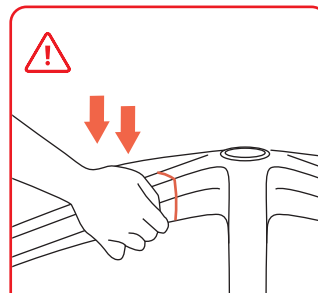

Ouch! Be careful not to get your hands caught in the gap.

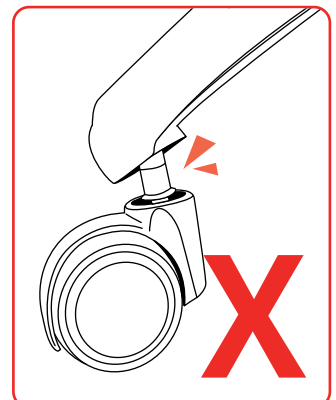
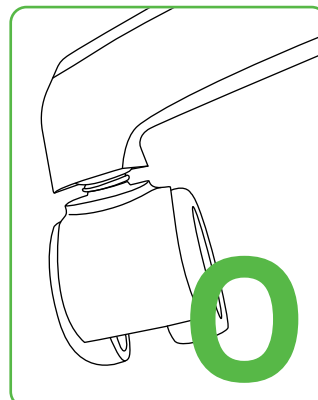
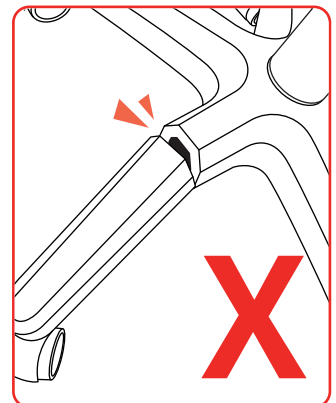

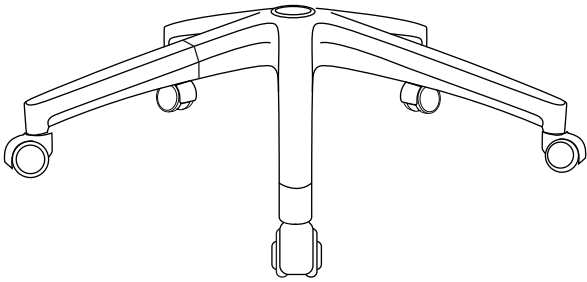

4. Turn the base over.

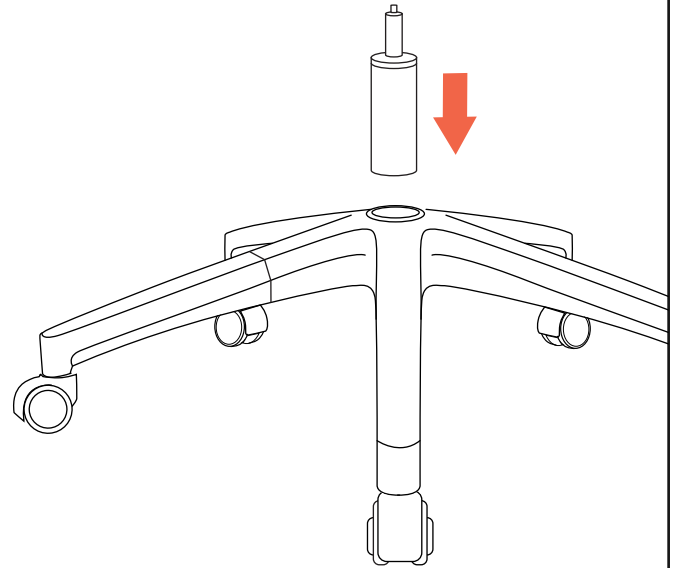

5. Insert gas lift cylinder into the center of the base.

STEP 2 Top

For proper alignment:
Slightly **under-tighten** the bolts.

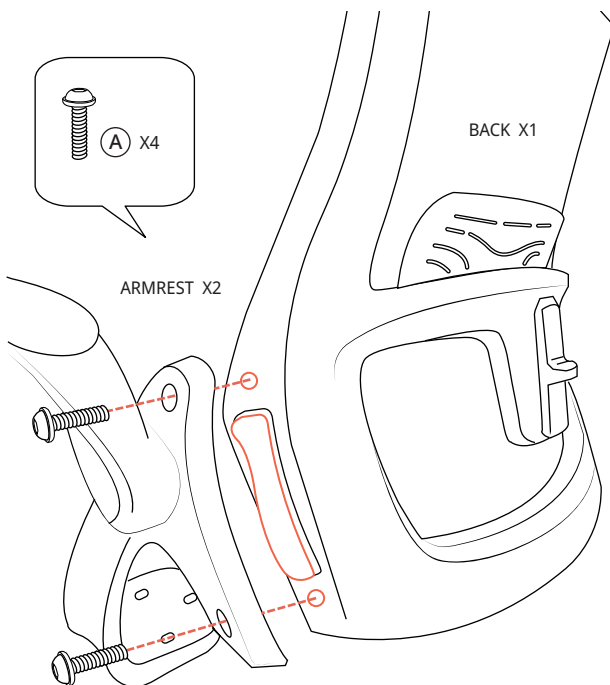

6. Line up the armrest and the back. Loosely tighten with two bolts. Repeat on the other side.

For proper alignment:
Slightly **under-tighten** the bolts.

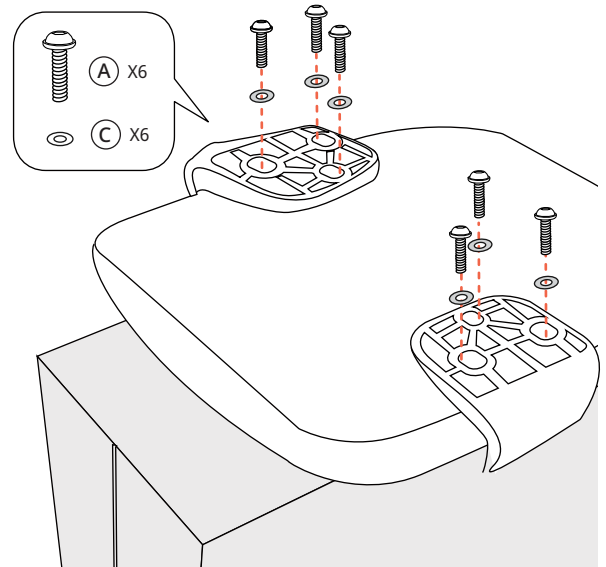

7. Put the armrests on the bottom of the seat and tighten with three bolts on each side.

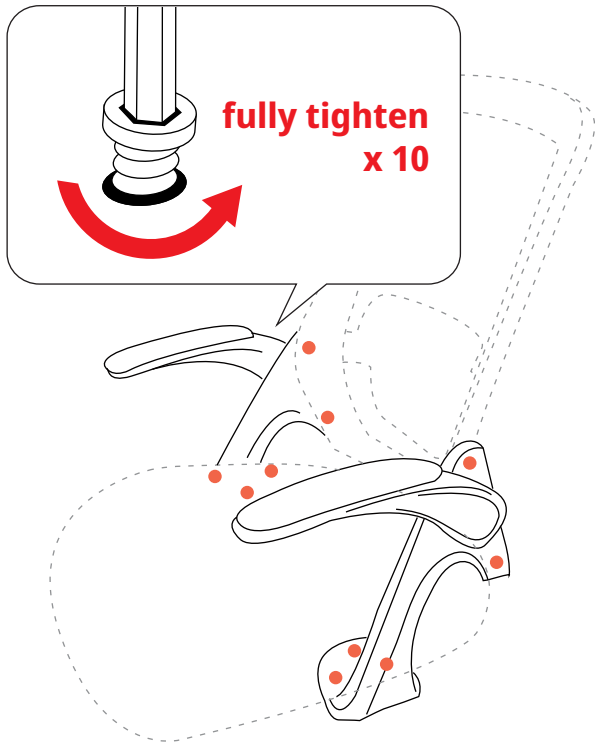

8. Once all of the armrest bolts are in place, **fully tighten** every bolt.

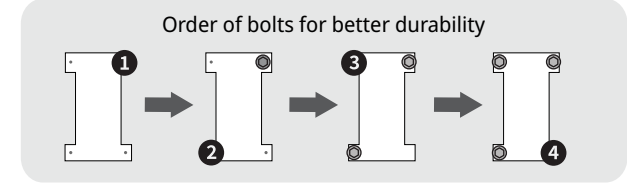
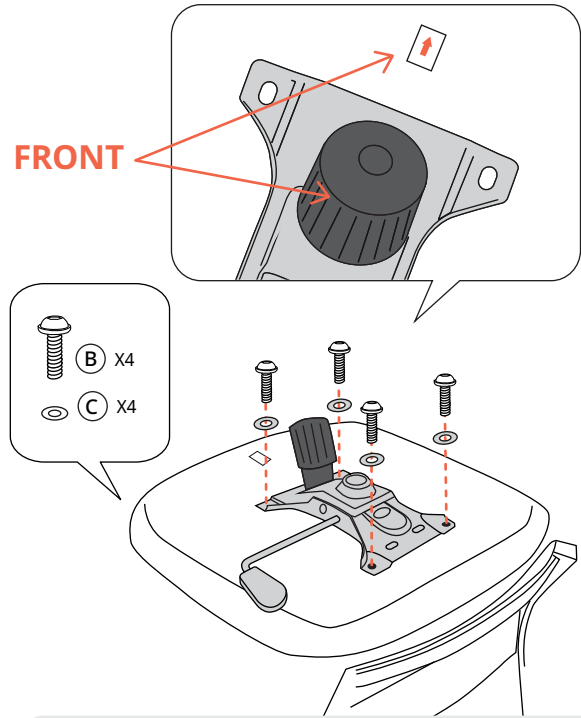

9. Align the control mechanism with the 'Front' sticker and secure it to the seat.

For headrest models only

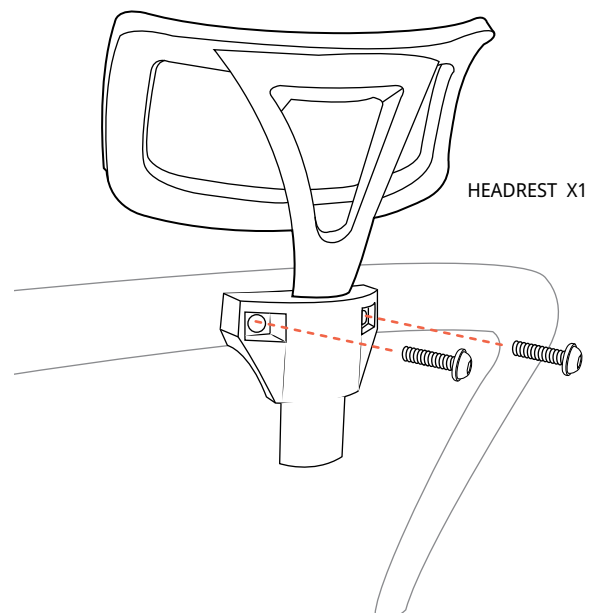

STEP 3 Top + Bottom

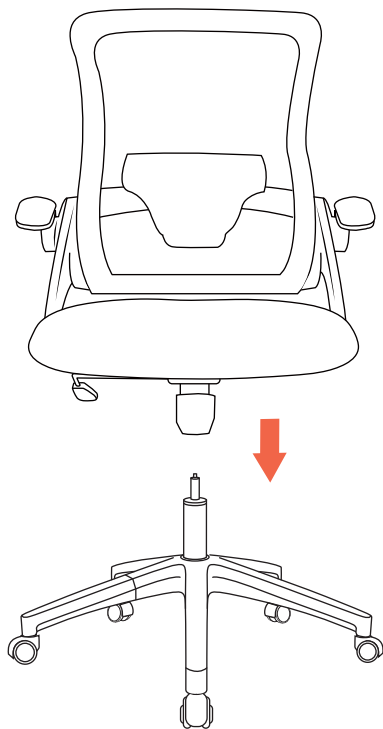

10. Mount the seat onto the gas lift cylinder.

• User Manual

