

Thank you for choosing . We stand behind our brand and the quality of the items we sell. Replacement parts or products can be requested within the 1-year warranty period. Proof of purchase must be provided. This includes the date of the purchase as well as photos of the product defect. Photos are used to determine the cause of the defect and to provide future quality control. The request will be reviewed, and replacement pieces will be sent at our discretion.

GENTLE GLOW 2-TIER CERAMIC OUTDOOR WATER FOUNTAIN

Review all assembly and care information before using this product. Save this manual for future reference.

Assemble components on a soft, clean surface to avoid damaging the finish.



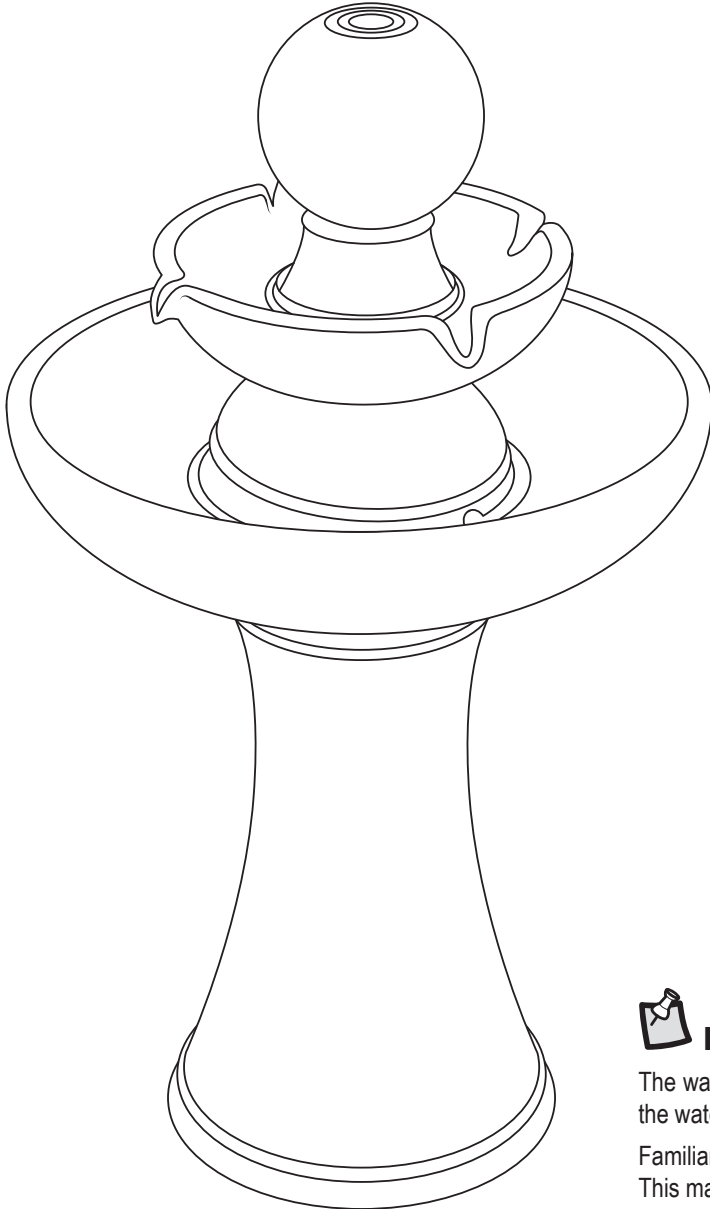

Select a smooth, level surface to place the fountain.



Inspect packaging to ensure all parts are accounted for before disposing of packing materials.
 Save the packing slip.

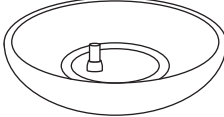
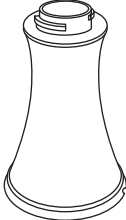

Trickling water sounds

PARTS		QTY.
	Top Tier	1
	Basin	1
	Pedestal	1
	Leak Guard	1
	Electric Submersible Pump	1
	AC Adapter	1



IMPORTANT NOTES:

The water tubing is built into the top tier. Take care when handling the water tube; detaching the water tube from the fountain will damage the unit and void the product warranty.

Familiarize yourself with the flow control valve on the pump, maximum (+) and minimum (-). This may need to be adjusted to achieve optimal water flow.

The lights and light cables are rated for contact with water.

WARNING:

Manufacturer and seller expressly disclaim any and all liability from personal injury, property damage or loss, whether direct or indirect, or incidental, resulting from the incorrect attachment, improper use, inadequate maintenance, or neglect of this product.

ASSEMBLY

STEP 1

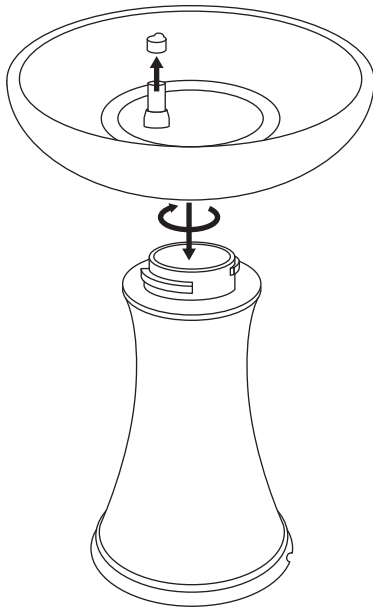

Place the bottom bowl on the pedestal and twist clockwise to lock into place.

Remove the leak guard from the basin tube.

STEP 2

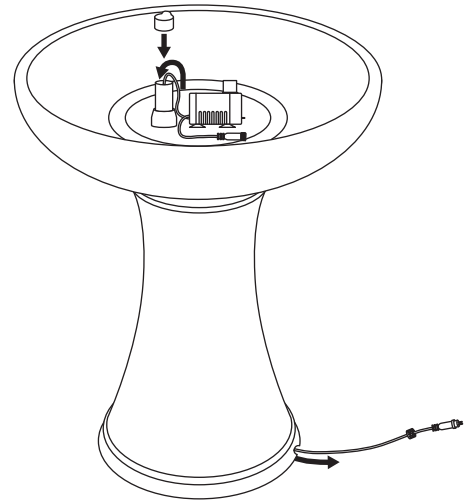

Run the long pump power cable through the tube in the basin and out through the groove in the bottom of the pedestal.

Ensuring the power cord is not pinched, install the leak guard on the basin tube.

STEP 3

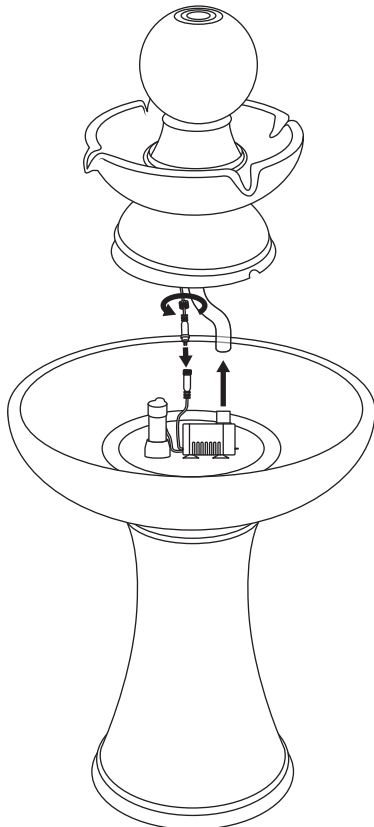

Locate the light cable in the top tier and firmly connect it to the short cable on the pump. Then, firmly attach the pump to the water tube.

STEP 4

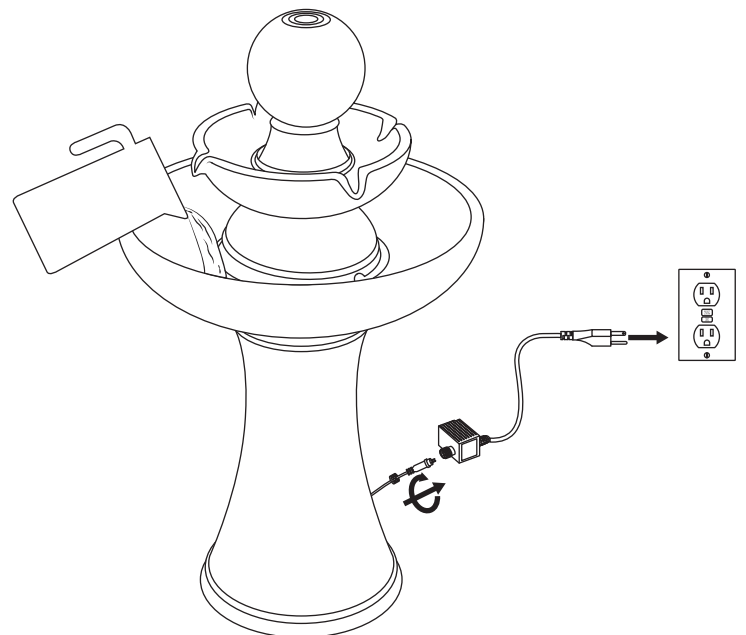

Firmly connect the pump power cable to the AC adapter. Fill the basin and top tier with enough water to keep the pump fully submerged during operation, approximately 10 cups.

Plug into a properly grounded GFCI outlet.

Care & Maintenance

- For outdoor use only. Some splashing is normal; adjust the flow rate on the pump if the water rate is too high.
- Check the water level frequently to ensure the pump remains fully submerged; never allow the pump to run dry as it will burn out the motor.
- Some climates and weather conditions increase water evaporation, requiring water to be refilled more frequently. During high temperatures, windy conditions, and long-term exposure to direct sunlight, check the pump often to ensure it does not run dry.
- Only use water in this fountain. Distilled water will help prevent mineral buildup but is not required. Tap water is okay to use; avoid heavily chlorinated water as it may damage the fountain or pump.
- Periodically change the water to keep the water, fountain, and pump clean. Remove scale and buildup regularly.
 - DO NOT use harmful additives such as bleach, chlorine, etc.
 - DO NOT use anything abrasive to scrub the fountain.
 - DO NOT use a pressure washer.
- Always shut off the power supply before cleaning and maintaining the fountain and the recirculating pump.
- Take care when handling the pump; only pick it up by the body of the pump, never the power cord.
- During freezing weather, drain the fountain, disconnect the pump and store it indoors; allowing ice to form will crack the ceramic.

Troubleshooting

- If water is not flowing within several moments of the fountain being plugged in, the pump may have air bubbles in the filter, which can prevent water from circulating properly and can also cause excess pump noise.
- Ensure that the pump is fully submerged underwater; add water to the reservoir as necessary.
- Check the flow control on the body of the pump, as it may need to be adjusted to achieve the desired water flow rate.
- Inspect the pump and tubing for obstructions.
- Pump noise can be caused by trapped air, low water level, or the pump being too close to the walls of the fountain. While the pump is fully submerged, try gently tapping the pump with your finger to help release the trapped air. Also, check if adding water or moving the pump helps to reduce noise.
- If the light is not working, ensure the cables are fully connected and the seal is adequately tightened (do not over-tighten). Ensure connector ends are completely dry before connecting and plugging the power cord into an outlet.
- Soft surfaces may cause the fountain to become unbalanced. A large stepping stone or paving stone (not included) is recommended to help ensure the fountain remains evenly balanced.
- Check to make sure the power outlet is working; consult a certified electrician if in doubt about electrical connections.

If you experience issues with assembly or the product was damaged during transit, please contact our customer service team through one of the methods mentioned at the top of page 1. Please have the item number and order information ready to expedite response time.

! SAFETY STATEMENTS & WARNINGS !

- For outdoor use only.
- Keep fountain out of reach of children and pets.
- Prevent water loss and damage to electrical sockets by ensuring the power cord has a drip loop; a diagram of a drip loop is shown on the right.
- Make sure the power cord is away from traffic areas.
- Keep power cord away from all heat sources. Do not use electrical cords in areas with high temperatures.
- Check the water level frequently to ensure the pump remains fully submerged; never allow the pump to run dry as it will burn out the motor.
- Always unplug the power supply before cleaning and maintaining the fountain and the recirculating pump.
- Take care when handling the pump; only pick it up by the body of the pump, never by the power cord.

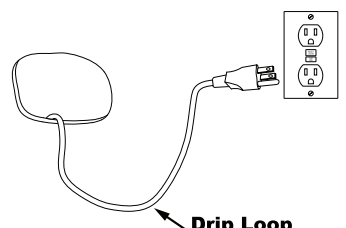

Drawing is for visual reference only, cord placement and plug type vary by fountain style.

Any modification to the product or failure to follow recommended care will void the product warranty.

! WARNING:

Manufacturer and seller expressly disclaim any and all liability from personal injury, property damage or loss, whether direct or indirect, or incidental, resulting from the incorrect attachment, improper use, inadequate maintenance, or neglect of this product.