

# ASSEMBLY INSTRUCTION

## DINNING SET

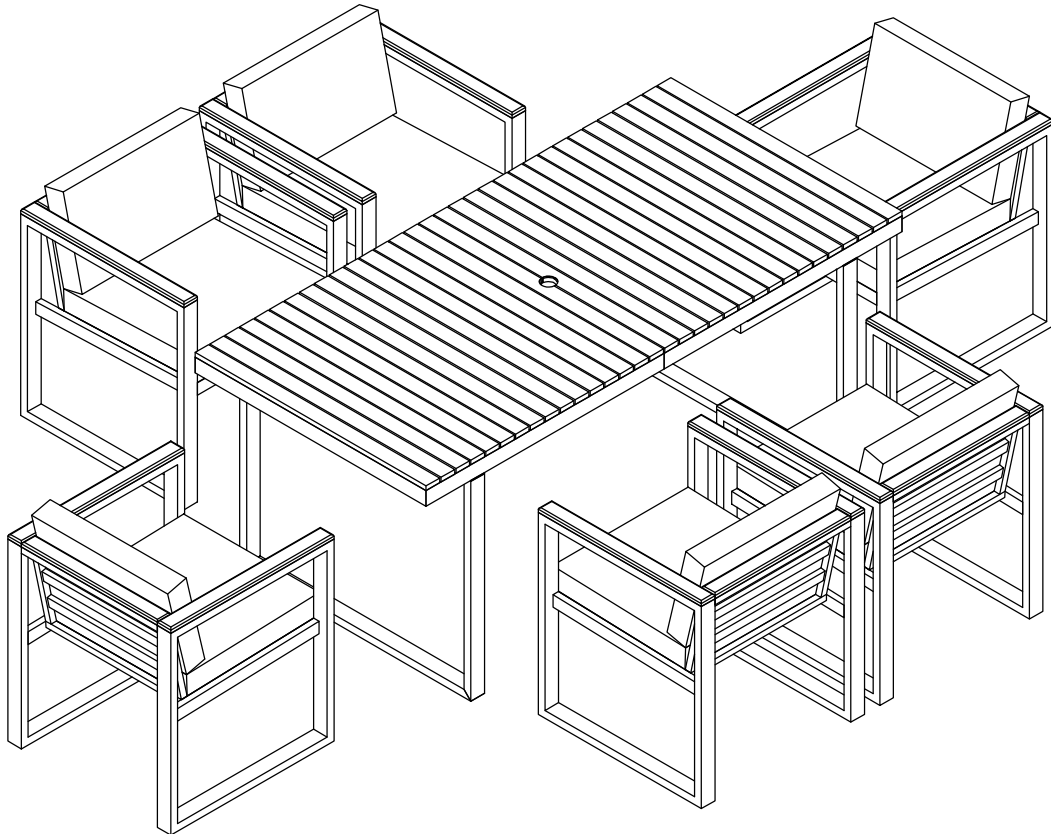

**Notice:**

- 1. 50% Tighten before fixing all screws, Allen wrench is recommended instead of an electric drill.**
- 2. Place the item on a flat ground to adjust and make sure it remains stable.**
- 3. Tighten up all screws with tools gradually.**
- 4. If the screws are not aligned with holes during assembly, please loosen all the other screws to 50% and continue the assembly process.**
- 5. If the item is not stable, please loosen all the screws, adjust it on a flat ground and tighten up all screws again.**
- 6. Note : If one or some screws are fully tightened during assembly, chances are the others will not be aligned with holes. In addition, all the holes are designed to be relatively larger to provide more space for the adjustment of the screws.**

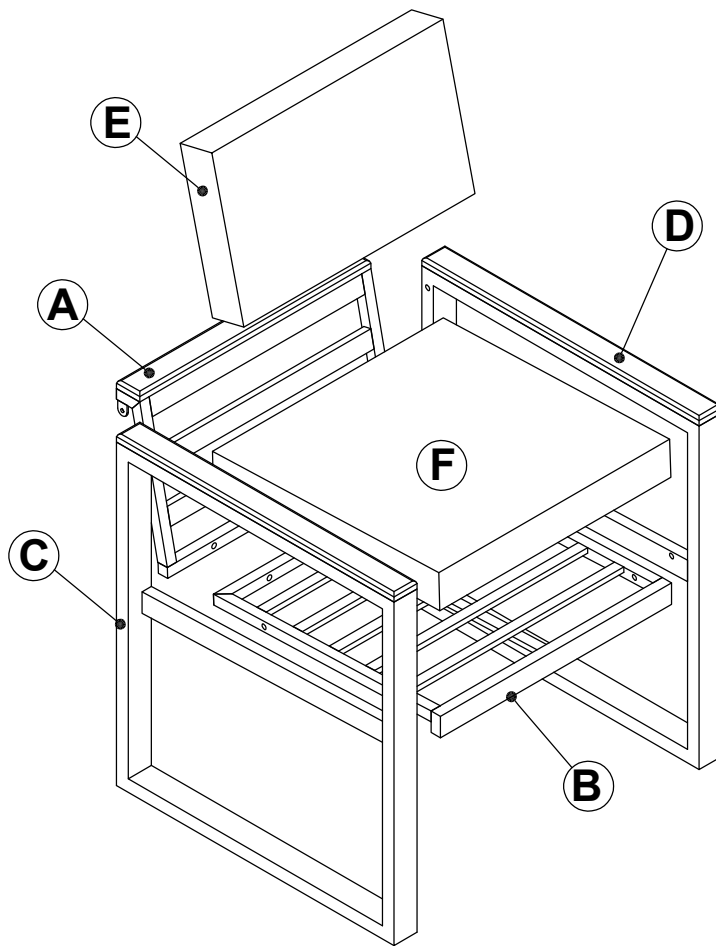

**x6**

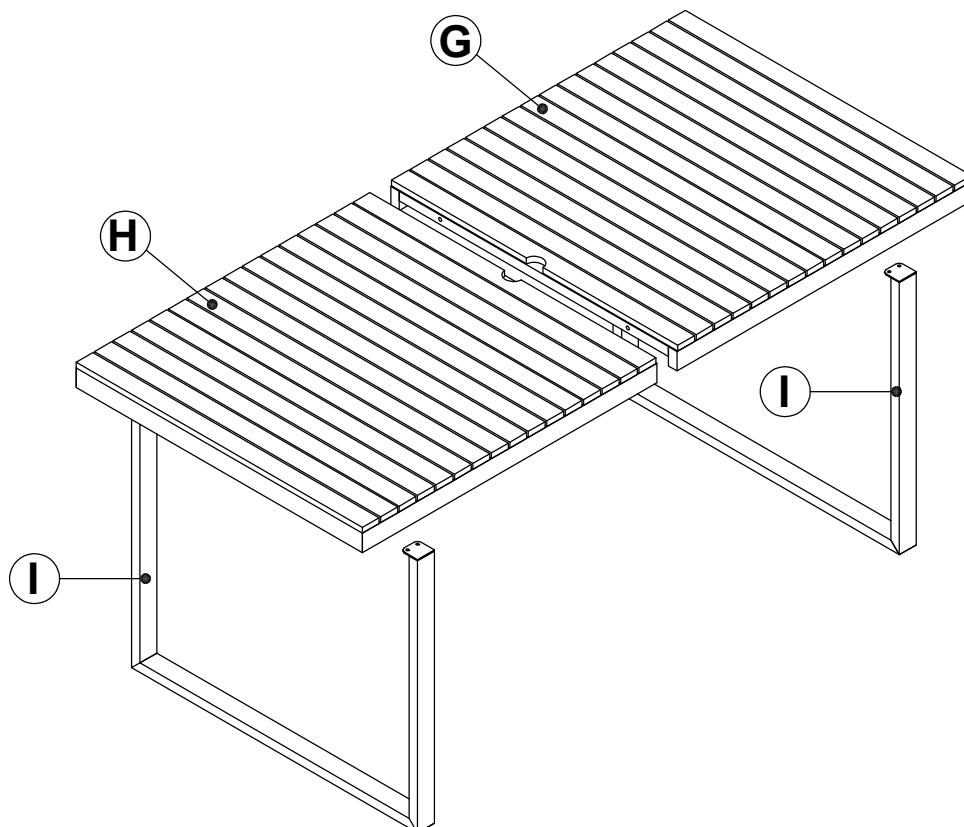

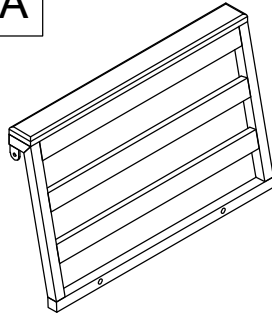
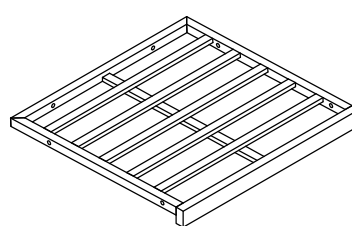
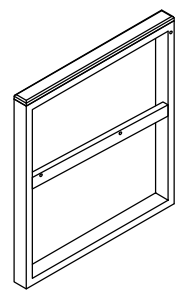
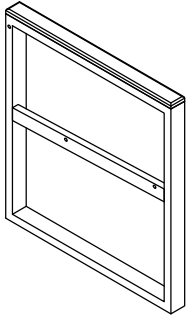
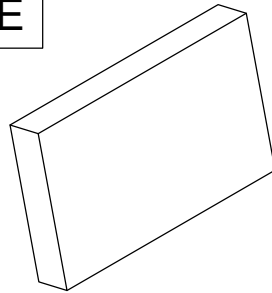
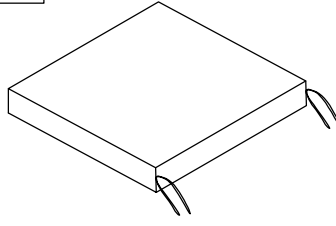
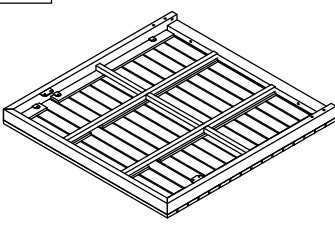
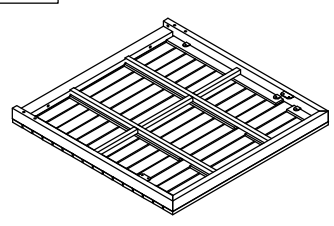
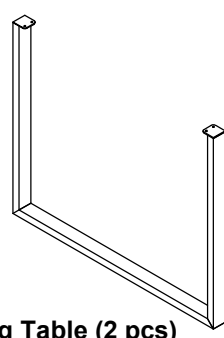

**x1**

## Part List:

<p><b>A</b></p>  <p><b>Back Chair Frame (6 pcs)</b></p>	<p><b>B</b></p>  <p><b>Seat Chair Frame (6 pcs)</b></p>	<p><b>C</b></p>  <p><b>Left Leg (6 pcs)</b></p>	<p><b>D</b></p>  <p><b>Right Leg (6 pcs)</b></p>
<p><b>E</b></p>  <p><b>Back Cushion (6 pcs)</b></p>	<p><b>F</b></p>  <p><b>Seat Cushion (6 pcs)</b></p>	<p><b>G</b></p>  <p><b>Top Table (1 pcs)</b></p>	<p><b>H</b></p>  <p><b>Top Table (1 pcs)</b></p>
<p><b>I</b></p>  <p><b>Leg Table (2 pcs)</b></p>			

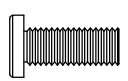
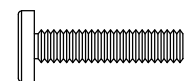
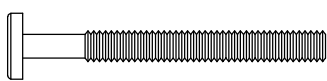
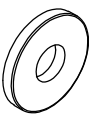
## Hardware List:

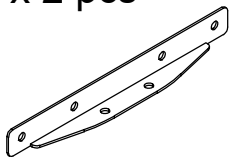
<p><b>1</b> x 32 pcs</p>  <p>Extra (3 pcs) BOLT M6 x 20 MM</p>	<p><b>2</b> x 36 pcs</p>  <p>Extra (3 pcs) BOLT M6 x 35 MM</p>	<p><b>3</b> x 2 pcs</p>  <p>BOLT M6 x 75 MM</p>	<p><b>4</b> x 70 pcs</p>  <p>Extra (3 pcs) Flat Washer M6</p>
<p><b>5</b> x 2 pcs</p>  <p>ALLEN KEY</p>	<p><b>6</b> x 2 pcs</p>  <p>CONECTOR</p>		

# CARTON CONTENT:

A x3

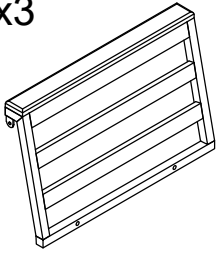

B x3

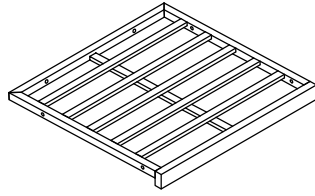

C x3

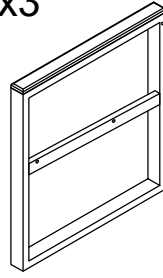

D x 3

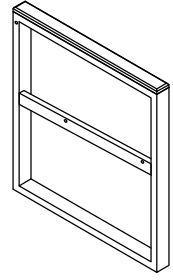

E x 2

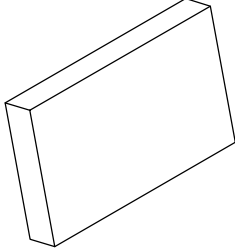

F x 3

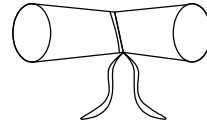
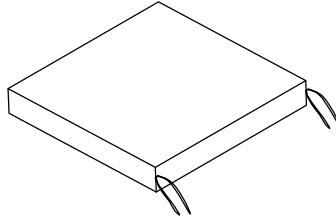

Hardware

A x3

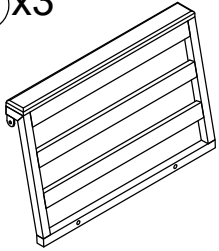

B x3

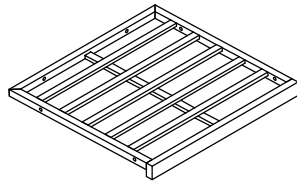

C x3

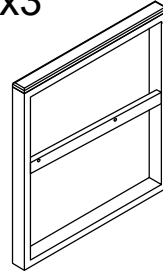

D x 3

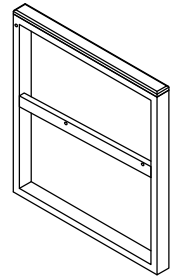

E x 2

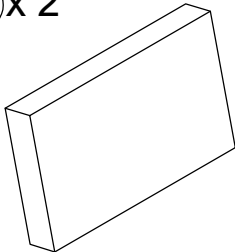

F x 3

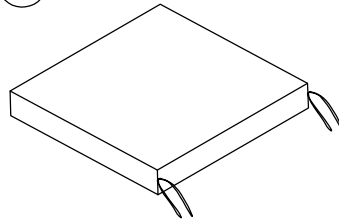

G x 1

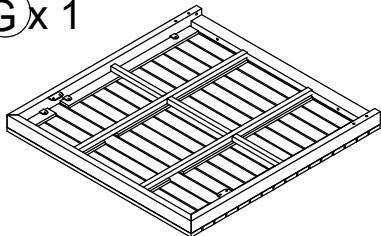

H x 1

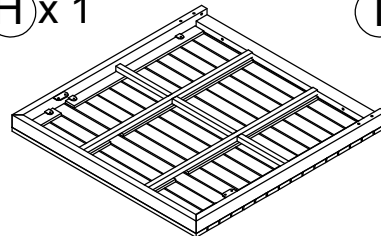

I x 2

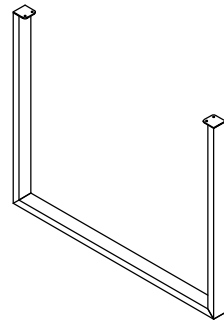

E x 2

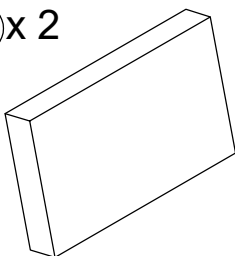

### STEP 1

A	x1
B	x1
2	x2
4	x2

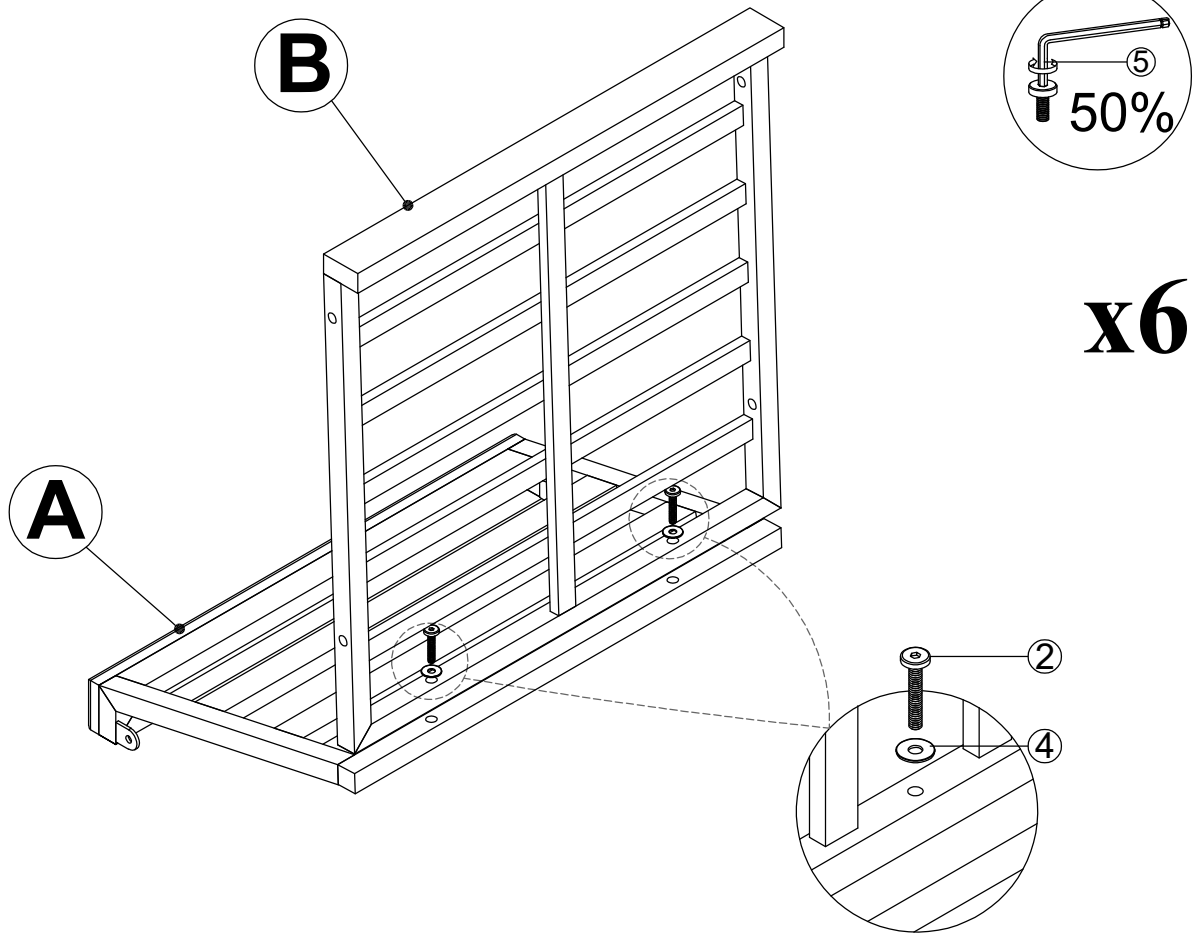

Connect Seat Chair (B) & Back Chair (A), Tighten Bolt (2) & Flat Washer (4) with Allen Key (5).

### STEP 2

C	x1
2	x2
4	x2

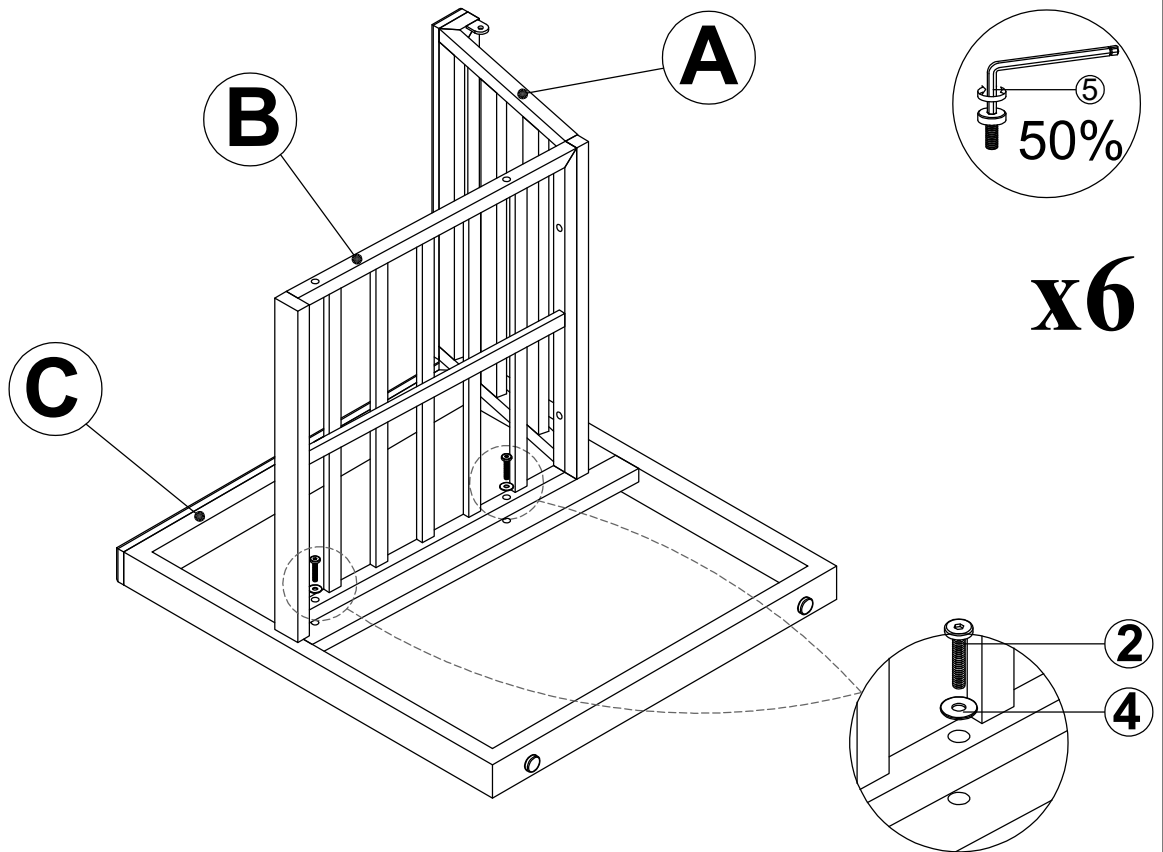

Connect the part from step 1 & Left Leg (C), Tighten Bolt (2) & Flat Washer (4) with Allen Key (5).

**STEP 3**

1 x1

4 x1

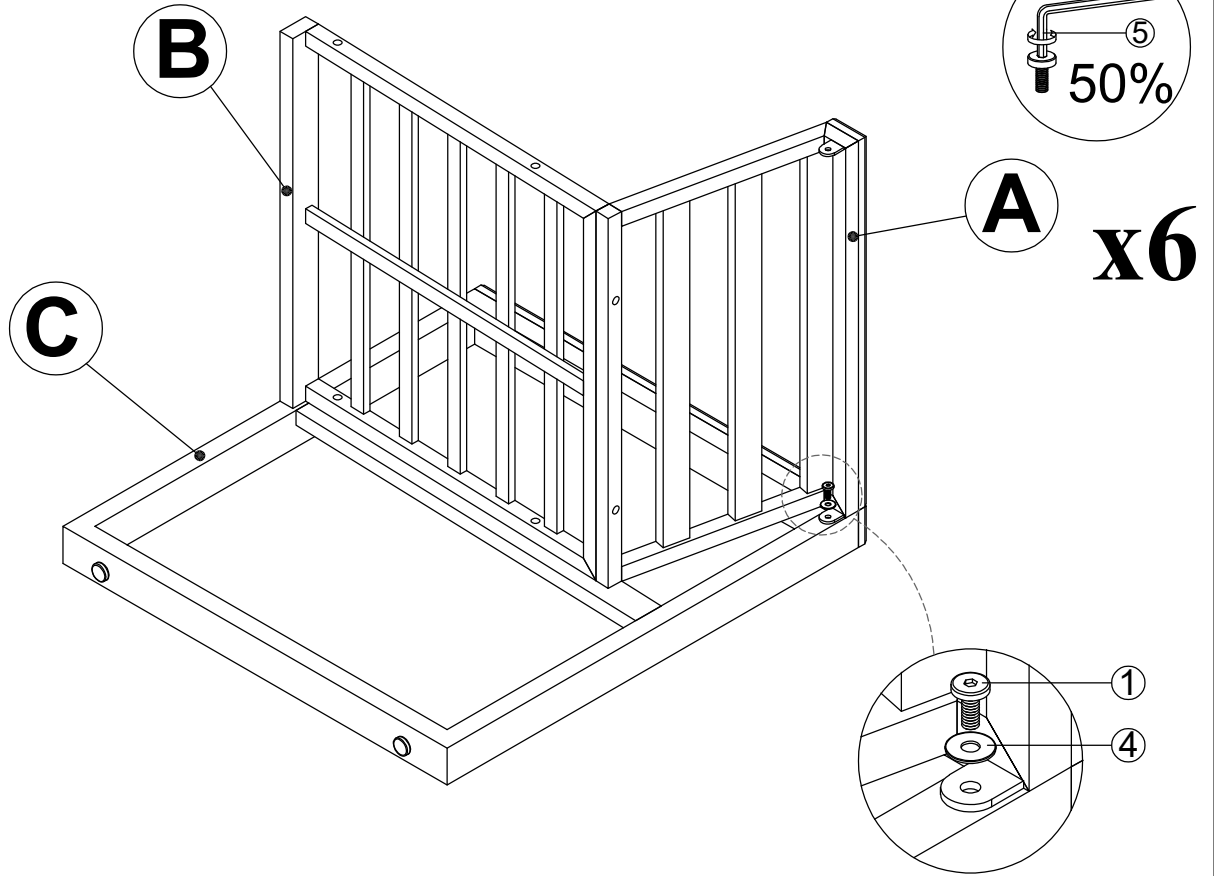

Connect the part from step 2, Tighten Bolt (1) & Flat Washer (4) with Allen Key (5).

**STEP 4**

D x1

2 x2

4 x2

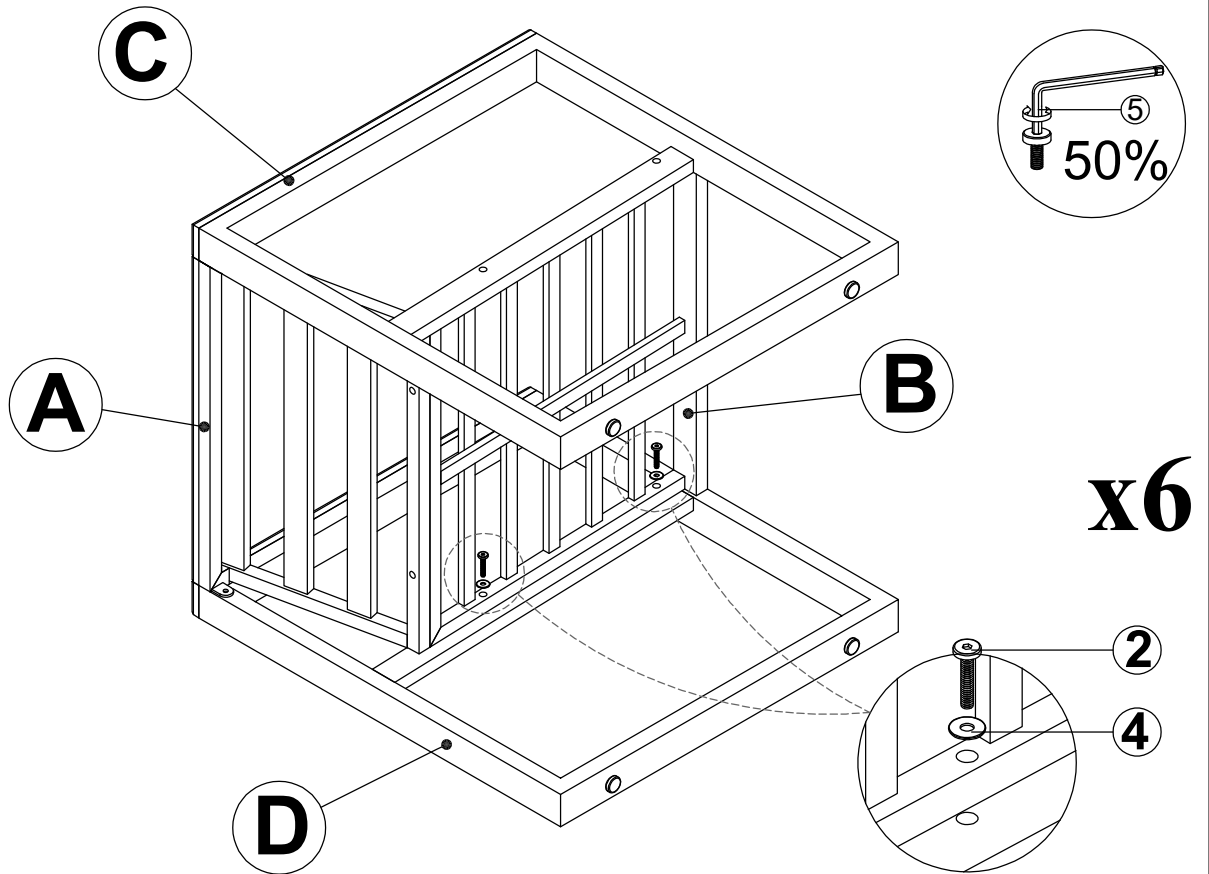

Connect the part from step 3 & Right Leg (D), Tighten Bolt (2) & Flat Washer (4) with Allen Key (5).

### STEP 5

- 1 x1
- 4 x1

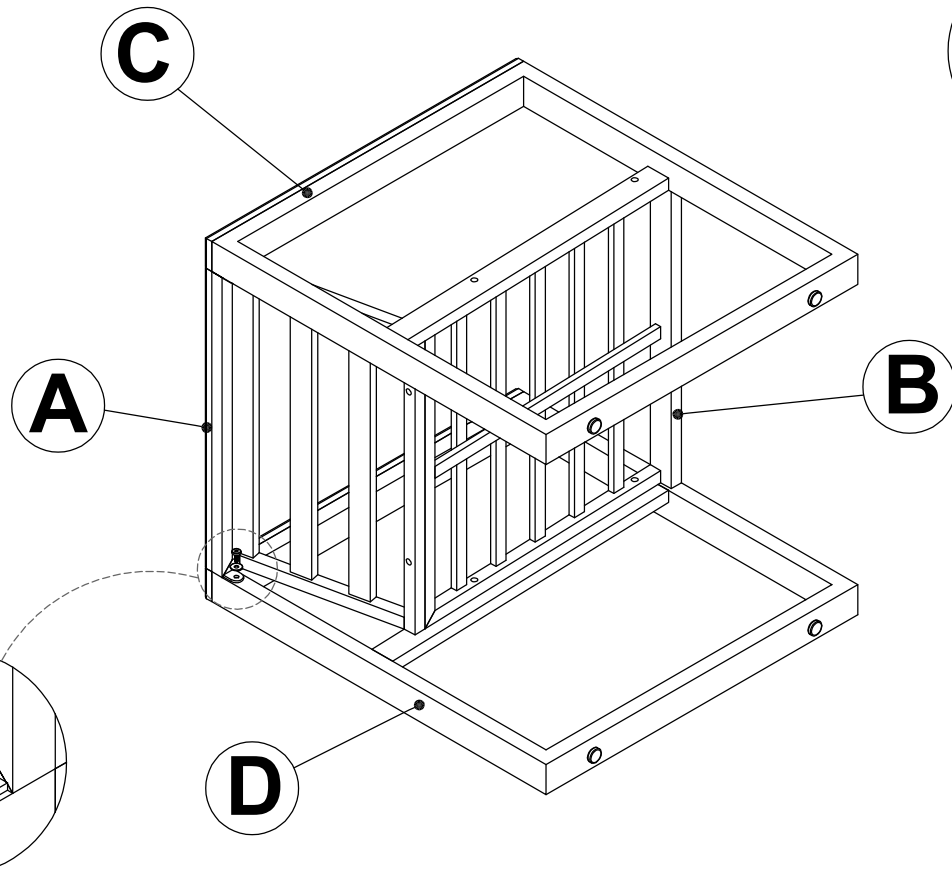
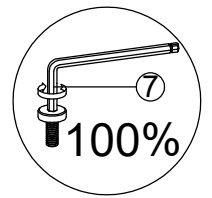

x6

Connect the part from step 4, Tighten Bolt (1) & Flat Washer (4) with Allen Key (5).

### STEP 6

- E x1
- F x1

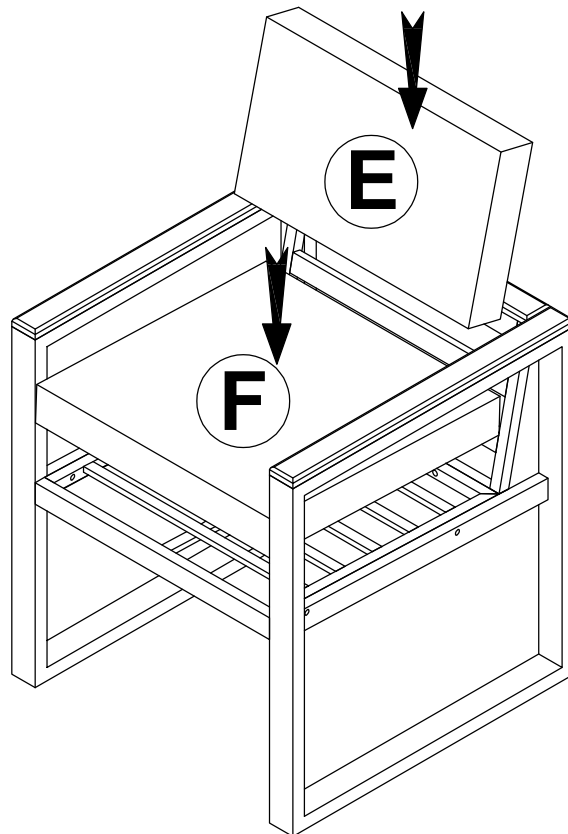

x6

Open all the bags, adjust the cushions, Set up the Back Cushions (E) + Seat Cushions (F).

**STEP 7**

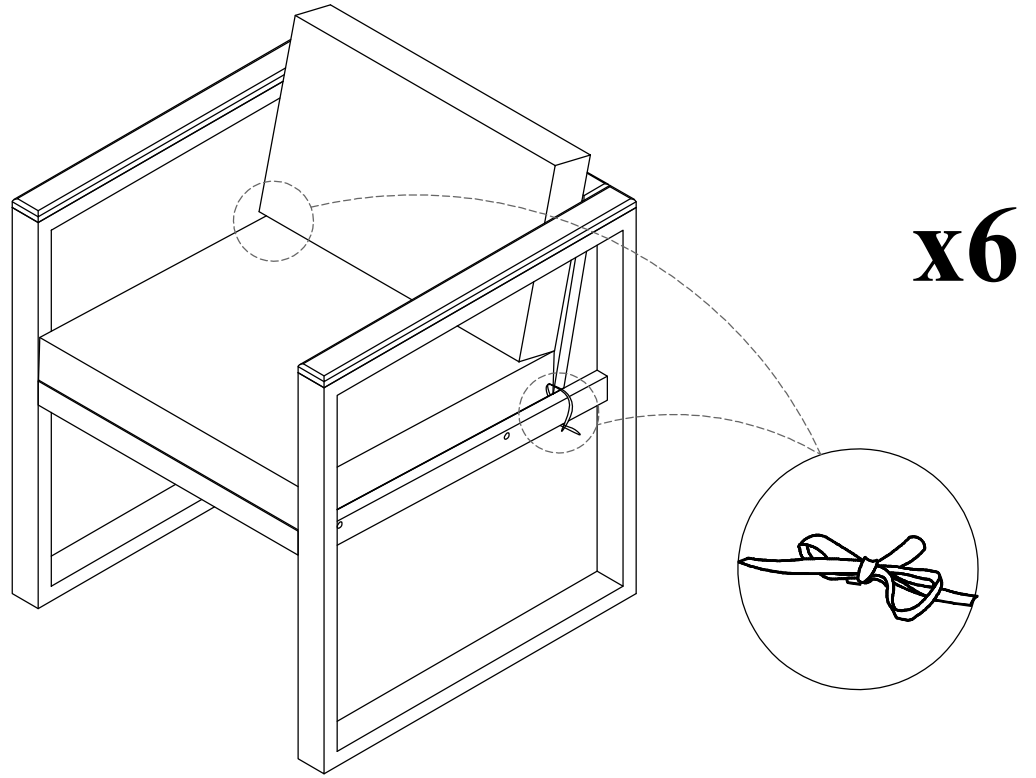

Finish Chair.

**STEP 8**

<b>G</b>	<b>x1</b>
<b>H</b>	<b>x1</b>
<b>3</b>	<b>x2</b>
<b>4</b>	<b>x2</b>

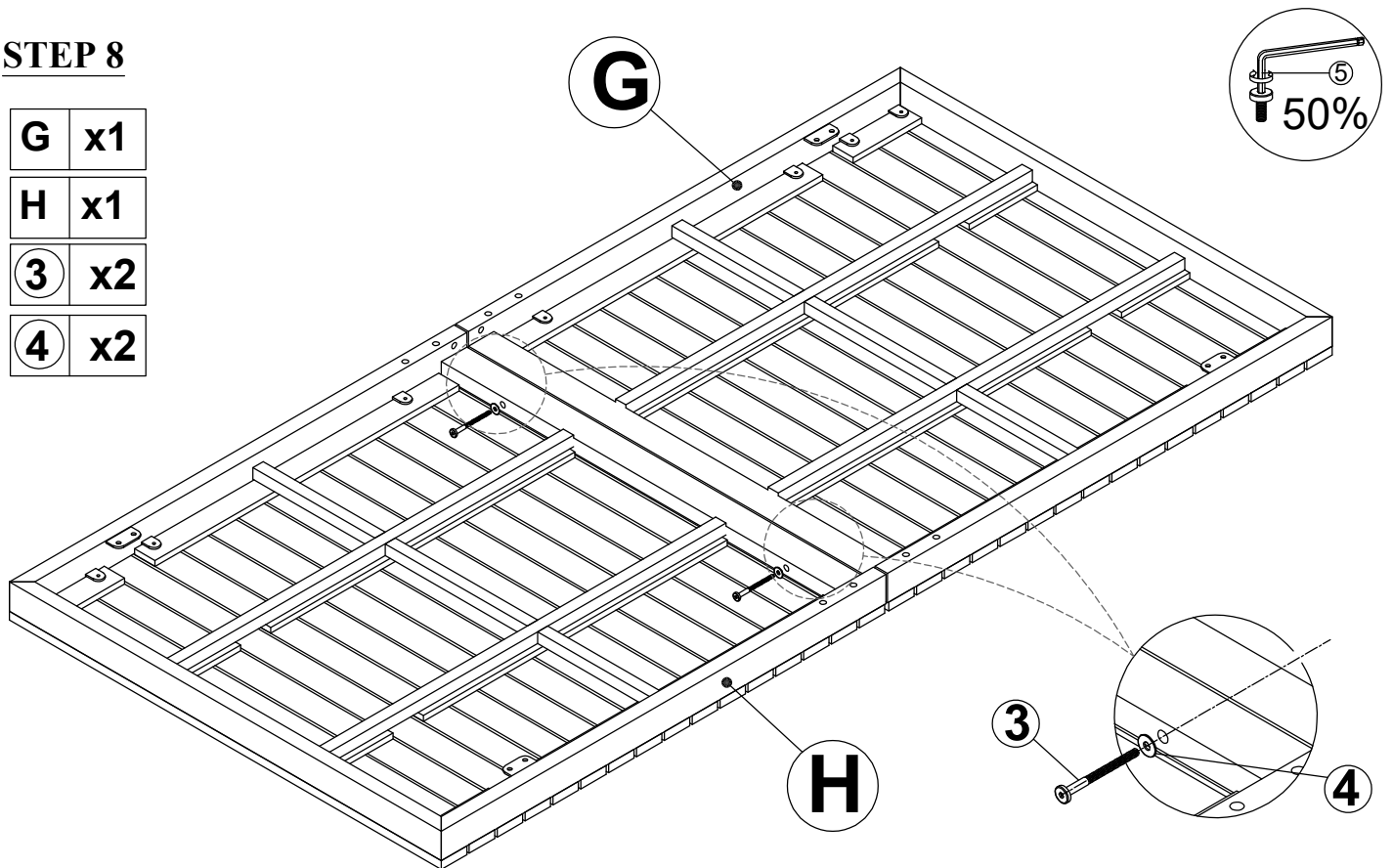

Connect Top Table (H) & Top Table (G), Tighten Bolt (3) & Flat Washer (4) with Allen Key (5).

### STEP 9

1 x12

4 x12

6 x2

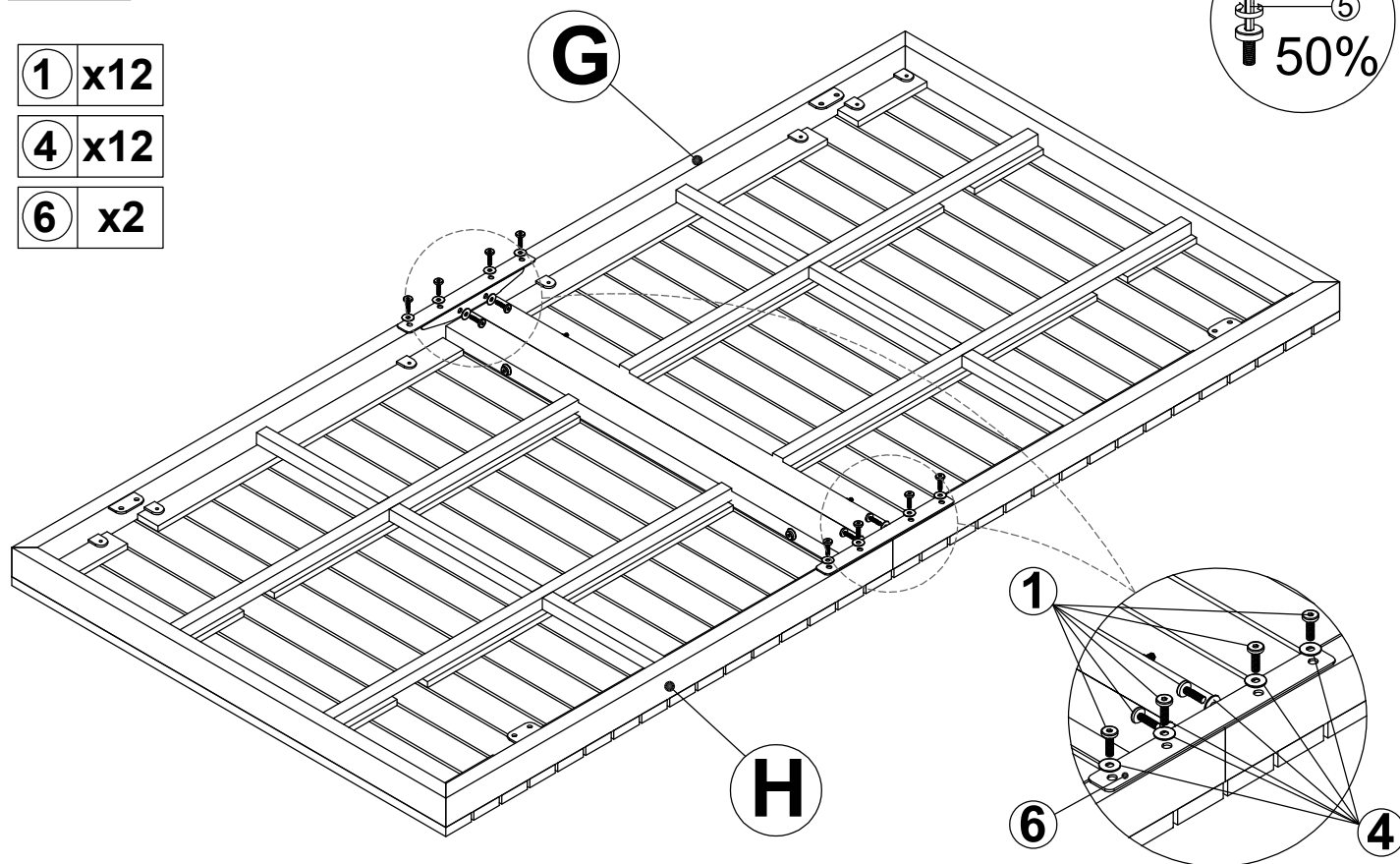
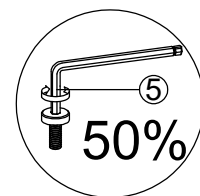

Connect the part from step 8 & Connector (6), Tighten Bolt (1) & Flat Washer (4) with Allen Key (5).

### STEP 10

I x2

1 x8

4 x8

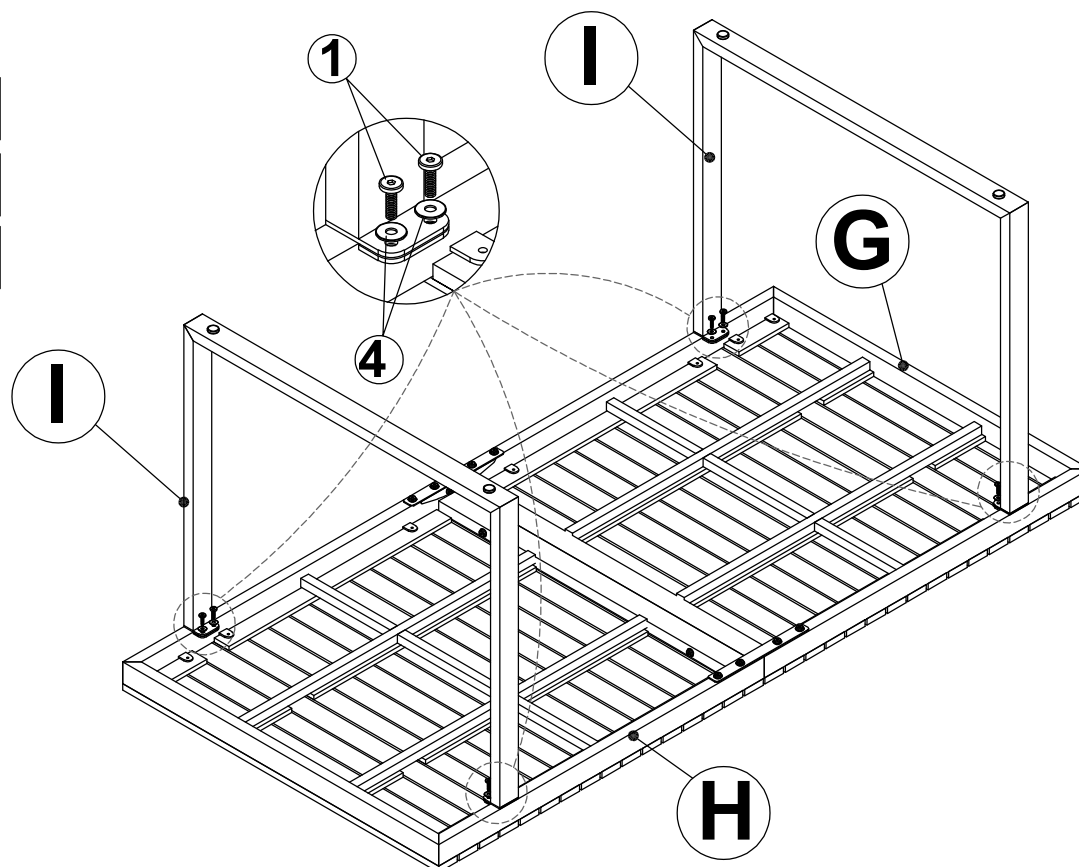
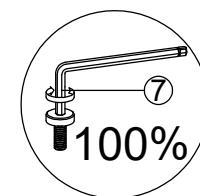

Connect the part from step 9, Table Leg ( I ), Tighten Bolt (1) & Flat Washer (4) with Allen Key (5).

**STEP 11**

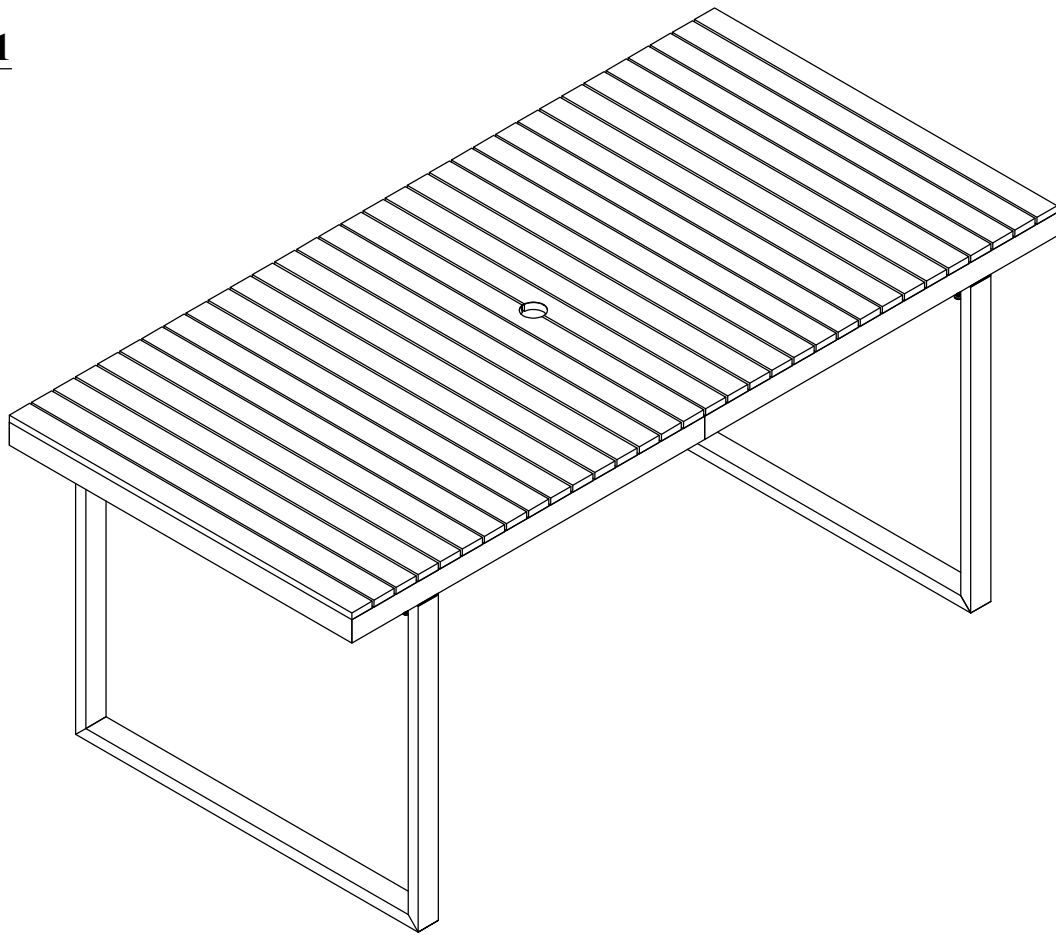

Finish Table

**STEP 12**

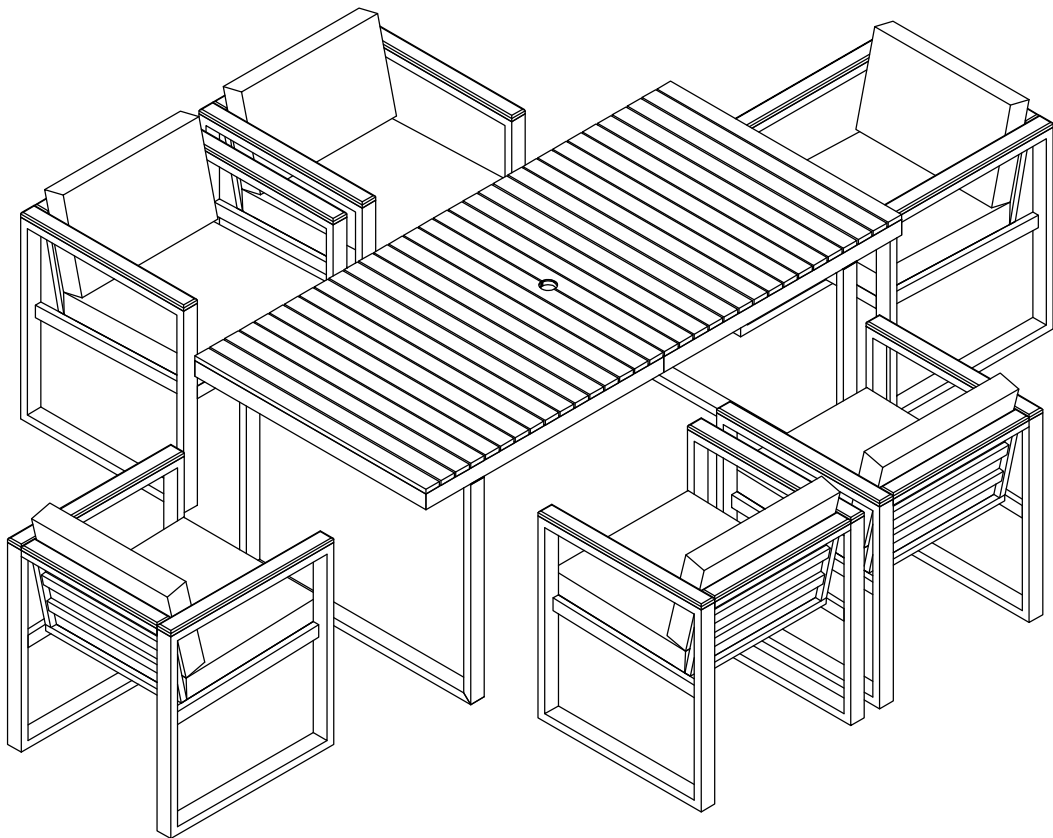

Finish.