

# ASSEMBLY INSTRUCTION

## DESCRIPTION: EASTERN KING BED

Thank you for purchasing this quality product. Be sure to check all packing materials carefully for small parts, which may have come loose inside the carton during shipment. Identify and count all parts and compare with the parts list below.

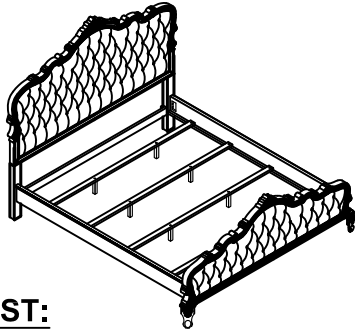

HARDWARE LIST			
NO.	Drawing	Description	Q'ty
A		Threaded Bolt (Ø5/16"x3-1/2")	8pcs
B		Flat washer (Ø5/16"x19mm)	8pcs
C		Spring washer (Ø5/16")	8pcs
D		Hex Nut (Ø5/16")	8pcs
E		Ø5/16" Wrench(12mm)	1pc
F		Wood screw Ø8x1-1/4"	8pcs

### PARTS LIST:

①	②	③	④	⑤
HEADBOARD: 1PC	FOOT BOARD: 1PC	SIDE RAIL: 2PCS	SLATS : 4PCS	SUPPOR LEGS : 8PCS

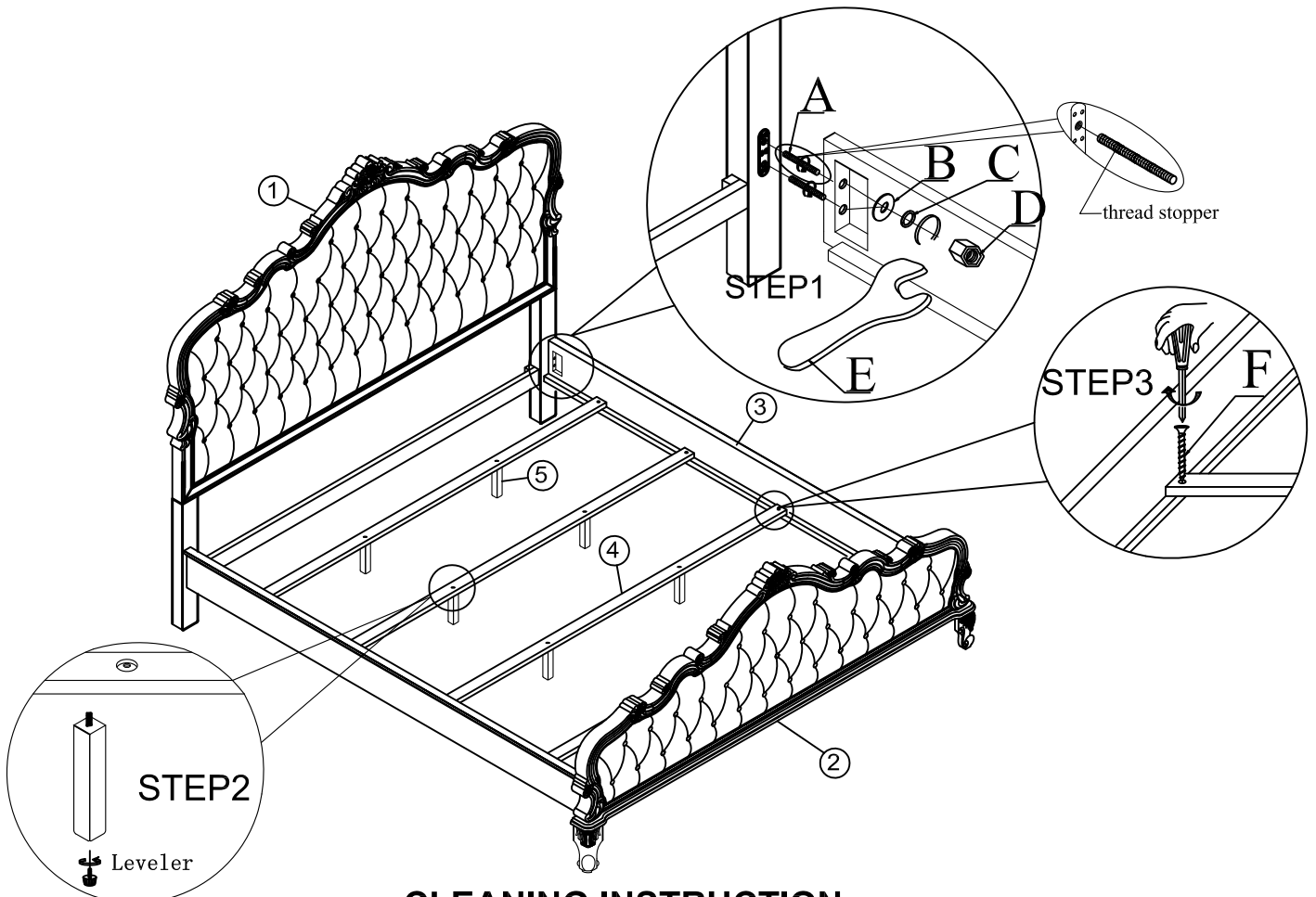

### CLEANING INSTRUCTION

Clean the Eastern king bed surface with a furniture polish and a soft cloth.

Made in VietNam