

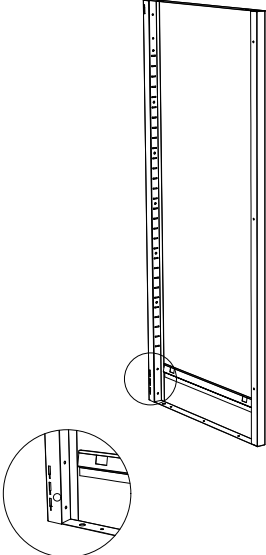

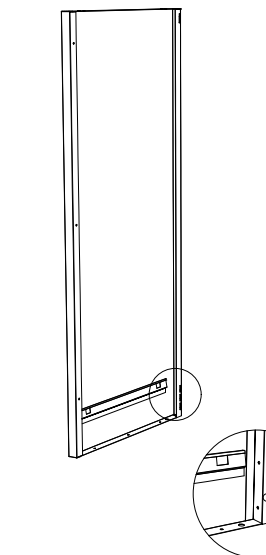

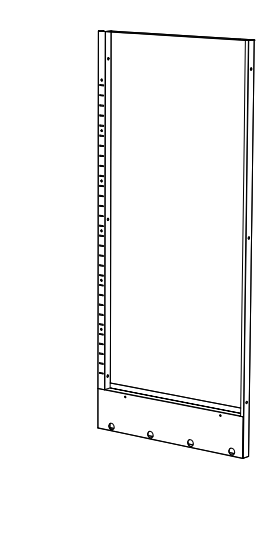

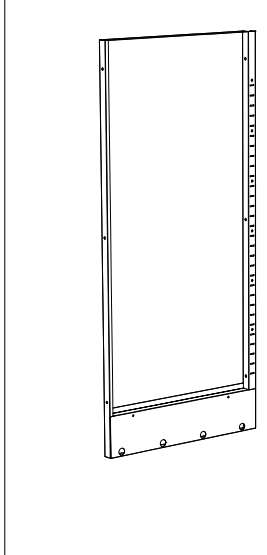

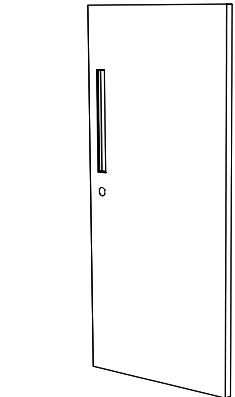
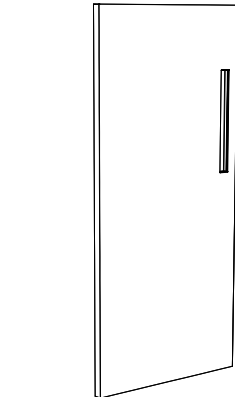
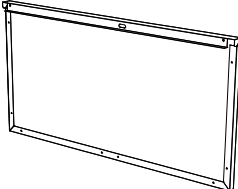
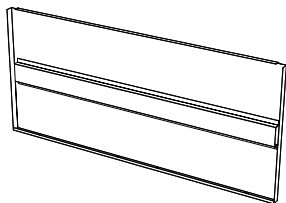



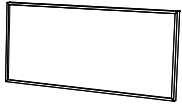

Installation video

A×1 		B×1 		C×1 		D×1 			
E×1 		F×1 		G×1 					
				H×1 					
I×1 		J×1 		K×2 		L×2 		U×2 	
M×40 	N×3 	O×3 	P×8 	Q×2 	R×4 	S×2 	T×2 Standby Application 		V×4 

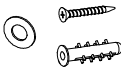

1

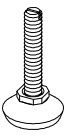
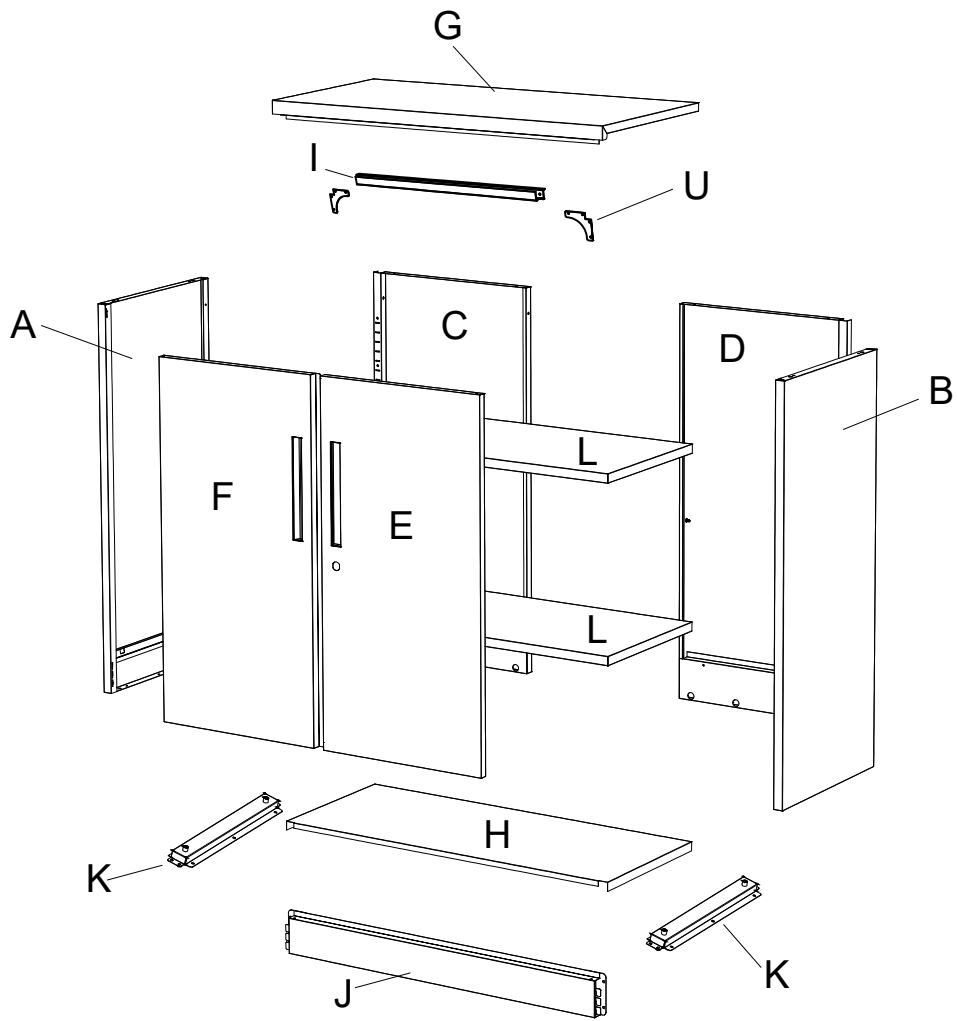
Put the two rear walls together and put four bolts and nuts to hold them in place.

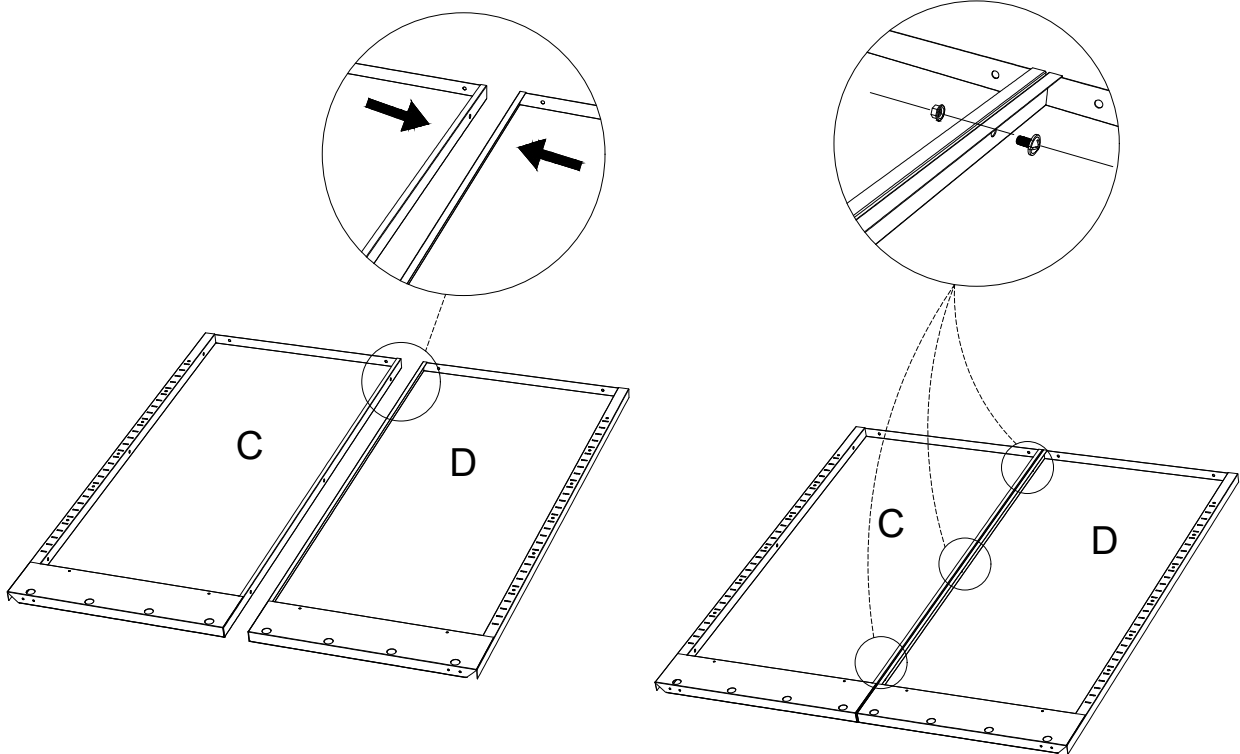

N×3

O×3

2

Simply overlap each sidewall in the channel of the rear wall and put three screws on each side to hold them in place. Note that Part A is on the left side and Part B is on the right side. If they are misplaced, it will affect the assembly

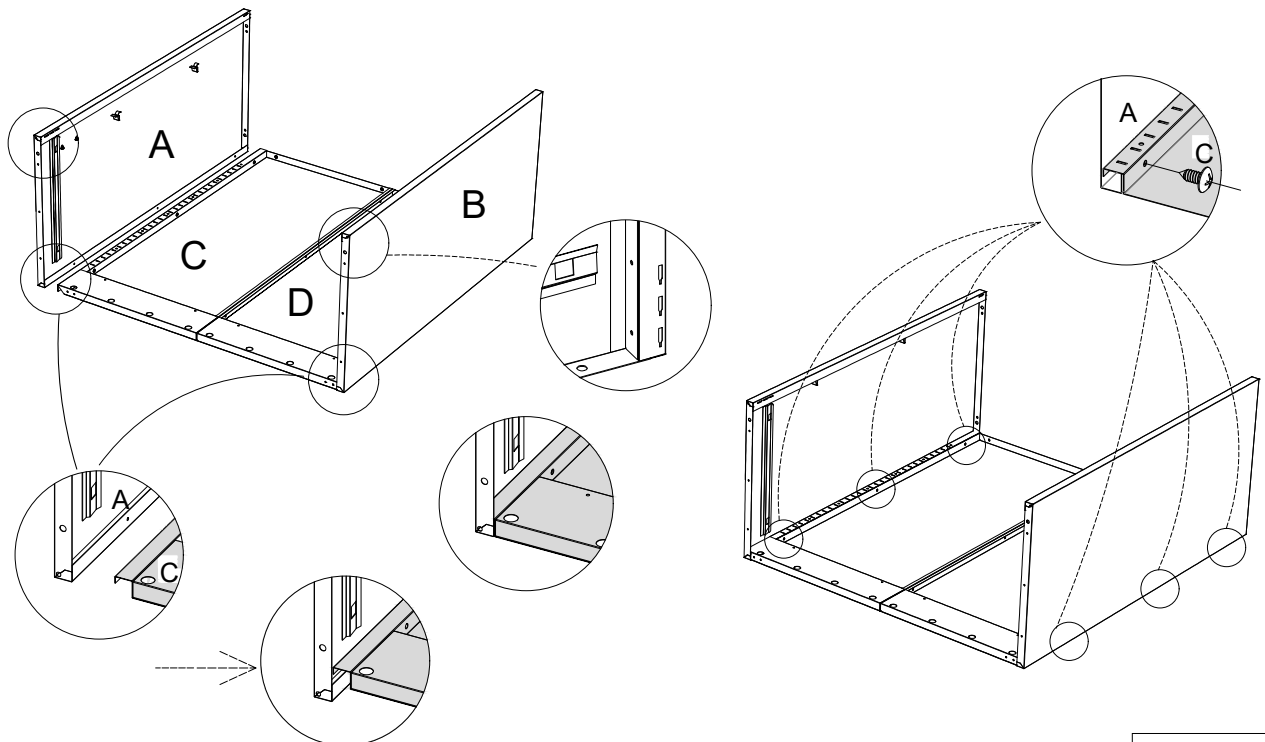

M×6

3

Snap the three buckles on either side of Part J into the three holes in both side panels and then push it down so that it snaps into the bottom of the cabinet.

Screw in four screws from the back of Part J (inside the cabinet).

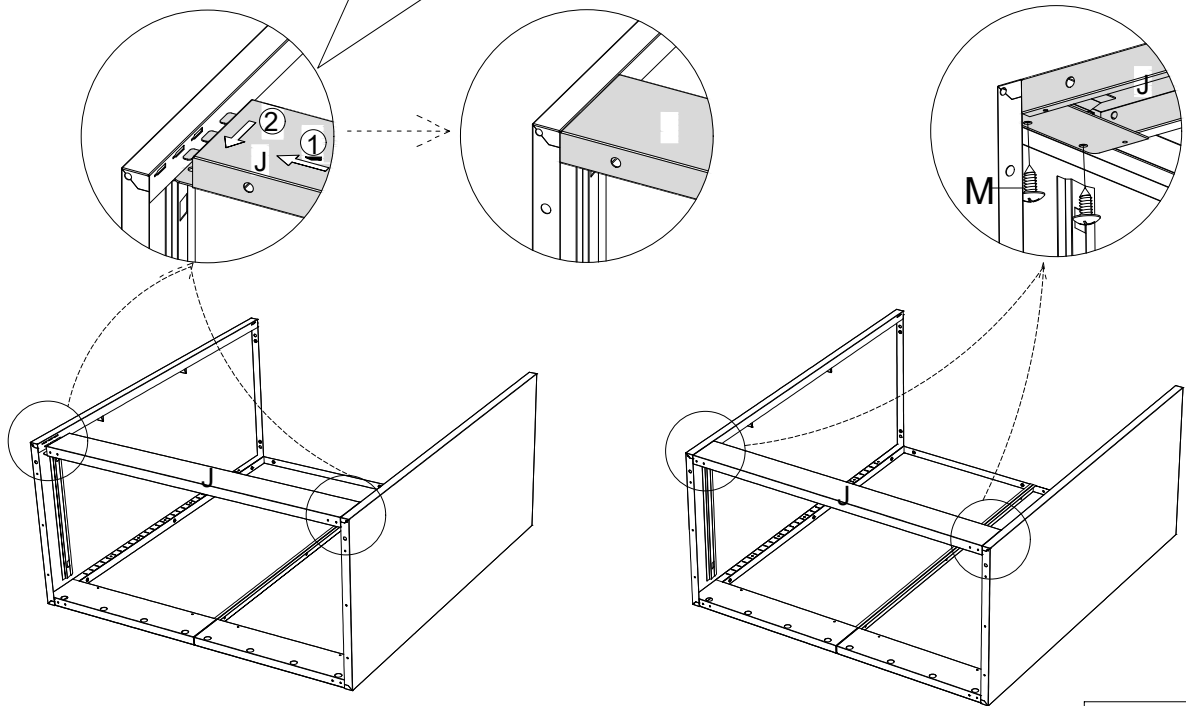

M×4

4

When placing Part H, place the notched side facing forward.

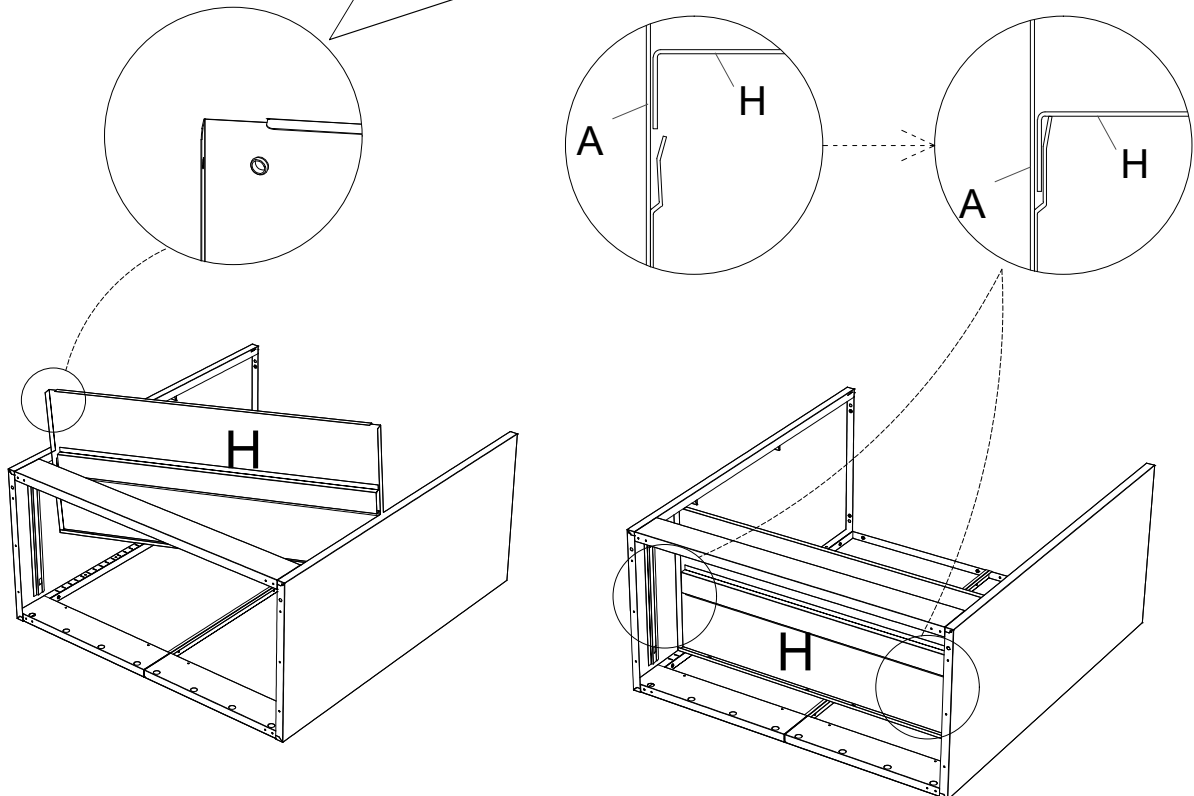

5

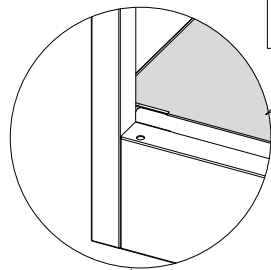

Note: No screws need to be put in the holes here.

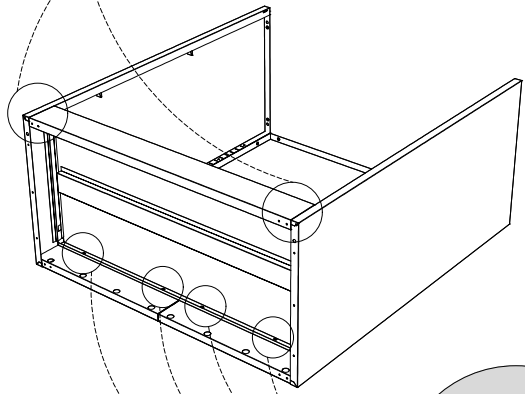

Align the holes on the back side of Part H with the holes located on the bottom of the back panel and secure them using the 4 screws.

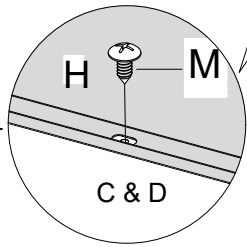

M×4

6

Align part U with the holes of parts A and B, then tighten the screws.

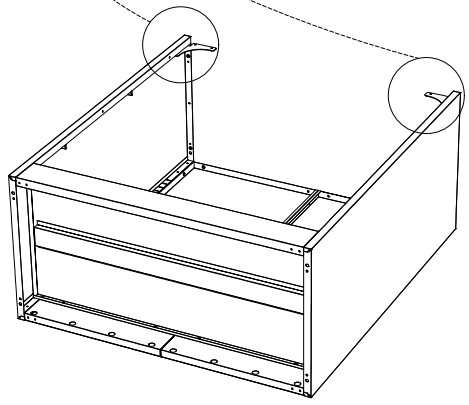
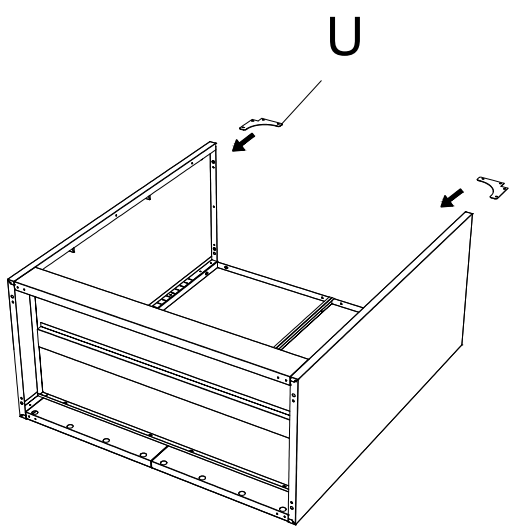
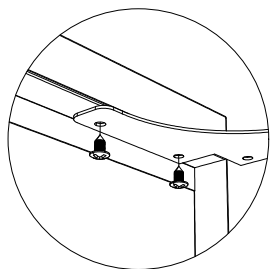
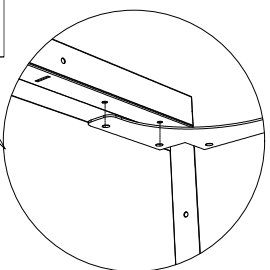

M×4

7

Align the hole of part U with part I, then tighten the screw.

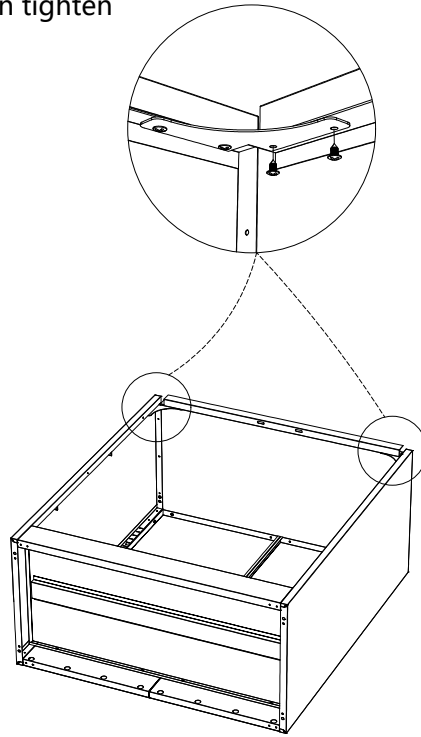
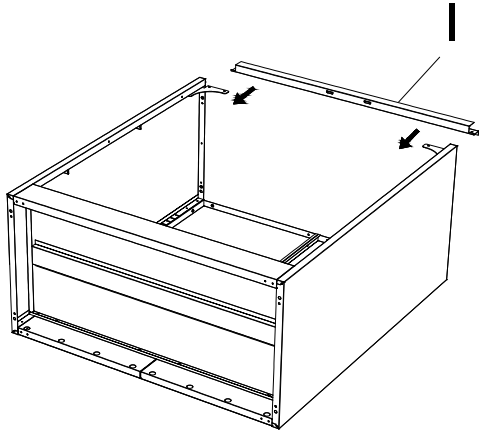

M×4

8

Align component G from above with the slots of components A and B, then snap it into place.

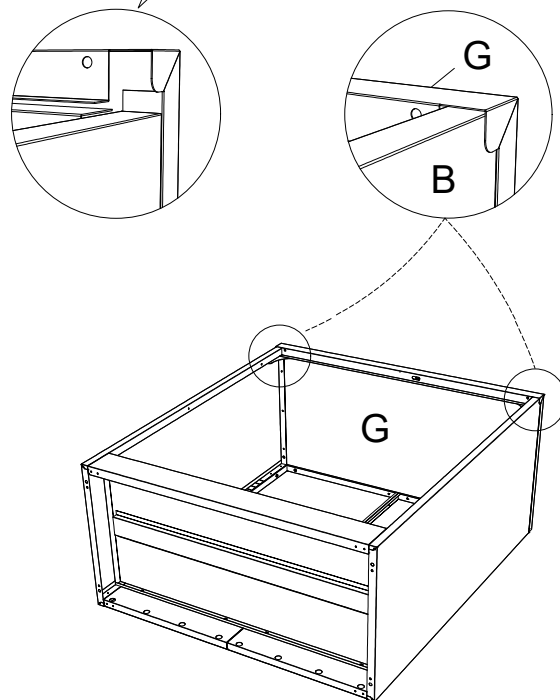
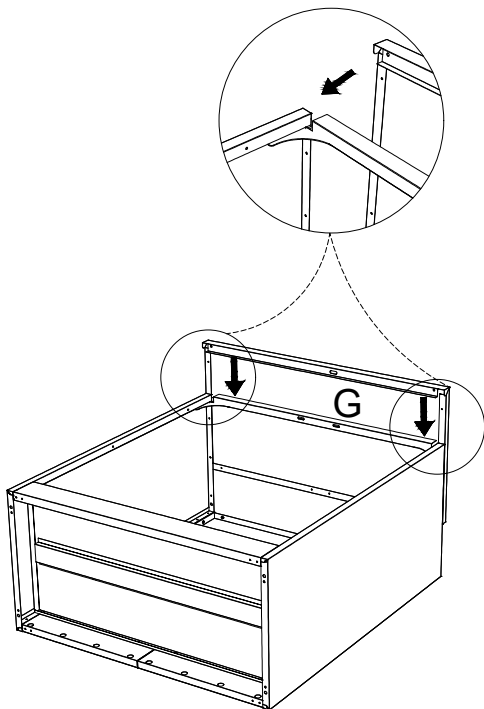

9

Align the holes of part G with parts A and B, then tighten the screws.

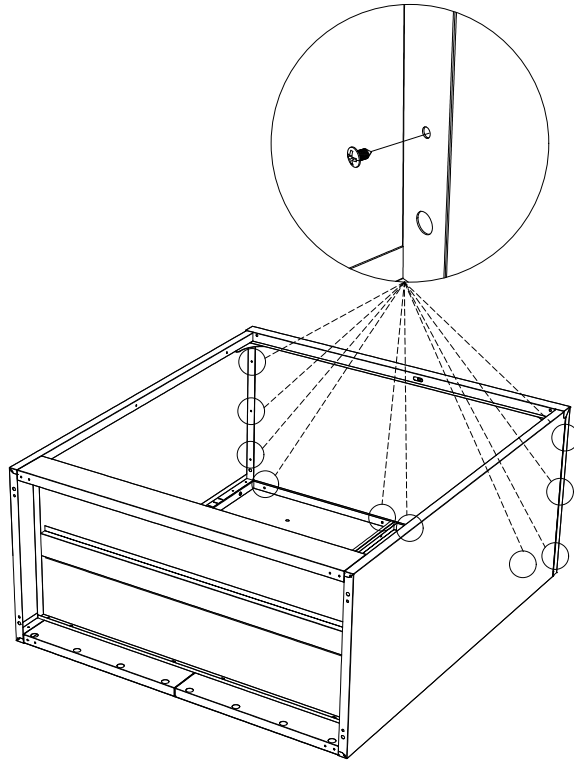

M×10

10

The raised gold hardware side on Part K faces the bottom of the cabinet.

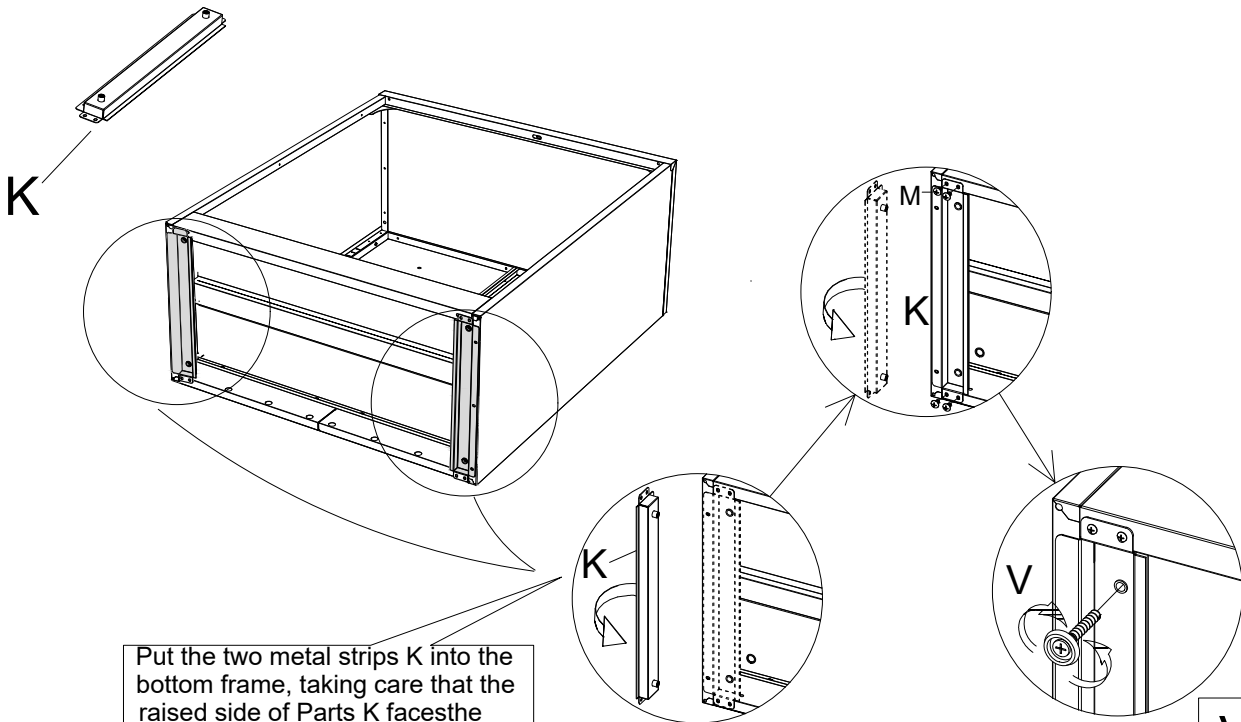

Put the two metal strips K into the bottom frame, taking care that the raised side of Parts K faces the inside of the cabinet and is flush with the bottom of the cabinet when assembled.

V×4

M×8

11

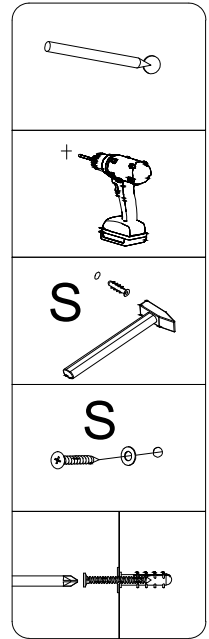
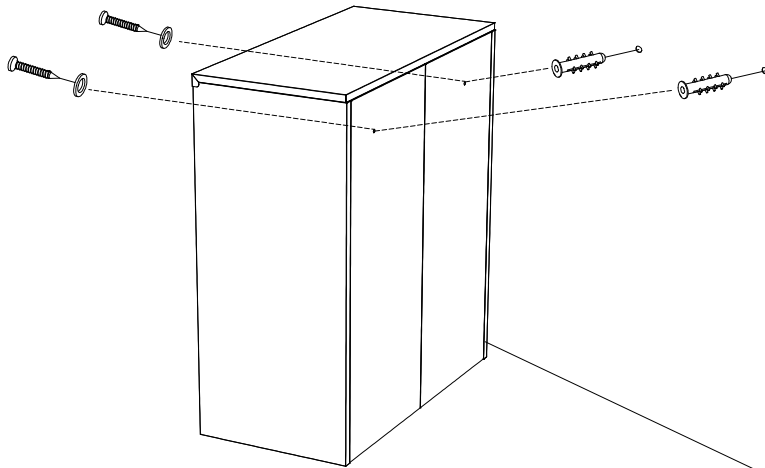

S×2

12

Put four support clips P in the four corners of the cabinet, taking care to place them on the same

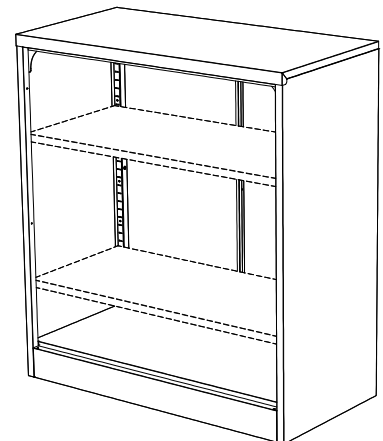
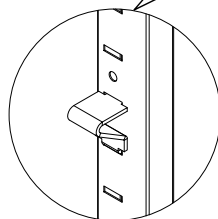
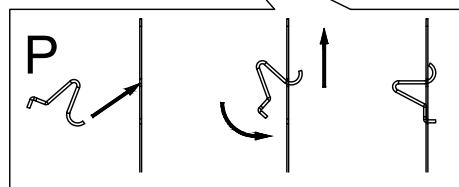
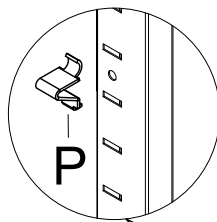
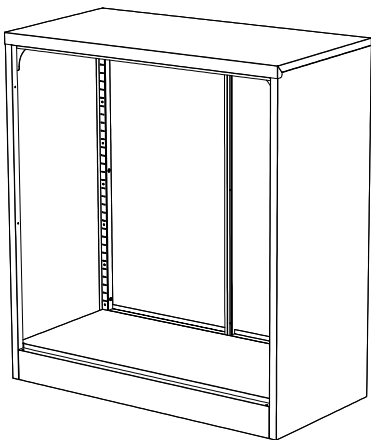

P×8

13

The horizontal height of each set of four support clips P can be adjusted according to the required height of the items to be placed.

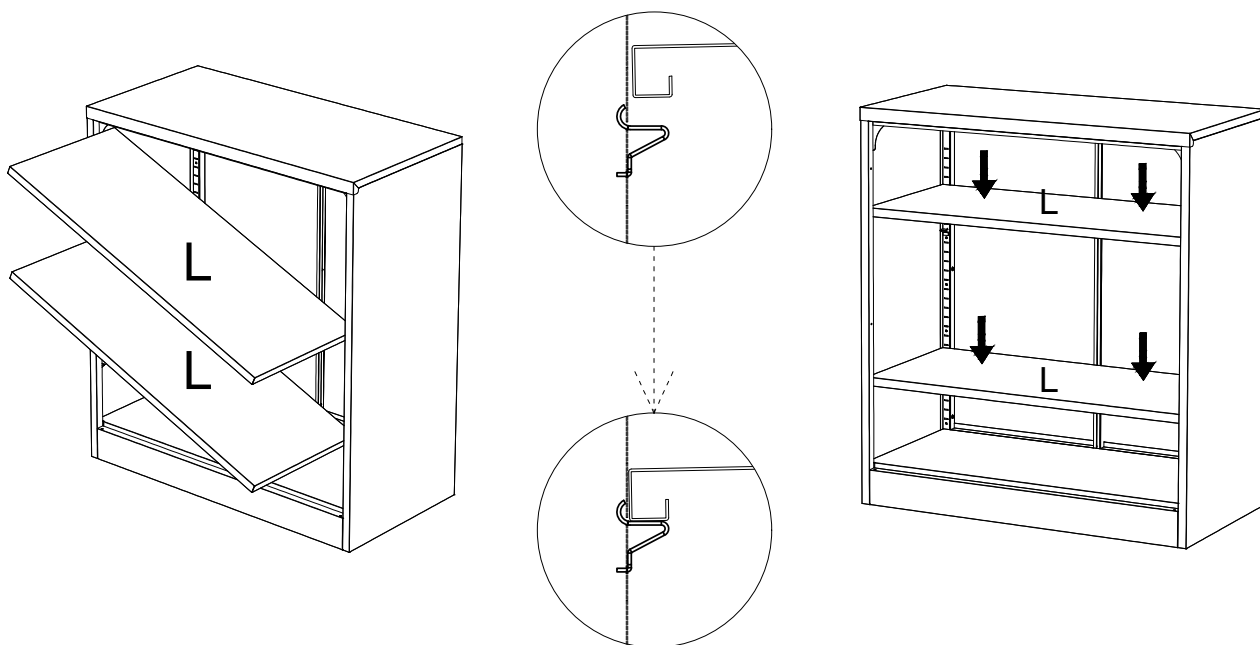

14

Install the door on one side by first installing the door shaft screw Q, then by pressing the spring screw on the top of the door.

If the spring shaft is lost, spare parts T can be used.

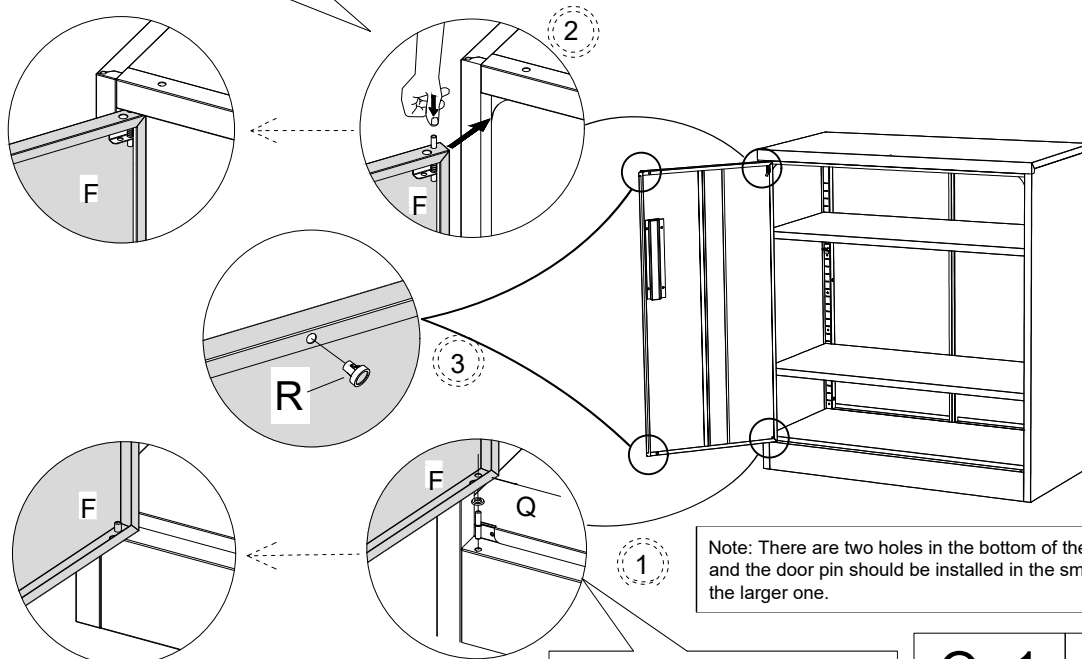

The door gap can be adjusted by increasing or decreasing the number of clear washers.

Q×1 R×2

15

Install the door by first installing the door pin Q, then by pressing the spring shafts on the top of the door.

If the spring shaft is lost, spare parts T can be used.

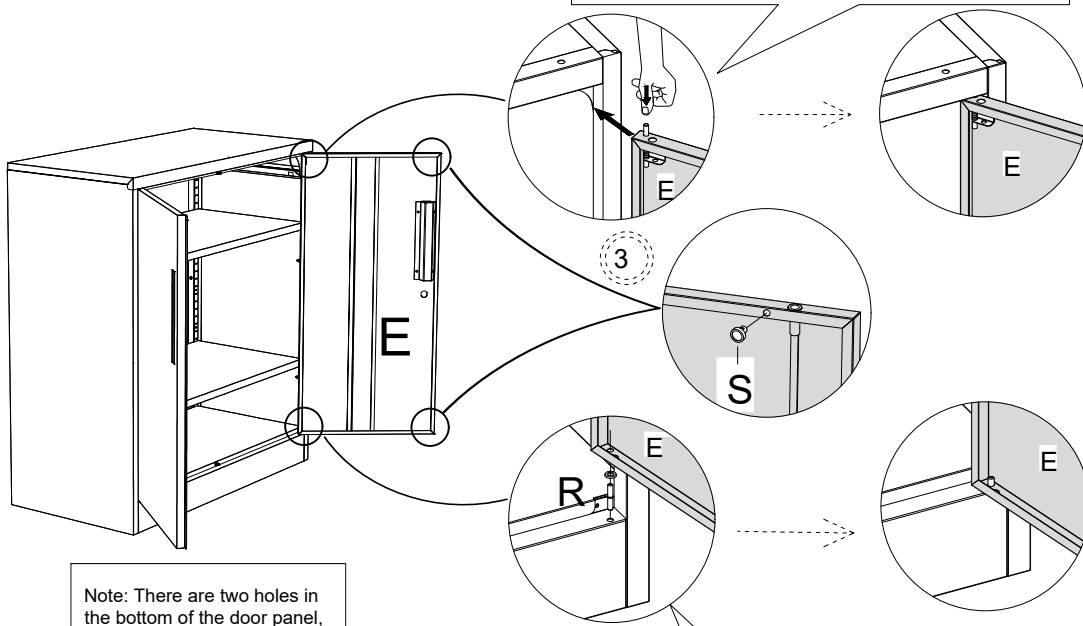

Note: There are two holes in the bottom of the door panel, and the door pin should be installed in the smaller hole, not the larger one.

The door gap can be adjusted by increasing or decreasing the number of clear washers.

Q×1	R×2
-----	-----

