



- Quality
- Value
- Service

**Tech
Reference**

Hygienic Solutions at Work

Baby Changing Station

Code 1125: Standard flip down change table

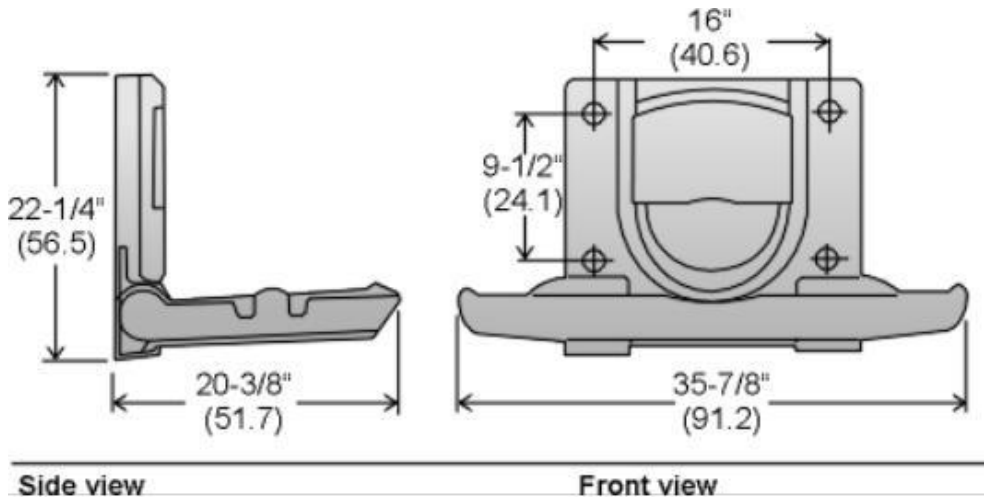

Specifications:

Site Location:

Frost Baby Changing Station with its four inch depth can be installed in any location.

Features: Static load capacity: 250 pounds (115 kg.). Four-inch depth complies with A.D.A. and ANSI A117.1 Handicapped accessibility. Oversized hinge and safety stop system. Safe and convenient sturdy child protection strap. Multilingual instructions, integral diaper bag hooks, easy opening and closing. Deep concave changing surface. Tamper proof hardware. Fully sealed polyethylene components allows easy cleaning. Smooth exposed surfaces and concealed pneumatic gas spring mechanism. Built-in Liner dispenser accepts standard multifold towels.

Materials: Constructed of 100% High-density polyethylene. No metal components to wear.

Unit dimensions: 36" (91.4cm)W x 22"(56.5cm)H x 4"(10.1cm)D, 20-1/2"(52cm) Deep when open. Mounting hole location template (and mounting hardware) included with each unit.

Description and specifications applicable on date issued. Frost reserves the right to make improvements or changes without notice.