

Swing Gate Opener User Manual

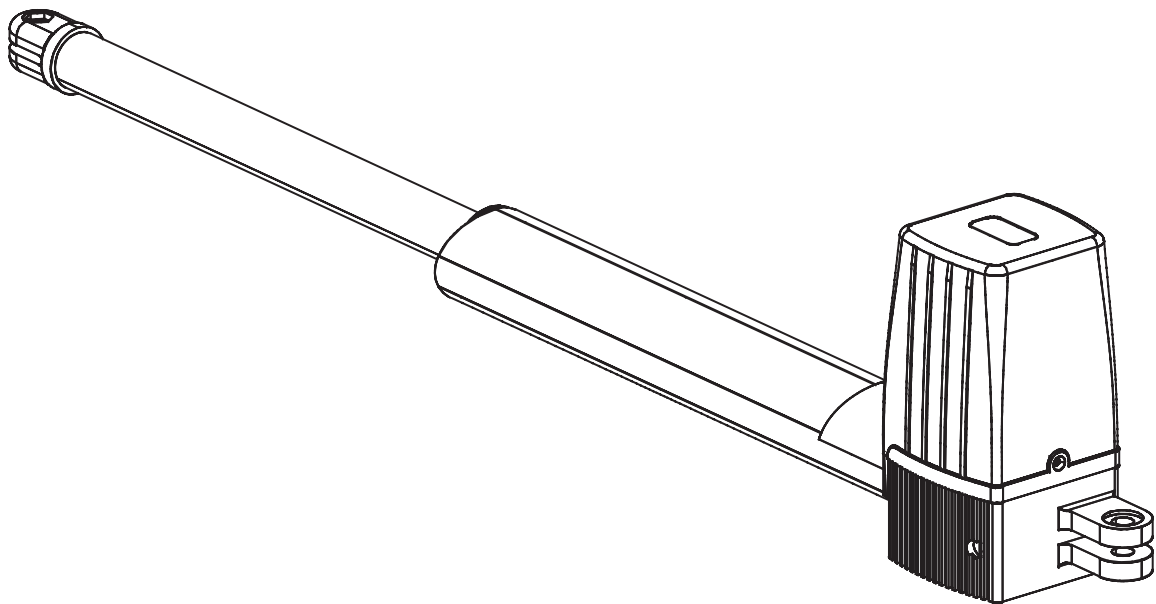

Read Carefully Before Use
Keep for Future Reference

1. Safety Information

Warning

General Safety

- Read these instructions completely before installation and use. Provide them to any technician used to install, maintain, or repair this device and provide them with the device if it is ever given or sold to a third party.
- Install and use this gate operator only in accordance with these instructions and all applicable local and national laws and regulations. Adding clearly visible warning signs may be necessary in your area and is a requirement for UL 325 compliance. Only use the device for its intended purpose, opening and closing gates for Class I residential vehicular traffic. Always aim to minimize public exposure to potential hazards such as pinch points. Failure to do so may result in serious property damage and severe personal injury.
- **ONLY** use this device for a gate intended for vehicular traffic. If pedestrian traffic is expected, it should be provided with a separate access point far enough away to ensure everyone on foot never comes into contact with the moving vehicular gate.
- **ONLY** use this device with gates of compatible weight and size.
- When properly configured and activated, the gate operator's collision reaction system functions as a Type A entrapment protection and an attentive user and the device remote function together as a Type B1 non-contact sensor. If any other access system is added, additional contact or non-contact sensors such as photo eyes, edge sensors, and/or infrared sensors may be necessary to ensure legal and UL 325 safety compliance.
- Install and use this operator only on firm and well-supported surfaces. Install and use this device so that its motor and other hazardous components are not in public areas and protected as much as possible from unauthorized access and use. There should be adequate clearance between your gate and any nearby structures to prevent any possibility of a pinching or crushing hazard during use. If this is impossible, the area should be guarded as well as possible and warnings placed nearby.
- Confirm **BEFORE** any digging that there are no nearby gas, power, or other utility lines or that all such lines have been fully disabled and cleared to allow for safe work.
- **DO NOT** install this device in any area prone to flooding or in locations exposed to flammable or explosive fumes.
- **ONLY** install fixed controls for the gate where they cannot be reached over, under, around, or through the gate. They should also be far enough away that operators cannot contact the moving gate during use. For full UL 325 compliance, there should be a clear line of sight between the control box and the gate, but the box and any other permanent access system should still be at least 6 feet (2 m) away from any of the gate's moving parts.

Electric Safety

- Use a dedicated circuit breaker for the gate opener. The circuit breaker should be located out of the reach from outside your property and 5 feet (1.5 m) above the ground. Shelter the circuit breaker from the weather elements.
- **ONLY** allow trained technicians to install and repair this automatic gate operator and its electrical connections. Keep electronic components disconnected from any power source during installation and maintenance except as instructed for safely testing functionality.
- The control box and the actuator have no preinstalled power cords. **ONLY** use cords with 3 cores and a minimum cross-section of 1.5 mm² (approx. AWG 15).

- Provide robust protection for the control box power cable. Use PVC conduit or other similarly sturdy material.
- **NEVER** allow children to play on or around this device or its attached gate. Keep controls away from children and out of their reach at all times and warn them of the gate's danger.
- **NEVER** pair a remote control for this device with any other control board. Never attempt to operate this device with two or more remotes or control devices at the same time.
- All provided components of this device are weatherproofed to withstand normal rain. Ensure adequate insulation and protection of all electrical connections and never direct pressurized water against any part of this device.







Maintenance Safety

- Never check or clean the piston of the actuator when it is connected to power. Keep your gate well maintained and the device's piston(s) free of grime and debris. Periodically confirm that it runs smoothly under manual operation.
- **DO NOT** use if any component is missing, loose, worn, or damaged. Tighten, repair, or replace problematic parts before further use. Only replace components with identical parts and always fully replace damaged electrical cords.

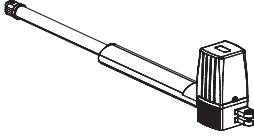
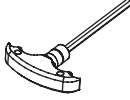
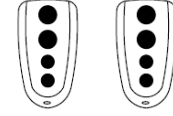
2. Specifications

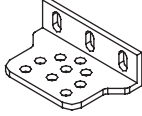
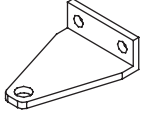
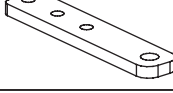
| | | |
|-------------------------------------|--------------------|---------------|
| Model | PK300DC | |
| Voltage | 110 V/60 Hz | |
| Power | 80 W | |
| Est. Time to Open/Close 90° | 18–22 (sec.) | |
| Gate Open Delay | 0–10 (sec.) | |
| Gate Close Delay | 0/15/30/60/90 sec. | |
| Duty Cycle | S2 30 min. | |
| Max. Single-Leaf Gate Weight | 650 lb. | 300 kg |
| Max. Single-Leaf Gate Length | 9'10" | 3 m |
| Actuator Max. Stroke | 13.8" | 35 cm |
| Max. Force(ea.) | 337.5 lbf | 1500 N |
| Max. Remote Control Range | 98.4 ft. | 30 m |
| Max. Noise | 58 dB | |
| Max. Remote Pairs | 32 | |
| Frequency | 433.92 MHz | |
| Working Temperature | -4°F to 158°F | -20°C to 70°C |
| Weatherproofing | IP44 | |
| Net Weight | 37.7 lb. | 17.1 kg |

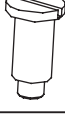
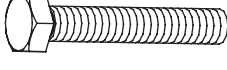
2.1 Package List (Standard)

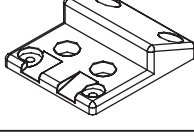
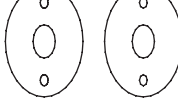
| No. | Illustrations | Items | Qty. |
|-----|---|----------------------------|------|
| A |  | Actuators | 2 |
| B |  | Manual Release Key | 1 |
| C |  | Remote Controls | 2 |
| D |  | Control Box with Casing | 1 |
| E |  | Post Brackets | 4 |
| F |  | Gate Brackets | 2 |
| G |  | Post Pivot Brackets | 2 |
| H |  | Actuator Tip Bolts (short) | 2 |
| I |  | Actuator End Bolts (long) | 2 |
| J |  | Screw M8×25 | 4 |
| K |  | Nut M8 | 8 |
| L |  | Limit Stop | 1 |
| M |  | Wired Photocells | 1 |

3. Installation

Overview

Push-to-Open

Refer to the diagram above for where things should be. Note that there are two ways to install the actuators: push-to-open and pull-to-open. Each way only works properly with the limit stop properly installed (L).

- ① Control Box
- ② Actuator
- ③ Gate
- ④ Alarm Lamp
- ⑤ IR Sensor (Optional)
- ⑥ Limit Stop
- ⑦ Remote Control
- ⑧ Keypad (Optional)

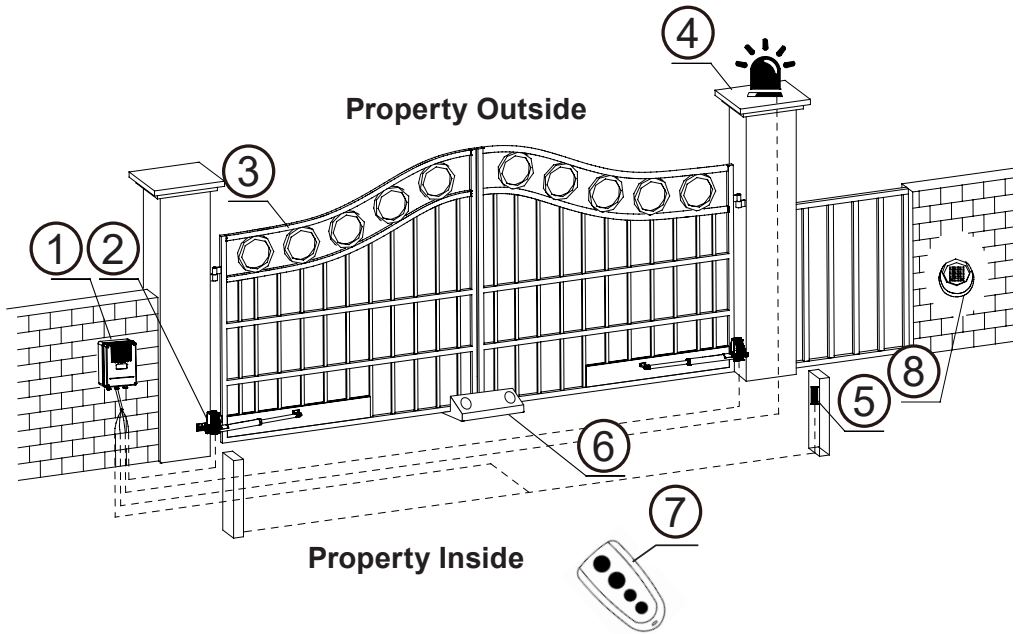

Pull-to-Open

- ① Control Box
- ② Actuator
- ③ Gate
- ④ Alarm Lamp
- ⑤ IR Sensor (Optional)
- ⑥ Limit Stop
- ⑦ Remote Control
- ⑧ Keypad (Optional)

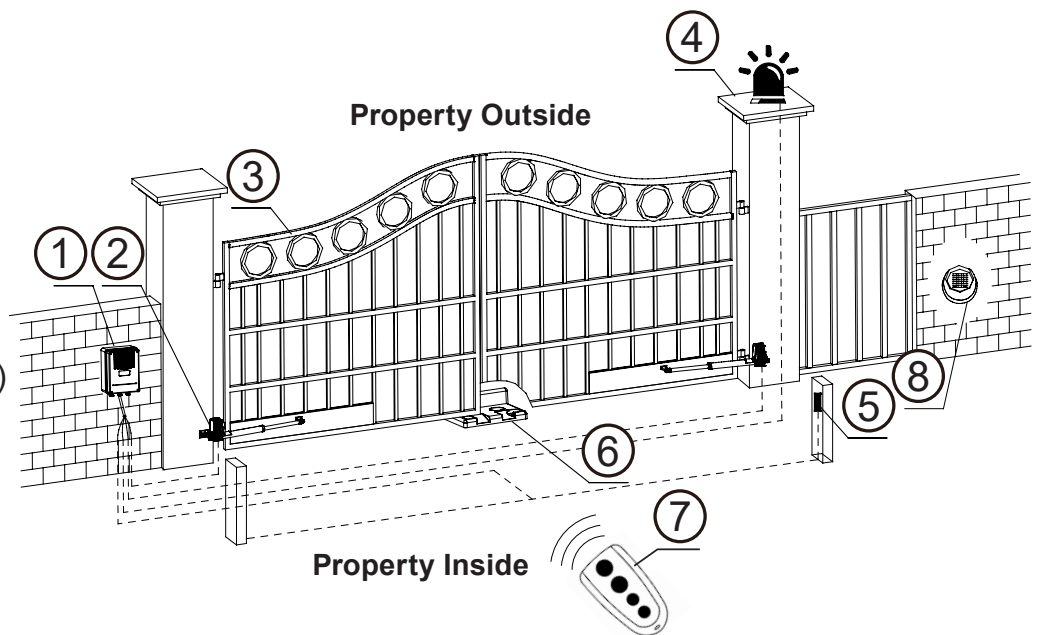

Installation Preparation

Required Tools

- Power Drill/Hammer Drill
- M8 Drill Bits
- M8 Bolts & Nuts× 4⁽¹⁾
- M8 Expansion Bolts & Nuts× 8⁽²⁾
- Tape Measure
- Adjustable Wrenches
- Wire Strippers
- Spirit Level
- Hacksaw or Heavy-Duty Bolt Cutters
- Phillips Screwdriver
- Pickaxe
- PVC Conduits
- Marker

(1) Length of the bolts depends on the exact thickness of the gate beam to which you will attach the gates brackets.

(2) Length of the expansion bolts depends on the exact thickness of the posts to which you will attach the post brackets.

Pre-installation Check

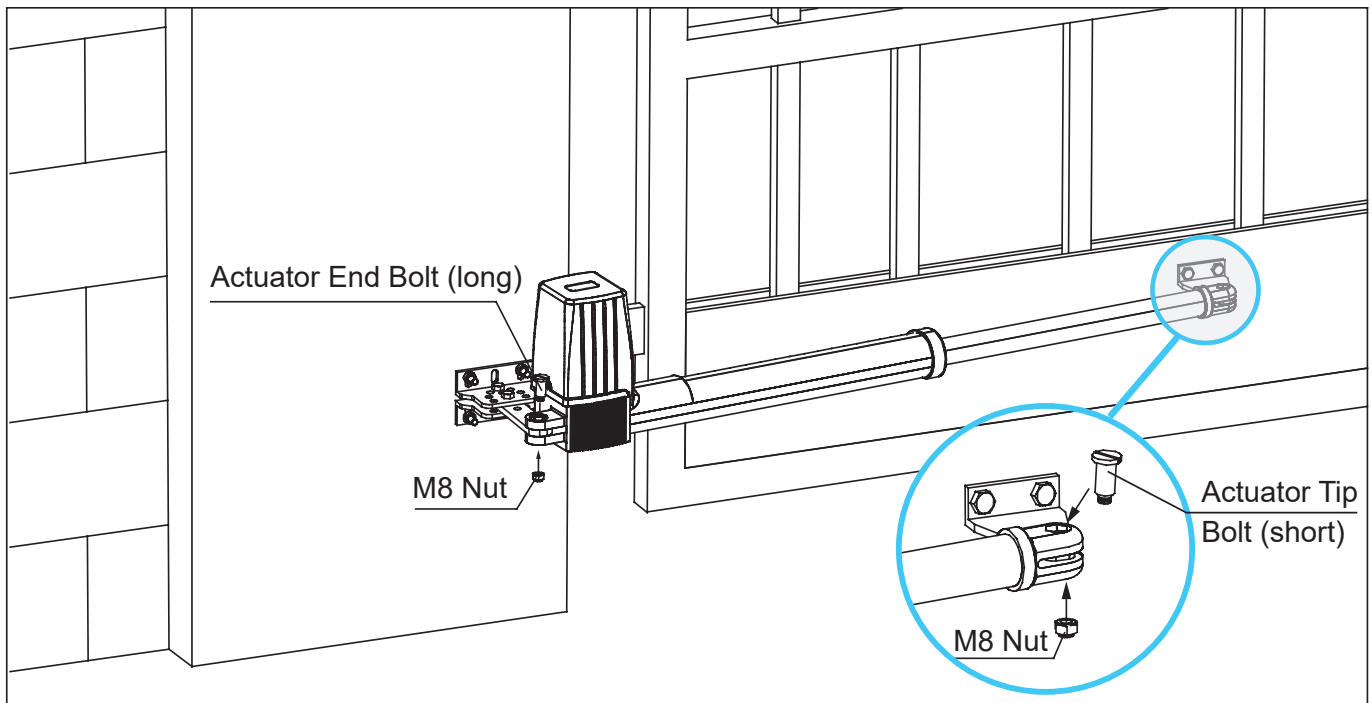

Referring to the diagram above, check that:

- Both your gate leaves have a horizontal beam sturdy enough to bear the push and pull of the actuator. Ideally the beam should be metal or solid wood at least.
- The post on which the gate is mounted has a sturdy structure and provides drillable surface facing the inside of your property.
- Both beams are about 11.8–31.5 inches (300–800mm) above the ground.
- Your gate is plumb and level both vertically and horizontally. Confirm that it swings smoothly on its hinges throughout its full range of motion without any binding or contact with the ground. Confirm that its posts are firmly secured in concrete and that the gate itself will not bend or flex once its movement is automated. Lubricate, repair, and reinforce the gate's components as needed.
- All of the hinges' fasteners are securely fixed to the post or wall. Reinforce as needed.
- The ground on which the limit stops will be installed is firm enough to withstand the moving weight of the gate.
- Your automatic gate operator will be able to provide the necessary torque using the chart below.

| Max. Single-Leaf Weight | Gate Capacity | | | | | |
|-------------------------|------------------|------------------|------------------|-----------------|-------------------|-------------------|
| | 5 ft. (1.5 m) | 6 ft. (1.8 m) | 8 ft. (2.5 m) | 10 ft. (3 m) | 12 ft. (3.6 m) | 14 ft. (4.3 m) |
| 660 lb. (300 kg) | ✓ | ✓ | ✓ | | | |
| 550 lb. (250 kg) | ✓ | ✓ | ✓ | ✓ | | |
| 440 lb. (200 kg) | ✓ | ✓ | ✓ | ✓ | | |
| 330 lb. (150 kg) | ✓ | ✓ | ✓ | ✓ | ✓ | |
| 220 lb. (100 kg) | ✓ | ✓ | ✓ | ✓ | ✓ | ✓ |
| 150 lb. (70 kg) | ✓ | ✓ | ✓ | ✓ | ✓ | ✓ |
| 100 lb. (50 kg) | ✓ | ✓ | ✓ | ✓ | ✓ | ✓ |

- If you will use an electronic lock with your gate, make any necessary adjustments so that the two sides connected by the lock are spaced $\frac{5}{8}$ to $\frac{3}{4}$ inch (1.5–2 cm) apart. (If you will not use an automated electronic lock, any range should be fine.)

Actuator Positioning

1. Unlock the actuator.
 - a) Fetch the manual release key (9) to each actuator.
 - b) insert it to the key hole on its corresponding actuator.
 - c) turn the key the way as shown below.

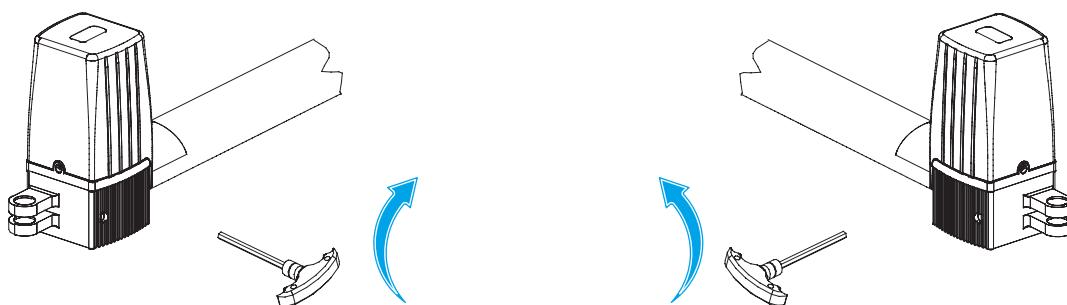

2. Determine the mounting positions and for the post brackets and gates bracket referring to the diagrams below, which show the maximum opening angle for a given horizontal (B) and vertical (A) distance between bracket joints and gates in millimeters.

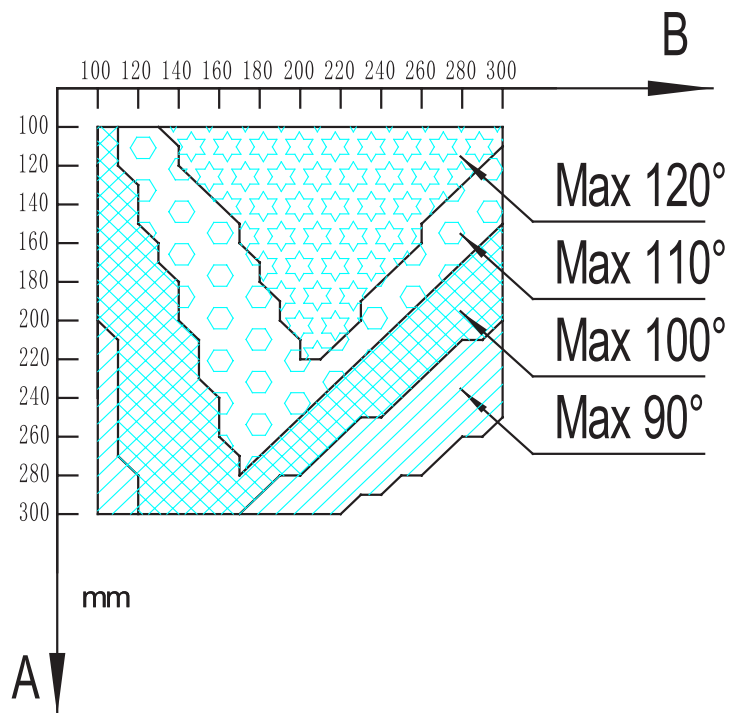
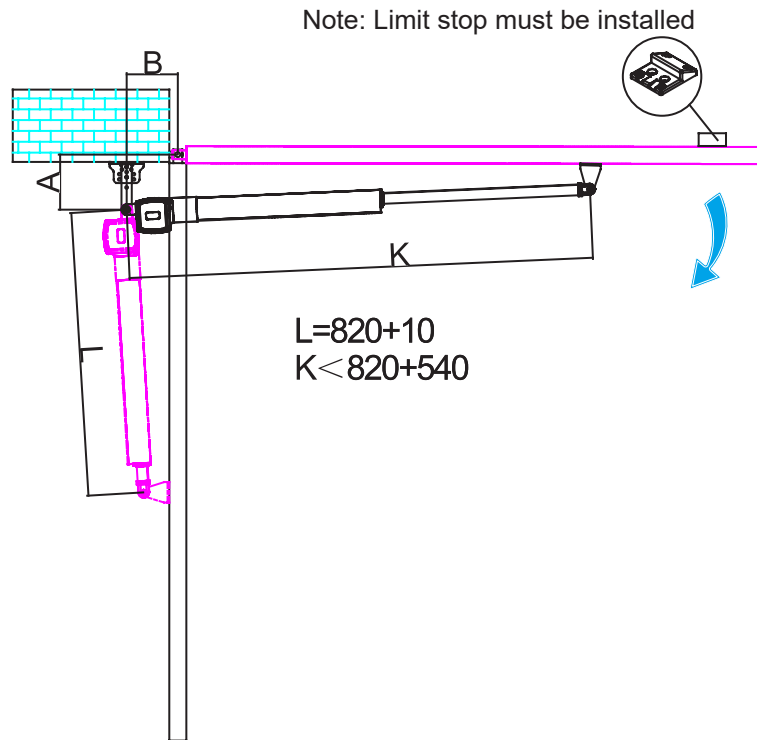

This limit stop is not included.
Purchase one that can handle
the weight of your gate.

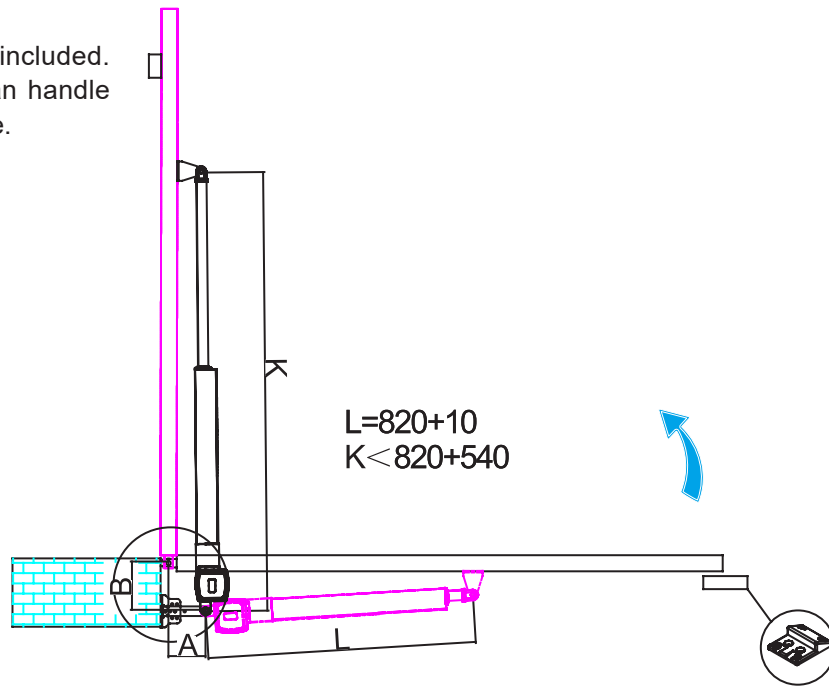

Note: Limit stop must be installed

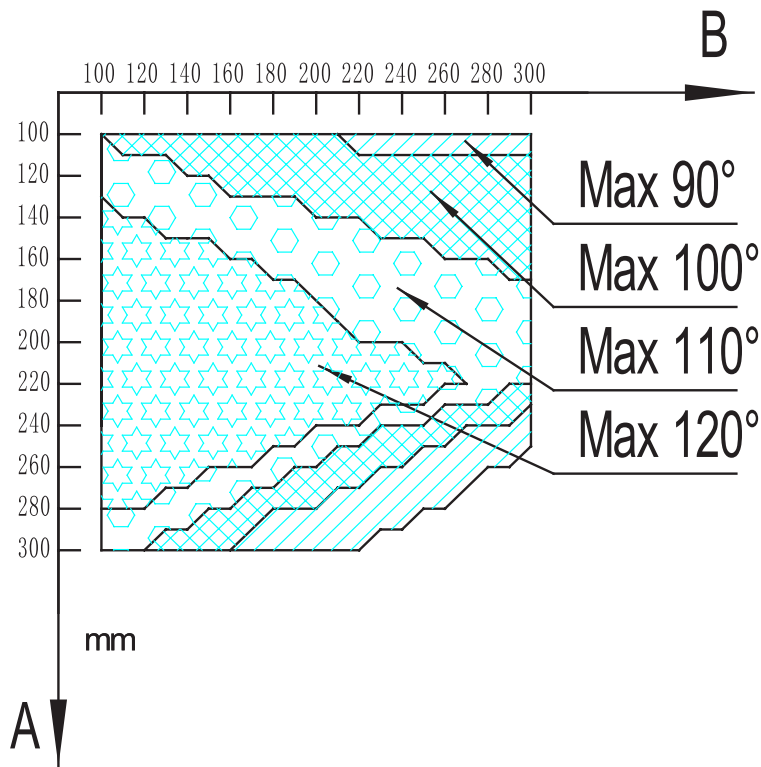

Note that the post pivot bracket can be installed in the following fashion. Choose one that works with your specific gates and post.

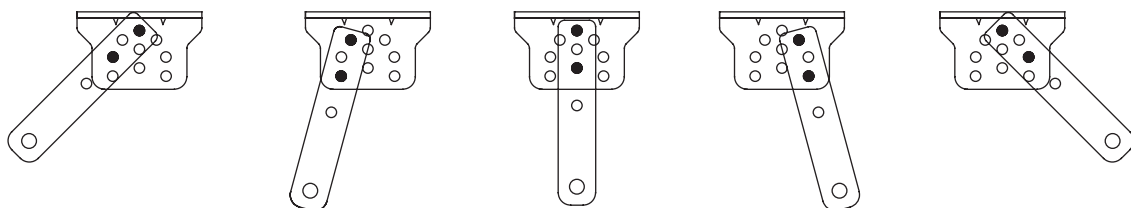

3. Mark the positions of the post brackets and gate brackets on the post and gate beam using your marker (not included).
4. Repeat Step 2–3 for the other actuator.

Positioning the Brackets

1. Press the gate brackets on the beam and the post brackets referring to the marks you have made above.
2. Again, using your marker, mark the positions of the bracket's hole on the gate and post. Refer to the bracket specifications for quick marking.

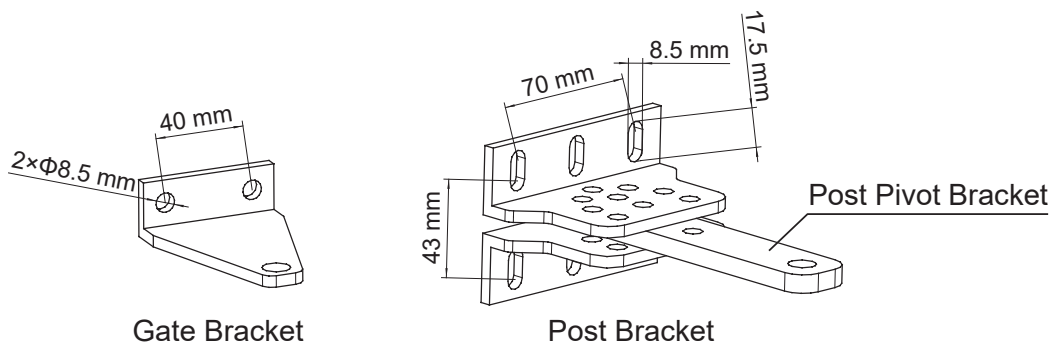

Caution

Use the four diagonal holes on the two post brackets.

Installing the Brackets

Caution

Do not use hammer drills on wooden posts, which could crack easily upon the impact of such drill. Instead, use drills and M8 bolts long enough to impale the post

1. Drill a hole at each mark that you made for the post brackets using a power drill or hammer drill (not included), depending on the exact material of the post.
2. Bolt the post brackets to the post the way as shown using your adjustable wrench and the M8 expansion bolts or regular bolts long enough to pass through the whole thickness of the post.
3. Insert the post pivot bracket into the two post brackets and fastening it in place with 2 of the provided M8 bolts and nuts (J & K).

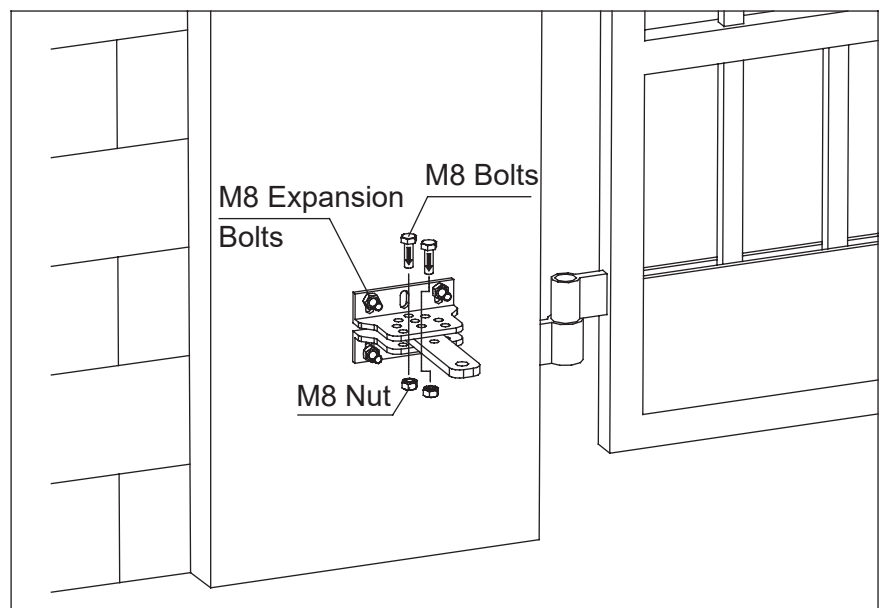

4. Drill a hole through each mark that you made for the gate bracket using a power drill.
5. Bolt the gate bracket to the gate using your regular M8 bolts and adjustable wrench.
6. Repeat Step 1–5 for the other gate bracket and post brackets.

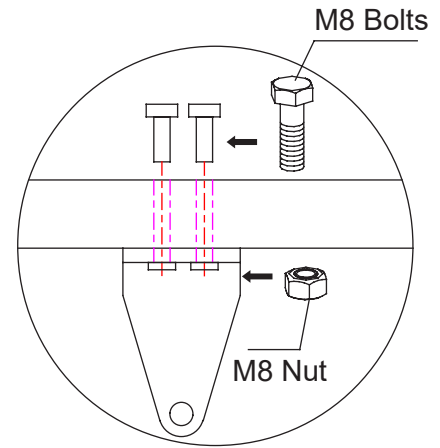

Mounting the Actuators

1. Mount one actuator to the gate bracket and post brackets the way as shown.
2. Repeat Step 1 for the other actuator.

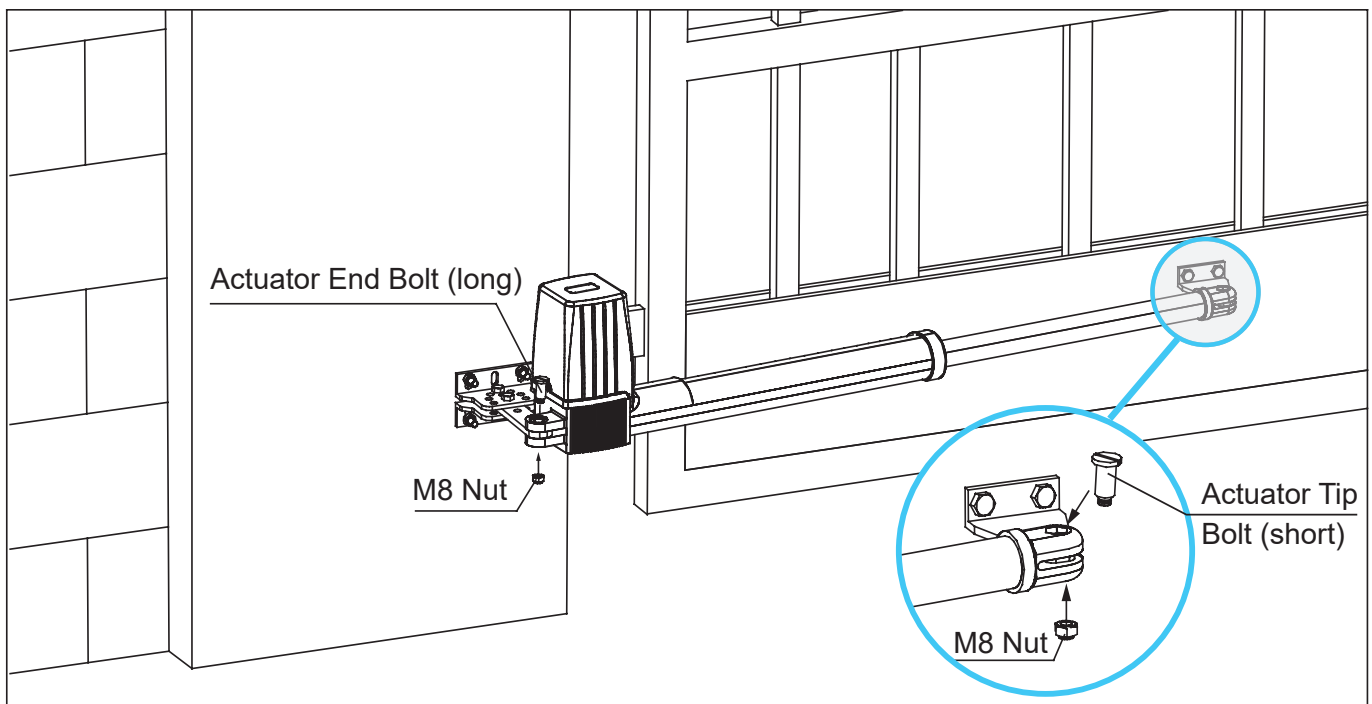

Installing the Limit Stops

For Push-to-Open installation, refer to the diagram below for where the limit stop should be installed.

This limit stop is not included.
Purchase one that can handle
the weight of your gate.

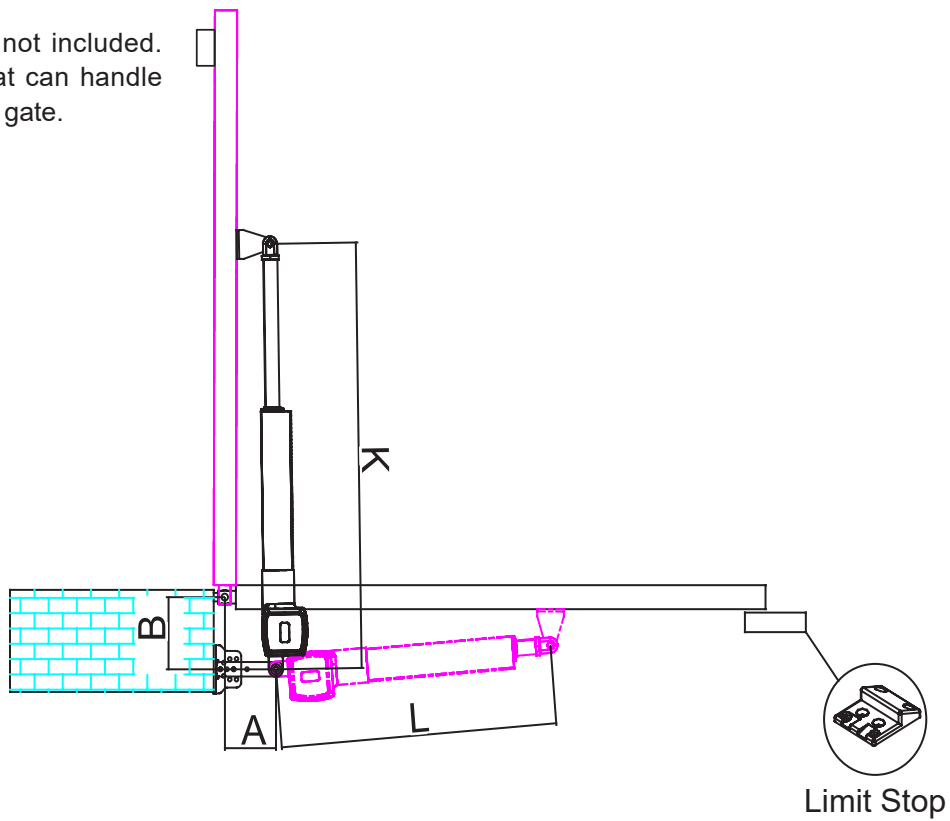

For Pull-to-Open installation, refer to the diagram below for where the limit stop should be installed.

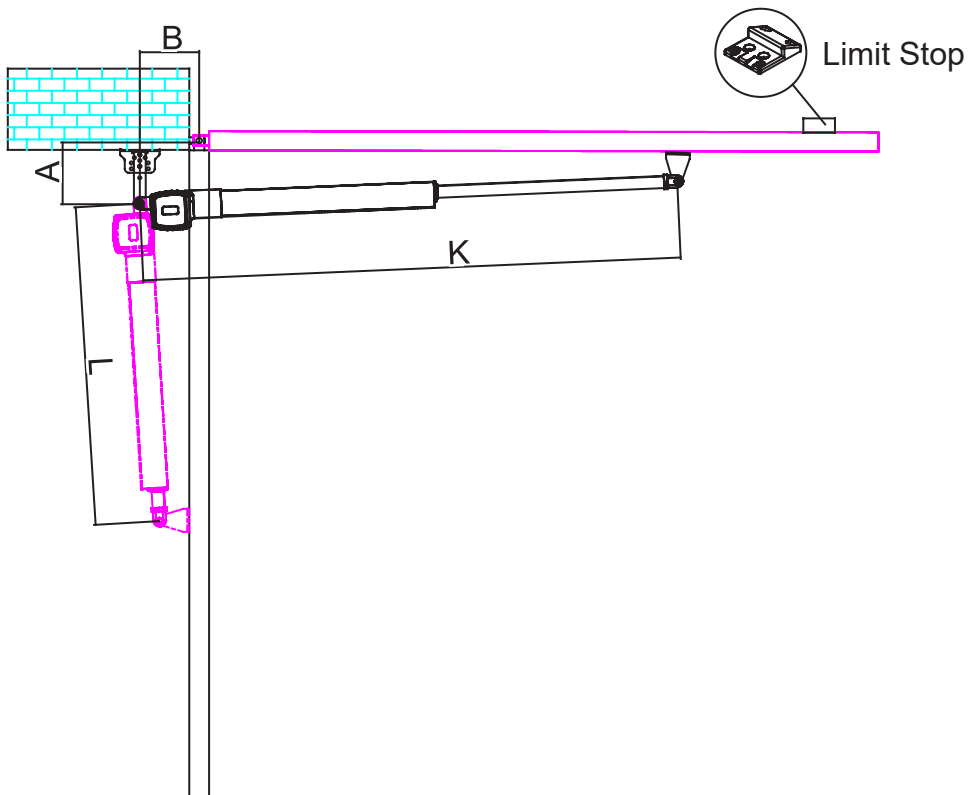

Mounting the Control Box

Pre-Mounting Check

Check that:

- The gate will not enter or obstruct **ANY** public area once its movement is automated.

Warning

If this is impossible for your location, get specific approval from the relevant authority. Post clear warnings and take every protective measure necessary so the gate will not risk accidents or block any public right of way.

- The location for your control box is within sight of the gate but at least 6 feet (2 m) from any moving part. Never mount it on the same post as the gate itself. For best results, mount the box on a sturdy level surface within 6 m (20 feet) of the gate opener in a position inaccessible to anyone reaching through the gate. It must be at least 3 feet (1 m) above the ground to avoid damage from rain and snow and, for best results, place it 5 feet (1.5 m) or higher to help keep it inaccessible to small children and animals.
- The location of the control box is at least 3 feet (1 m) away from any power outlet to avoid possible electrical interference. When using AC power, its own outlet should be visible from the gate and equipped with a GFCI or circuit breaker. If no outlet is available within 300 m (1000 feet) of the control box, the gate should be powered by a 24V DC battery, two 12V DC batteries wired to provide 24V power, and/or a dedicated solar system adequate to its needs (sold separately) or a licensed electrician should be consulted to safely make the necessary adjustments to handle the expected voltage drop along the power cord.
- If using AC power, check that you have main power cord and control bx wire of the correct gauge and length. If you will be using additional wire to extend the length of the provided power cord, be sure to keep all connections clean and well insulated. Any additional wiring should be a 3-core cable at least 1.5 mm² (16 AWG) thick for distances less than 90 m (300 feet) and 2.5 mm² (14 AWG) for distances beyond that. If the power outlet is located a considerable distance from the control box, the wiring should be placed inside a weatherproof PVC sheath and buried to avoid damage from animals, vehicles, etc. and minimize any risk of tripping.
- All lines are fully disconnected from power.

Control Box Installation

1. The control box should be attached to the location previously selected using 4 deck screws or 4 anchor bolts (not included). Be sure the box's strain relief slots are all pointed **DOWN** to help drain excess moisture.
2. Remove the protective cover from the control box. Keep its fasteners nearby. Loosen the strain relief slots at the bottom of the box. In each step below, feed the wires through the strain reliefs before making connections so the wiring can be held securely in place between adjustments.

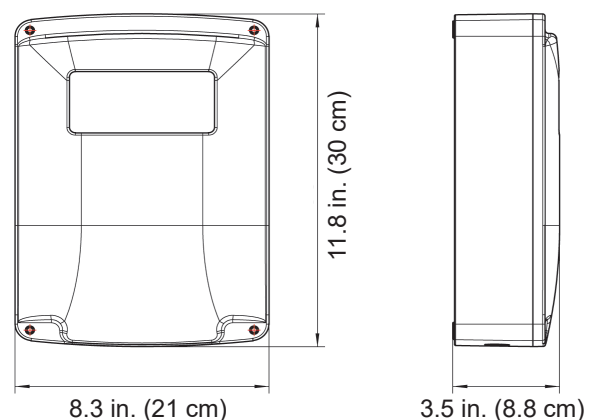

Wiring

Circuit Board Diagram

! Danger

NEVER make electrical connections while your power supply is active. Turn off your AC power or disconnect your battery terminal(s) during any wiring adjustment.

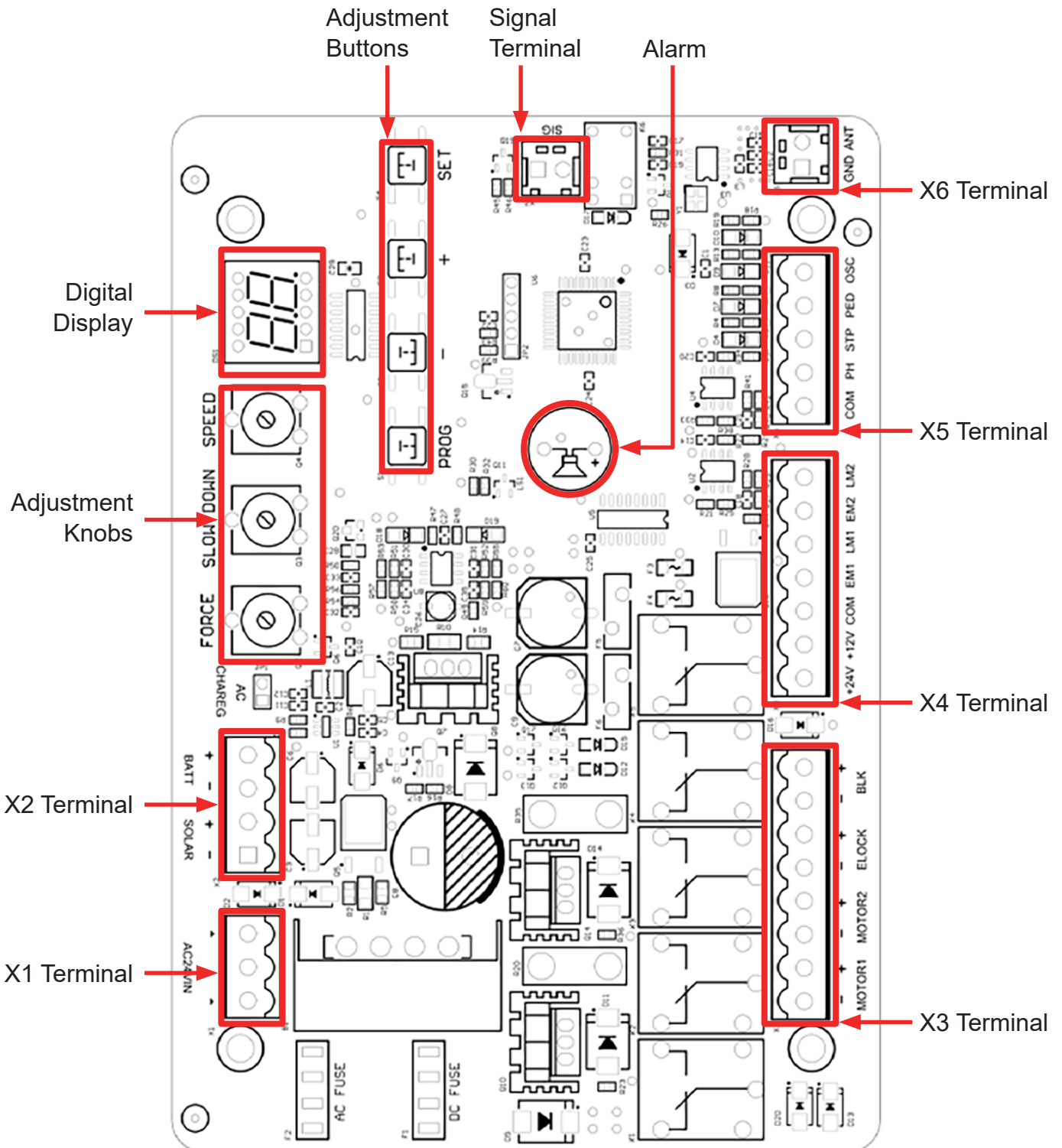

| Terminals | Pins | Descriptions |
|-------------------------|-------------|--------------------------------------|
| X1 Terminal | AC24VIN | 24V AC input |
| X2 Terminal | +SOLAR- | Solar battery input and output |
| | +BATT- | 24V DC input and output |
| Adjustment Knobs | FORCE | Obstruction sensitivity adjustment |
| | SLOW DOWN | Stop distance adjustment |
| | SPEED | Speed adjustment |
| X3 Terminal | MOTOR1 | Motor 1 input and output |
| | MOTOR2 | Motor 2 input and output |
| | -ELOCK+ | Electronic lock input and output |
| | -BLK+ | Alarm lamp input and output |
| X4 Terminals | +24V | 24V DC output |
| | +12V | 12V DC output |
| | EM1 | Disabled |
| | LM1 | Disabled |
| | EM2 | Disabled |
| | LM2 | Disabled |
| X5 Terminal | COM | DC Ground |
| | PH | Photocells input |
| | STP | Keypad stop button signal input |
| | PED | Keypad open button signal input |
| | OSC | Cyclical control signal input |
| X6 Terminal | ANT | Remote control antenna |
| | GND | Antenna ground |
| Signal Terminal | SIG | Wi-Fi module signal input and output |

Power Options

- If you will be using AC power, connect the provided cord or your extension to the main power terminal. This small white box runs to a 10A fuse and 24V transformer which should be prewired to the part of the circuit board's **X1** terminal marked **AC24VIN**. Use a small screwdriver to loosen and tighten the main power terminal's screws as needed. Connect the ground wire to the central pin, the live wire to the left pin, and the return or neutral wire to the right pin. Be sure no wiring is left bare and exposed.

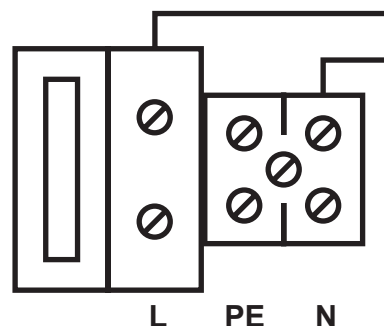

If you will be using a dedicated solar system, follow its separate instructions for installation, adjust its wiring so no power will be flowing as you work, and connect its live wire to the **SOLAR+** pin on the **X2** terminal and its return or neutral wire to the **SOLAR-** pin. Any gate that will be using a solar system should also have a 24V battery attached (see below). This will allow the solar system to charge it during sunny days but still provide consistent service at night, in poor weather, and on occasions where the operator(s) must be used repeatedly in a short time.

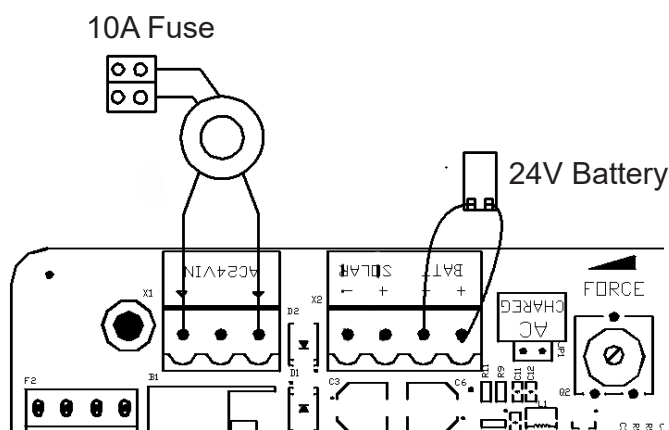

To use a 24V battery to provide primary or backup power, prepare weatherproof housing for it near the control box. Two 12V batteries can also be used as a single 24V unit by wiring the negative terminal of the first battery to the positive terminal of the second. Whether you are using one or two batteries, leave one terminal disconnected to prevent power from flowing during setup and adjustment. Connect the live wire from the battery's positive terminal to the **BATT+** pin on the board's **X2** terminal and the return or neutral wire from the negative terminal to the **BATT-** pin.

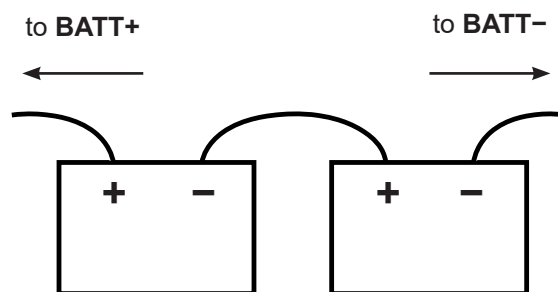

Wiring the Motors

- Each operator should have two wires to connect it to the circuit board for power and control signals. Connect them as shown on the right. The **MOTOR** pins are located on the board's **X3** terminal.

| Wire Color | Master Operator | Secondary Operator |
|------------|-----------------|--------------------|
| Red | MOTOR1- | MOTOR2+ |
| Black | MOTOR1+ | MOTOR2- |

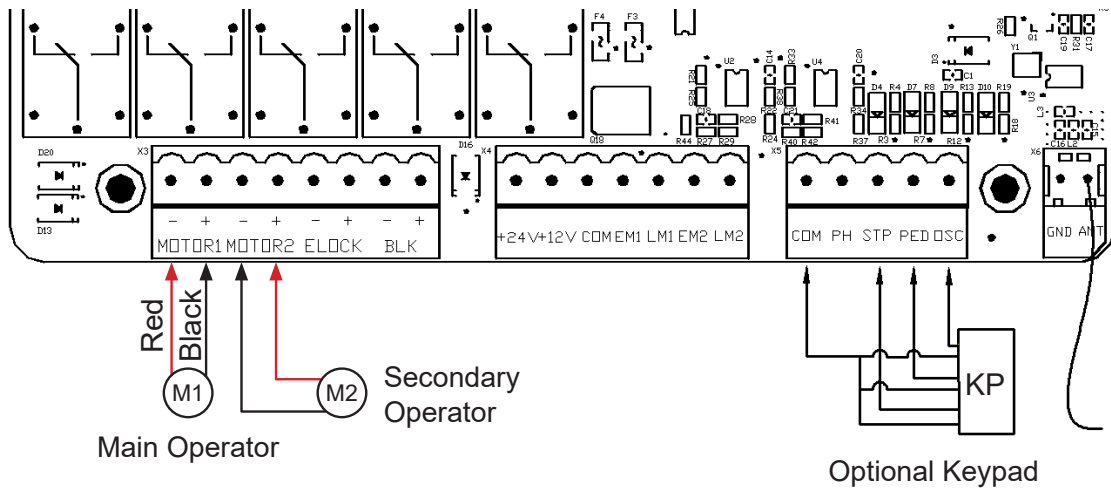

- Double check that the wire from the remote control antenna is securely connected to the **ANT** pin on the **X6** terminal.

Wiring a Keypad

- If your gate will have a separate keypad entry system, follow its separate instructions for installation and connect its wiring to the **X5** terminal. The return or neutral wires should be connected to the **COM** pin, the signal wire for **STOP** commands to the **STP** pin, the signal wires for pedestrian commands to the **PED** pin, and the signal wire for cyclical control—OPEN/STOP/CLOSE/STOP—to the **OSC** pin.

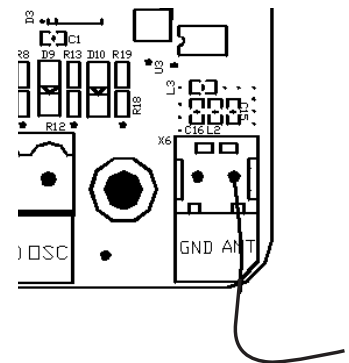

Wiring Other Accessories (Optional)

- Connect any other accessories you might wish to use with this gate opener, following their separate manuals to ensure safe and reliable operation. Some of the more common accessories for this gate opening system include:

Electronic Locks

To automatically control an electronic lock on your gate, connect its signal wire to the **ELOCK+** pin on the board's **X3** terminal. Connect its return or neutral wire to the **ELOCK-** pin.

Alarm Lights

To automatically activate an alarm or indicator light when the gate is in motion, connect the light's signal wire to the **BLK+** pin on the **X3** terminal. Connect the light's return or neutral wire to the **BLK-** pin.

Infrared Sensors ("Photo Eyes")

As shown below, connect the sensors' common (COM) and return or neutral pins (V-) to the **COM** pin on the board's **X5** terminal. Connect the receiver's normally closed (NC) pin to the **PH** pin on the same terminal. Connect the power input pins (V+) on each sensor to the 24V power supply pin (**+24V**) on the board's **X4** terminal. Remove any other wire connecting any of these pins directly, but save any such wire in a safe place in case you ever need to use the operator(s) without the photocells.

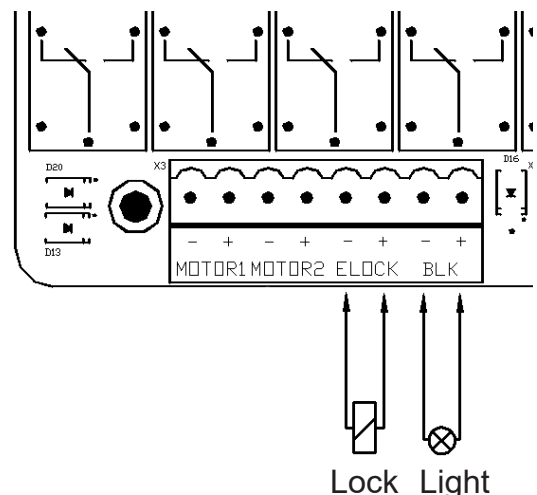

Initial Testing

Setting Dual Actuators

- Your system should come correctly preprogrammed to work as a single operator for a single gate or as paired operators for two separate gate leaves.
 - To confirm this before testing the gate, press the **PROG** button until the digital display changes from "--" to "NE".
 - Press **+** or **-** until the display reads "SP".
 - Press **SET** to confirm that the circuit board is using the proper operational mode. The display should read "OF" for one operator working alone and "ON" for two operators working together.
 - If the setting doesn't match your system, use **+** or **-** to toggle to the correct setting and press **SET** to confirm your change.

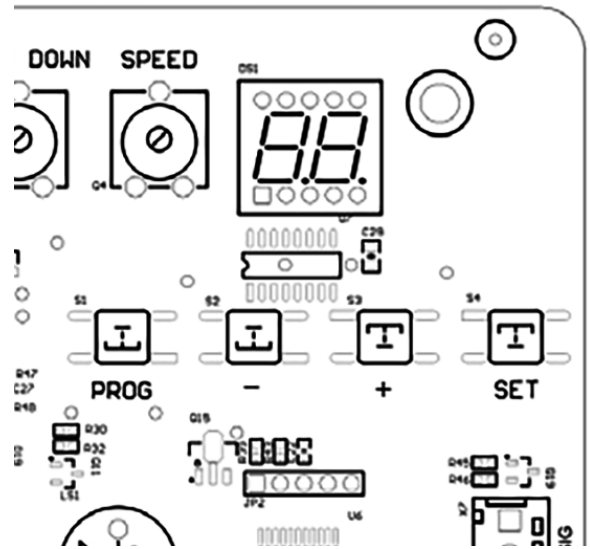

Setting PSO

Warning

Install the limit stop outside your gate if you choose to use PSO.

- Your system should come preprogrammed to use pull-to-open operation, opening inward towards your property. If your gate will be using push-to-open operation instead, pushing the gate outward, you will need to reset that parameter.
 - Press the **PROG** button until the digital display changes from "--" to "RL". Press **+** or **-** until the display reads "dR".
 - Press **SET** to enter the submenu and use **+** or **-** to toggle the setting from "IN" to "OU".
 - Press **SET** to confirm your change.

Travel Setting

Warning

- *By default, the actuator works under such a mode: it runs at full speed for 15 seconds after receiving a signal to open the door and only slows down when coming into contact with a limit stop or a wall. This default mode is customizable, but it is restored **EVERY TIME** the **SPEED** adjustment knob is turned.*
- **ALWAYS** retrain the circuit board about the limit stop once the **SPEED** adjustment knob is turned.
- *Clear any obstacles from the gate's path and keep all bystanders away throughout the following steps.*

Upon using the actuator(s) to open or close your gate for the first time, **DO** set its travel distance following the steps below so that your gate can stop at the right position and at your desired speed.

1. Open your gate to its half-open position and lock the operator
2. Hold the **+** button on the control board until the display reads "SU".
3. Your gate should start to close, stop at the limit stop, open to its fully opening position, and close and stop for a second time, indicating the retraining is done. If your gate did not start to close but to open, access the circuit board and switch the negative wiring with the positive wiring of the motor.

Warning

ATTENTION! *For either PLO or PSO setup, after being initially opened, your gate should be moving to its closed position. If it is moving in the other direction, stop it and switch the operator's motor pins' wiring on the circuit board.*

Setting the Speed & Obstruction Sensitivity

- If the gate starts up too slow or too fast, use the **SLOW DOWN** knob on the circuit board to adjust the speed.

If the door stops abruptly due to wind or the friction of the gate itself or if the gate does not react appropriately to the end stops or closes you are using, turn **FORCE** knob to adjust the operator's force against resistance.

If you, by accident, turned the **SPEED** knob during any point of these steps, you have to start all over again.

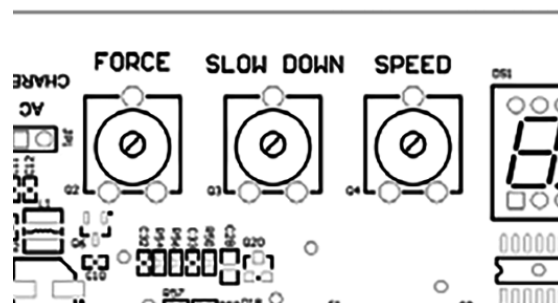

Warning

ALWAYS retrain the circuit board about the limit stop once the **SPEED** adjustment knob is turned.

Testing the Single Control Mode

- The top button on both remote controls should already be paired with your circuit board. They use a single control mode at a distance of up to 98 feet (30 m). Pressing either button should cycle through the commands OPEN→STOP→CLOSE→STOP. Test both remotes through the full cycle of commands. The gate should now automatically stop at the right places but be ready to manually stop the gate using the remote if the memorized settings do not activate correctly. Confirm that the display shows “OP” as the door is opening and “CL” as it is closing. (If the top button on either remote does not control the gate, see below for pairing instructions and then repeat this testing.)

Testing the Closing

- Your system does not come preprogrammed to automatically close your gate after reaching its fully open position. If you activate this function (see below), test that it works correctly by using either remote to open the gate to its fully open position and waiting to see if it begins closing automatically. Confirm that the remote can still stop the gate when it is closing automatically.
- If you have installed any additional safety features like an infrared sensor system or magnetic detection loops, test them now and confirm that they work correctly and safely.
- Disconnect your system from its power source. If any abnormalities have been detected during testing, make the necessary adjustments—e.g. by repositioning your end stops, shifting the adjustment knobs, or changing the stored parameters (see below)—or contact Customer Service. Once everything is functioning, replace the circuit board and motor covers and their fasteners, reconnect power, and enjoy!

4. Remote Pairing

The top button of each included remote should come already paired with your gate opener. Up to 30 additional remotes or wireless control buttons can be paired to the gate's circuit board. Be sure that they use the 433.92 MHz (LPD433 Channel 35) radio band or can be configured to do so.

Warning

NEVER pair the same button to 2 different gates or devices at the same time.

1. Remote pairing must be done with the circuit board exposed and connected to power. Be careful and only touch the adjustment buttons while the circuit is live. Disconnect your power supply while the control box's cover is being removed or replaced and while making any adjustment to any wiring.
2. Press the – button until the digital display shows the current remote control mode (“PO”, “Pd”, or “SE”) and then displays the number of currently paired remotes. Release the – button.
3. Press the remote button to be paired or enter a passcode and press the open button on your wireless control.
4. Press the same button on the remote control again or reenter the passcode and press the open button again on the wireless control. The digital display should show the new total number of devices and then automatically return to standby mode, displaying “--”.
5. The button or keypad is now paired and can be used to open or close the gate. This pairing should remain stored in memory even when power to the gate opener is cut accidentally or at its circuit breaker.
6. Test that your gate responds correctly to commands from the new remote or keypad. When you are finished pairing and testing, disconnect the gate from power, replace the control box's cover and fasteners, and restore power.

When remote inputs are handled in four-button mode (see the “Pd” setting below), you can also pair a remote without opening the control box. Hold the bottom two buttons on any previously installed remote control to authorize remote pairing. Hold the bottom two buttons on the new remote to pair it. Test that each of the four buttons works safely and correctly.

This board cannot unpair an individual remote. If you need to remove lost remotes from the system's memory, you will need to delete **ALL** stored remotes at once. Open the control box as before. Hold the + button for about eight seconds. (Alternatively, press the **PROG** button until the digital display changes from “--” to “NE”. Press + or – until the display reads “RE”. Press **SET** to access the remote submenu. Press + or – until the display reads “rE”. Press **SET** to confirm the deletion and exit.) Use any remote to test that all stored remotes have been purged.

Once this process is successful, pair the remotes that you want to continue using in the same way as before.

5. Parameter Adjustment

Aside from the three settings controlled by the adjustment knobs, all other parameters are controlled using the adjustment buttons and the digital display. There are two separate menus, one for basic settings and another for advanced settings.

In each case, use **PROG** to enter the main menus; **+** and **-** to toggle through menus and adjust values up or down; and **SET** to select submenus or confirm and save your changes. You can also wait one minute for the system to reset to standby (“--”) without saving changes.

Basic Setting Menu

| Submenu Name | | Options | |
|--------------|--------------------|-----------|---|
| NE | Operational Mode | SA | Use this setting for standard operation without autoclosure |
| | | PE | Activates automatic gate closure |
| | | HO | Activates automatic gate closure and only responds to one remote at a time (for commercial and large residential units) |
| | | oc | Use this setting for standard fixed 3 button control systems |
| | | oA | Use this setting for 3 button systems with automatic closure |
| SP | Gate Mode | ON | Use this setting for 2-leaf gates with twin operators |
| | | OF | Use this setting for single gates with a single operator |
| OH | Gate Open Delay | ## | Automatically delays opening the gate after a signal is received for this number of seconds (3 sec. default) |
| CH | Gate Close Delay | ## | Automatically closes the gate from a fully open position after this number of seconds (15 sec. default) if activated |
| RE | Remote Settings | PO | Uses standard cyclical operation from a single button |
| | | Pd | Uses four separate buttons for opening, closing, stopping, and opening the master side only on a 2-leaf gate |
| | | SE | Opens only the master side of a 2-leaf gate |
| | | rE | Deletes a saved remote (see above) |
| LC | Energy Saving Mode | ON | Reduces power consumption after more than 1 minute without use but causes a slightly slower response time |
| | | OF | Uses standard operation |

Warning

Electronic locks cannot be used when the OH value is set to 0, 1, or 2 seconds.

Advanced Setting Menu

| Submenu Name | | Options | |
|--------------|-----------------------|-----------|---|
| rL | Resistance Limit Time | r1 | Sets the time in seconds that the master operator will slow at each end of its movement |
| | | r2 | Sets the time in seconds that the secondary operator will slow at each end of its movement |
| | | L1 | Adds a value in 1/100ths of a second to the r1 value for fine tuning the master operator's movement |
| | | L2 | Adds a value in 1/100ths of a second to the r2 value for fine tuning the secondary operator's movement |
| PH | Infrared Mode | NO | If an infrared sensor is attached to the system, use this setting for those that use a normally open signal |
| | | NC | Use this setting with any infrared sensors that use a normally closed signal |
| EL | Electric Lock Mode | NO | If an electronic lock is attached to the system, use this setting for those that use a normally open signal |
| | | NC | Use this setting with any electric locks that use a normally closed signal |
| Oc | Lock Pushback | NO | Opens the gate directly |
| | | YS | Pushes outward when first opening, used to prevent catching on some delayed electric locks |
| PA | Alarm Light Mode | NO | If an alarm light is attached to the system, it will stay on continuously when the gate is in motion |
| | | FL | Any alarm light will flash on and off when the gate is in motion |
| LP | Limit Mode | RS | Processes the open and close limits based on stored values and resistance detection |
| | | LS | Do not use this setting for these operators, as it requires additional wiring and components |
| Nd | Gate Type | 00 | Use this setting for extremely heavy gates that respond poorly even with the POWER adjustment knob is at its maximum |
| | | 01 | Use this setting for standard gates |
| | | 02 | Use this setting for better operation with extremely small or light gates (under 110 lb. or 50 kg) |
| dr | Gate Direction | IN | Use this setting for pull-to-open gates |
| | | OU | Use this setting for push-to-open gates |
| bE | Alarm Buzzer | YS | Sounds an alarm when the gate moves or an error occurs |
| | | NO | Disables the alarm (Note that such an audible alarm may be required for automatic gates in your area) |
| FP | Parameter Reset | OF | Exits without changes |
| | | ON | Removes all stored information, requiring setup to be repeated |

6. Maintenance

- Always supervise children and pets near the gate, the operators, and their controls to prevent accidents.
- Always fully disconnect the control box from its power supply before removing its cover or making any adjustments to its wiring, except as specifically directed elsewhere in this manual. Use trained and licensed electricians for rewiring or electrical repair work.
- Keep your gate and its hinges clean and free of any corrosion, grime, or obstructions.
- Lubricate hinges as needed and, in climates where temperatures reach 34°F (1°C) or lower, spray silicone on the operator piston(s) every 4–6 weeks to prevent freezing.
- If your gate is not in regular use, test your gate opener’s operation at least once a month. If any problems are noticed during testing or normal use, disconnect the control box from power, unlock the operator(s), and test manually that the gate still moves smoothly on its own. Tighten, repair, or replace problematic parts as needed. Only use identical components and always fully replace damaged or malfunctioning electrical cables.

7. Troubleshooting

| Possible Problems | Typical Solution(s) |
|--|--|
| The gate does not open or close normally and the digital display does not activate on the circuit board. | Verify that the power supply is functioning properly. |
| | Check that the fuse is not blown. If necessary, replace it with an identical 10A 250V fuse. |
| | Have a certified electrician rewire your system. |
| Operator 1 or 2 is blocked from opening (errors “E1” or “E2”) or closing (“E3” or “E4”). | Remove any obstacles that might be in the gate’s path. |
| | Decrease the gate’s obstruction sensitivity with the FORCE knob. |
| | Increase the gate’s deceleration distance with the SLOW DOWN knob. |
| No infrared signal is detected by the circuit board (“E5”). | Remove anything that might be in the sensors’ path. |
| | Check all wiring for any damage or poor connections. |
| | If there is no IR system, replace the short wire between the PH and COM pins on the X5 terminal. |
| The master operator closes long before the secondary operator (“E6”). | Adjust the open delay (“OH”) settings to see if the situation resolves. |
| | Check all wiring for any damage or poor connections. |
| | Repeat the steps in Initial Testing above, teaching the system about its route again. |
| The motor overheats or the system misunderstands the operator(s) as overheated (“E7”). | Wait for the operator(s) to cool before resuming operation. |
| | Repeat the steps in Initial Testing above, teaching the system about its route again. |
| | Have a certified electrician check the Hall sensors and repair or replace as needed. |

| Possible Problems | Typical Solution(s) |
|---|--|
| The system does not have or has forgotten its route information (“E8”). | Repeat the steps in Initial Testing above, teaching the system about its route again. (Remember that this is necessary after any adjustment of the SPEED knob.) |
| The gate opens but does not close. | If an IR system is installed, correct any problems it might have. If there is no IR system, replace the wire shorting the IR pins. |
| | Decrease the gate’s obstruction sensitivity with the FORCE knob. |
| The gate does not respond to commands from a remote. | Repeat the remote pairing process. |
| | Remove any obstructions between the remote and the control box. |
| | Replace the remote’s battery. |
| | Check that the receiver antenna is wired to the ANT pin. |
| The gate does not move even though the control box and operator(s) function normally. | Lubricate or repair the gate’s hinges. (Again, ball bearing hinges are highly recommended for any large gates.) |
| | Check that all components and fixtures remain level, fixing as needed. |
| The gate suddenly stops or reverses when moving. | Remove any obstacles that might be in the gate’s path. |
| | Check any IR sensors and wiring, adjusting as necessary. |
| | Decrease the gate’s obstruction sensitivity with the FORCE knob. |

8. Disposal

Electrical products should not be disposed of with household products. In the EU and UK, according to the European Directive 2012/19/EU for the disposal of electrical and electronic equipment and its implementation in national laws, used electrical products must be collected separately and disposed of at the collection points provided for this purpose. Locations in Australia, Canada, and the United States may have similar regulations. Contact your local authorities or dealer for disposal and recycling advice.

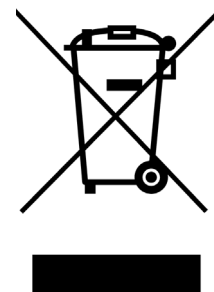

Contact Us

Thank you for choosing our products! If you have any questions or comments, contact us at contact@cssupportgroup.com and we'll resolve your issue ASAP!

For a .pdf copy of the latest version of these instructions, use the appropriate app on your smartphone to scan the QR code to the right.

