

**WALKER EDISON**  
TM

## Glass Bookcase

SKU# WESAM41OS3

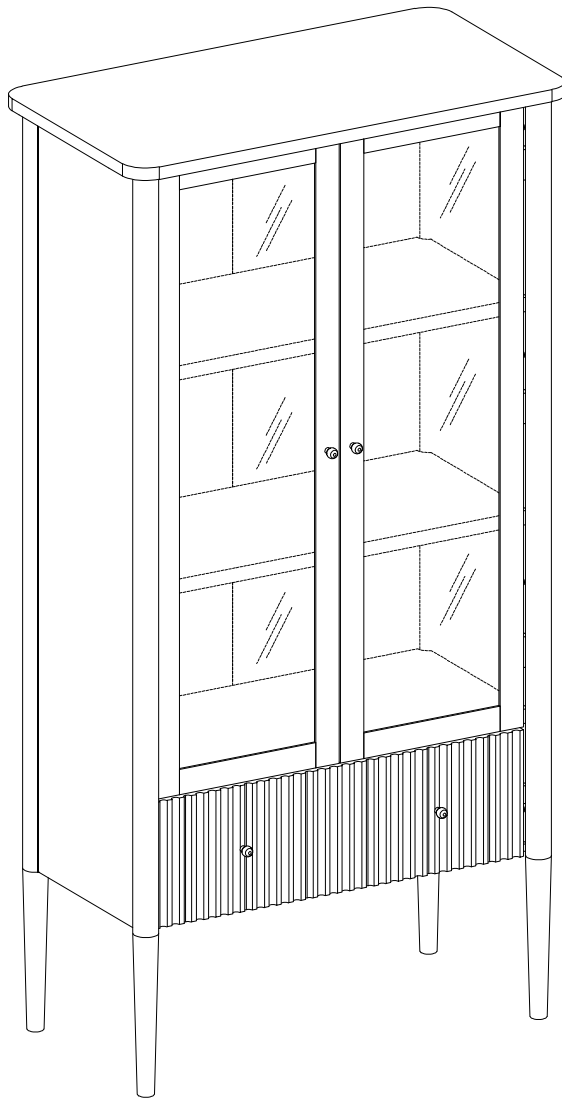

**For Residential Use Only**

Please visit our website for the most current instructions, assembly tips, report damage, or request parts. [www.walkeredison.com](http://www.walkeredison.com)



# Time to get started

Set up a clean and soft workplace to get started and avoid damage during the assembly. It also helps to double-check you've got all the pieces and parts before diving in to assembly.

Estimated time for assembly

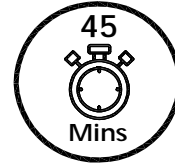

People recommended for assembly

Make it a team effort! Grab a friend for quicker, easier assembly.

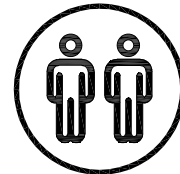

2 People Build

Tools Needed

Grab a Phillips head screwdriver to conquer this assembly

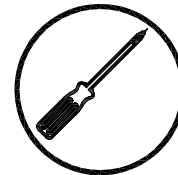

Use power tools with caution

You can cause cracking or damage to the material and easily strip the hardware. If you choose to use a power tool, your product will no longer be covered under Walker Edison' warranty.

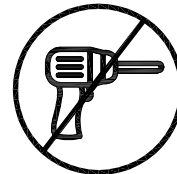

Glue is provided to secure wood dowels in place

When inserting dowels, locate the appropriate hole, place a small amount of glue in the hole, and then insert the dowel. Wipe away excess glue immediately.



Scan to get assembly tips and help!







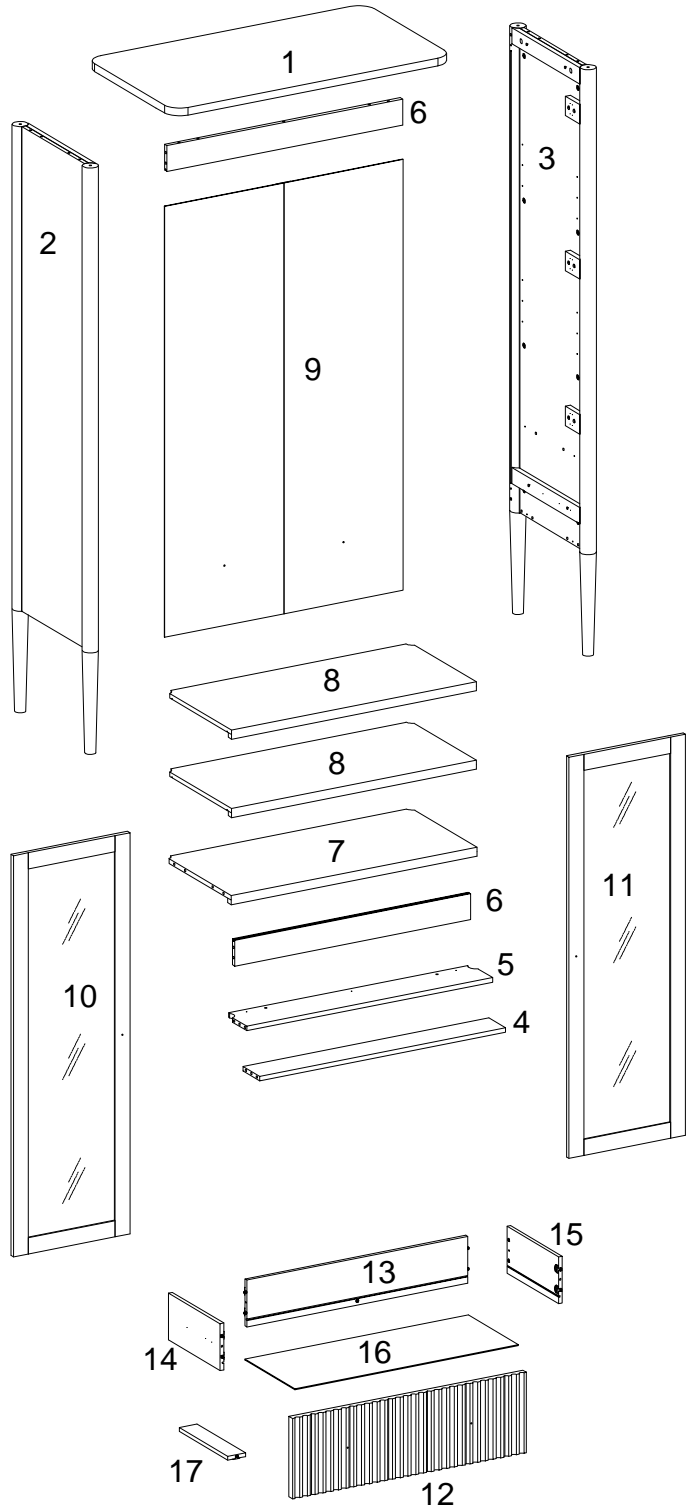





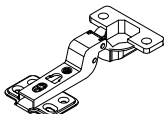

# Parts List

Part Number	Description	Quantity
1	Top Panel	1
2	Left Panel	1
3	Right Panel	1
4	Front Support Panel	1
5	Back Support Panel	1
6	Trim Panels	2
7	Fixed Divider	1
8	Adjustable Shelf	2
9	Back Panel	1
10	Left Door	1
11	Right Door	1
12	Drawer Front Panel	1
13	Drawer Back Panel	1
14	Drawer Left Panel	1
15	Drawer Right Panel	1
16	Bottom Drawer Panel	1
17	Drawer Support Panel	1

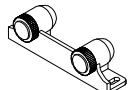











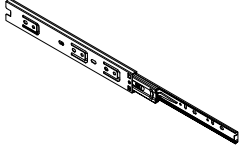

# Hardware List

Part	Size	Name	Quantity
A	 8x30mm	Wooden dowel	28
B	 6x30mm	Wooden dowel	4
C	 6x35mm	Cam bolt	22
D	 15x11mm	Cam lock	22
E	 30mm	Sticker	38
F	 35mm	Hinge	6
G	 3.5x15mm	Screw	36
H		Door Stopper	1
J	 3x15mm	Screw	2
K		Bolt	2
L	 8x5x16mm	Shelf support pin	8
M		Plastic wedge	16
N	 3x17mm	Screw	16

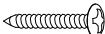

# Hardware List

Part	Size	Name	Quantity
P		Handle	4
Q	 5/32"x21mm	Bolt	4
R	 10"	Drawer Glide*	1 Set
<small>* Note: This piece comes preassembled for shipping purposes and must be disassembled to complete the desk assembly.</small>			
S	 3x12mm	Screw	12
T	 3x15mm	Screw	2
U	 12x3mm	Rubber Pad	2
V	 4x12mm	Screw	2
W	 4x25mm	Screw	2
X		Plastic strap	2
Y		Wall Anchor	2
Z		Glue tube	2

*The hardware quantities listed above are required for proper assembly.  
Extra hardware pieces may be included.*

# Step 1

Let's get started! Using a Phillips head screwdriver, screw the cam bolts (C) into the Right Panel (3). Then, insert wooden dowels (A).

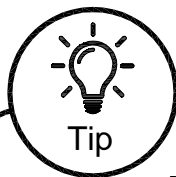
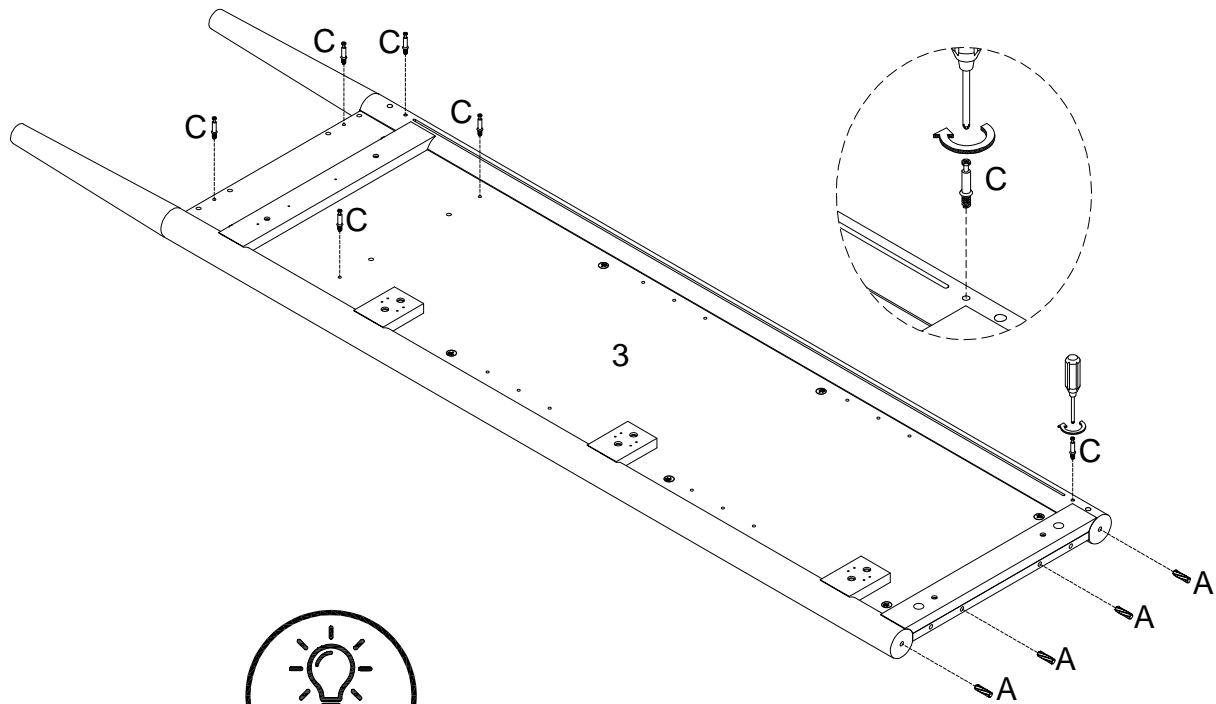

Tip

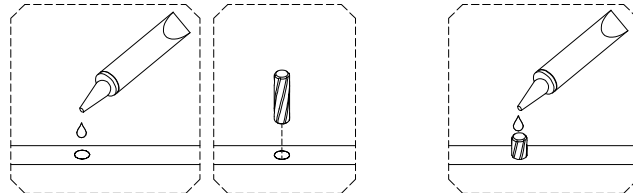

1: The provided glue is to secure wood dowels in place. When first inserting dowels, locate the appropriate hole for the dowel, place a small amount of glue in the hole and insert the dowel. Wipe away excess glue immediately.

2: In future assembly steps when dowels are necessary to attach assembly parts together, place a small amount of glue on the end of the dowel before attaching parts together. Wipe away excess glue immediately.

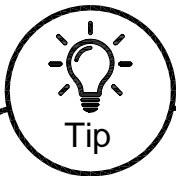

Tip

To keep your product looking its best and scratch-free, try assembling it on a soft surface like carpet or a blanket. This helps prevent any accidental scratches and keeps your furniture in top shape!

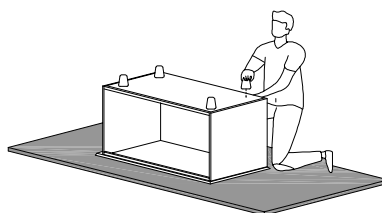

# Step 2

Repeat the previous step for the Left Panel (2). Screw the cam bolts (C) into the Left Panel (2). Then, insert wooden dowels (A).

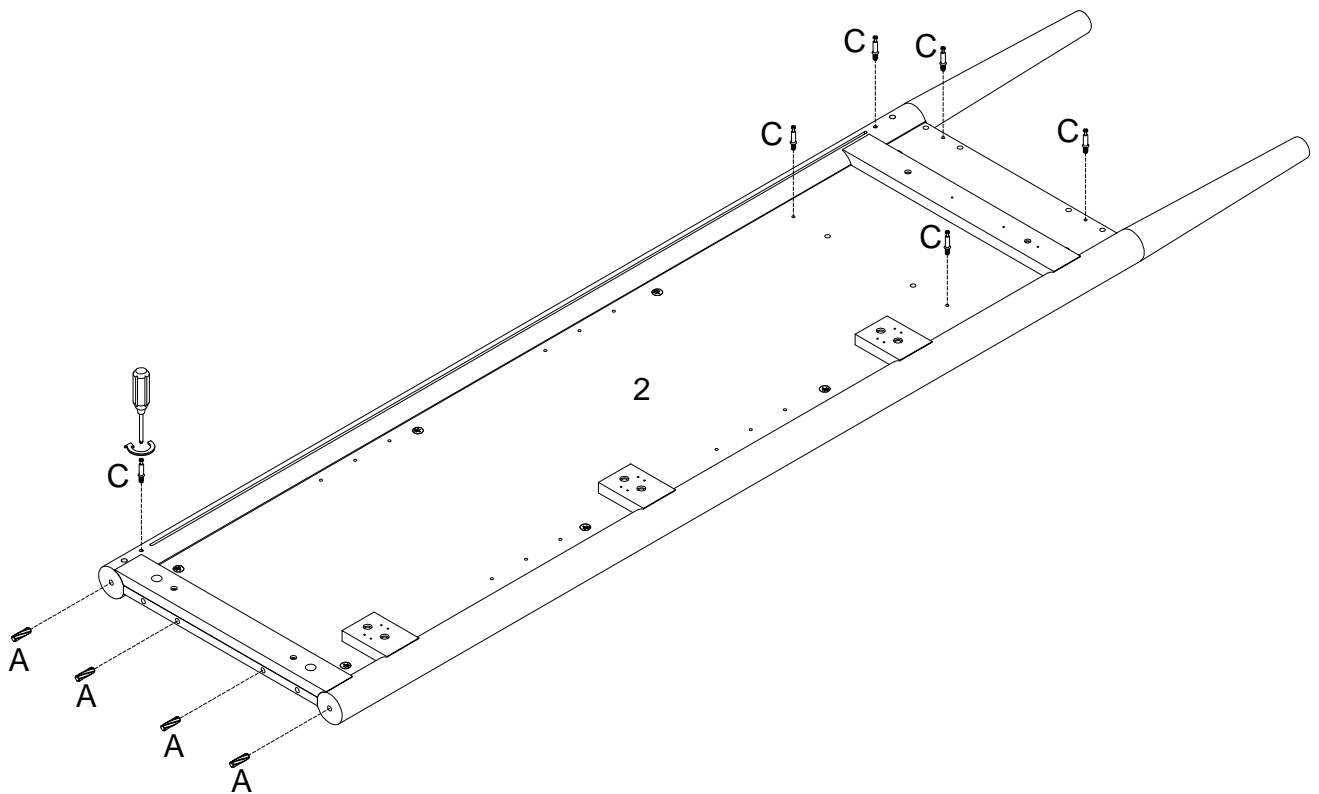

# Step 3

Press the plastic lever to remove the drawer member from the cabinet member on each drawer glide (R).

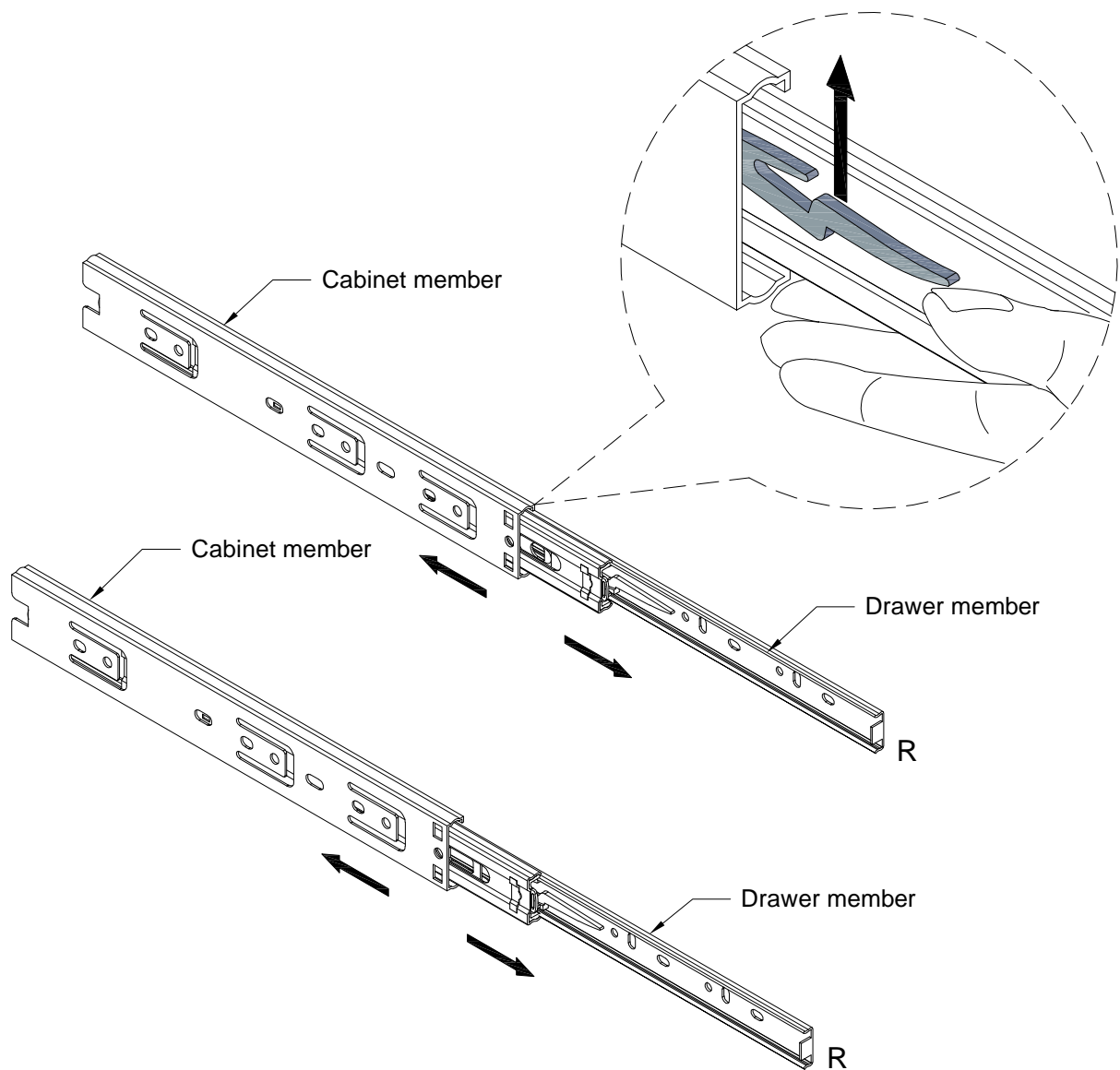

# Step 4

Attach the cabinet member sides of the drawer glides (R) to the Left Panel (2) and the Right Panel (3) using the (S) screws.

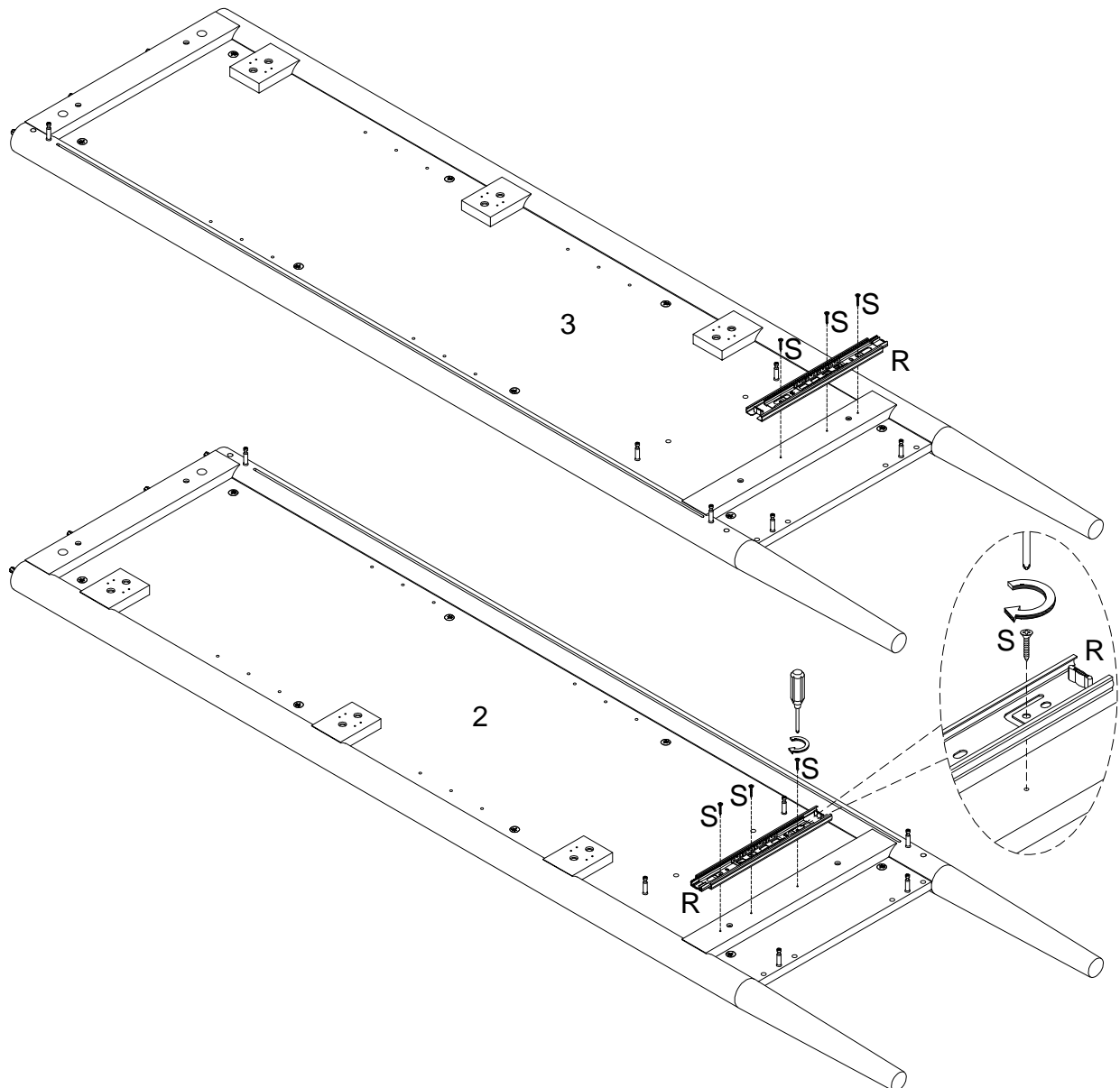

# Step 5

Insert wooden dowels (A) into both ends of the Fixed Divider (7).

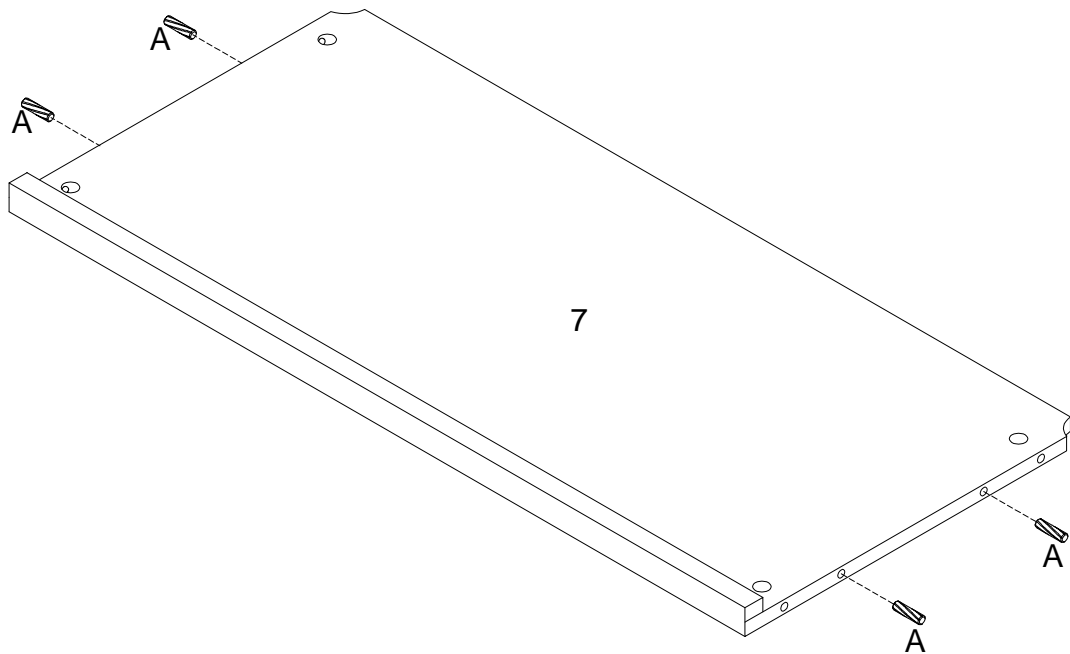

# Step 6

Secure the Fixed Divider (7) to the Right Panel (3) using the cam bolts (C). Insert cam locks (D) and tighten with a screwdriver.

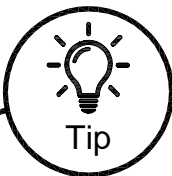
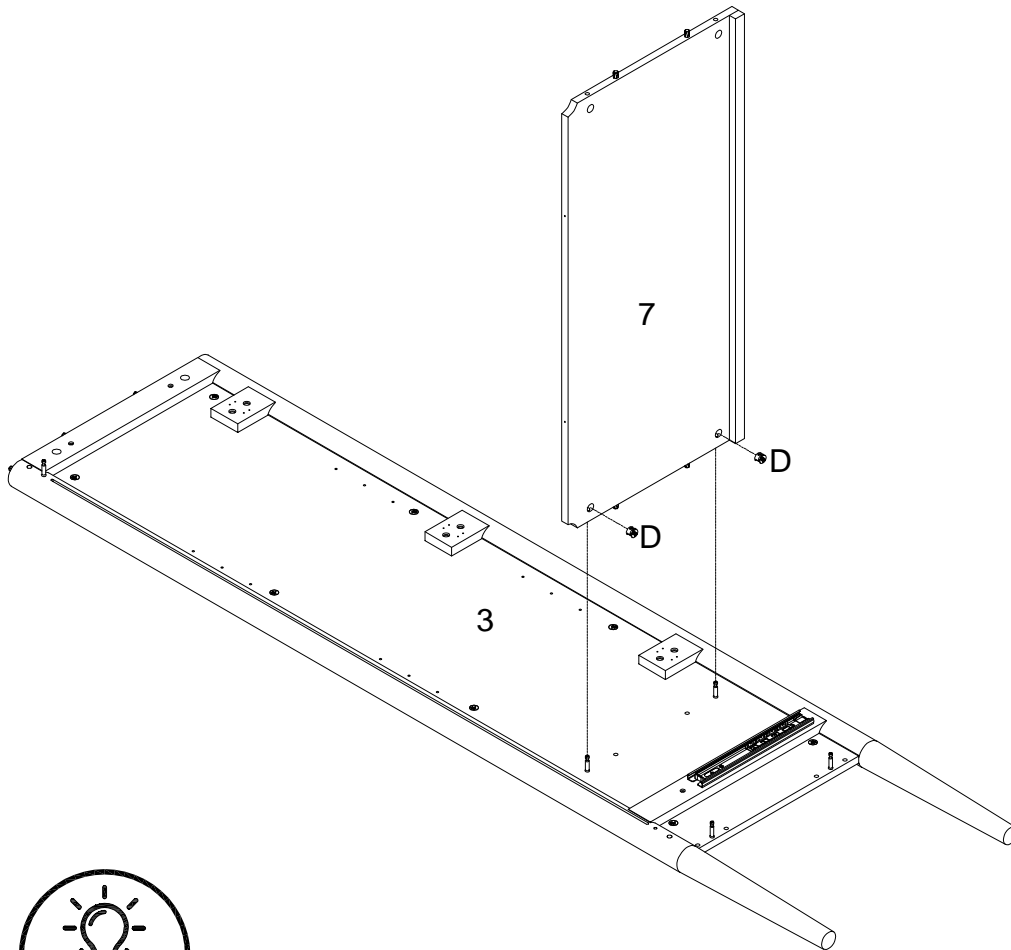

Tip

## Cam Locks

Cam Locks help securely join two pieces together. Follow these easy steps.

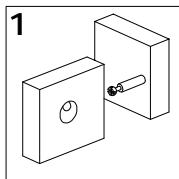

1: Insert Cam Bolt into bolt holes on the flat side. Don't over tighten!

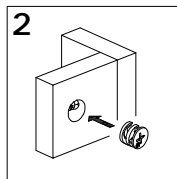

2: Fit the proper holes on the edge of the other part over the Cam Bolts. You should be able to see the cam bolts through the larger hole on the side.

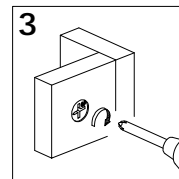

3: On the back of the Cam Lock will be a "C" shape. Insert the Cam Lock so the opening of the "C" fits over the Cam Bolt. Tighten with the screwdriver.

# Step 7

Using a Phillips head screwdriver, screw cam bolts (C) into the Back Support Panel (5). Then, insert wooden dowels (A) into the Front Support Panels (4), Back Support Panel (5), Trim Panels (6).

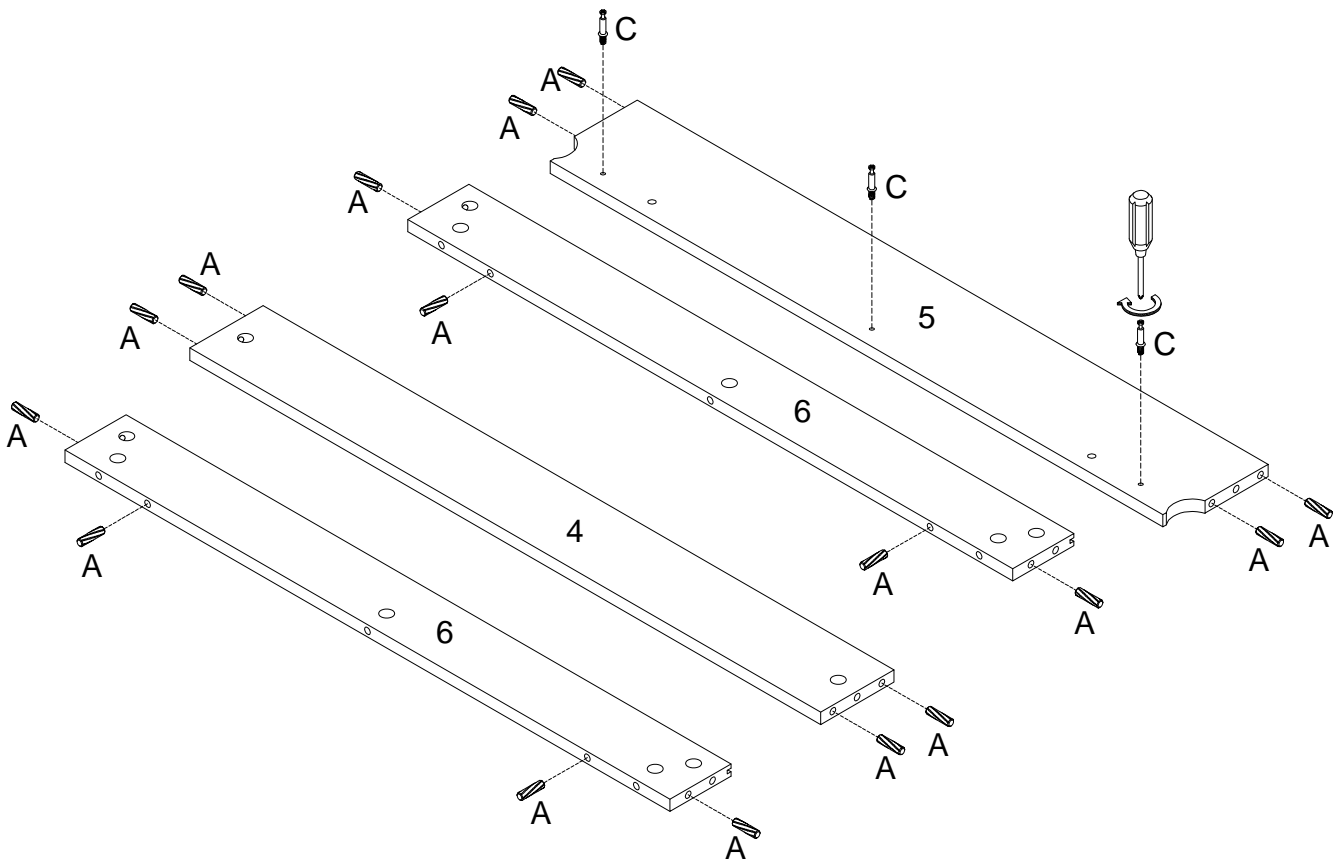

# Step 8

Connect a Trim Panel (6) to the Back Support Panel (5). Insert cam locks (D) and tighten with a screwdriver.

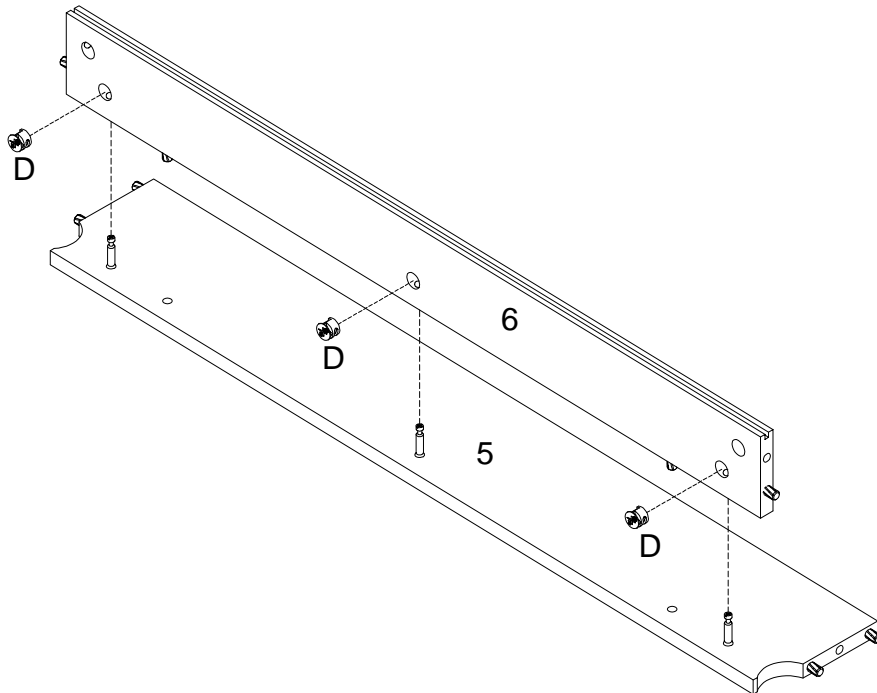

# Step 9

Attach the Trim Panel (6) to the Right Panel (3) . Next, connect both the Front Support Panel (4) and the combination of the Trim Panel (6) and Back Support Panel (5) to the Right Panel (3). Insert cam locks (D) and tighten them using a screwdriver.

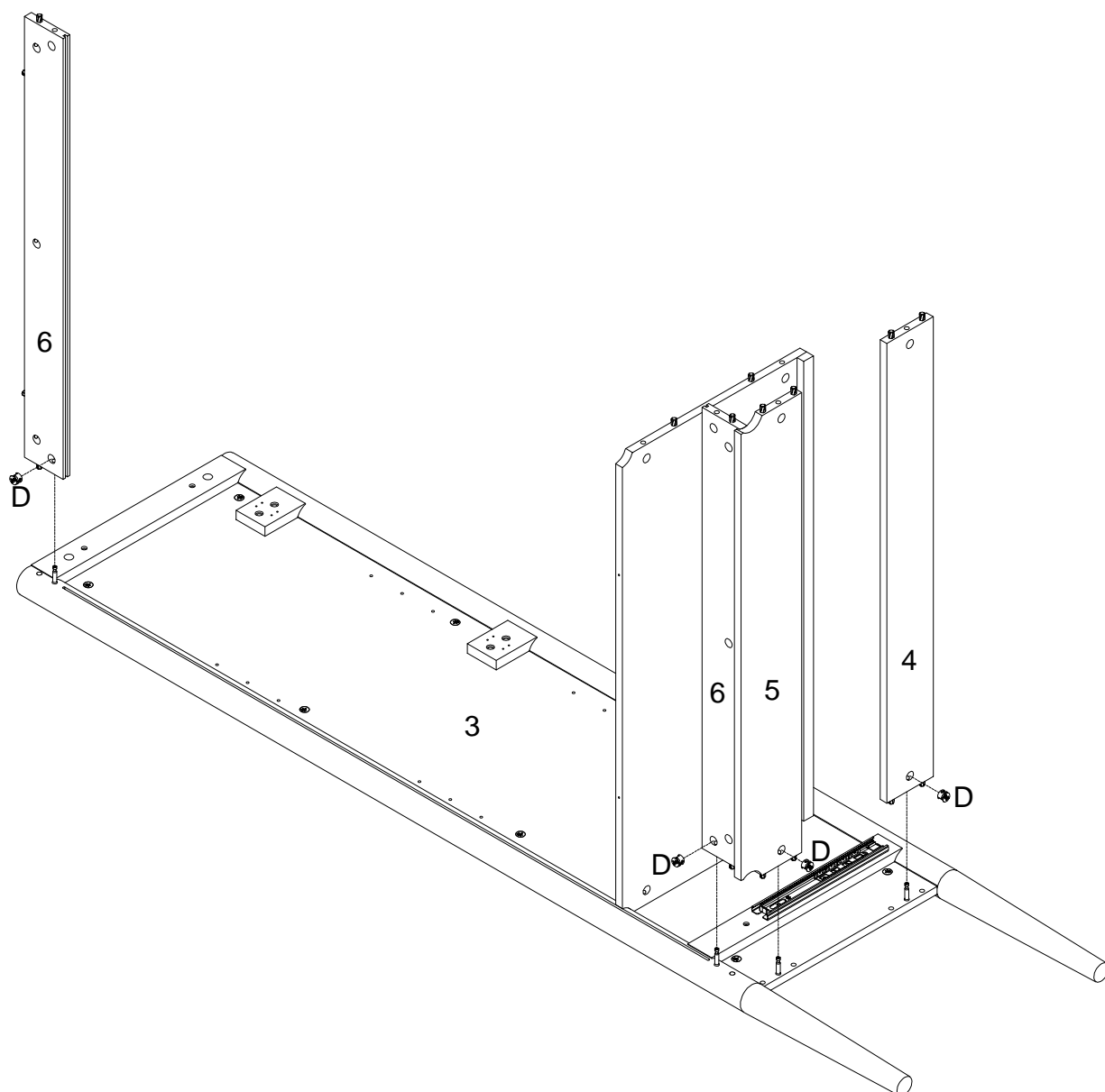

# Step 10

Unfold the back panel (9) and slide it in place using the grooves as your guide.

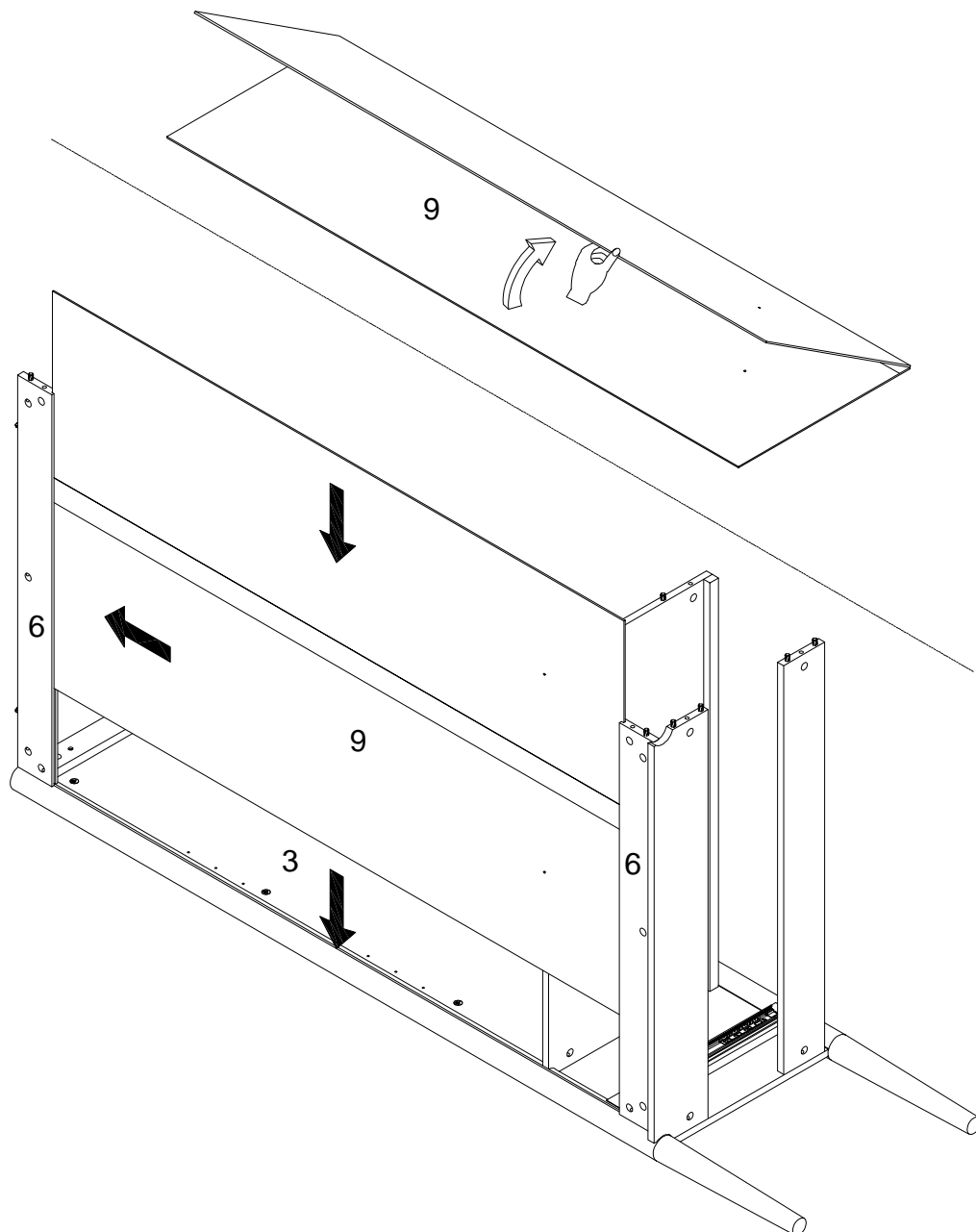

# Step 11

Attach the Left Panel (2) to the rest of the unit using the cam bolts (C). Insert cam locks (D) and tighten with a screwdriver.

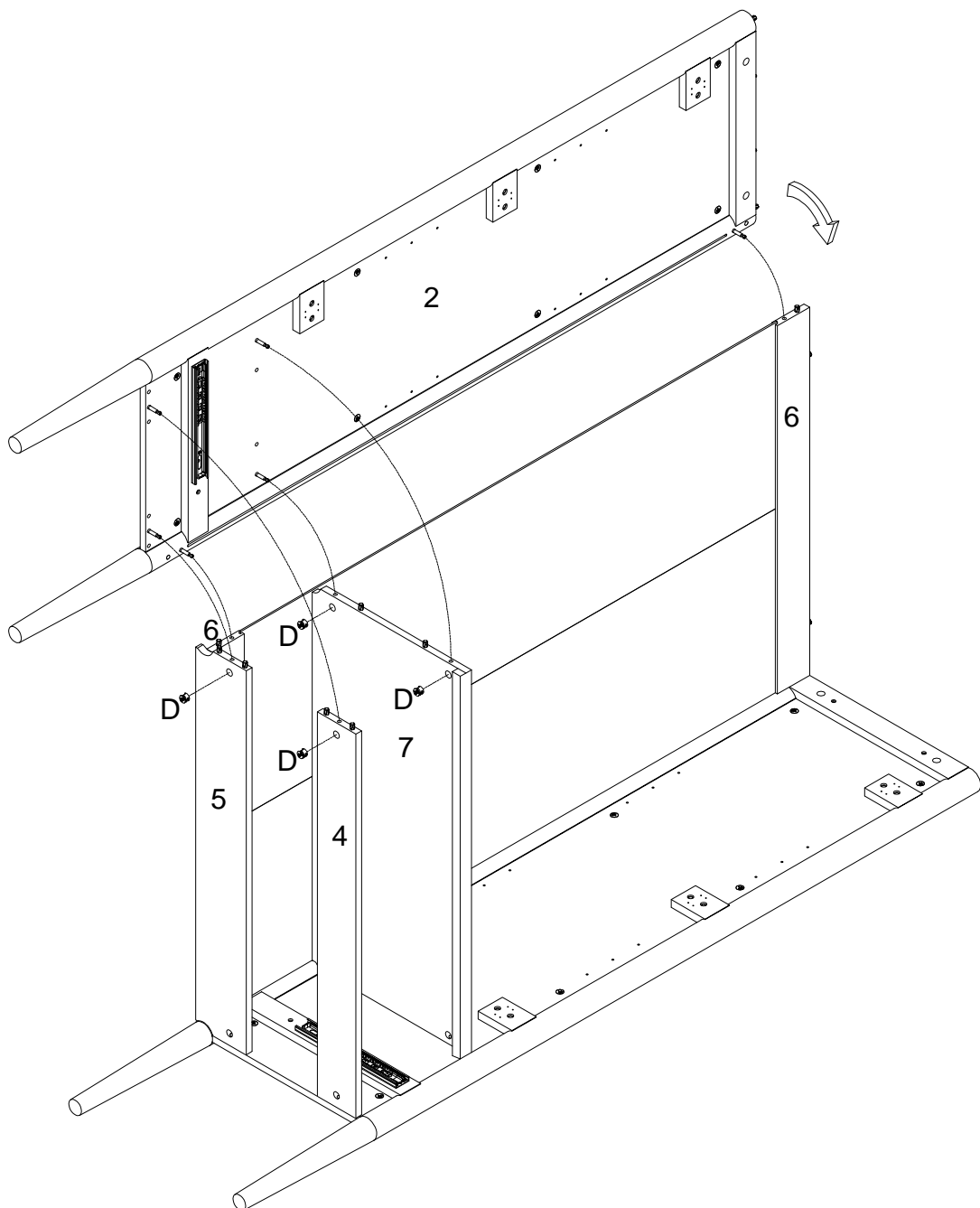

# Step 12

Insert cam locks (D) and tighten with a screwdriver.

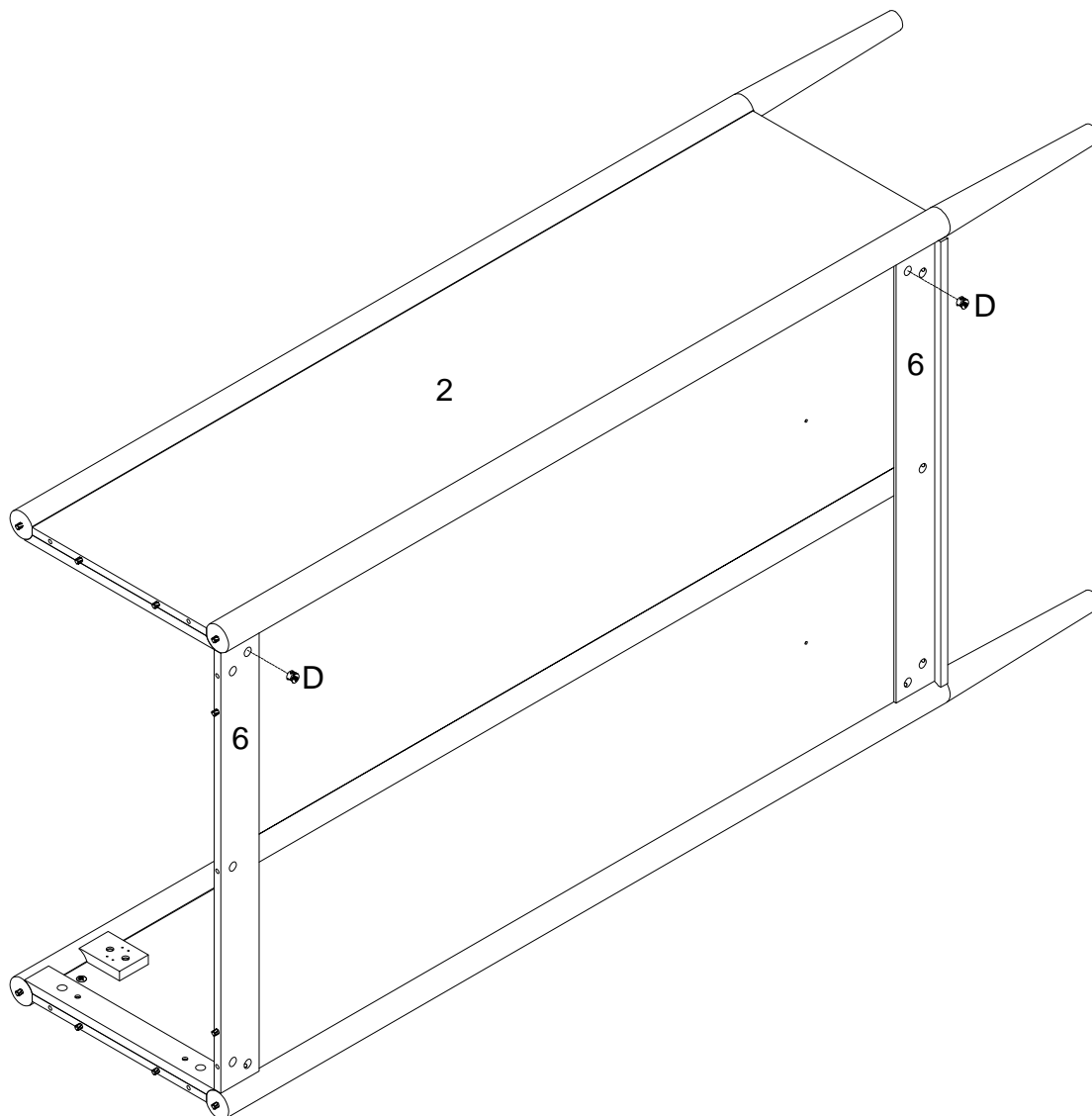

# Step 13

Screw cam bolts (C) into the Top Panel (1). Then, attach the door stopper (H) using the (J) screws.

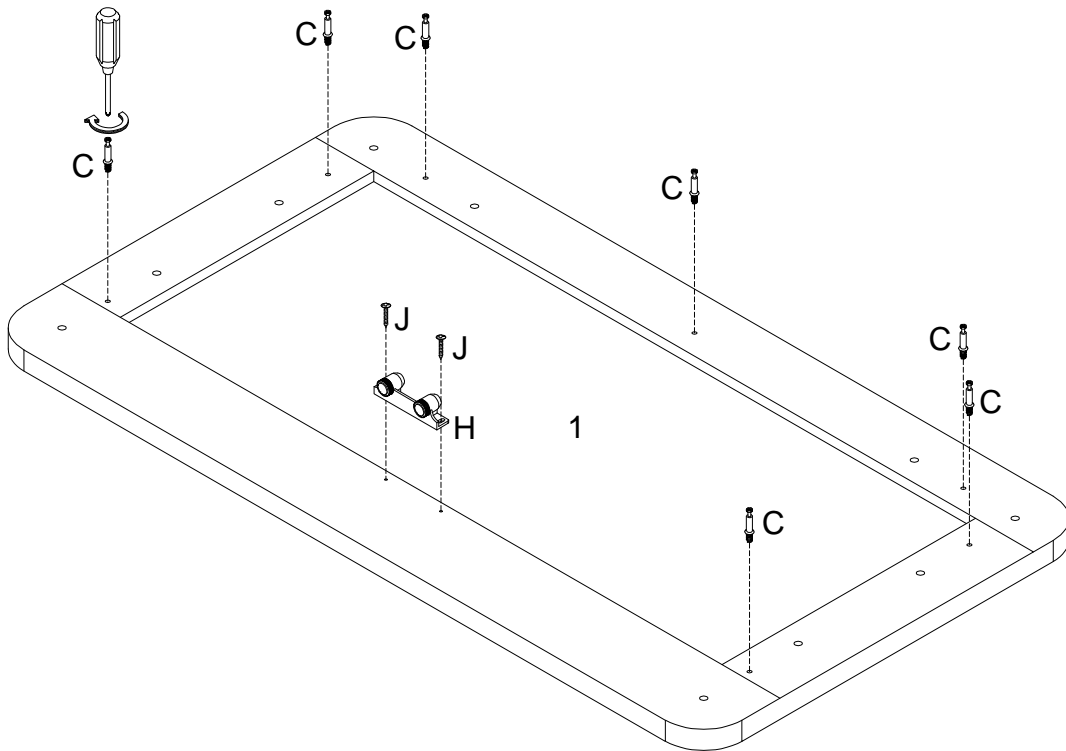

# Step 14

Secure the Top Panel (1) to the rest of the unit. Insert cam bolts (D) and tighten.

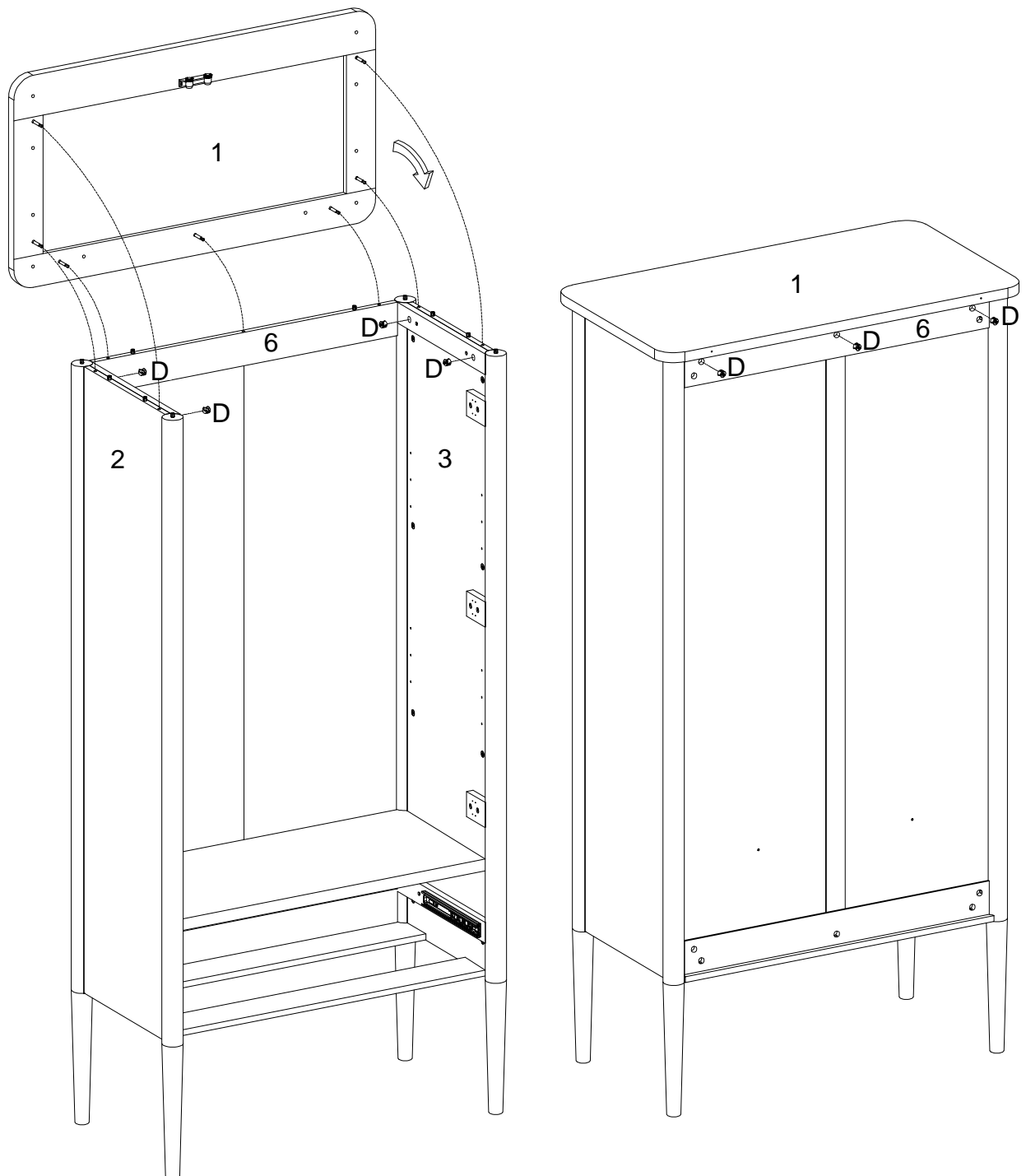

# Step 15

Use the provided stickers (E) to cover each cam lock (D), ensuring a clean finish.

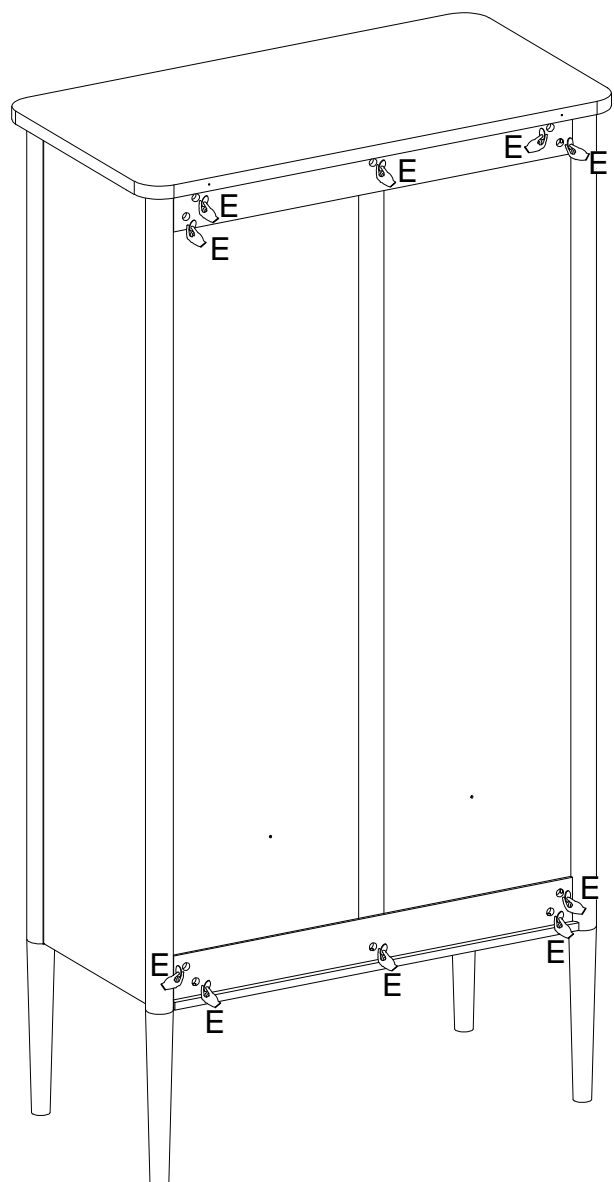
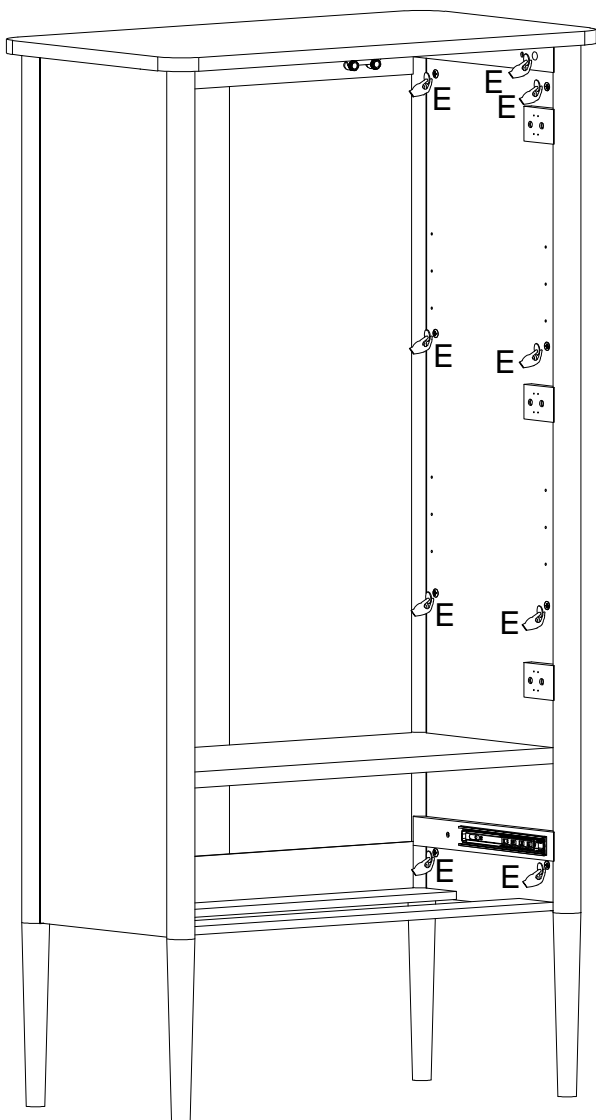

# Step 16

Insert plastic wedges (M) in between the Back Panel (9) and the frame of the unit. Secure the wedges in place with the (N) screws.

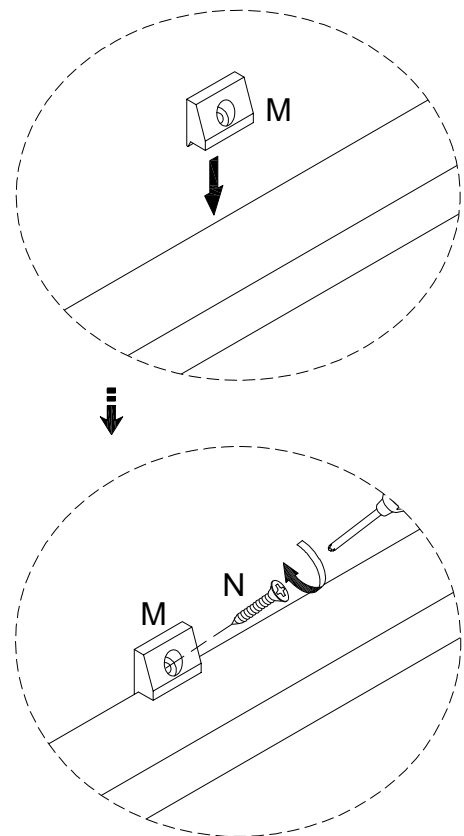
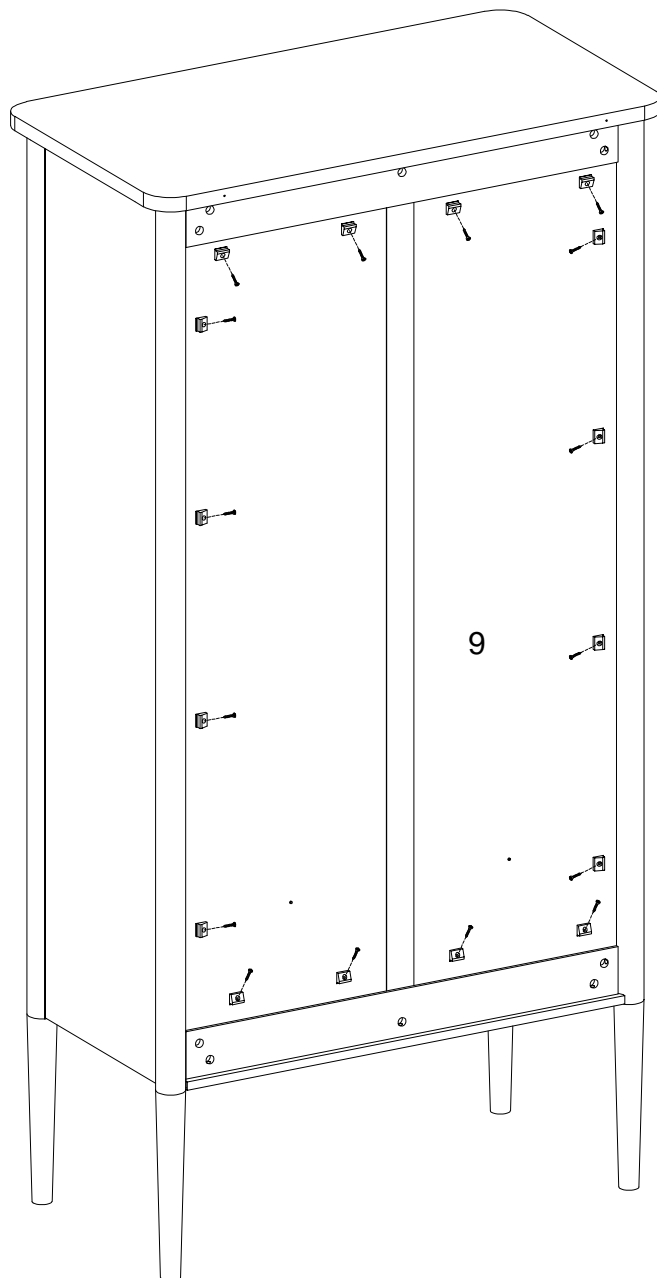

# Step 17

Screw the (T) screws into the Back Panel (9).

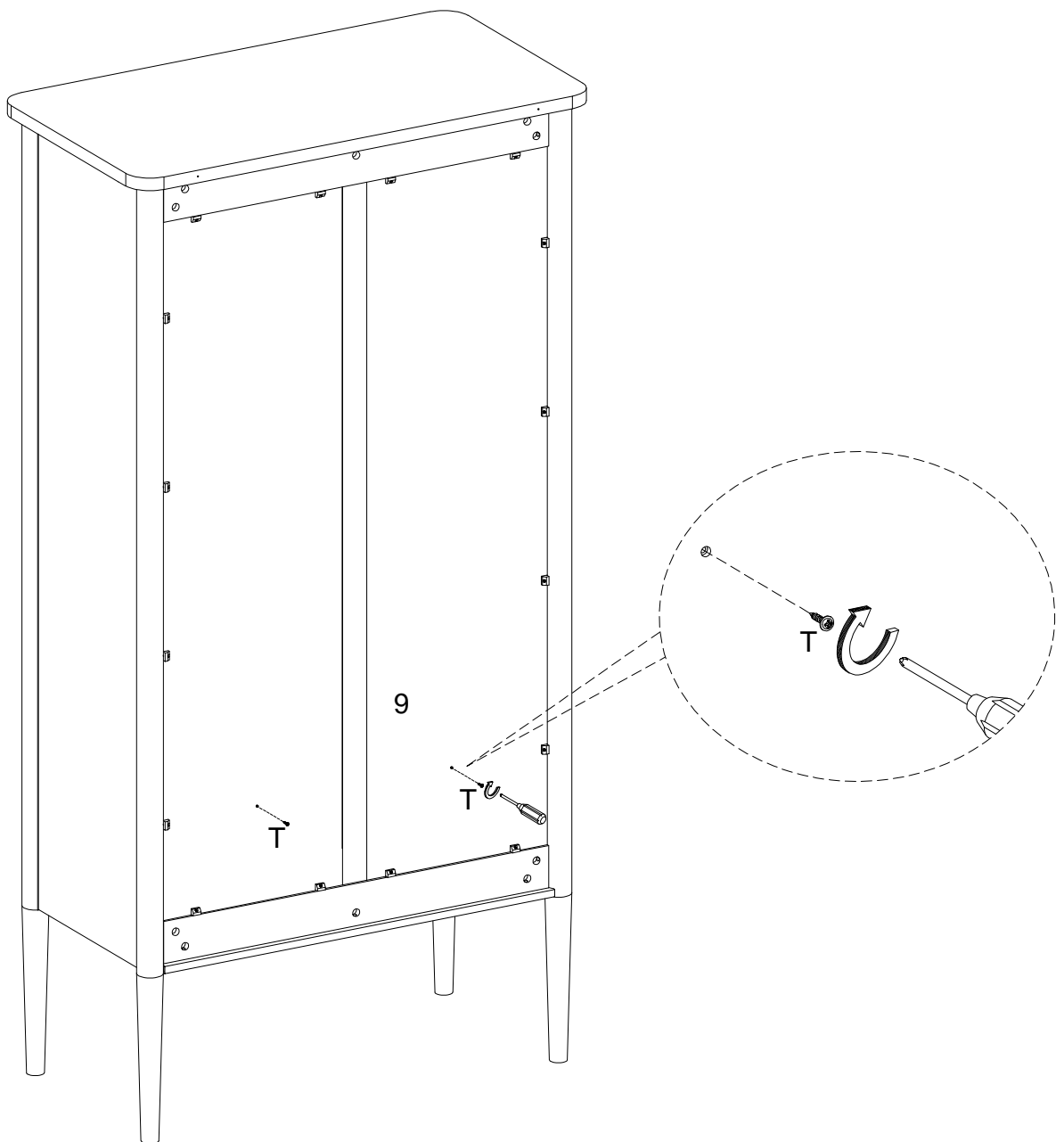

# Step 18

Insert shelf support pins (L) and then insert both Adjustable Shelves (8), making sure the notch in the shelves match up with your shelf support pins (L).

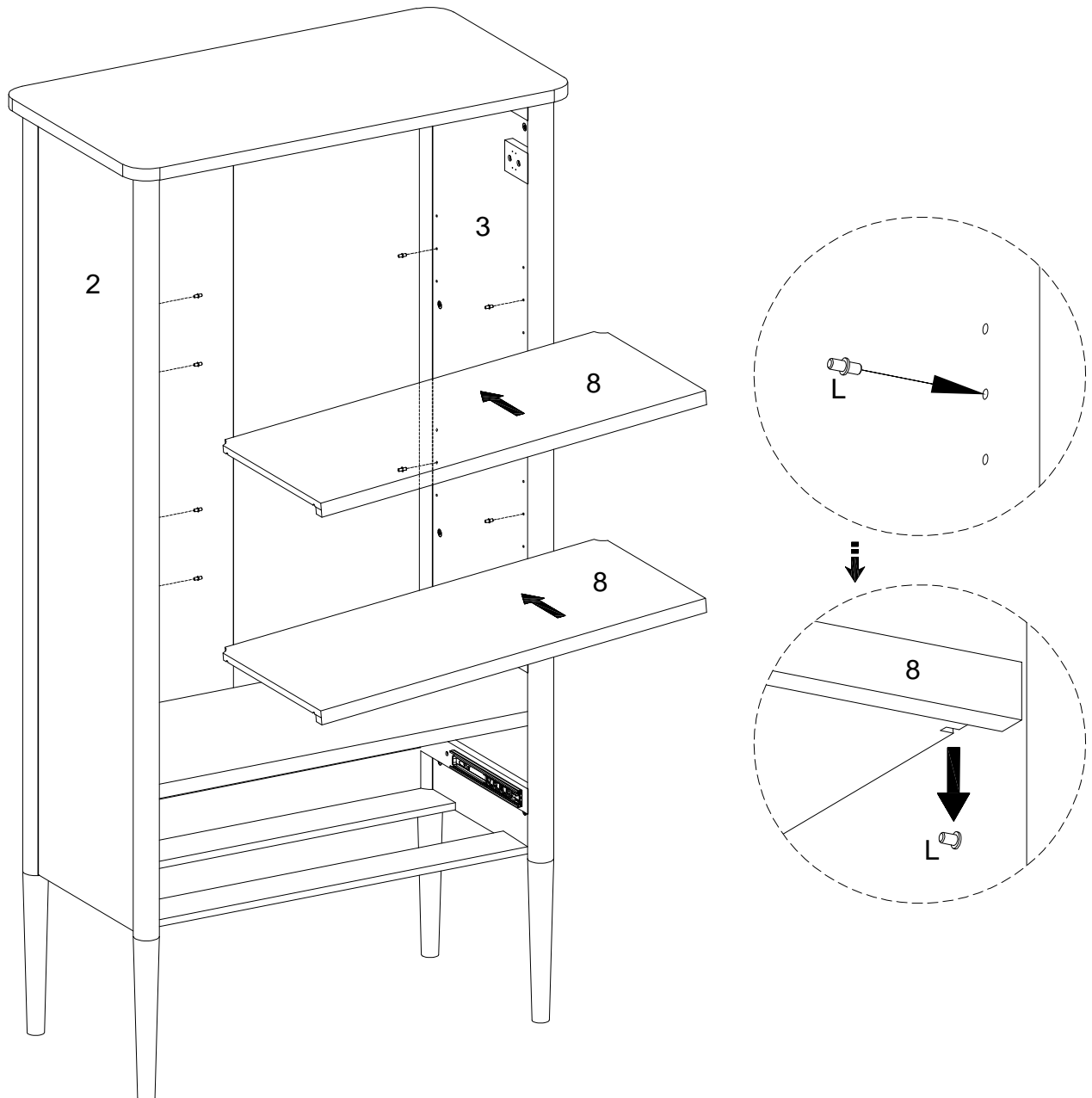

# Step 19

Stick the Rubber Pads (U) in place on the Fixed Divider (7).

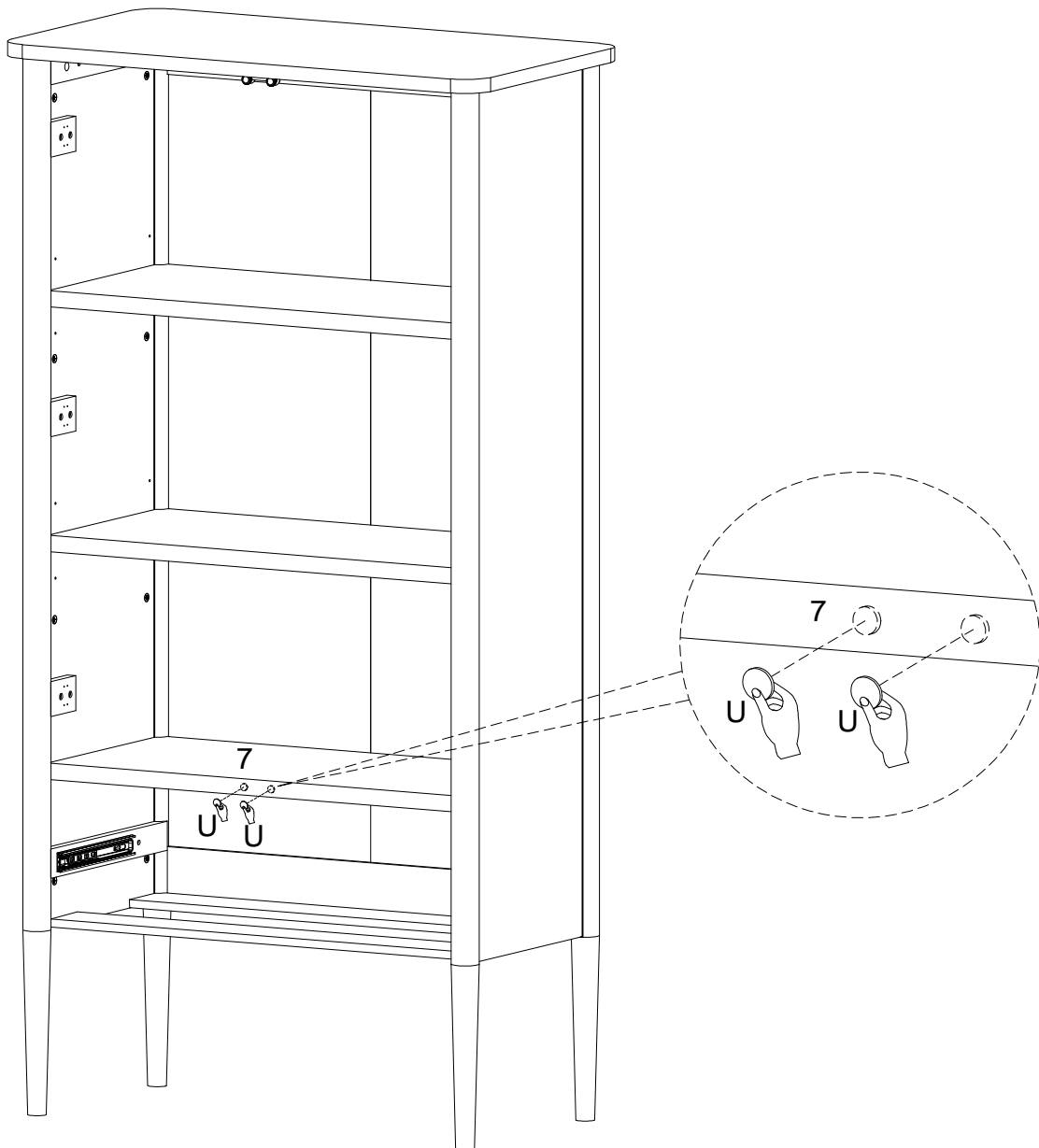

# Step 20

Insert a (K) bolt into the corner of the Left Door (10).  
Then, using the (G) screws, attach the hinges (F) to the  
Left Door (10). Next, attach a drawer handle (P) to each  
door using the (Q) Bolt.

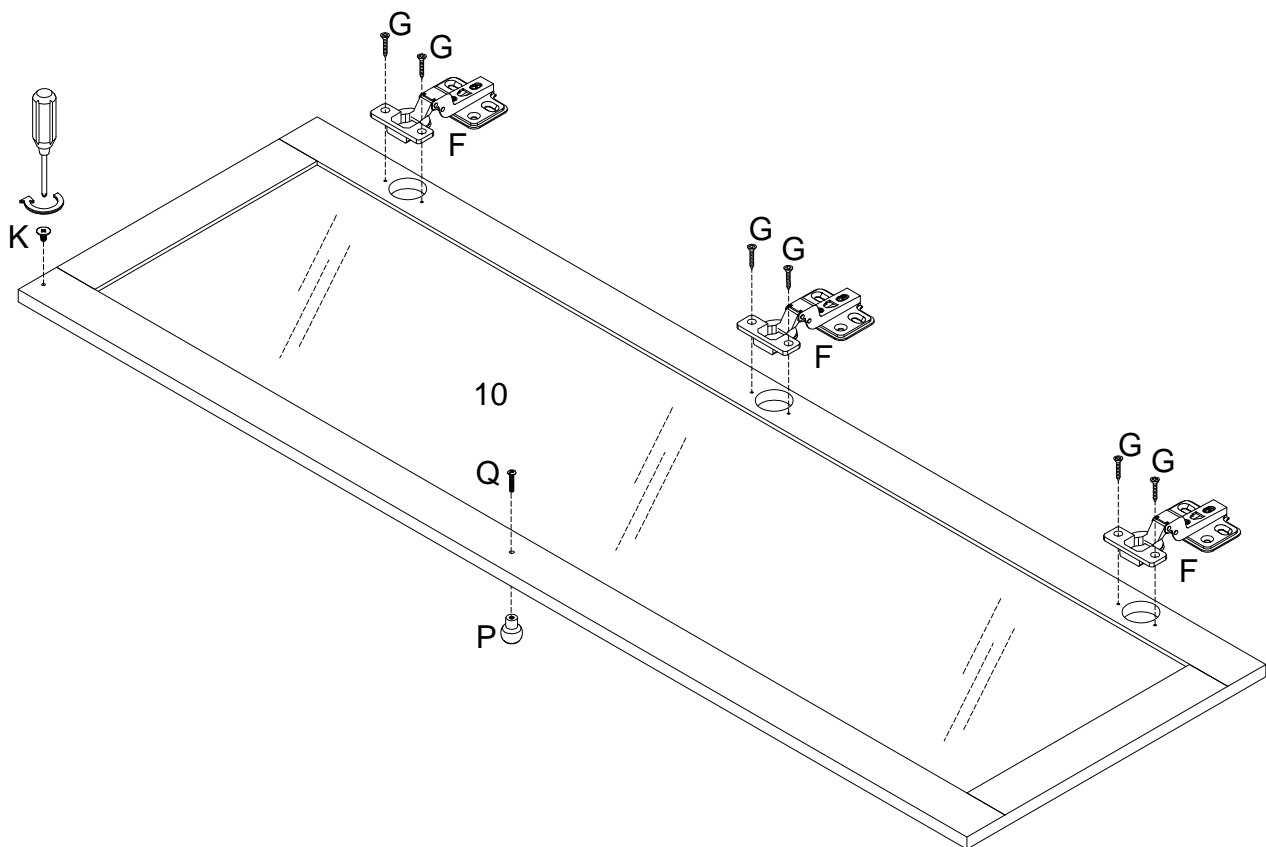

# Step 21

Insert a (K) bolt into the corner of the Right Door (11).  
Then, using the (G) screws, attach the hinges (F) to the  
Right Door (11). Next, attach a drawer handle (P) to each  
door using the (Q) Bolt.

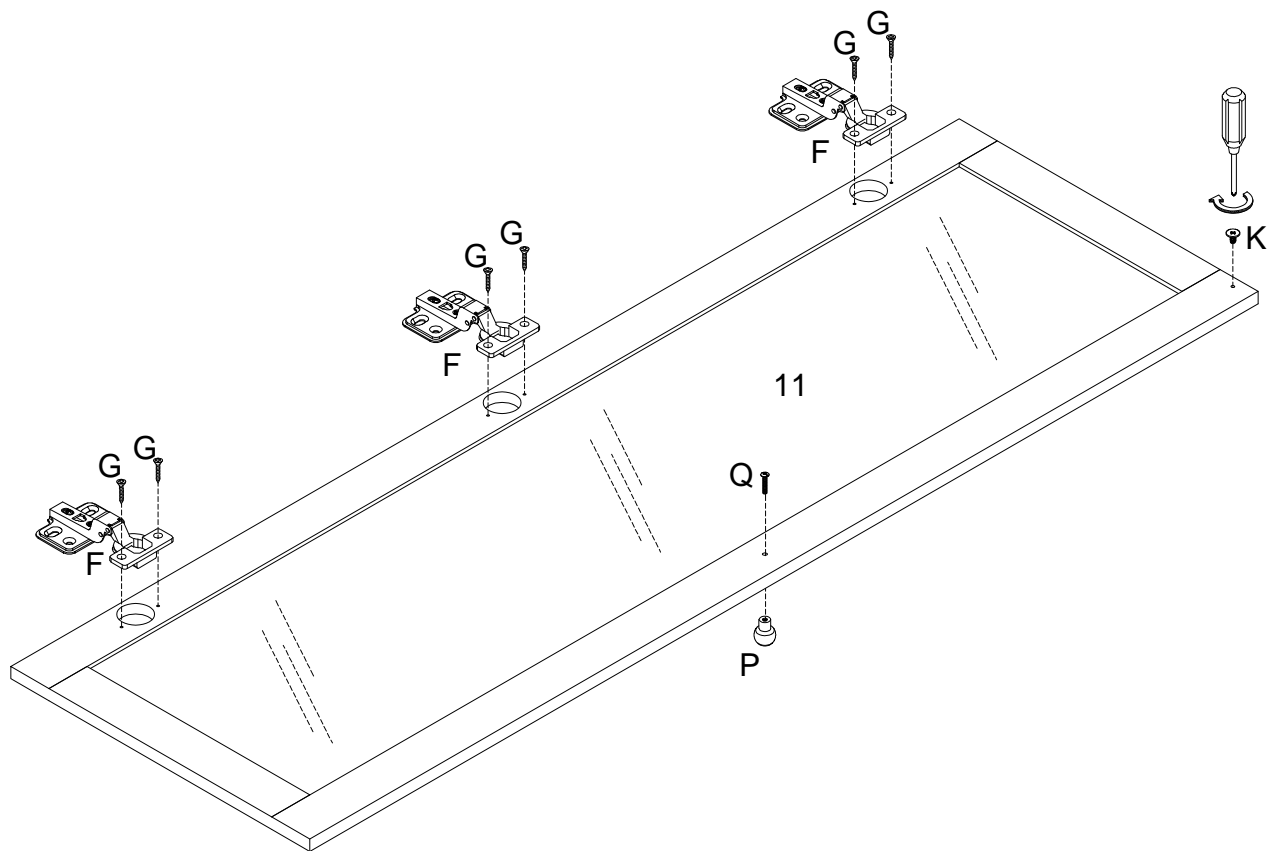

# Step 22

Secure the hinges (F) to the Left Panel (2) using the (G) screws.

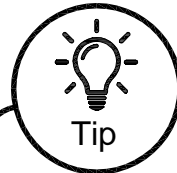
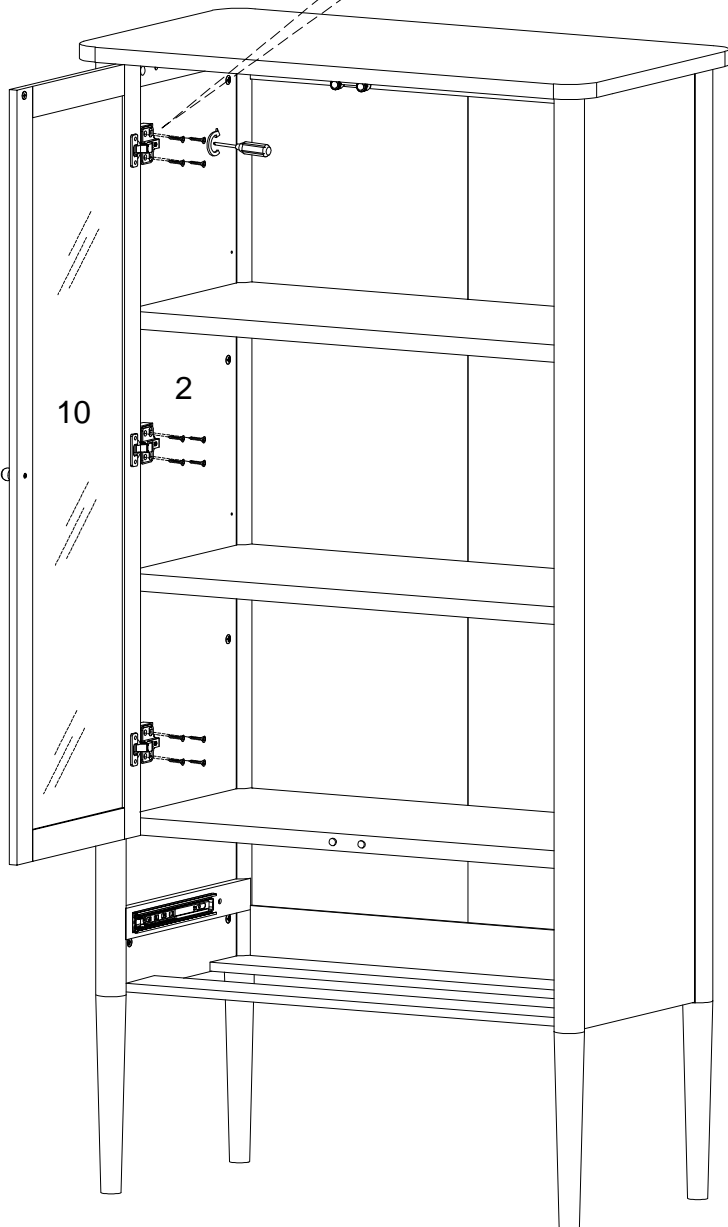
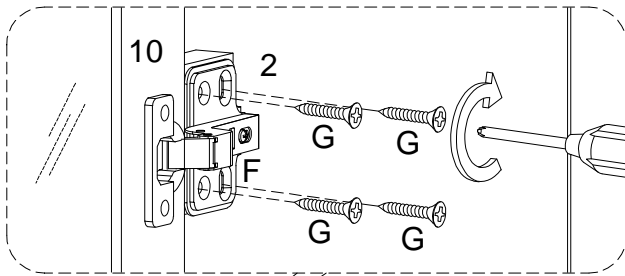

## Adjusting The Cabinet Doors

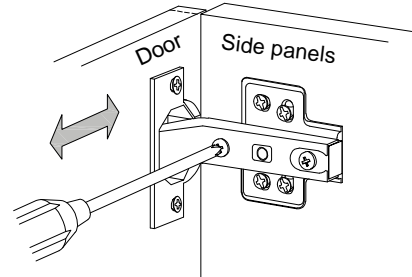

Adjust horizontal width with this screw.

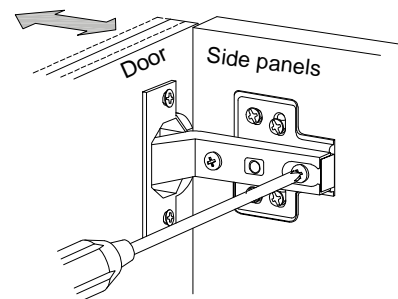

Adjust depth position by loosening the hinge arm mounting screw.

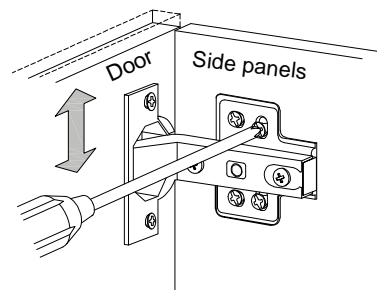

Adjust vertical height via the screws in the mounting plate.

# Step 23

Secure the hinges (F) to the Right Panel (3) using the (G) screws.

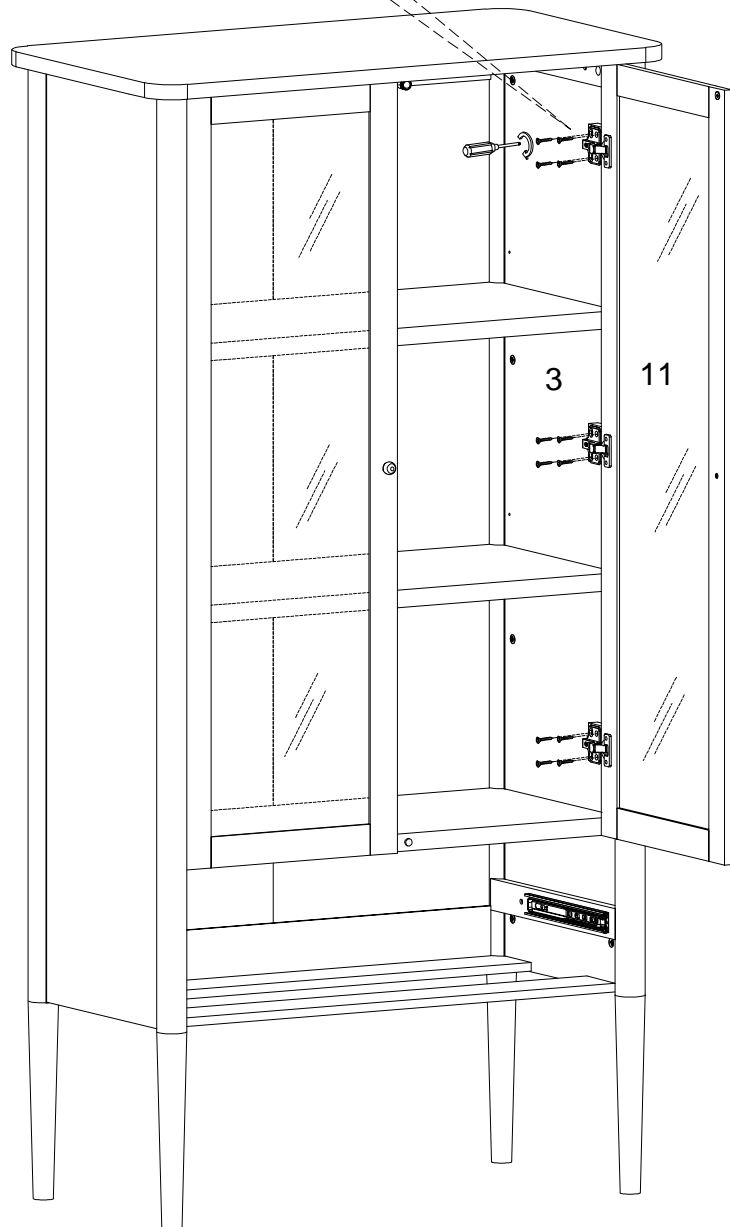
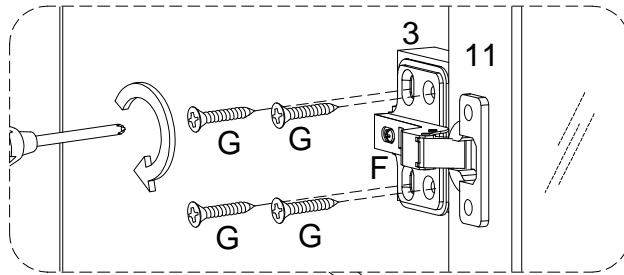

# Step 24

Attach the drawer side of the drawer glides (R) to the Drawer Left Panel (14) and the Drawer Right Panel (15) using the (S) screws.

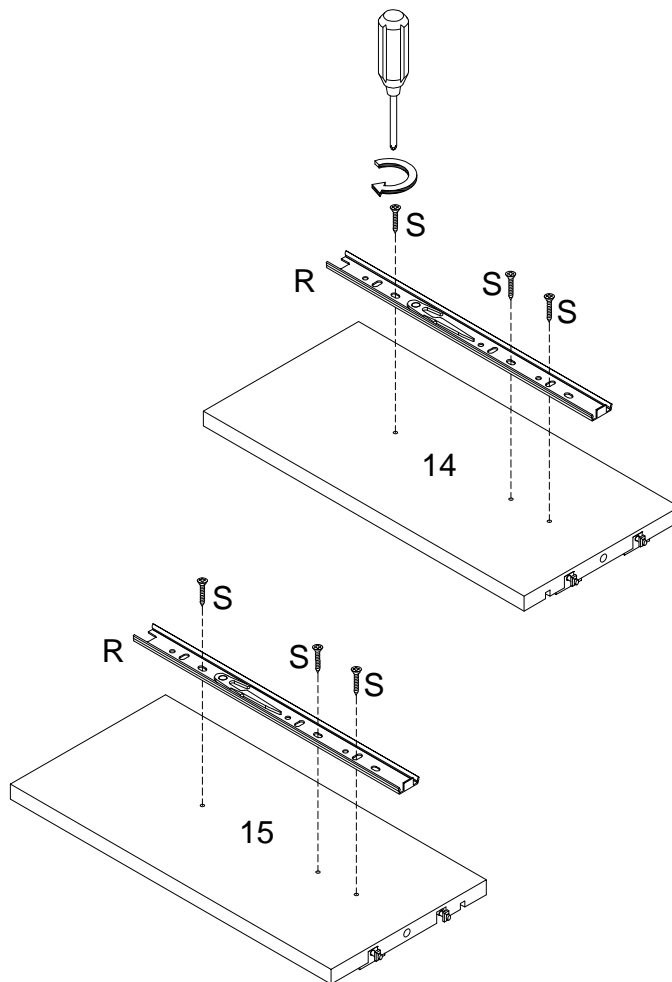

# Step 25

Insert wooden dowels (B) into the Drawer Right Panel (15), Drawer Left Panel (14), and the Drawer Back Panel (13).

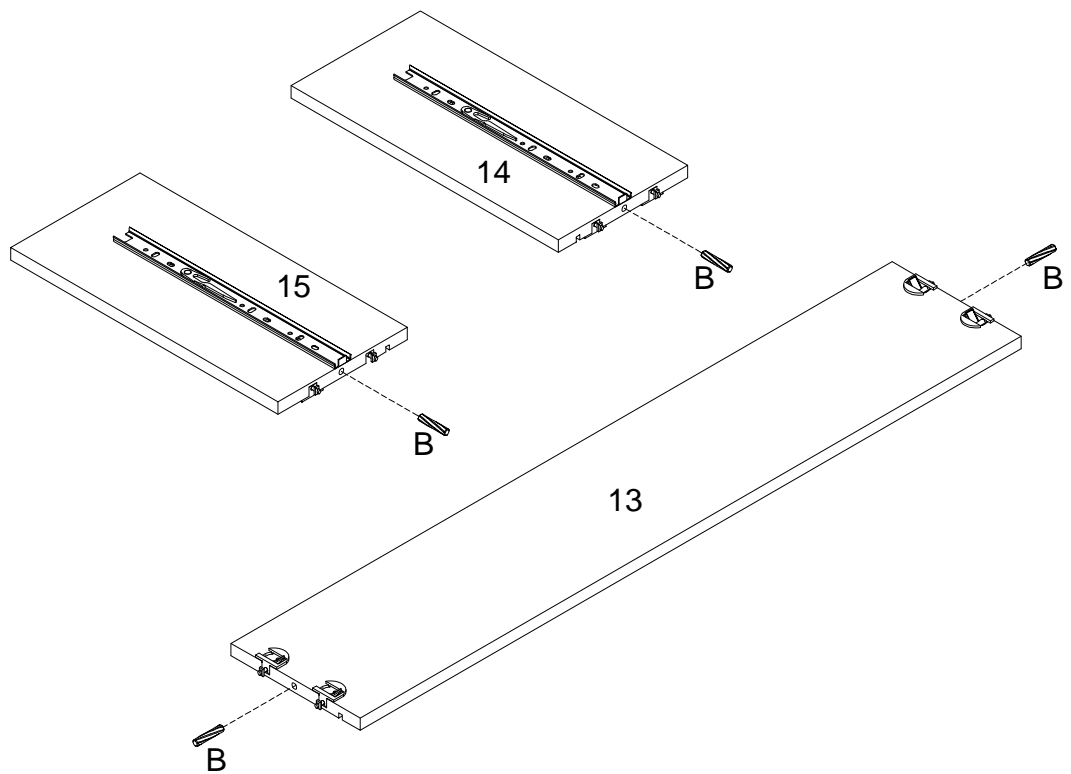

# Step 26

Using the quick assembly mechanism, attach the Drawer Right Panel (15) to the Drawer Back Panel (13).

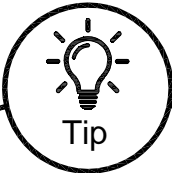
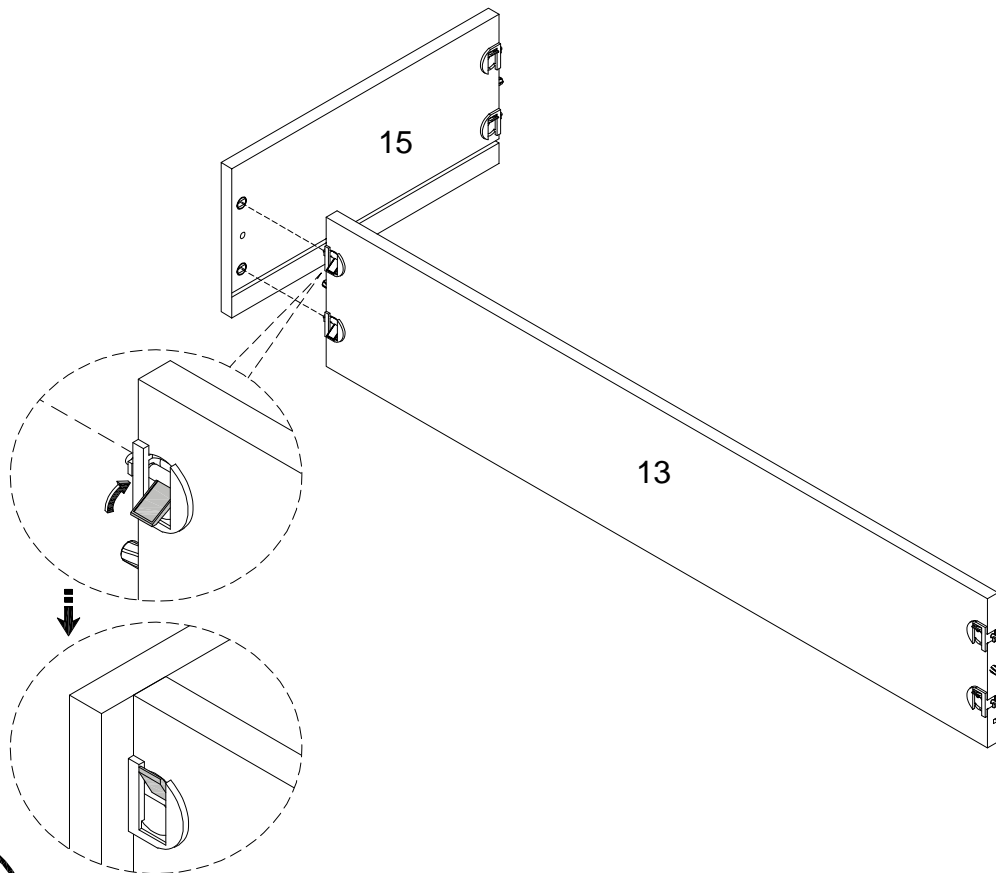

Tip

## Quick Assembly Drawers

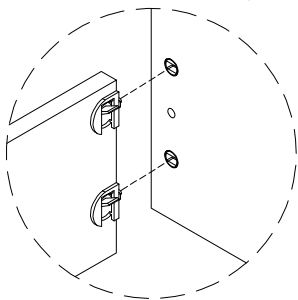

1. Make quick assembly drawer pin is aligned with corresponding hole

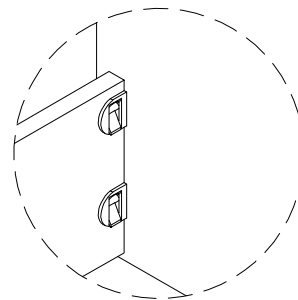

2. Once pin is inserted correctly flip metal lever in opposite direction to ensure panels are firmly locked together.

# Step 27

Using the quick assembly mechanism, attach the Drawer Left Panel (14) to the Drawer Back Panel (13).

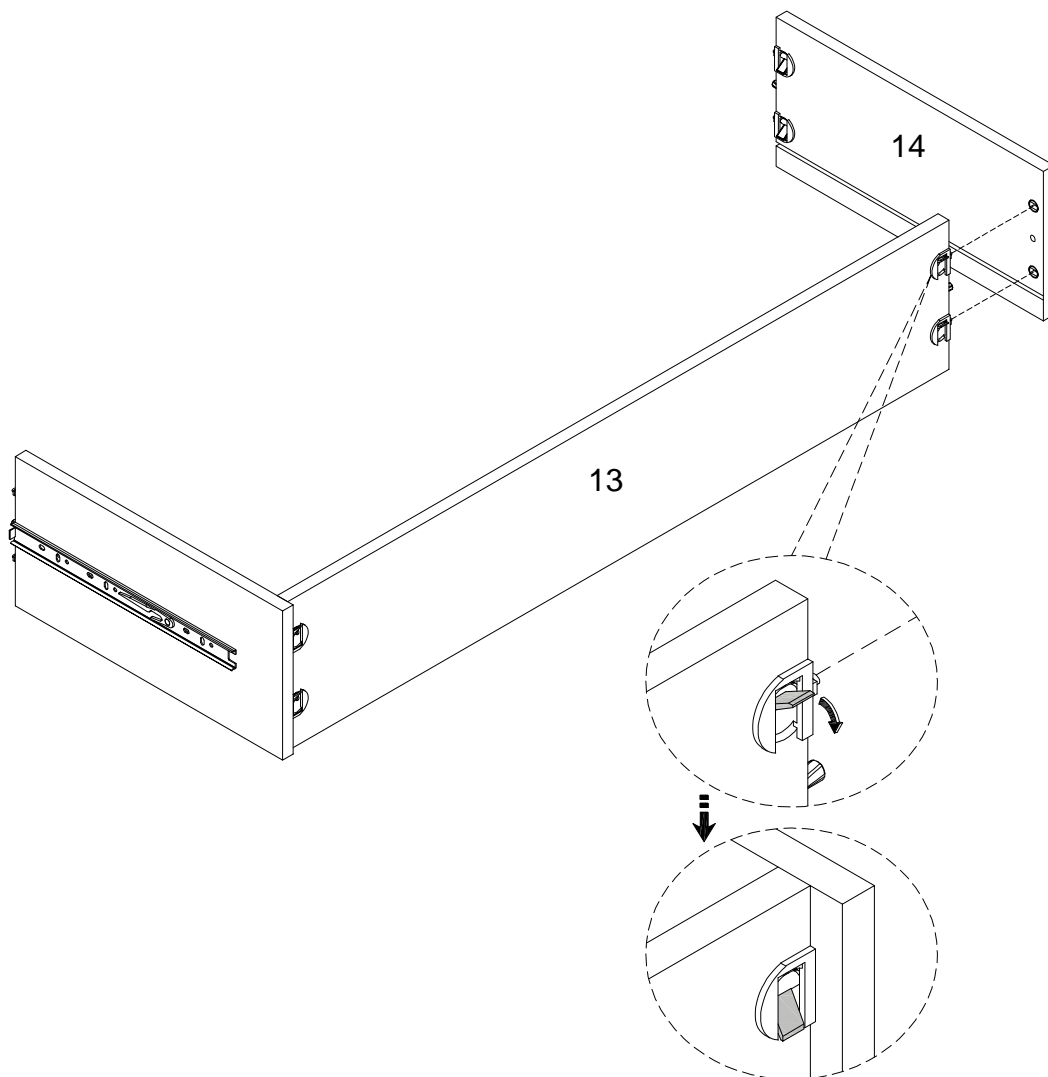

# Step 28

Insert the Bottom Drawer Panel (16) using the grooves as your guide.

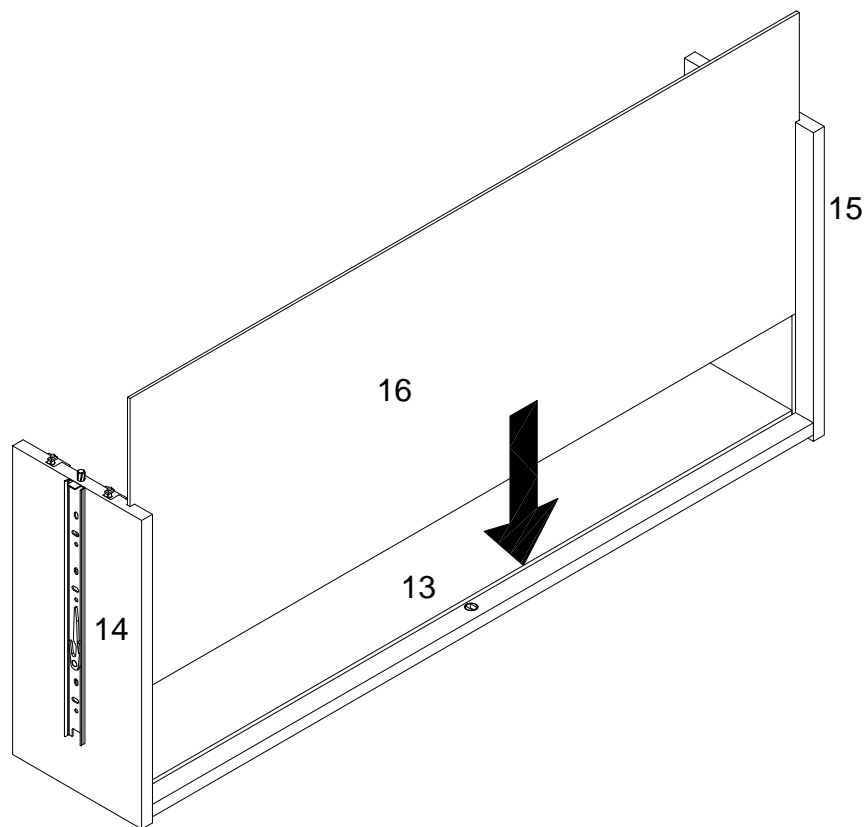

# Step 29

Attach the Drawer Support Panel (17) to the Drawer Back Panel (13) and secure by flipping the latch on the quick assembly mechanism.

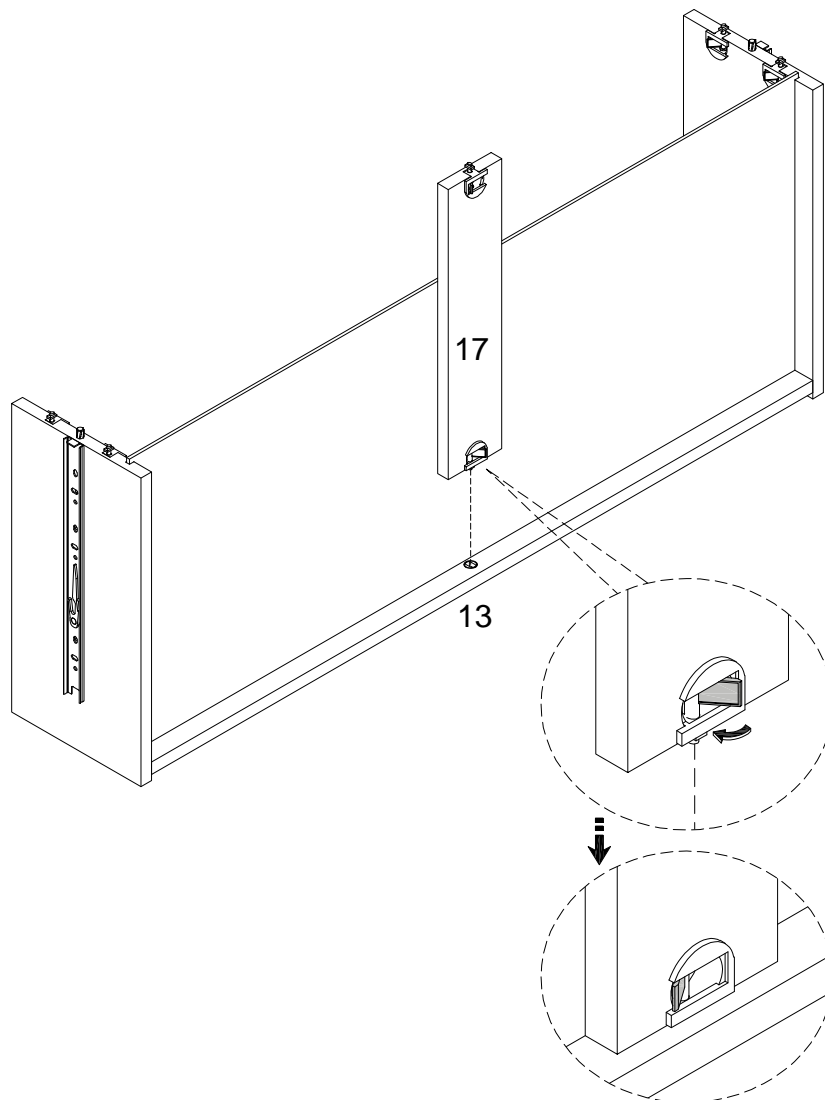

# Step 30

Attach the Drawer Front Panel (12) to the rest of the drawer and secure with the quick assembly mechanism.

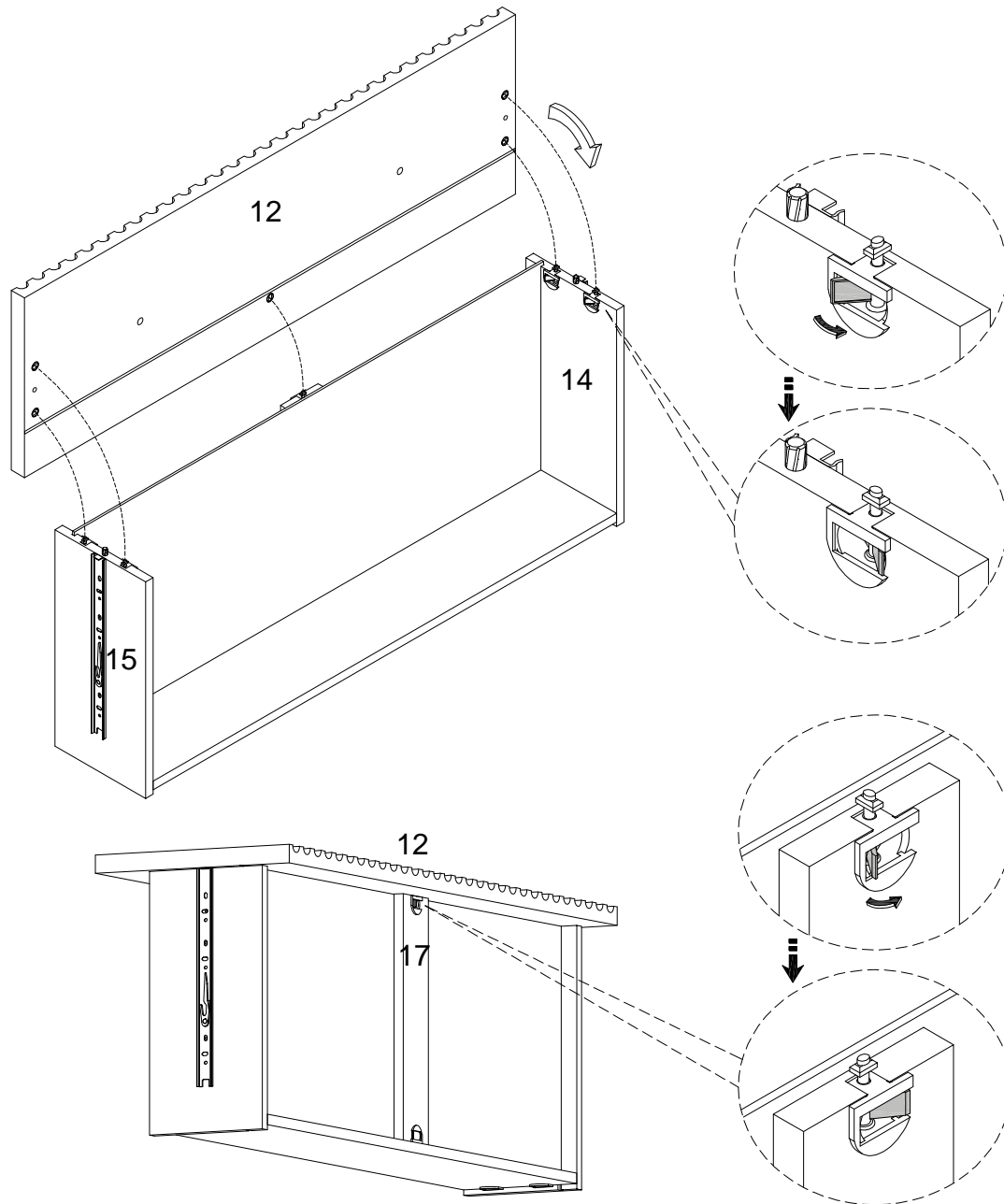

# Step 31

Now, attach Handle (P) to the drawer using the (Q) bolts.

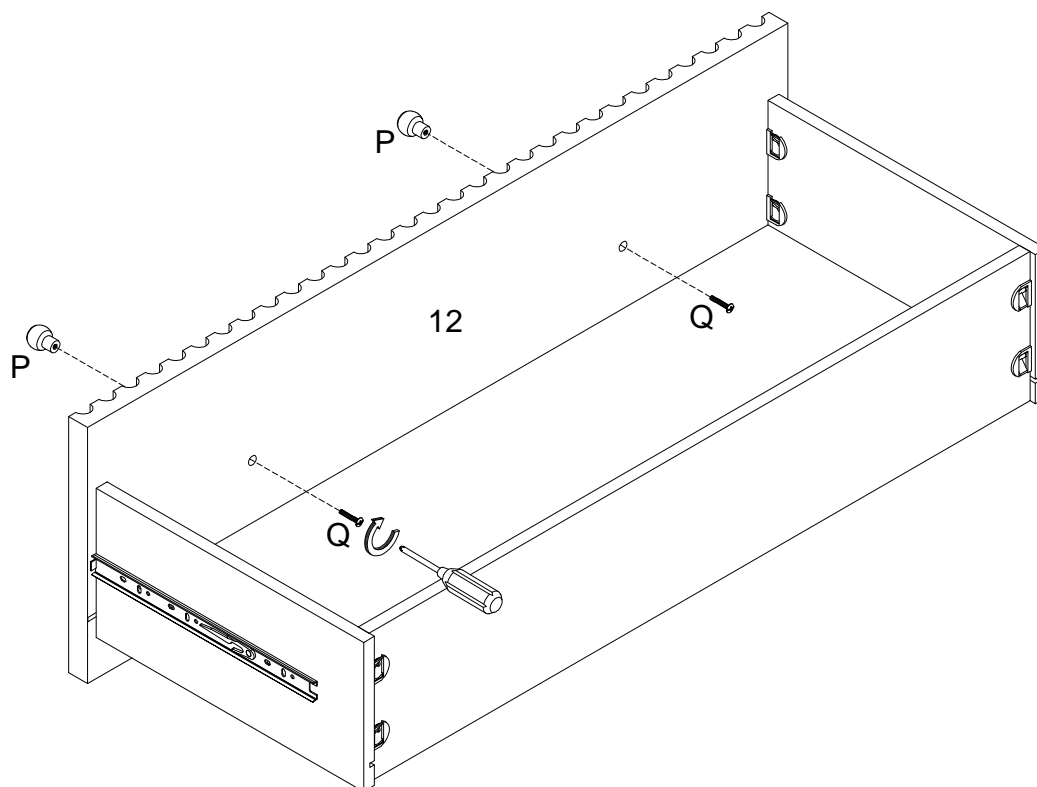

# Step 32

Firmly push the drawer all the way into place making sure the drawer member lines up with the inside guides of the cabinet member. Some resistance is normal.



Tip

## Reinserting your Cabinet Glides together

Line up the Drawer Member so it is inside the guides of the Cabinet Member. Once the connection is made, push the drawer into place entirely. It may not be a smooth glide on your first try, but will improve after it's fully inserted.

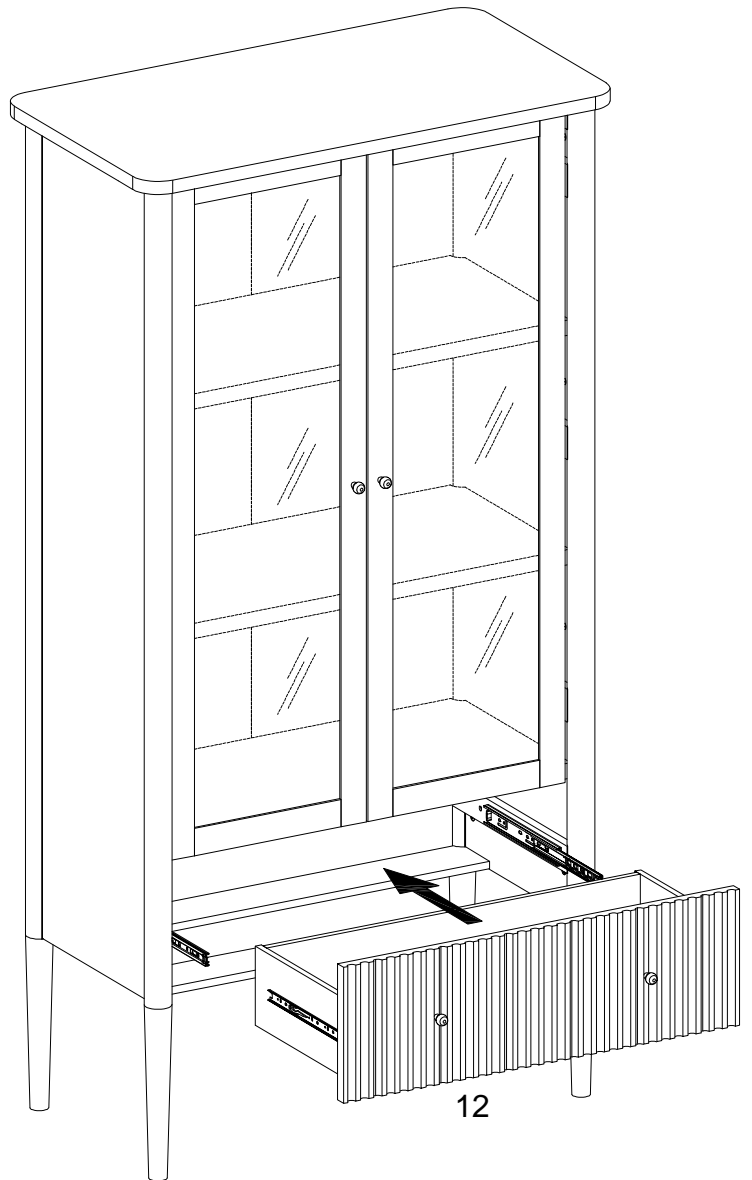
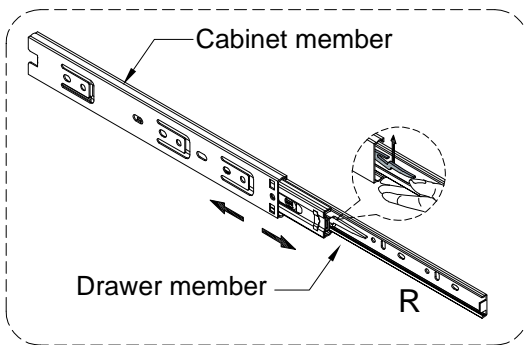

# Step 33

Attach the plastic strap (X) to the back of the unit using the (V) screws.

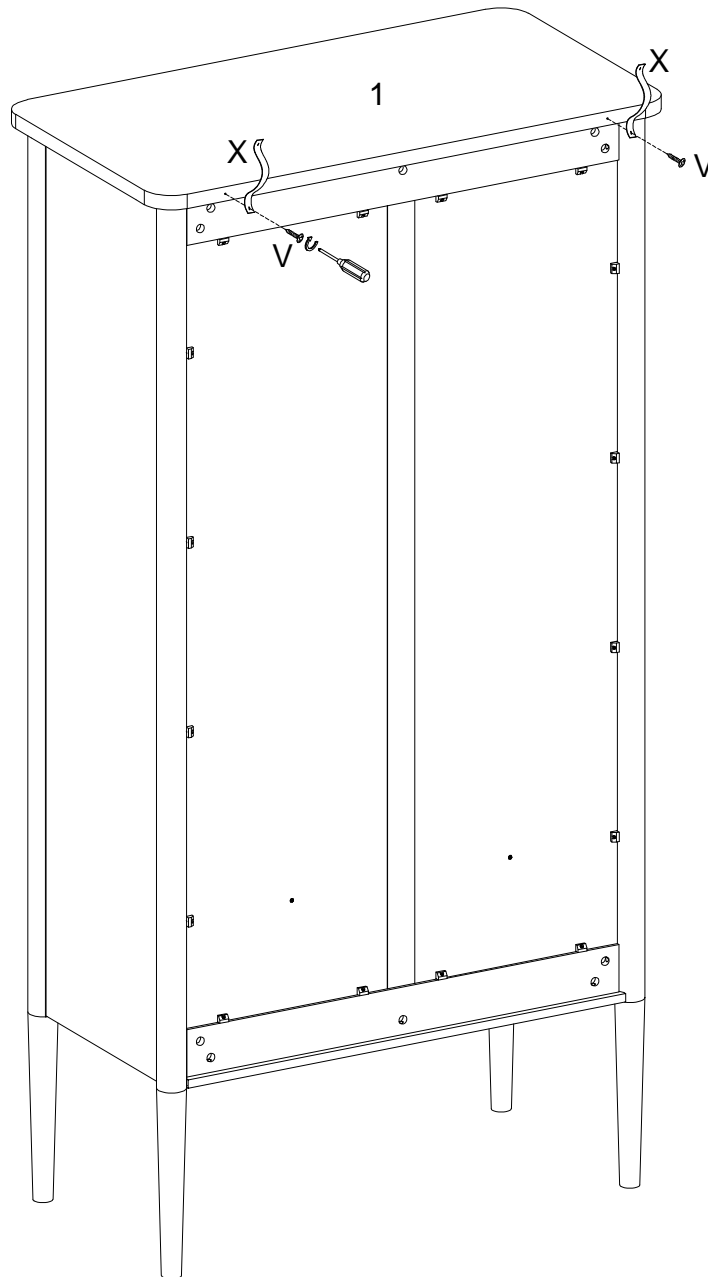

# Step 34

Secure your unit to the wall using the (W) screw, plastic strap (X), and the wall anchor (Y).

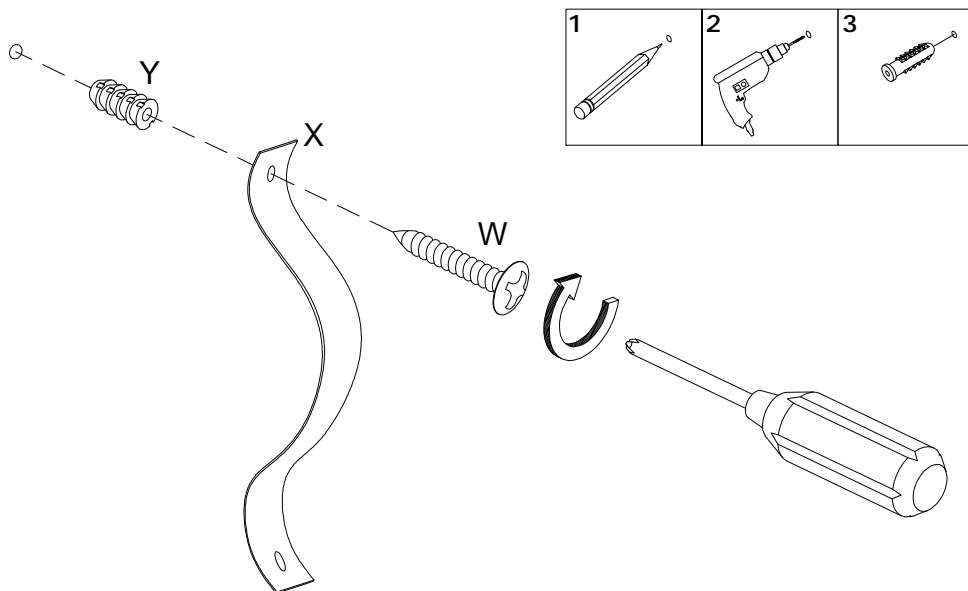

## Warning

Serious or fatal injuries can occur from furniture tipping over. To prevent the furniture from tipping over we recommend that it is permanently fixed to the wall. Wall anchor and hardware are included with this product. Please make sure hardware is suitable for your walls before installing, as different wall materials may require different types of anchors.

# Final Assembly

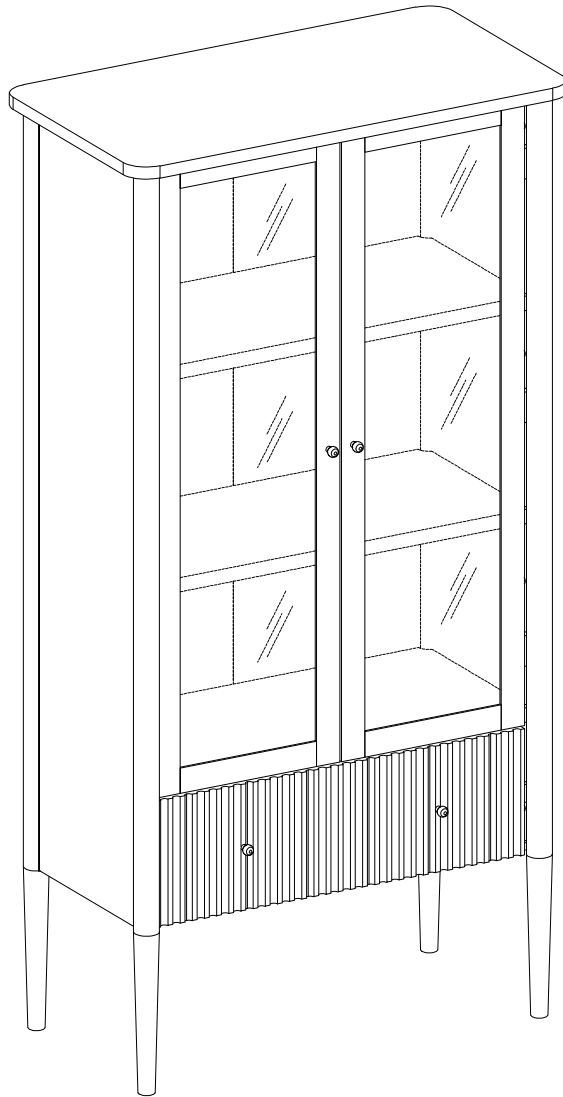

**Congratulations on your new piece of furniture!**

We would love to hear about it and see it.  
Please leave us a review or post a picture with  
**#mywalkerredisonhome**

# Assembling furniture can be tricky sometimes.

Our customer service team, located in Utah, is here for product information, help assembling a product, or for any other customer support issue

Call us at **801-433-3008**

Email us at [service@walkeredison.com](mailto:service@walkeredison.com)

Visit our Customer Service website at  
[walkeredison.com/pages/customer-service](http://walkeredison.com/pages/customer-service)

We are available to help Monday -Thursday 8am-5pm, Friday  
8am-3pm MST

For details on Assembly Videos, Assembly Instructions,  
Replacement Parts, and Customer service,

**SCAN HERE**

