

# ASSEMBLY INSTRUCTIONS ( 3 DRAWER CHEST )

---

~ Before assembly, please read the instructions ~ ~ Follow these steps to assemble the Chest Cabinet ~  
~ Keep these instructions for future reference ~

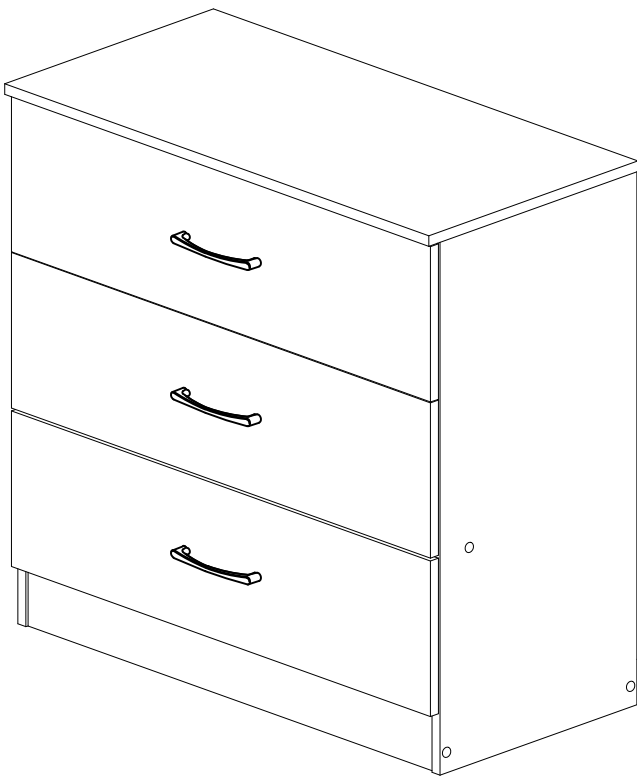

FRONT VIEW

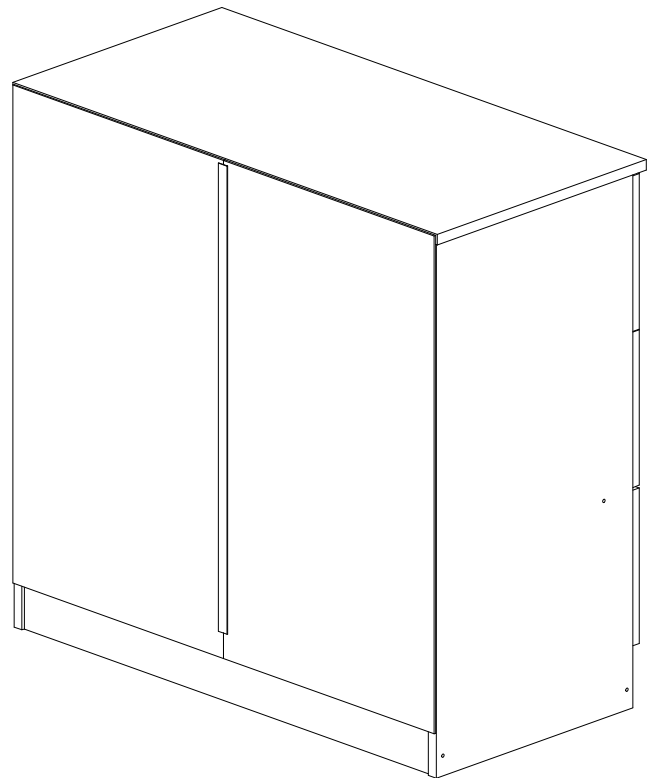

BACK VIEW



THIS INSTRUCTION BOOKLET CONTAINS IMPORTANT INFORMATION ABOUT ASSEMBLY AND SAFETY. PLEASE READ AND KEEP FOR FUTURE REFERENCE.

- This product contains small components, please ensure that they are kept away from small children.
- THIS INSTRUCTION BOOKLET CONTAINS **IMPORTANT** SAFETY INFORMATION. PLEASE READ AND KEEP FOR FUTURE REFERENCE.



**DO NOT RETURN PRODUCT TO THE STORE.**

If a part is missing or damaged, email our customer service. We will gladly ship your replacement parts FREE of charge.

Need Parts or Assistance?

email us

For prompt, reliable service; please have your assembly manual ready.

# Parts

**A Left Side Panel**  
1 Pc.  
762 x 371 x 15mm

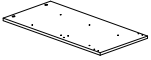

**B Kick Panels (Front&Back)**  
2 Pcs.  
766 x 90 x 15mm

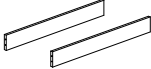

**C Front Strengthening Panel**  
1 Pc.  
766 x 76 x 15mm



**D Right Side Panel**  
1 Pc.  
762 x 371 x 15mm

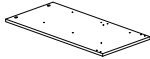

**E Top Panel**  
1 Pc.  
800 x 394 x 15mm

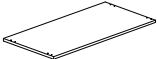

**F Back Panels**  
2 Pcs.  
711 x 397 x 3mm

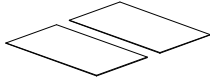

**G Drawer Front Panels**  
3 Pcs.  
790 x 222 x 15mm

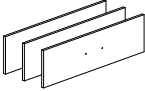

**H Drawer - Left Side Panels**  
3 Pcs.  
338 x 140 x 15mm



**I Drawer - Right Side Panels**  
3 Pcs.  
338 x 140 x 15mm



**J Drawer End Panels**  
3 Pcs.  
711 x 140 x 15mm

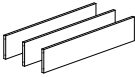

**K Drawer Base Panels**  
3 Pcs.  
740 x 343 x 3mm

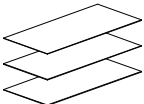

**L Drawer Support Panels**  
3 Pcs.  
338 x 56 x 15 mm





The parts of the product are packed in one box.  
There are inner box(es) or package(s) that included components and accessories required to complete the assembly

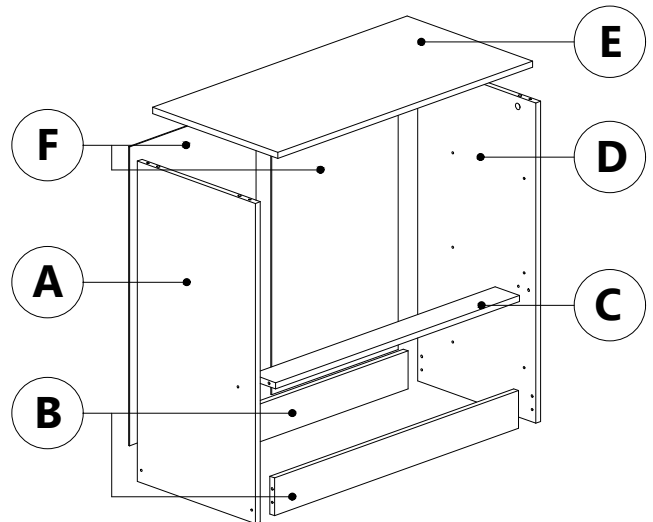



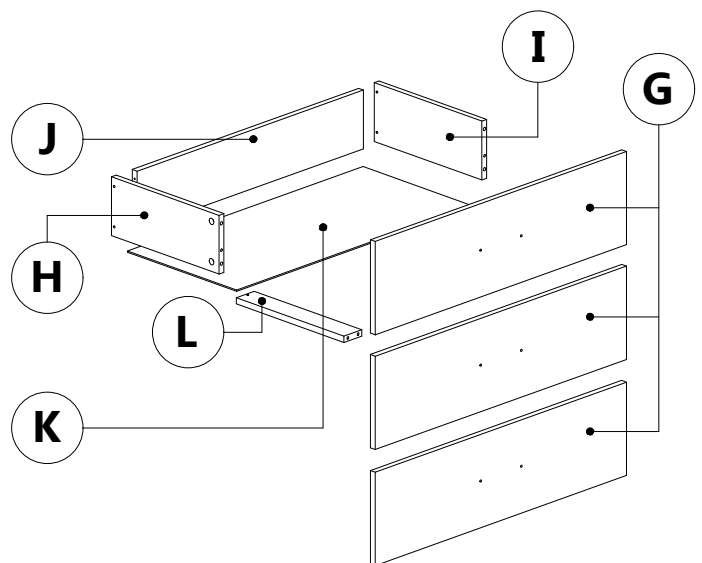





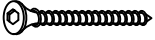

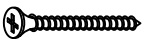



## I) Main Unit :



## II) Drawer :



# Hardwares And Accessories

<p><b>1</b> Screw M6 x 40mm 6 Pcs.</p>  <p><b>Pvc Cap</b> 6 Pcs.</p> 	<p><b>2</b> Screw M4 x 32mm 15 Pcs.</p> 	<p><b>3</b> Screw M3.5 x 14mm 18 Pcs.</p>  <p>* For # <b>12</b> Drawer Slides</p>	<p><b>4</b> Handle 3 Pcs.</p>  <p><b>Screw M4 X 32mm</b> 6Pcs.</p> 	<p><b>5</b> Mini Fix 16 Sets.</p>  <p><b>Pvc Cap</b> 16 Pcs.</p> 
<p><b>6</b> Pvc Dowel 22 Pcs.</p> 	<p><b>7</b> Protection Nail 4 Pcs.</p> 	<p><b>8</b> Nail 40 Pcs.</p> 	<p><b>9</b> Allen Key 1 Pc.</p> 	<p><b>10</b> Screw M6.2 x 10mm 12 Pcs.</p>  <p>* For # <b>11</b> Drawer Slides</p>
<p><b>11</b> Drawer Slide - A 3 Pcs.</p>  <p>* Fix On Side Panels <b>A</b> &amp; <b>D</b></p>	<p><b>12</b> Drawer Slide - B 3 Pcs.</p>  <p>* Fix On Drawer Side Panels</p>	<p><b>13</b> H-PROFILE 1 Pc.</p> 		





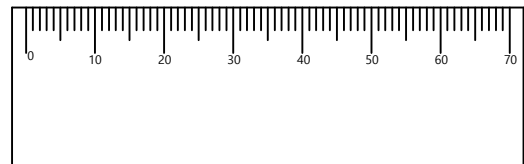

## IMPORTANT

Check the measure of the bolts on the scale below or with a measuring tape before applying them in the parts

Observe correctly the application and the position of each bolt accessory, as the step-by-step instructions, before applying them in the parts.



# Required Or Recommended Tools

<p>Sample Screwdriver</p> 	<p>Sample Hammer</p> 	<p>Sample Measuring Tape</p> 	<p>Sample Electric Screwdriver</p> 
---	--	--	--



## IMPORTANT!

The required or recommended tools for assembly are not supplied with the product.

Thank you for purchasing

### **READ BEFORE BEGINNING ASSEMBLY**

- Read each step carefully. It is very important that each step of instruction is performed in the correct order. If these steps are not followed in sequence, assembly difficulties will occur.
- Make sure all parts are included. Most parts are labelled or stamped on the raw edge.
- Work in spacious area, preferably on a carpet, near the place the unit will be used.
- Do not use power tools to assemble your furniture. Power tools may strip or damage the parts.

### **HELPFUL HINTS**

- Call us if you need assistance.
- Move your new furniture carefully, with two people lift and carry the unit to it's new location.
- Never push, drag or pull your furniture (especially on carpet).

### **Warranty Information**

We warrant this product to be free from defects in material and workmanship agrees to remedy any such defect. This warranty covers one year from the date of original purchase. This is solely limited to be repair or replacement of defective parts and no assembly labor is included.

This warranty does not apply to any product which has been improperly assembled, subjected to misuse or abuse or which has been altered or repaired in any way.

To obtain warranty service, purchaser must present original bill of sale. Components repaired or replaced warranted through the remainder of the original warranty period only. The defective components will be repaired or replaced without charge, subject to the terms and conditions described above.

**For help with assembly, identifying parts, product information or to order parts, please contact us**

## Pre - Assembly

Insert the mini fix ⑤ (nuts) with the cross arrow mark facing upward and aim to panel A 's top thru holes. (As shown)

Place the drawer slide A ⑪ onto the 2 holes area shown at left side panel A. Then tighten it with 2 screws ⑩. Do the same for the 3 other slide A ⑪.

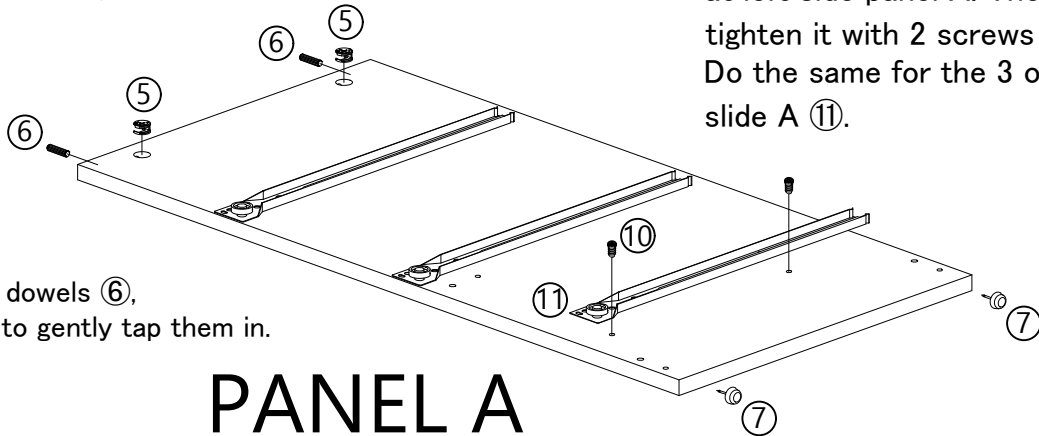

Insert the pvc dowels ⑥, using hammer to gently tap them in.

### PANEL A

Nail Protection Nail ⑦, provided with hammer onto the bottom edge of panel A as shown.

Insert the mini fix ⑤ (nuts) with the cross arrow mark facing upward and aim to panel D 's top thru holes. (As shown)

Place the drawer slide A ⑪ onto the 2 holes area shown at left side panel D. Then tighten it with 2 screws ⑩. Do the same for the 3 other slide A ⑪.

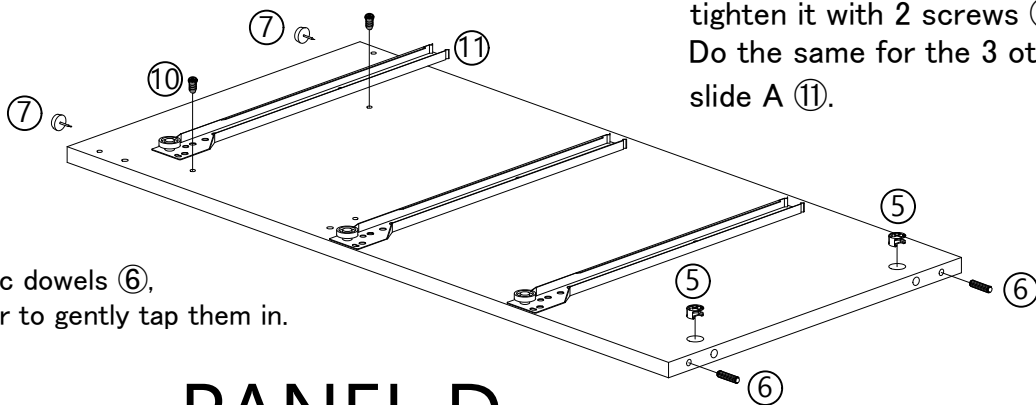

Insert the pvc dowels ⑥, using hammer to gently tap them in.

### PANEL D

Nail Protection Nail ⑦, provided with hammer onto the bottom edge of panel D as shown.

## Pre - Assembly

Insert the pvc dowels ⑥ to both end of the panels B and C. Using hammer to gently tap them in.

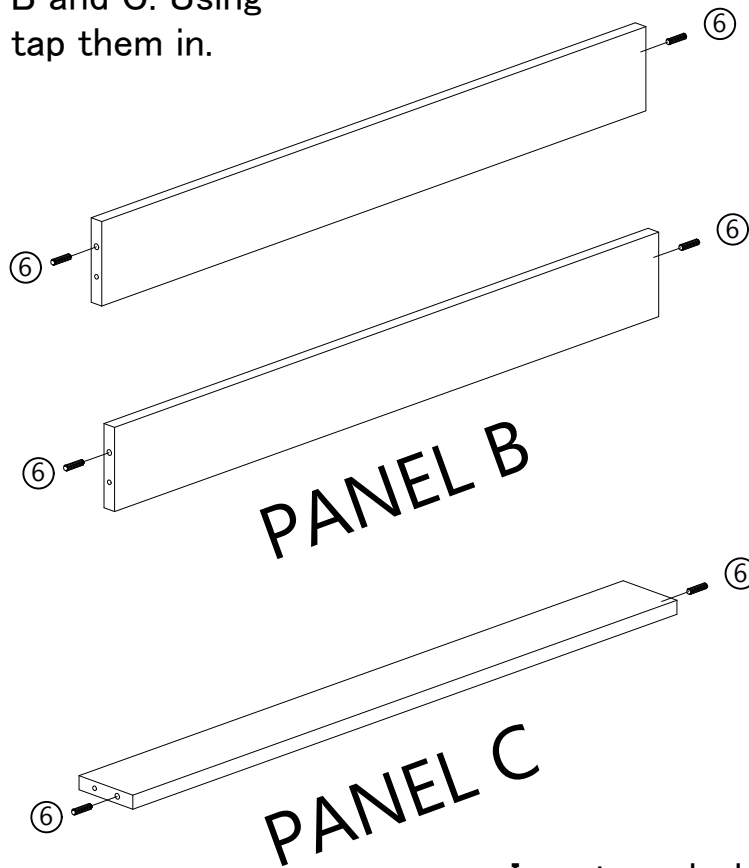

Insert, push down and tighten mini fix screw ⑤, to the non-thru hole as shown, 4pcs.

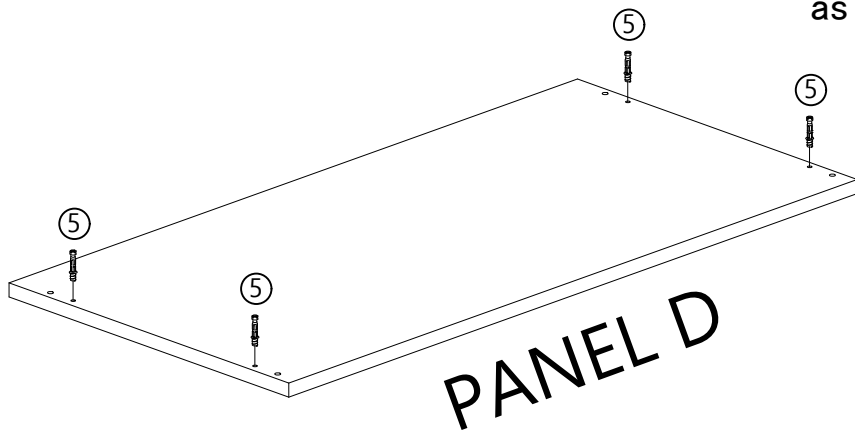

## Assembly Of Drawers : 3 DRAWERS

(1)

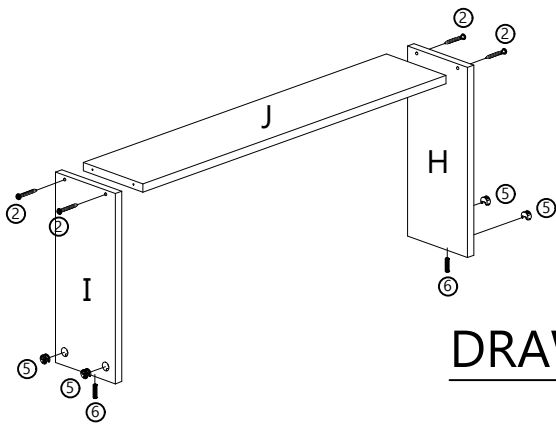

DRAWER G

Insert the minifix (5) (nuts) with the cross arrow mark facing downward and aim to panel H and I's lower thru holes. (As shown)  
 Insert the PVC dowels (6) to end of the panels H to I. Using hammer to gently tap them in.  
 Place panels H and I on each side of panel J as shown.  
 Then tighten screw (2) to panels H and I's upper thru holes to fix them onto panel J.

(2)

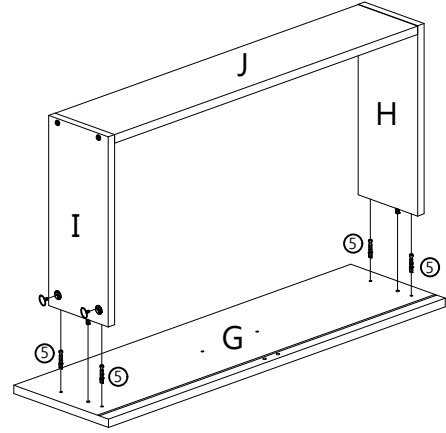

Insert, push down and tighten mini fix screw (5), to the non-thru hole as shown, 4pcs.

Inserting panels H and I's lower PVC dowels onto the center non-thru holes at panel G.

Then, tighten mini fix (5) (nuts) clockwise to lock the mini fix up for tightening panel H and I to panel G. Cover 4 mini fix caps provided by pushing the cover's stem onto the hole of mini fix nut on lower side of panel H and I.

(3)

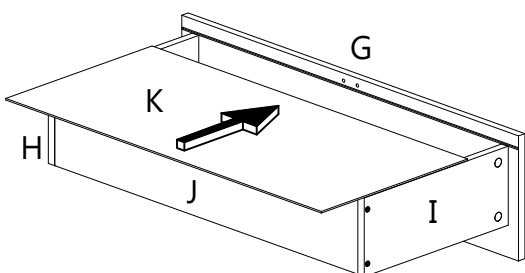

Flip drawer with bottom side up, place panel K onto panels H, I and J and insert panel K to groove of panel G.

(4)

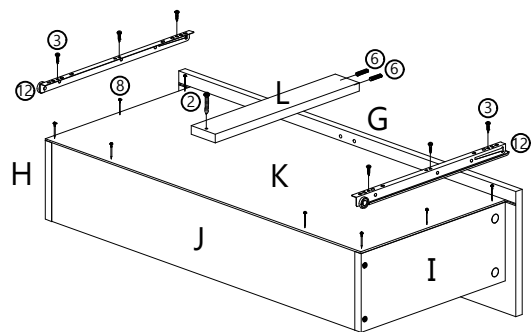

Then nail the nails (8) provided with hammer on the border of panel K as shown. The gap between 2 nails should be about 100mm.

After that, place drawer slides B (12) with the small white roller facing outward and with other end tip touching panel G onto each bottom side (angle) edge of panels H and I.

Then tighten 3 screws (3) on each drawer slide B (12) (as shown).

Insert the pvc dowels (6) to end of the panel L. Using hammer to gently tap them in.

Place and fix panel L onto panel G by inserting the dowels onto the non-thru holes at panel G.

Then tighten screw (2) to panels L's thru holes to fix them onto panels K and J.

## Assembly Of Drawers : 4 DRAWERS

(5)

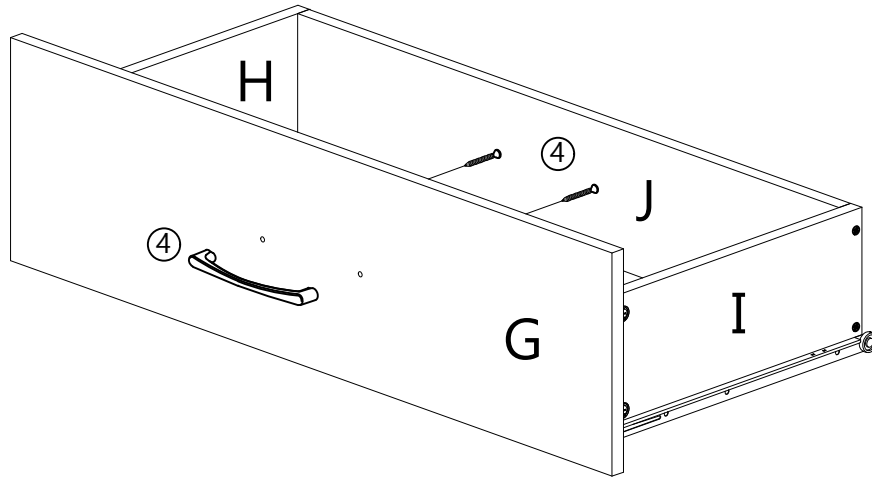

Flip drawer over with bottom side down, tighten 2 screw ④ from inner side of panel G into the handle ④'s holes.

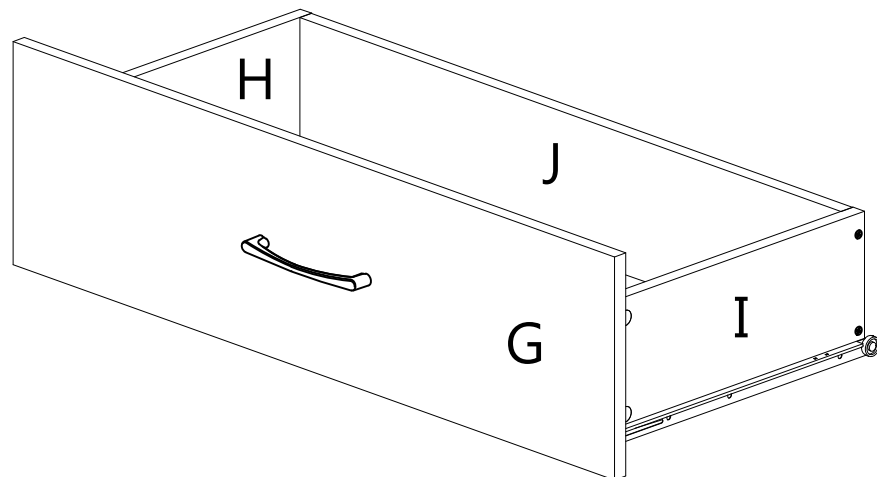

COMPLETED

# Assembly Instruction Step 1

- \* Place and fix Panel B,C onto Panel A by inserting the (Left) dowels onto the non-thru holes at Panel A.
- \* Using allen key ⑨ to tighten screws ① from the 3 thru holes of panel A , one by one.

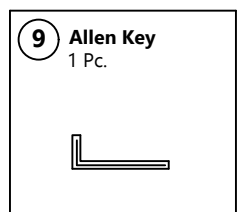
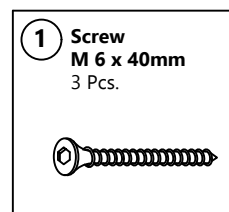
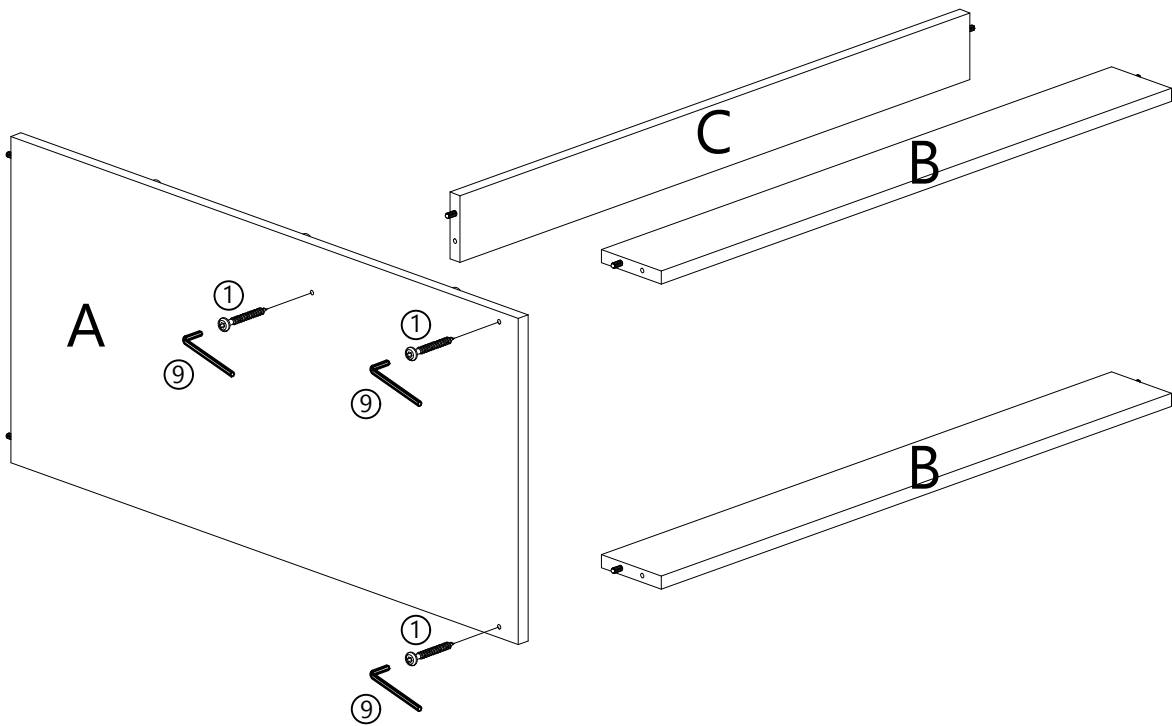

**CAUTIONS** : When insert the PVC Dowels to non-thru holes, don't push to hard. Otherwise, the side panels ( A & E ) may be damaged.

## Assembly Instruction Step 2

- \* Place and fix Panel B,C onto Panel D by pushing and slotting the (Right) dowels onto the non-thru holes at Panel D.
- \* Using allen key ⑨ to tighten screws ① from the 3 thru holes of panel D , one by one.

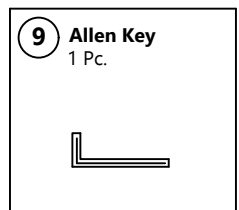
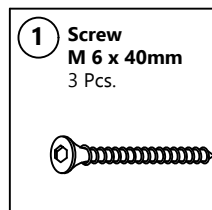
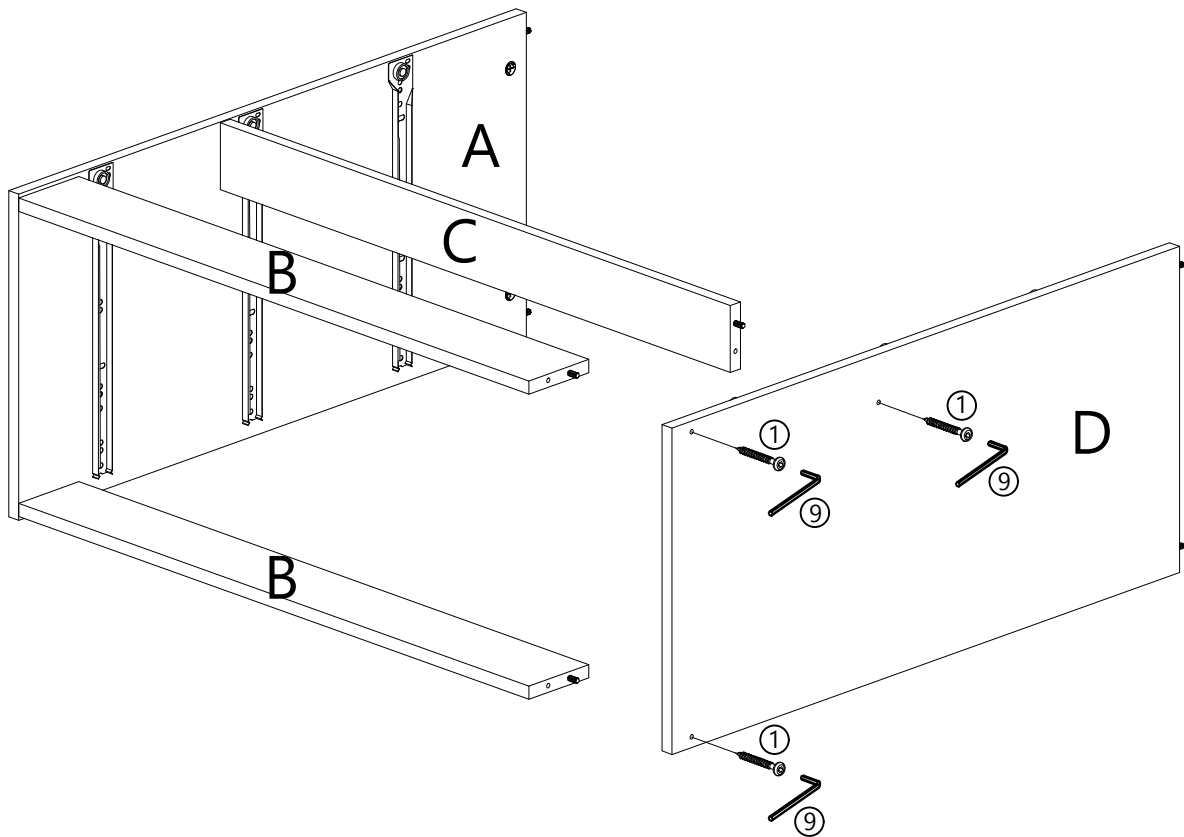

**CAUTIONS** : When insert the PVC Dowels to non-thru holes, don't push to hard. Otherwise, the side panels ( A & E ) may be damaged.

## Assembly Instruction Step 3

Place and fix panel E onto panel A and panel D, and align properly by inserting the 4 (down) mini fix screws ⑤ onto the L-thru holes at top edge of panel A and D. At the same time, inserting panel A and panel D 's upside dowel going onto panel F 's non-thru holes.

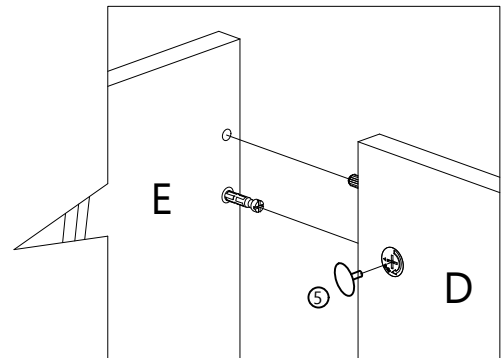
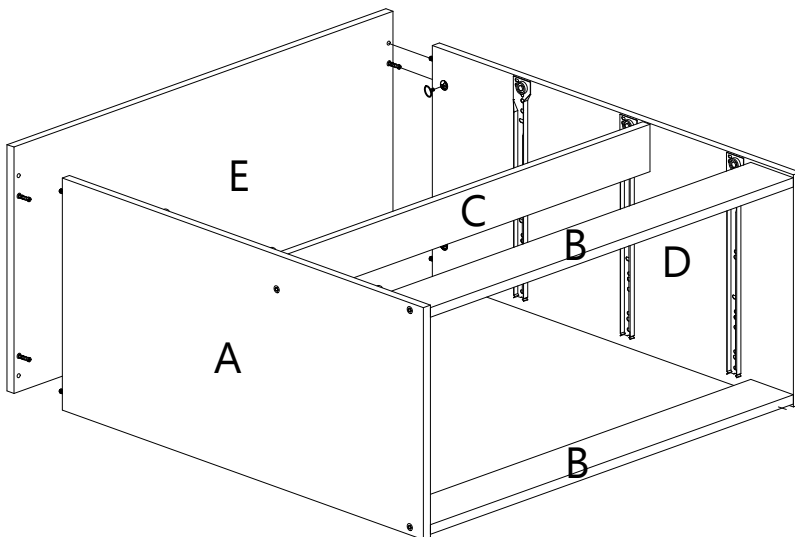
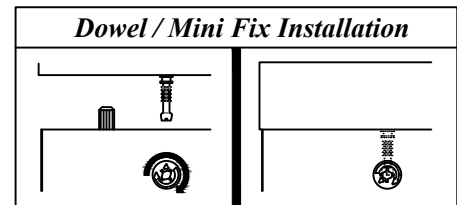

\*Then, tighten mini fix ⑤ clockwise to lock the mini fix up for tightening panel E up. Cover 4 mini fix caps provided by pushing the cover 's stem onto the hole of mini fix nut on upper side of panel A and D.

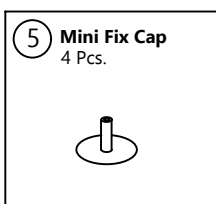

## **Assembly Instruction Step 4**

Lay the main unit at face down position, Place the 2 back panel F onto the back of the main unit, and join the 2 panel F together with H-profile by slotting one side each of panel F into the track of H-profile. Then align them properly for nailing.

Then use hammer to nail the nails one by one and at center of 4 side edges. Gap between 2 nails should be about 100mm for all.

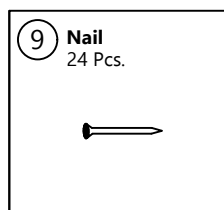
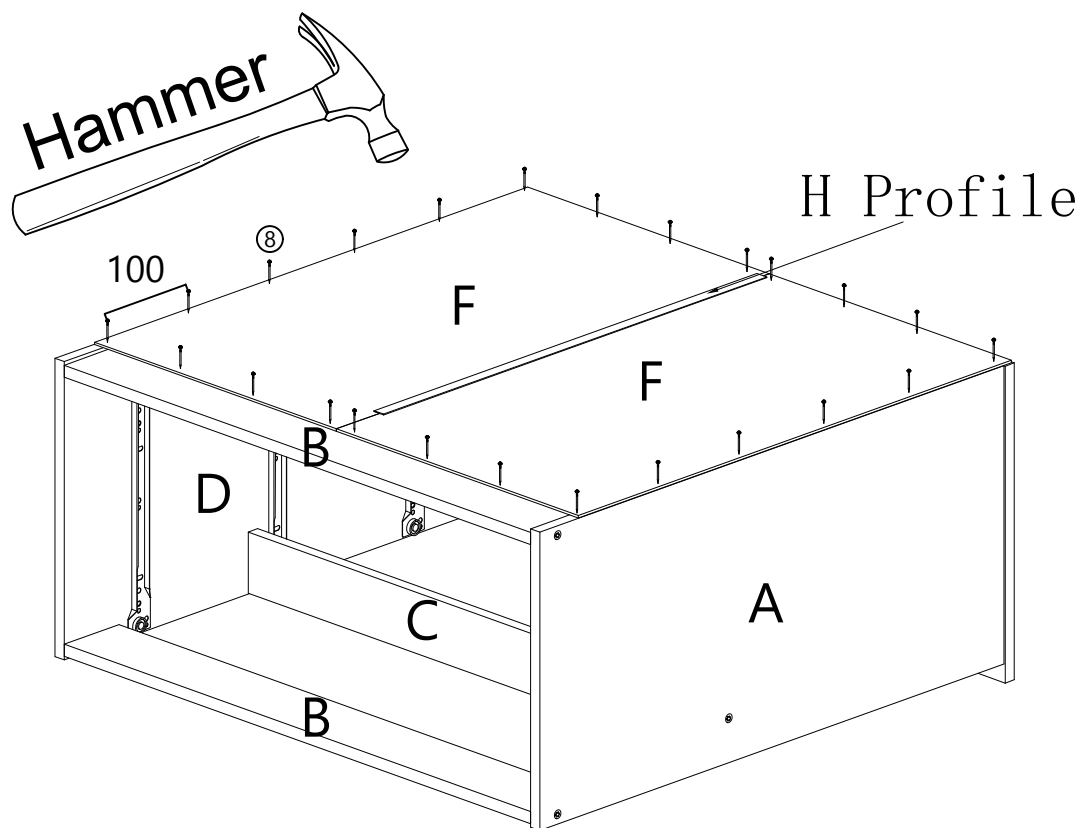

## **Assembly Instruction Step 5**

- \* Lift up the main unit carefully and let it stand up properly.
- \* Cover all the screws ① 's head with the PVC cap provided by pushing the cover's stem onto the hole of screw head one by one for all screws on panels A and D.

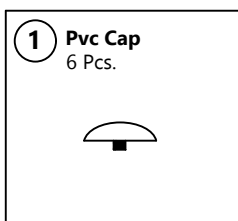
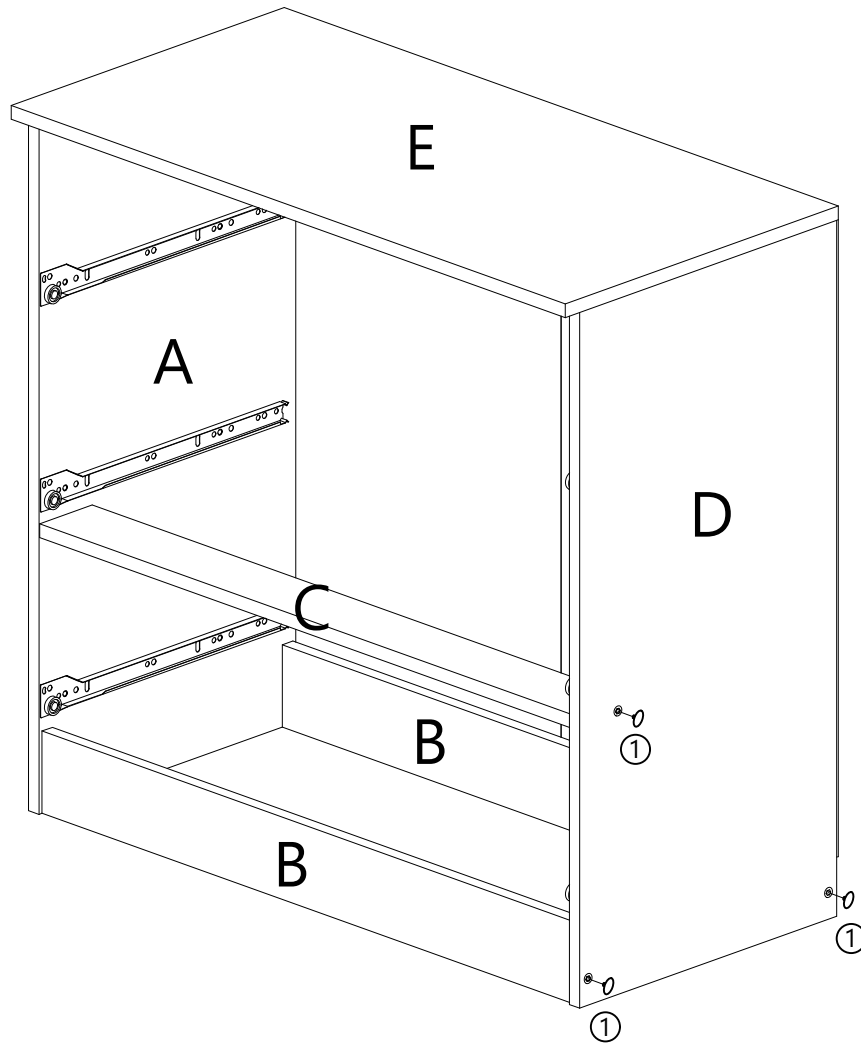

## **Assembly Instruction Step 6**

\* Take all drawers , and slide them (the white rollers at drawer slide at both side of drawers are to go into the track of the slides at each side panel.) all the way gently, one drawer by one drawer starting from bottom one

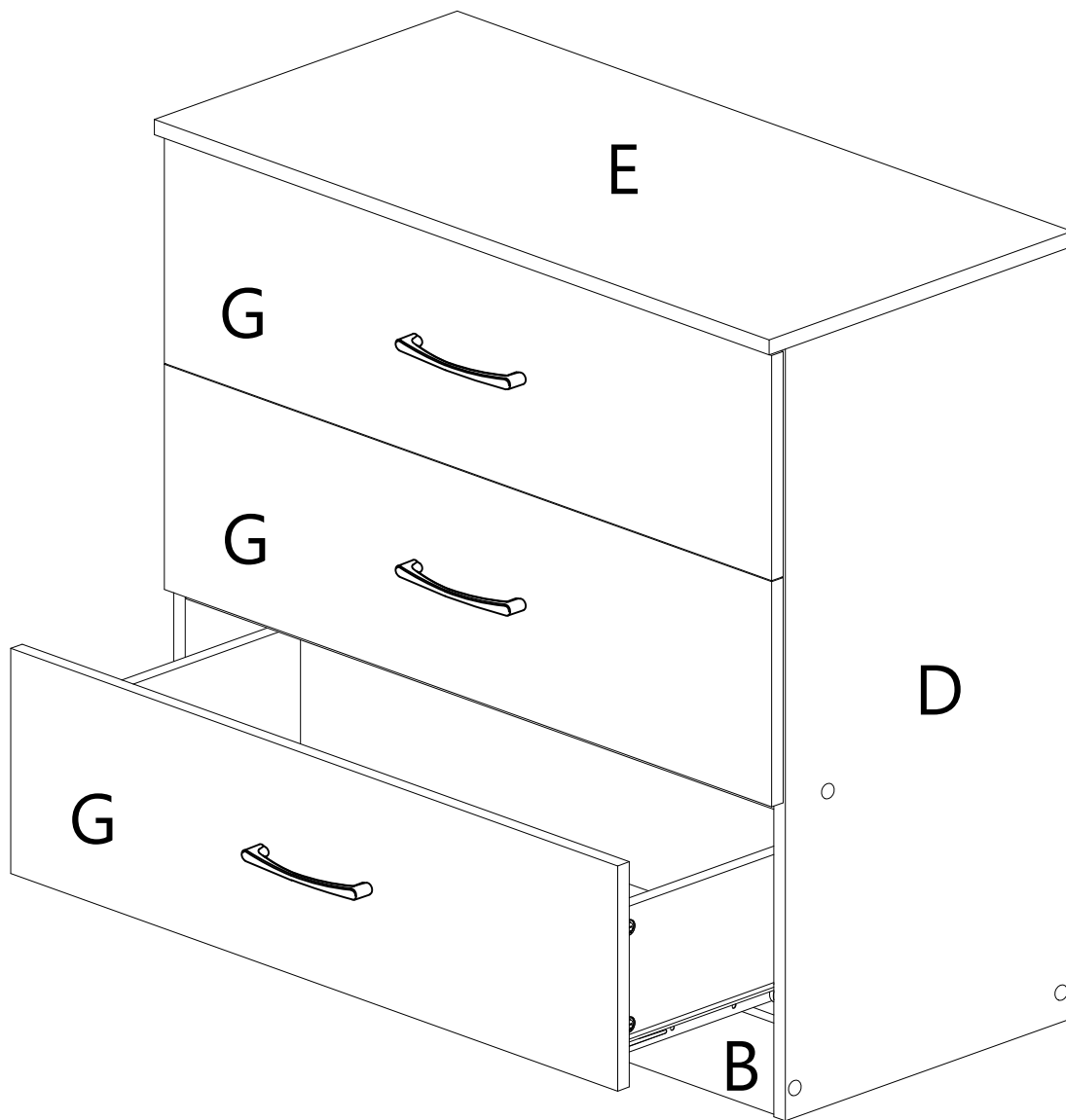

## Job Complete

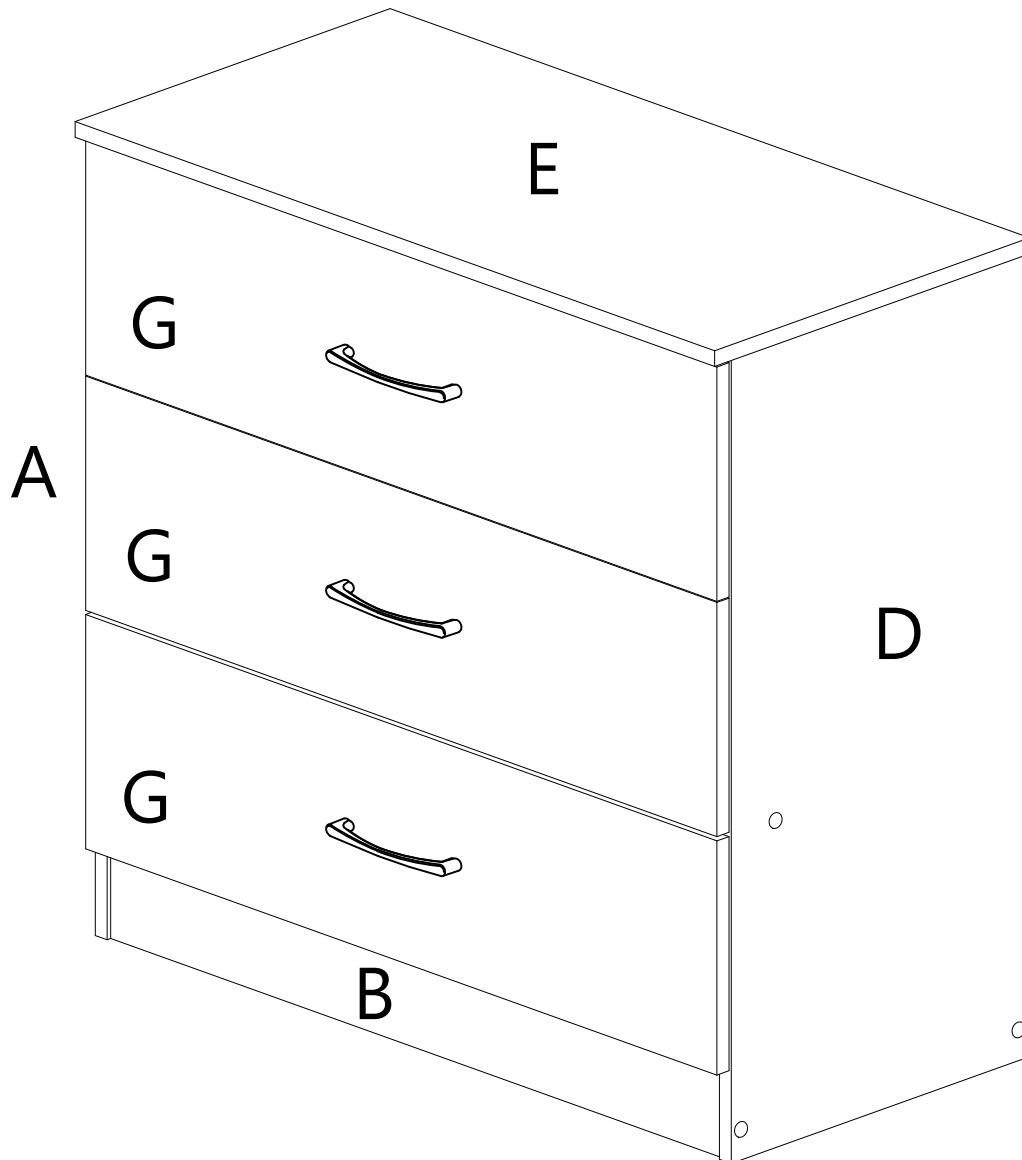

## Completion

In the interest of our environment please dispose of all packaging thoughtfully.