

Assembly Instruction



Love seat



Legs & hardware are stored on top of the Love seat, please take out legs and hardware for assembly.

Note: Do not use power tools for assembly. Power tools increase the risk of over tightening which lead to splitting or cracking the wood.

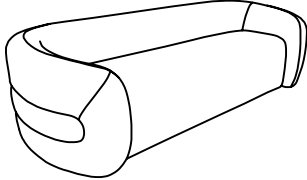
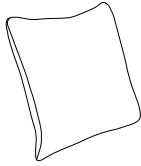
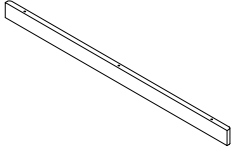
Component list

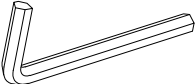
No	Drawing	Qty	Description
A		1	Love seat
B		2	Square Pillows (18"*18")
C		2	Wooden Legs (1140*75*25mm)
D		6	Bolt (1/4"*70mm)
E		6	Flat washer (1/4"*Ø16*1.5mm)
F		1	Allen key (M4*59mm)

THE PARTS ARE LOCATED INSIDE THE BOX AS BELOW:

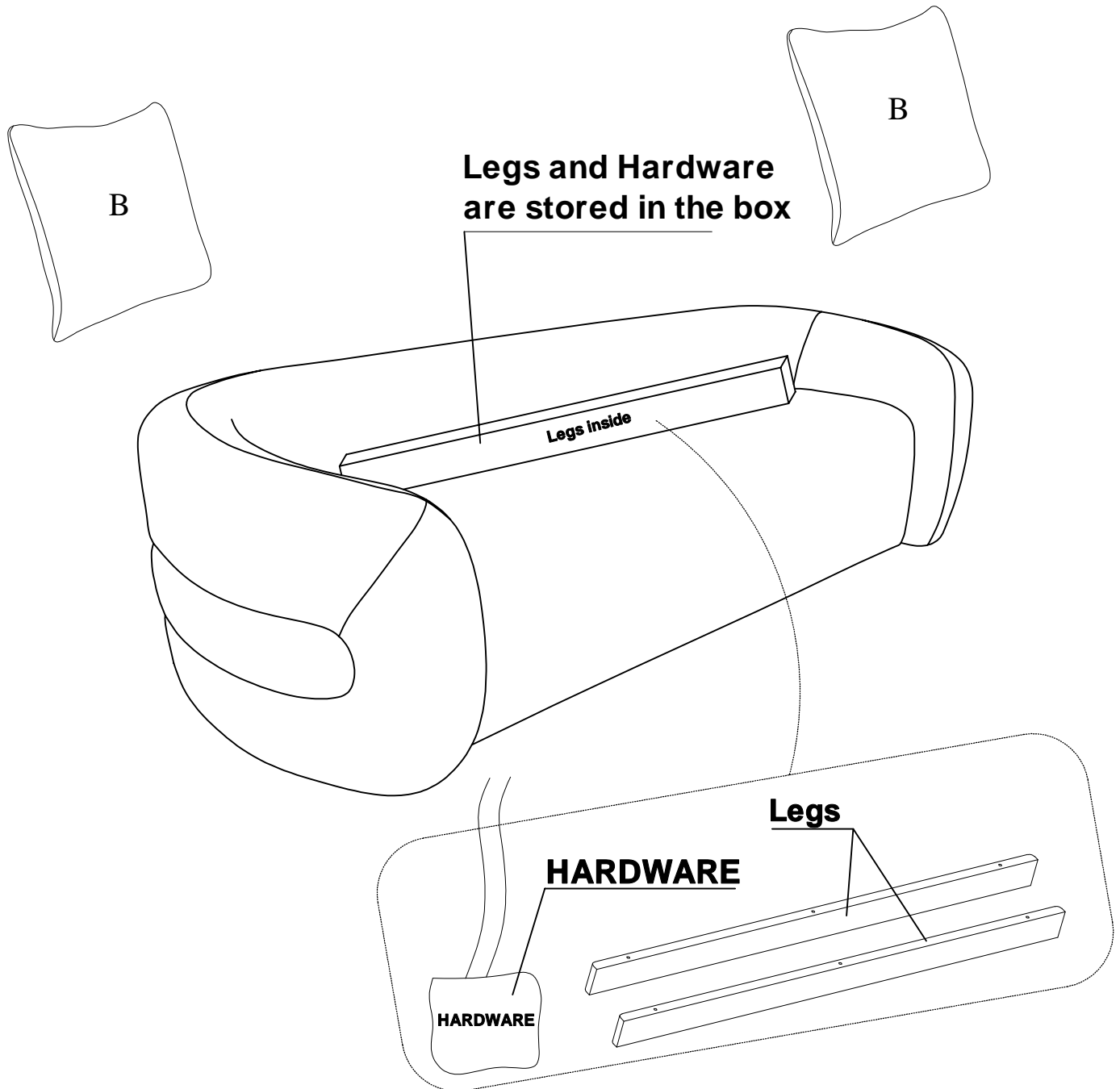

Step #1

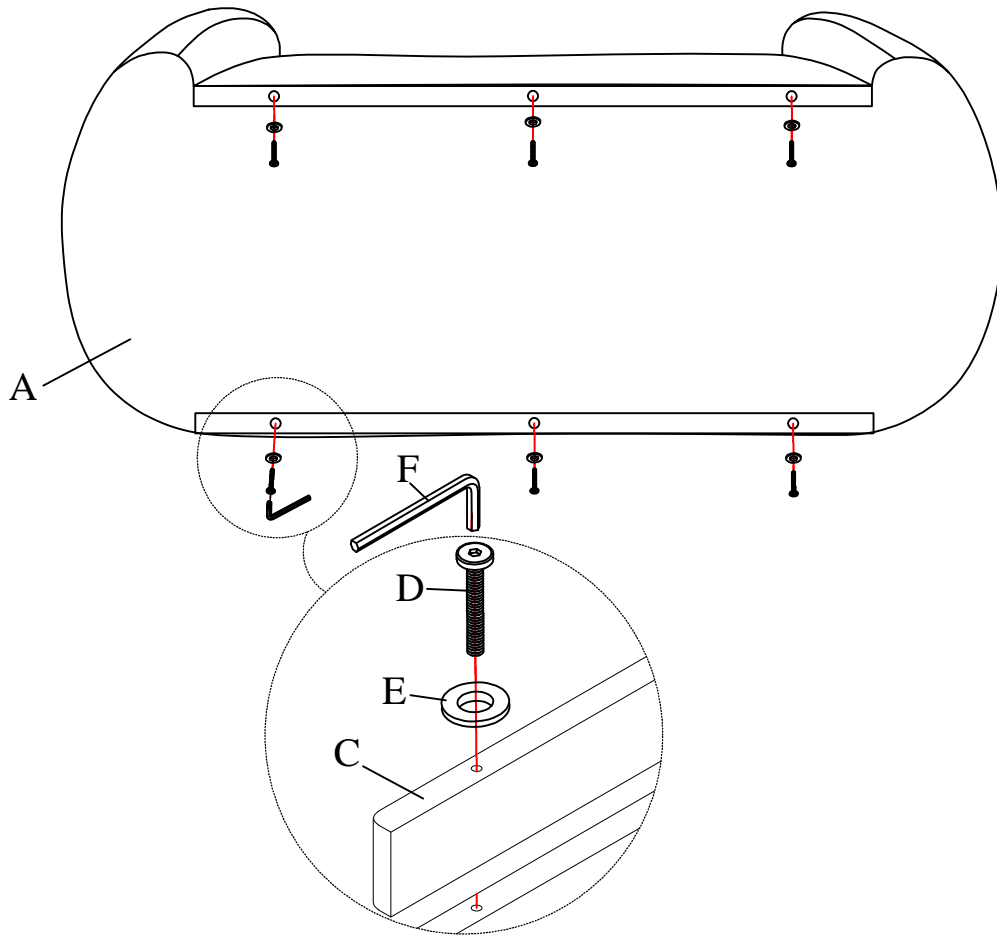

Step #2

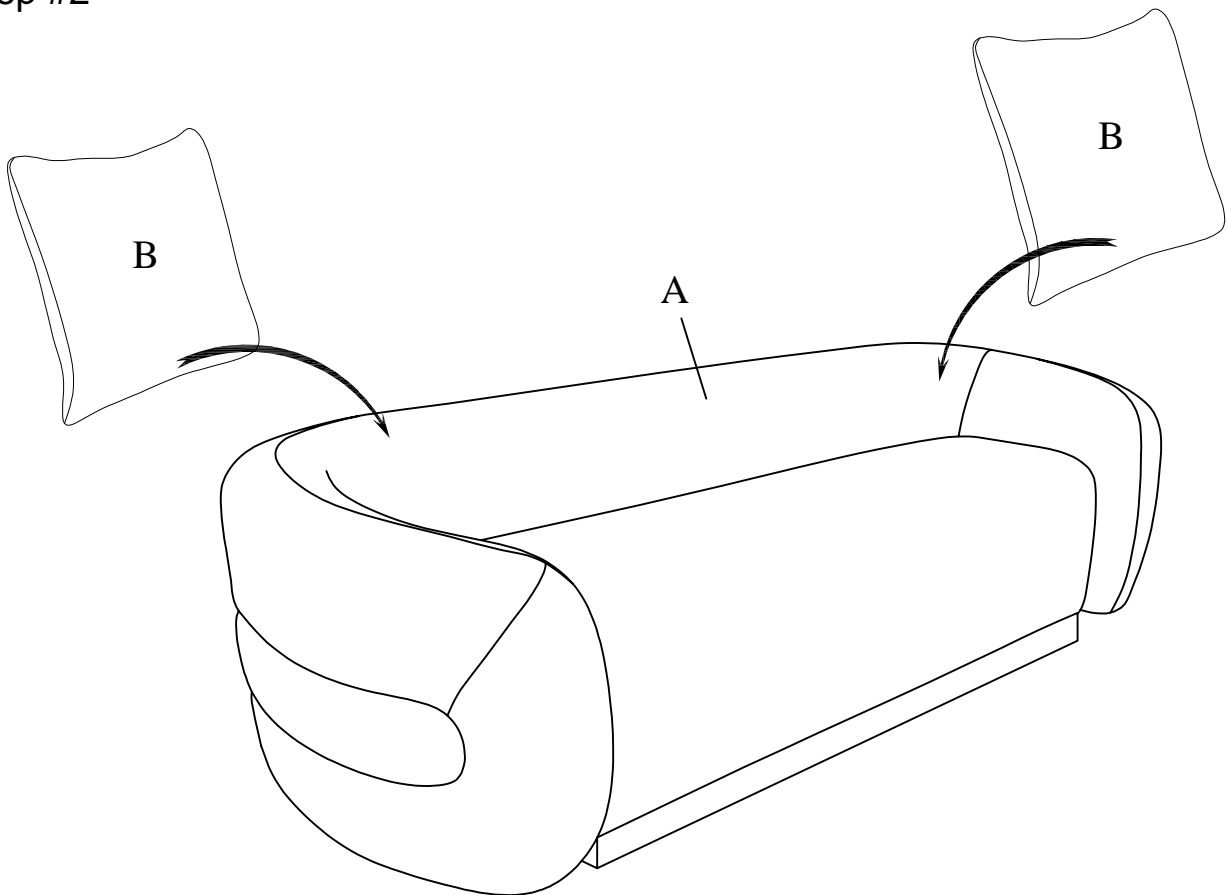

Step #3

Assembly completed.

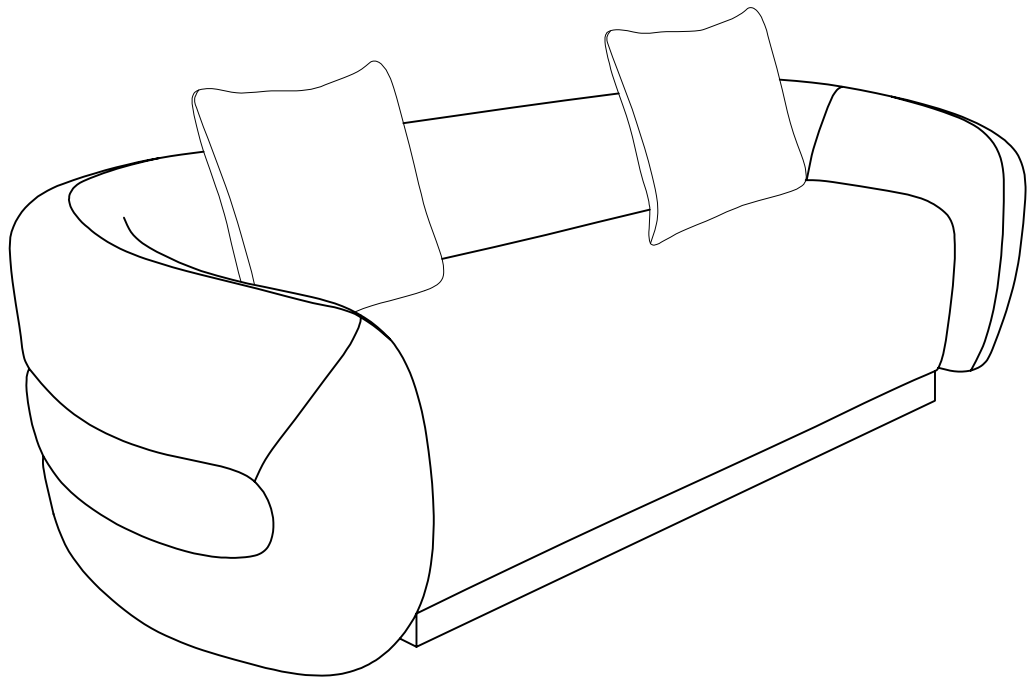

Care Instruction for Sherpa Furniture:

In order to maintain the original appearance of your sherpa, please follow below simple care procedures:

- Avoid exposing furniture directly to sunlight or heating and air conditioning outlets. Sunlight and/or exposure to heating and air conditioning outlets will fade/damage sherpa. Do not place your upholstered furniture too close to windows, radiators, or vents, and be sure to use windows, radiators, or vents.
- Vacuum or wipe with a soft cloth to remove dust.
- Hardware may loosen over time. Periodically check to make sure all connections are tight. Re-tighten if necessary.



For items use on wooden floor, hard surfaces or carpets, it is recommended to Install protective pads under all legs and supports to avoid/prevent from damages/scratches and discoloration.

Assembly Instruction



Sofa



Legs & hardware are stored on top of the Sofa, please take out legs and hardware for assembly.

Note: Do not use power tools for assembly. Power tools increase the risk of over tightening which lead to splitting or cracking the wood.

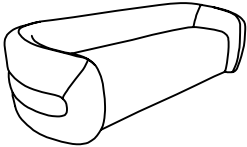
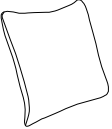
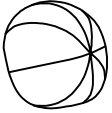
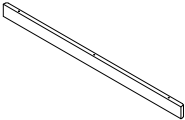
Component list

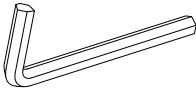
No	Drawing	Qty	Description
A		1	Sofa
B		2	Square Pillows (18"*18")
C		2	Ball Pillows (12"*12")
D		2	Wooden Legs (1710*75*25mm)
E		6	Bolt (1/4"*70mm)
F		6	Flat washer (1/4"*Ø16*1.5mm)
G		1	Allen key (M4*59mm)

THE PARTS ARE LOCATED INSIDE THE BOX AS BELOW:

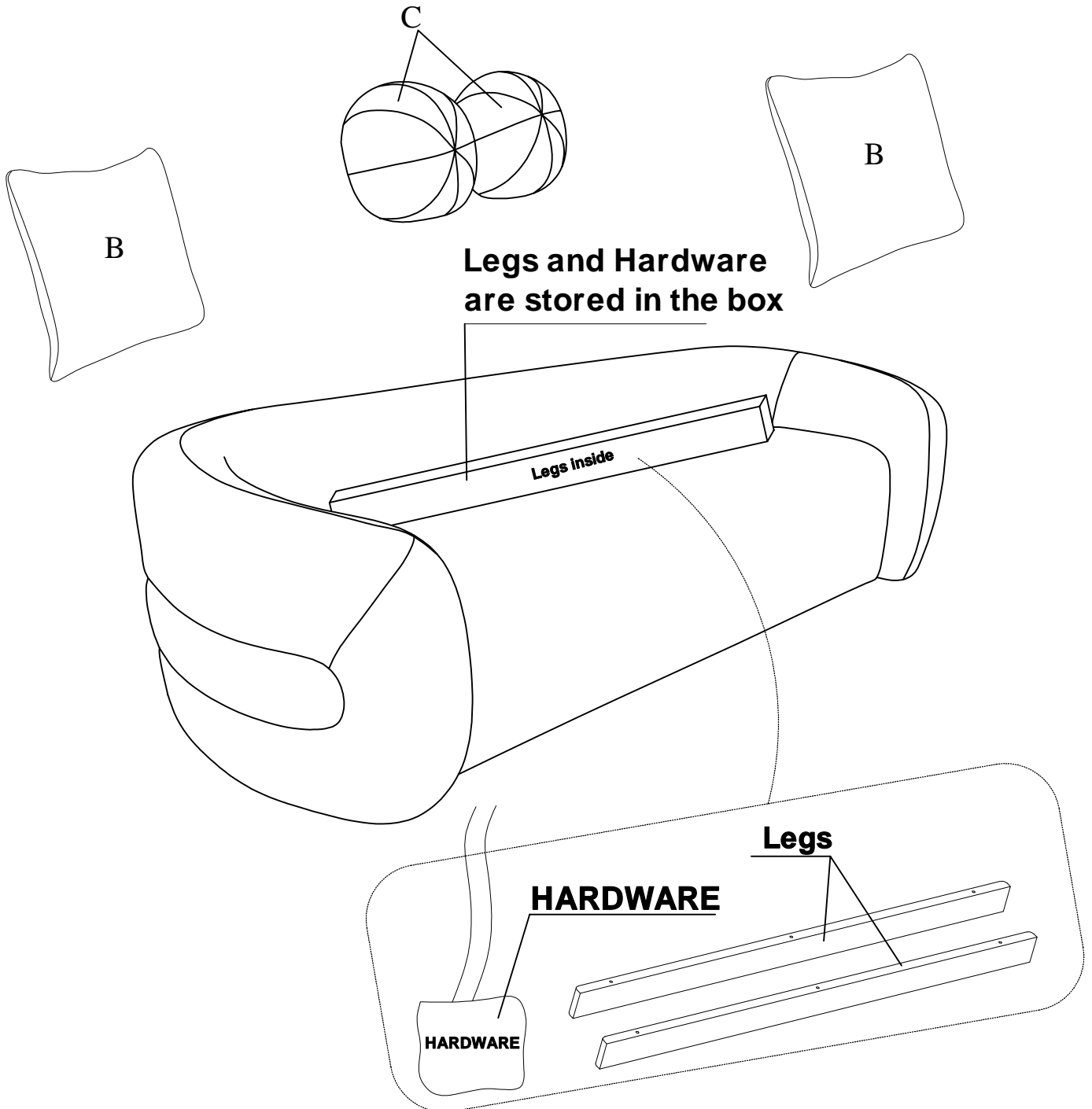

Step #1

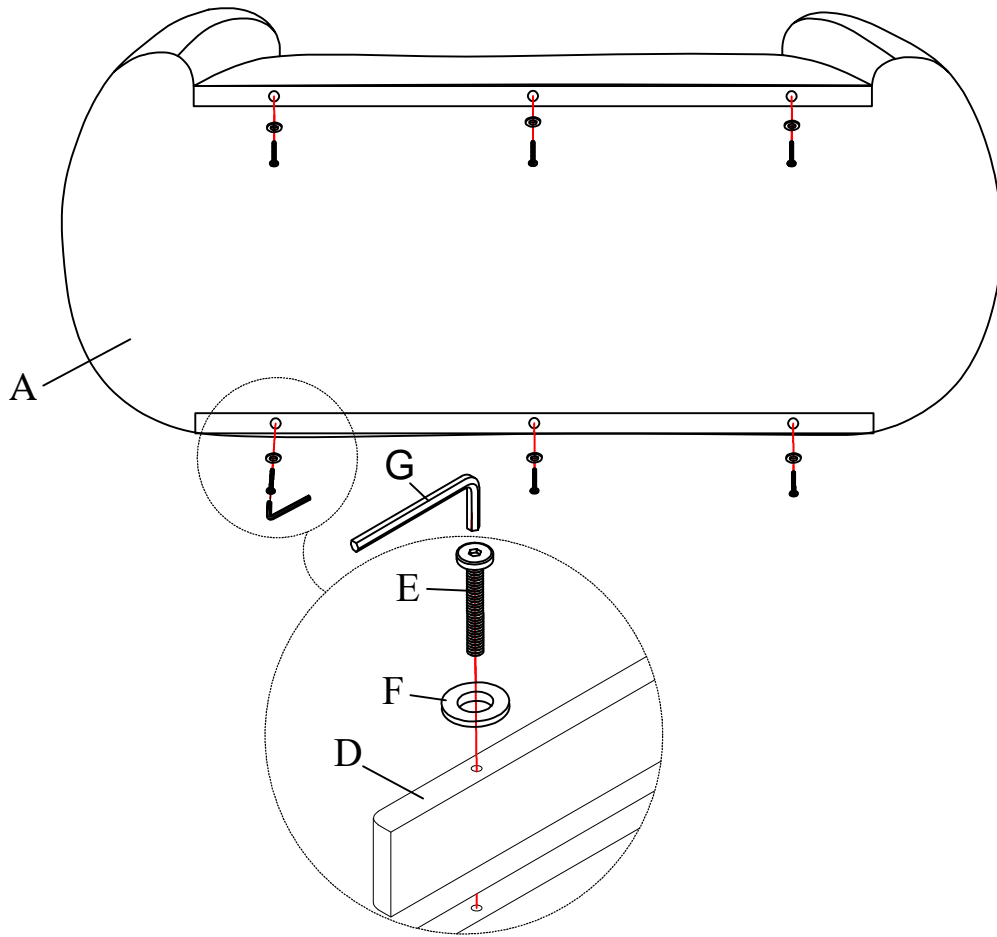

Step #2

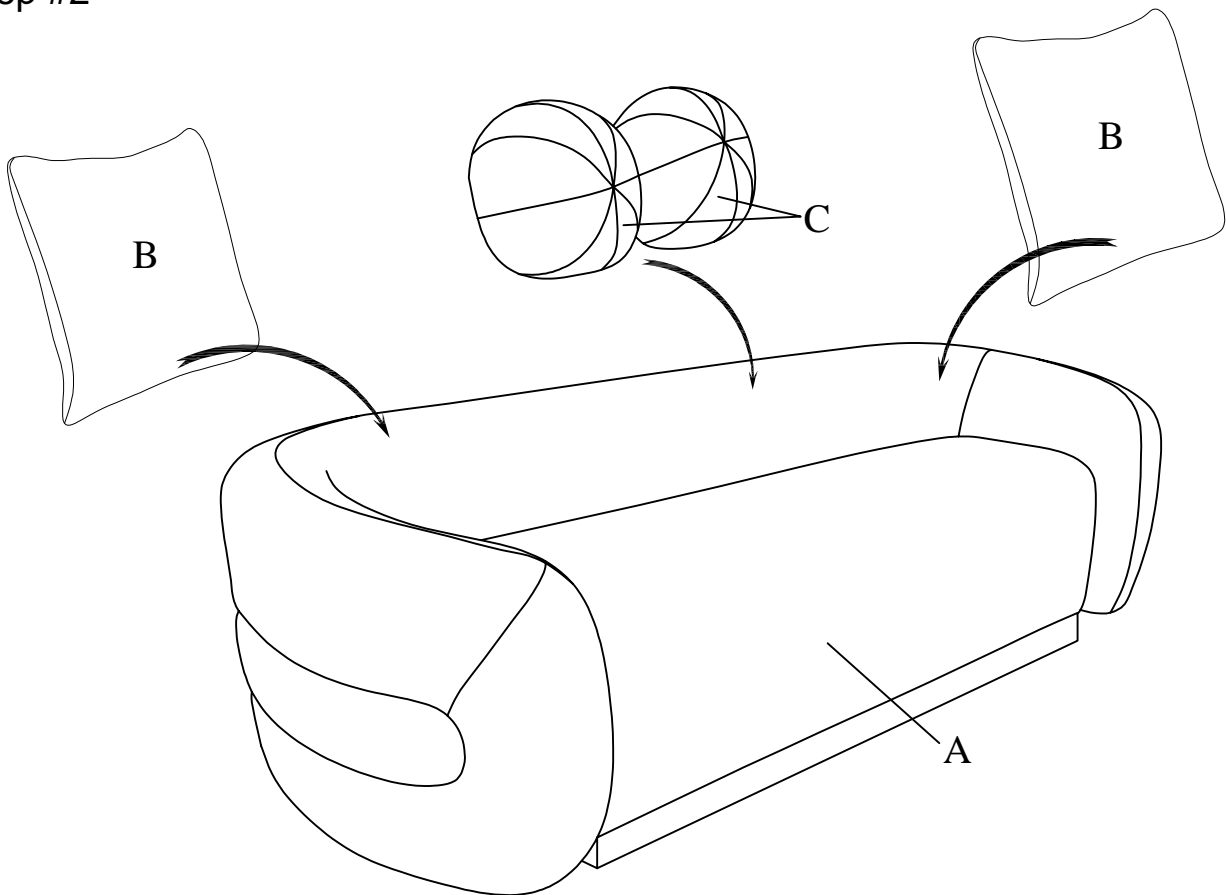

Step #3

Assembly completed.

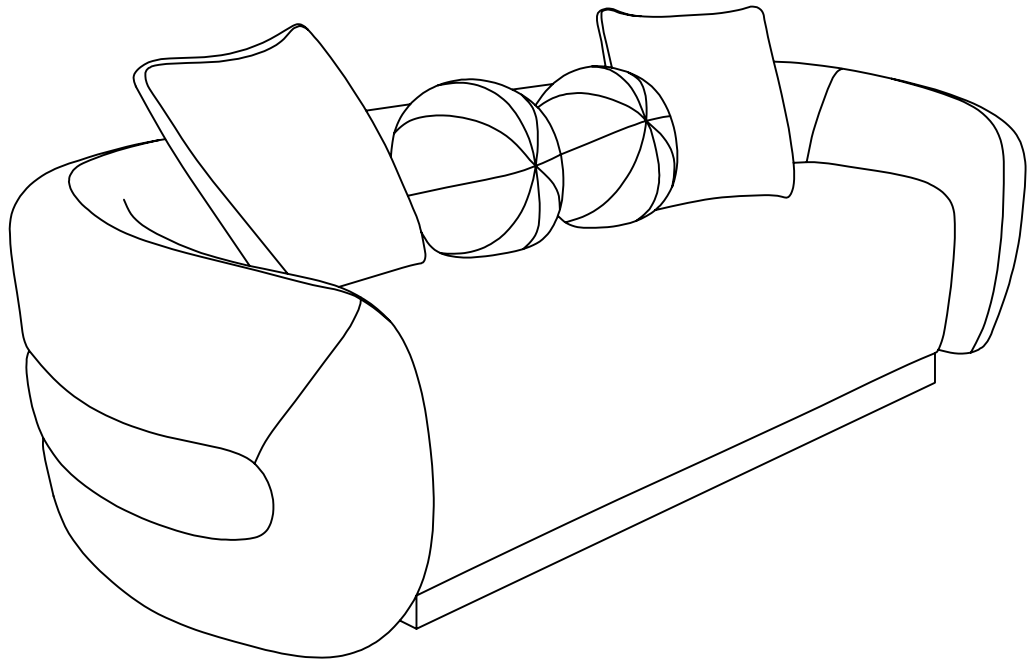

Care Instruction for Sherpa Furniture:

In order to maintain the original appearance of your sherpa, please follow below simple care procedures:

- Avoid exposing furniture directly to sunlight or heating and air conditioning outlets. Sunlight and/or exposure to heating and air conditioning outlets will fade/damage sherpa. Do not place your upholstered furniture too close to windows, radiators, or vents, and be sure to use windows, radiators, or vents.
- Vacuum or wipe with a soft cloth to remove dust.
- Hardware may loosen over time. Periodically check to make sure all connections are tight. Re-tighten if necessary.



For items use on wooden floor, hard surfaces or carpets, it is recommended to Install protective pads under all legs and supports to avoid/prevent from damages/scratches and discoloration.