

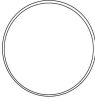





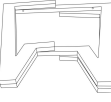

# Assembly Instructions

Laying out all the parts and hardware and identifying each part as shown may help you as you assemble the table.

ITEM	PART	DESC.	QTY	ITEM	PART	DESC.	QTY
A		Table top	1	D		Flat washer	4
B		Wood base	1	E		Bolts (6×45mm)	4
C		Bottom shlef	1	F		Allen wrench	1

## STEP ONE

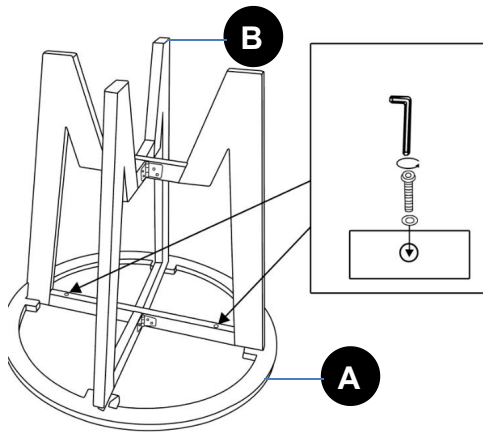

## STEP TWO

承重: 25L

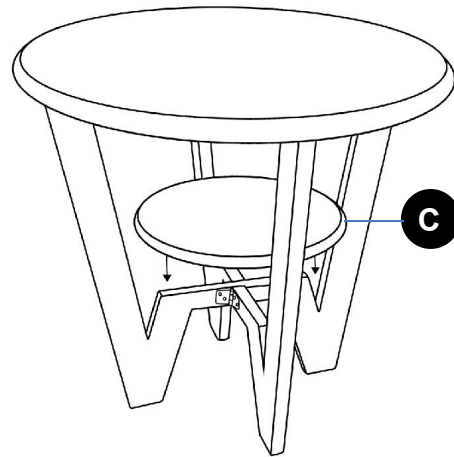

Put the table top upside down. Open wood base, attach wood base to table top by bolts and flat washers as shown above.

Insert bottom shelf as shown above.

## STEP THREE

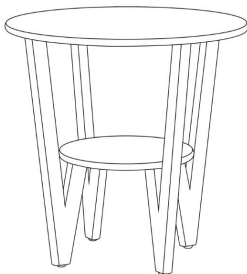

Finished product. Please make sure the bolts are fully tightened before using this table .



### WARNING

- Do not let any sharp objects touch or rub the surface of the product.
- When assembling ,do not let children play around the working area.
- Please confirm all parts are correct before starting the assembly process.
- Use only the Allen wrench provided.DO NOT USE POWER TOOLS.