

Missing parts request:

To obtain replacement part(s), fill in quantity in the "missing" box under the "Parts List" section. Complete contact and shipping information in address box accurately and clearly. Please allow 7-14 days for delivery.

Demande de pièces manquantes:

Pour obtenir une (des) pièce(s) de remplacement, remplissez la case « manquant » sous la section « Liste des pièces ». Fournissez vos coordonnées et informations d'expédition dans la case Adresse de manière claire et précise. La livraison aura lieu dans un délai de 7 à 14 jours.

Petición de partes perdidas:

Para obtener parte(s) de reemplazo, llené en número la cantidad en el cuadro de "missing" debajo de "Lista de partes" sección. Llené su información de contacto y envío en el cuadro de dirección clara y correcta. Por favor permita 7-14 días para envío.

Name - Nom - Nombre

Address - Adresse - Dirección

City/State/Zip - Ville/Province/Code postal - Ciudad/Estado/Zona Postal

Phone - Téléphone - Teléfono

Email

Reason of replacement/Raison de remplacement/Razón del reemplazo

- Missing/Manquant/Ausente
- Damaged/Endommagé/Dañado
- Not Fit/Ne rentre pas/No ajusta
- Other, explain/Autre, expliquer/Otro, explicar

Parts List - Liste des pieces - Lista de partes

A1	Left Vertical Post (upper) Montant vertical gauche (supérieur) Poste vertical izquierdo (superior)		
Quantity Quantité Cantidad	1	Replace Remplacer Reemplazar	

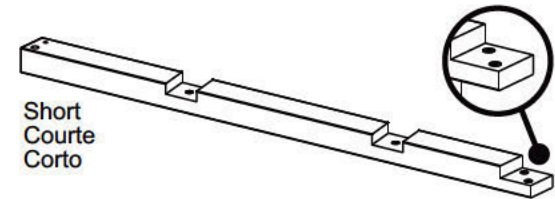

Short
Courte
Corto

A2	Left Vertical Post (lower) Montant vertical gauche (inférieur) Poste vertical izquierdo (inferior)		
Quantity Quantité Cantidad	1	Replace Remplacer Reemplazar	

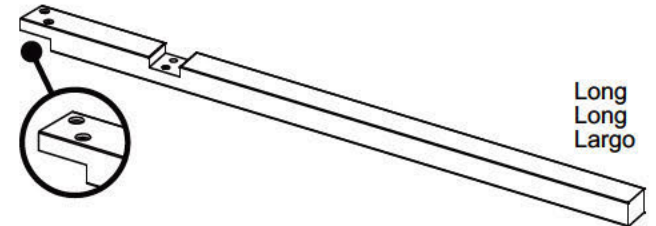

Long
Long
Largo

B1	Right Vertical Post (upper) Montant vertical droit (supérieur) Poste vertical derecho (superior)		
Quantity Quantité Cantidad	1	Replace Remplacer Reemplazar	

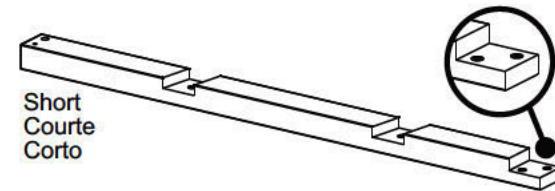

Short
Courte
Corto

B2	Right Vertical Post (lower) Montant vertical droit (inférieur) Poste vertical derecho (inferior)		
Quantity Quantité Cantidad	1	Replace Remplacer Reemplazar	

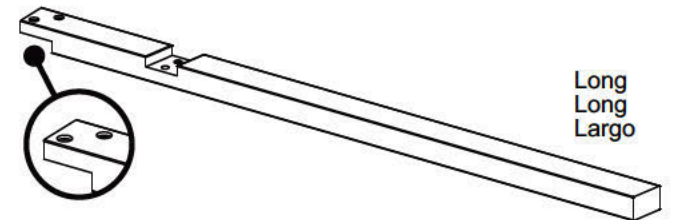

Long
Long
Largo

Parts List - Liste des pièces - Lista de partes

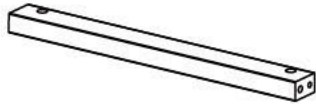

C	Cross Bar Traverse Travesaño			
Quantity Quantité Cantidad	1	Replace Remplacer Reemplazar		

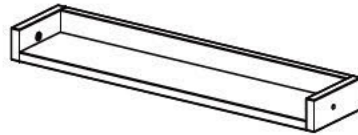

D	Shelf #1 (small) Étagère #1 (petite) Entrepaño #1 (pequeño)			
Quantity Quantité Cantidad	1	Replace Remplacer Reemplazar		

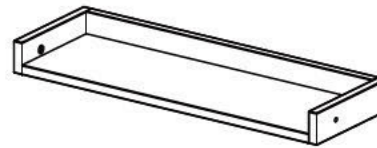

E	Shelf #2 (large) Étagère #2 (grand) Entrepaño #2 (grande)			
Quantity Quantité Cantidad	1	Replace Remplacer Reemplazar		

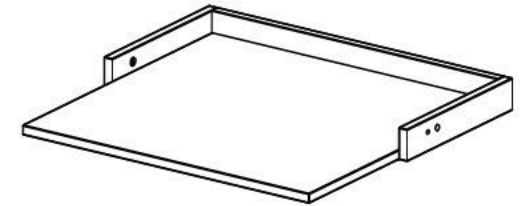

F	Desktop Dessus de bureau Tapa del escritorio			
Quantity Quantité Cantidad	1	Replace Remplacer Reemplazar		



G	Bolt Boulon Tornillo			
Quantity Quantité Cantidad	10	Replace Remplacer Reemplazar		



H	Wood Dowel Goujon en bois Clavija de madera			
Quantity Quantité Cantidad	4	Replace Remplacer Reemplazar		



I	Cam Lock Screw* Vis à blocage rapide* Tornillo para cam-lock*			
Quantity Quantité Cantidad	2	Replace Remplacer Reemplazar		



J	Cam Lock* serrure batteuse* cam-lock*			
Quantity Quantité Cantidad	2	Replace Remplacer Reemplazar		



	Hex Wrench Clé hexagonale Llave hexagonal			
Quantity Quantité Cantidad	1	Replace Remplacer Reemplazar		

* Screw Driver is required and not included in the package. * Un tournevis est nécessaire mais n'est pas inclus avec cet ensemble. * Se requiere desarmador de cruz y no viene incluido.

Care instructions: To clean, wipe with damp cloth and dry thoroughly. Use mild soap if necessary. Avoid use of commercial waxes or polishes or abrasive cleaning materials.

Instructions d'entretien: Pour nettoyer, essuyez avec un linge humide et séchez à fond. Utilisez un savon doux au besoin. Évitez d'utiliser des cires ou produits à polir de type commercial ou des matériaux de nettoyage abrasifs.

Instrucciones para el cuidado: Para limpiar, frótelo con algo húmedo y séquelo bien. Use un jabón suave si es necesario. Evite el uso de ceras o pulidores comerciales o materiales abrasivos.

Assembly Instructions - Instructions d'assemblage - Instrucciones de ensamblaje

1



ASSEMBLY
ASSEMBLAGE
ENSAMBLAJE
TWO PERSONS
DEUX PERSONNES
DOS PERSONAS

REF. 1



J

Note:
Insert cam-lock
in open position,
rotate to open
position with screw
driver if necessary.

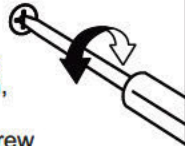

Remarque:
Insérez la serrure
batteuse en
position ouverte,
tourner en
position ouverte
avec le tournevis
si nécessaire.

Nota:
Inserta el "cam-lock"
en posición abierta,
volteé en
posición abierta
con
desarmador si es necesario.

Turn to lock
with screw-driver.
Warning: Do not
over tighten cam lock.

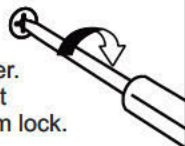

Tourner pour
verrouiller
avec tournevis.
Avertissement: Ne pas trop
serrer serrure batteuse.

Volteé para cerrar
con desarmador.
Advertencia: No
sobre-aprietecam-lock.

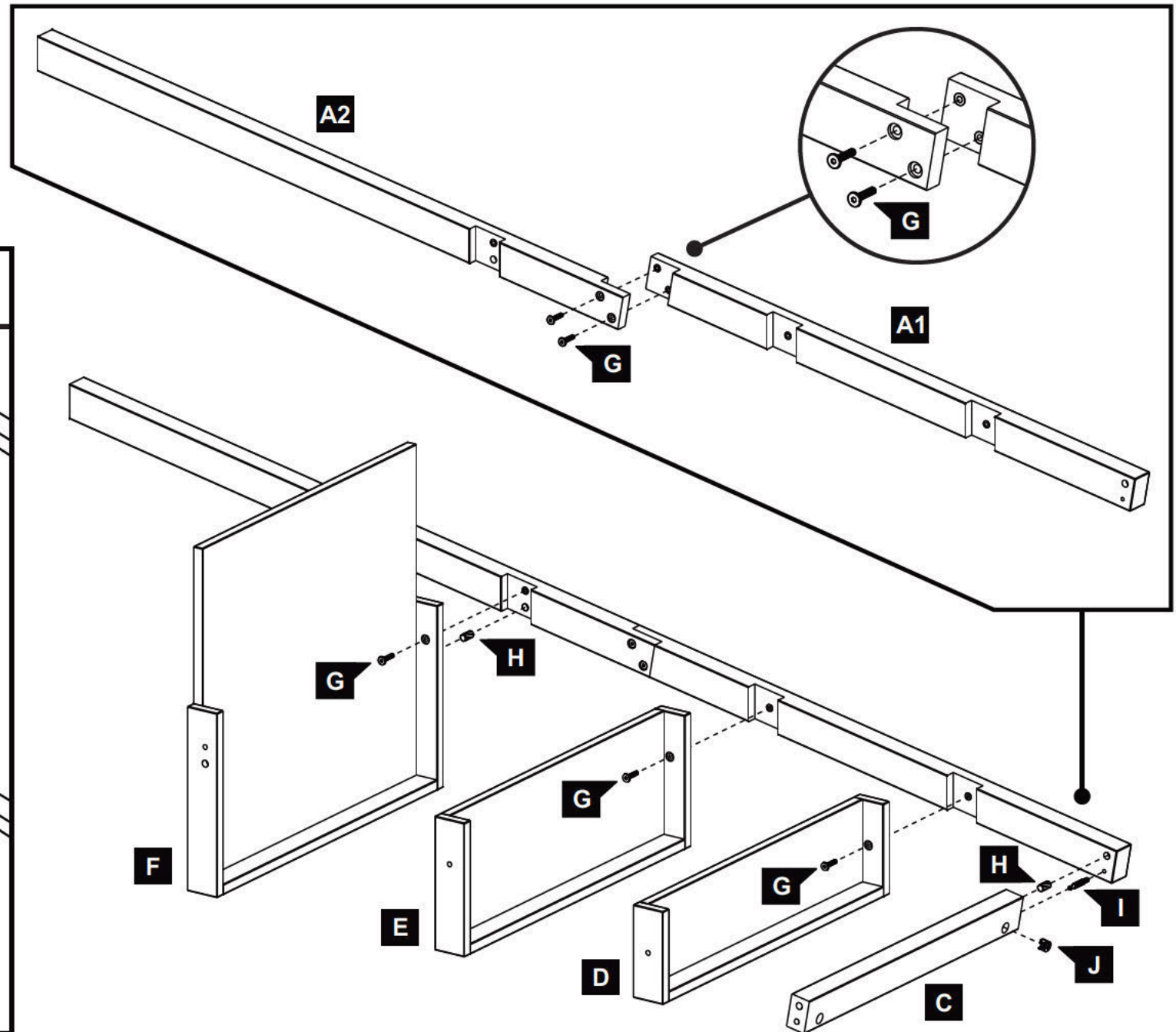

Assembly Instructions - Instructions d'assemblage - Instrucciones de ensamblaje

2



ASSEMBLY
ASSEMBLAGE
ENSAMBLAJE
TWO PERSONS
DEUX PERSONNES
DOS PERSONAS

REF. 1

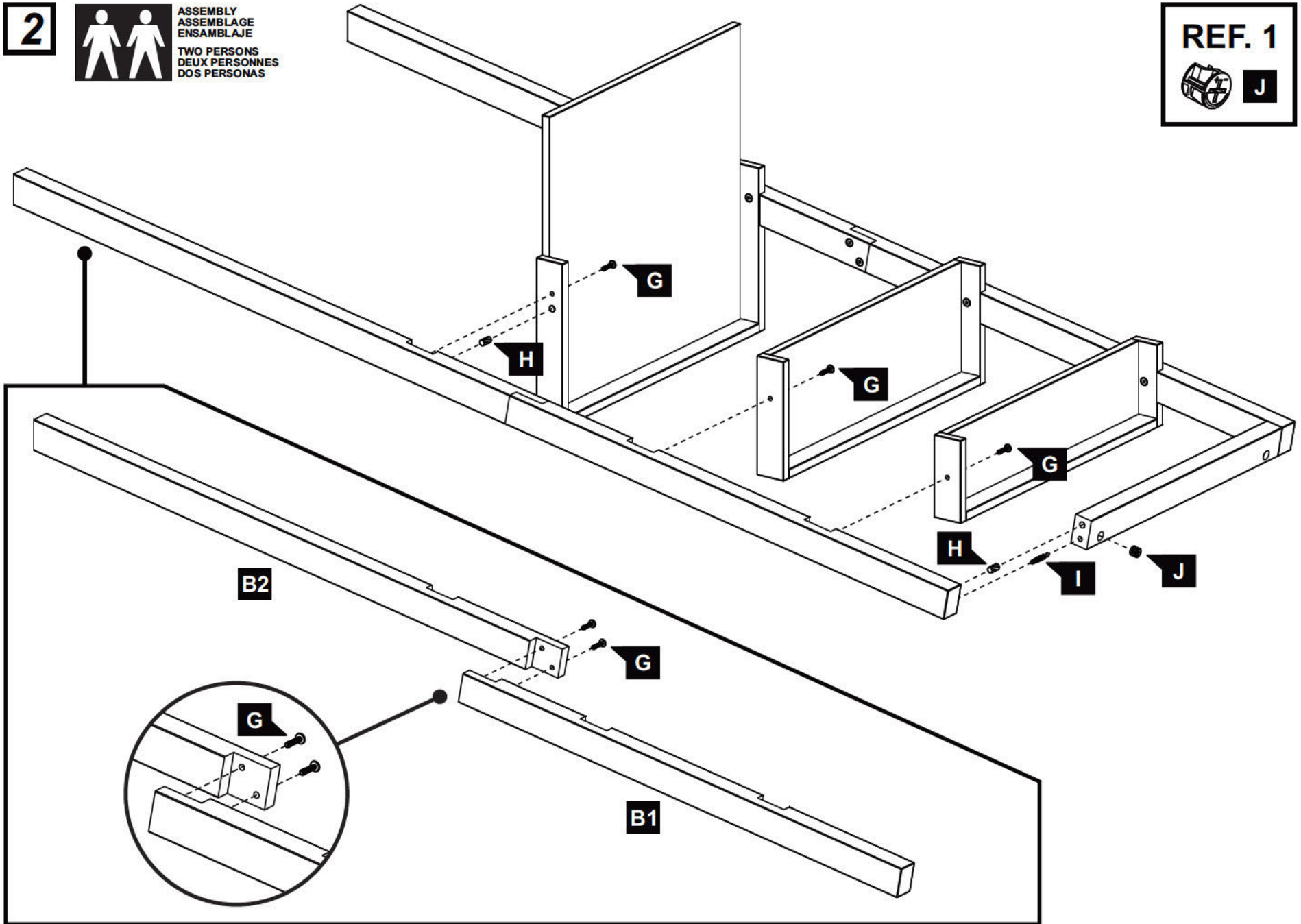

B2

B1

G

G

G

G

G

H

I

J