

WICHTIG - FÜR SPÄTERE VERWENDUNG
AUFBEWAHREN - SORGFÄLTIG LESEN

AVIS - Ces instructions doivent être sauvegardées
Pour utilisation future - Les instructions doivent
être suivies

IMPORTANTE, conservar estas instrucciones
para futuro uso. Siga estas instrucciones atentamente

VIGTIGT - Samvejledningen skal opbevares
i arkiv til senere brug - Skal gennemlæses nøje

NOTICE - These instructions must be saved
for future use - Instructions must be followed

TEILCHECKLISTE LISTE
DE CONTROLE
LISTADO DE CONTROL
TJEKLISTE
CHECK LIST

Réf./No.	Qty./Stck./Quantité	Size / Maß / Dimension (mm)	Qty./Stck./Quantité	✓
1	1	Φ1200x18		
2	1	554x554x18		
3	1	Φ534x18		
4	1	696x345x16		
5	2	696x345x16		
6	2	345x150x16		
7	2	230x56.5x16		
8	2	330x150x150		
9	1	Φ506x706		





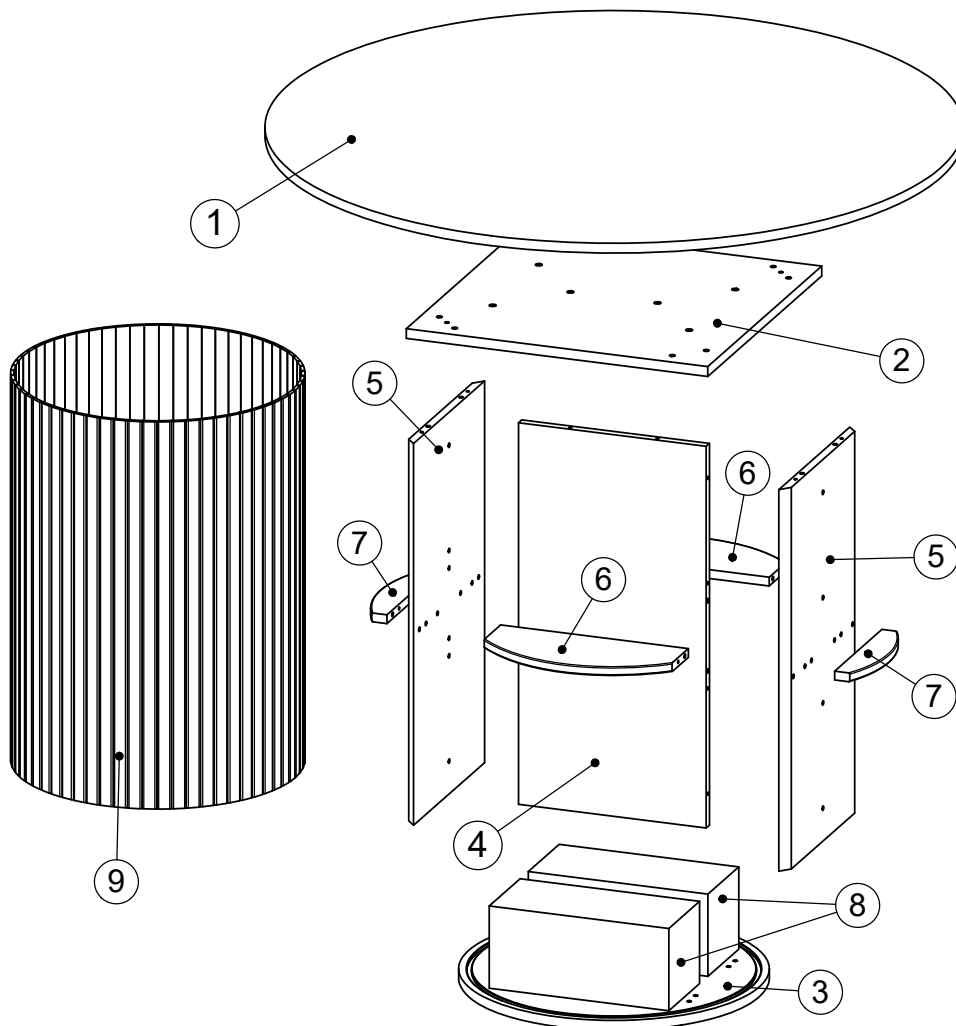

Réf./No.	Qty./Stck./Quantité	Size / Maß / Dimension (mm)	Qty./Stck./Quantité	✓
1	1	Φ1200x18		
2	1	554x554x18		
3	1	Φ534x18		
4	1	696x345x16		
5	2	696x345x16		
6	2	345x150x16		
7	2	230x56.5x16		
8	2	330x150x150		
9	1	Φ506x706		

Réf./No.	Qty./Stck./Quantité	Size / Maß / Dimension (mm)	Qty./Stck./Quantité	✓
1	1	Φ1200x18		
2	1	554x554x18		
3	1	Φ534x18		
4	1	696x345x16		
5	2	696x345x16		
6	2	345x150x16		
7	2	230x56.5x16		
8	2	330x150x150		
9	1	Φ506x706		

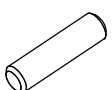
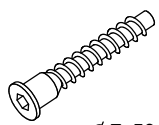

TEILCHECKLISTE - LISTE DE CONTROLE - LISTADO DE CONTROL- TJEKLISTE - CHECK LIST

Réf./No.		Qty./Stck./Quantité	✓
A		20	
E		28	
F		1	
P		8	
Q		8	
R		8	
S		2	

<p>20 - A</p>  <p>∅8x30mm</p>	<p>32 - E</p>  <p>∅7x50mm</p>	<p>1 - F</p>  <p>4mm</p>	<p>8 - P</p>  <p>M6x30mm</p>	<p>8 - Q</p>  <p>∅6 x ∅18mm</p>	<p>8 - R</p>  <p>∅6mm</p>
<p>2 - S</p>  <p>∅8x25mm</p>					

Geehrter Kunde.
Hier haben Sie die Möglichkeit die mitgelieferten
Schrauben nachzumessen.

Cher Client.
La règle ci jointe vous permet de mesurer la visserie.

Estimado cliente.
aquí podrá medir la tornillería adjunta.

Kære kunde.
Her har De muligheden for at måle medsendte beslag.

Dear Customer.
Below you have the opportunity to measure the
Enclosed Hardware.

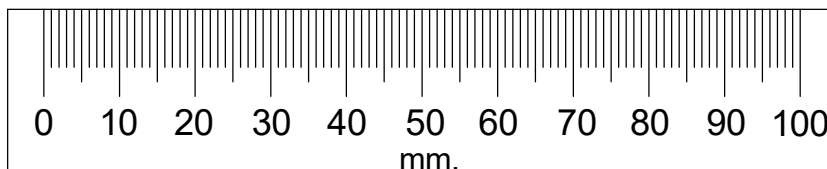

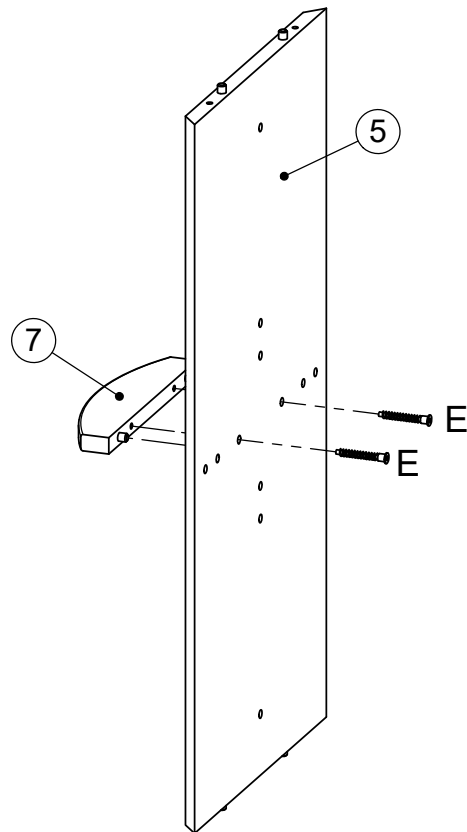
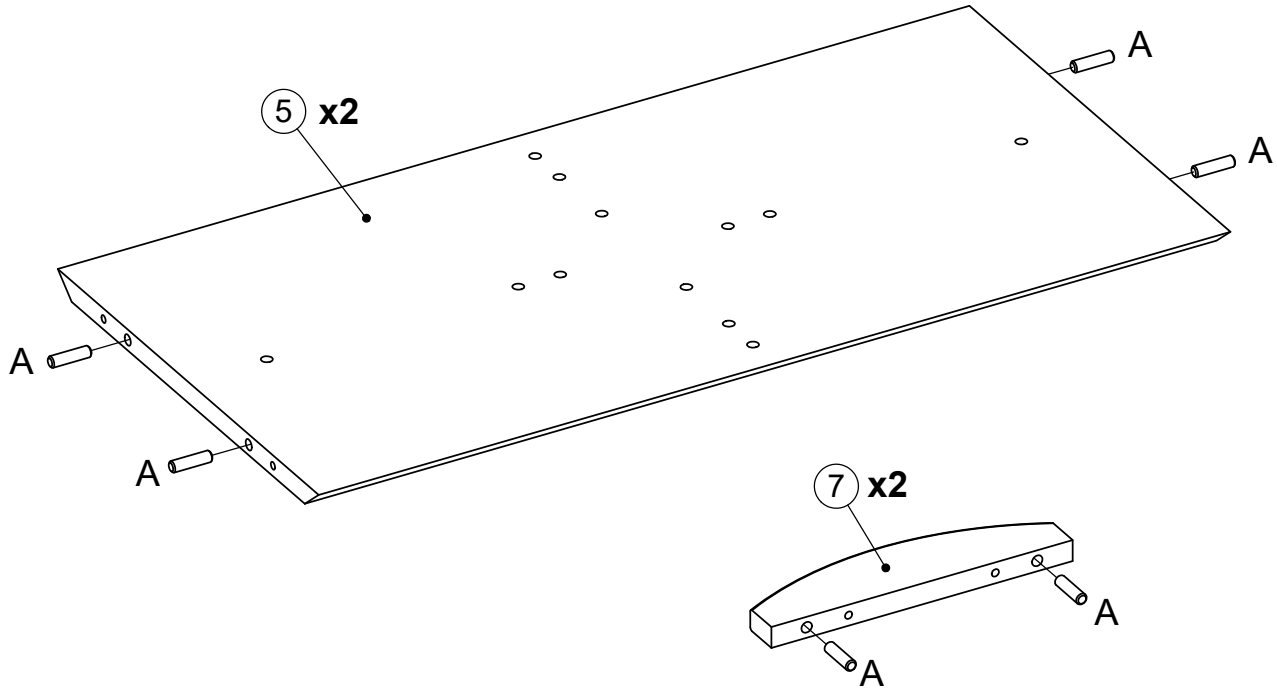

x2

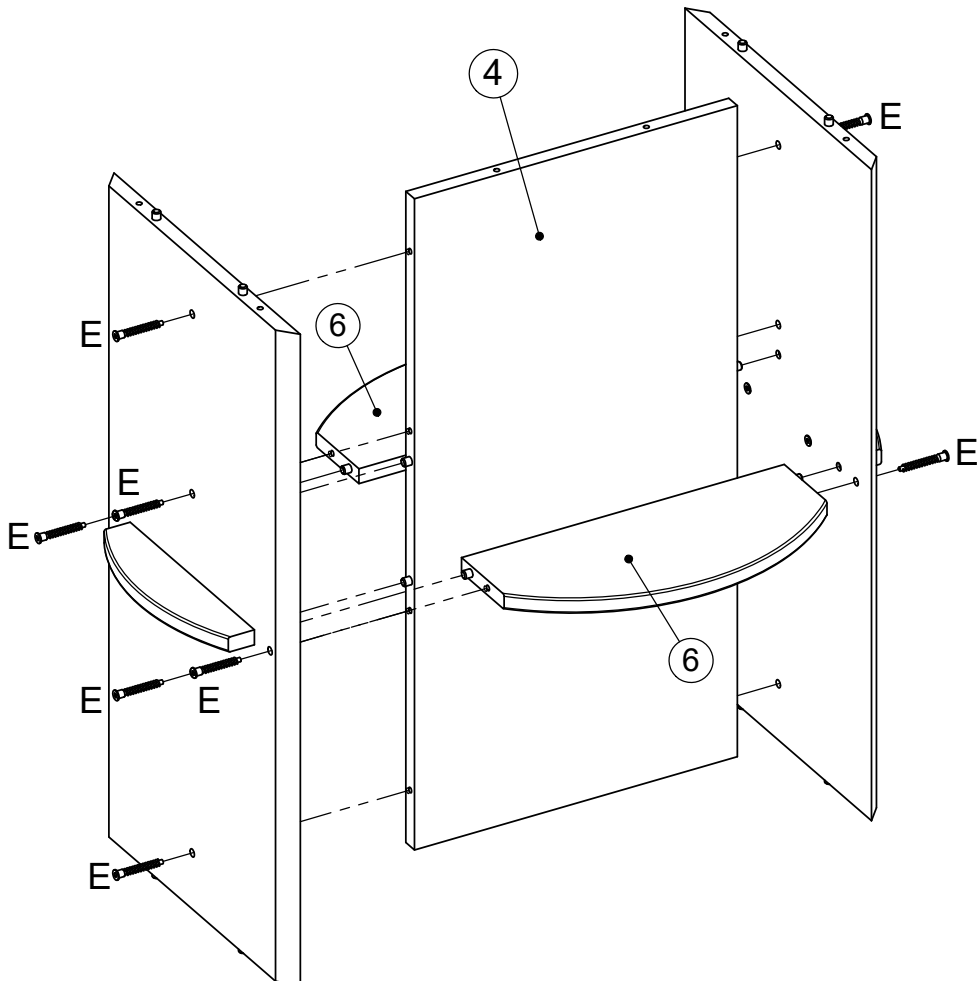
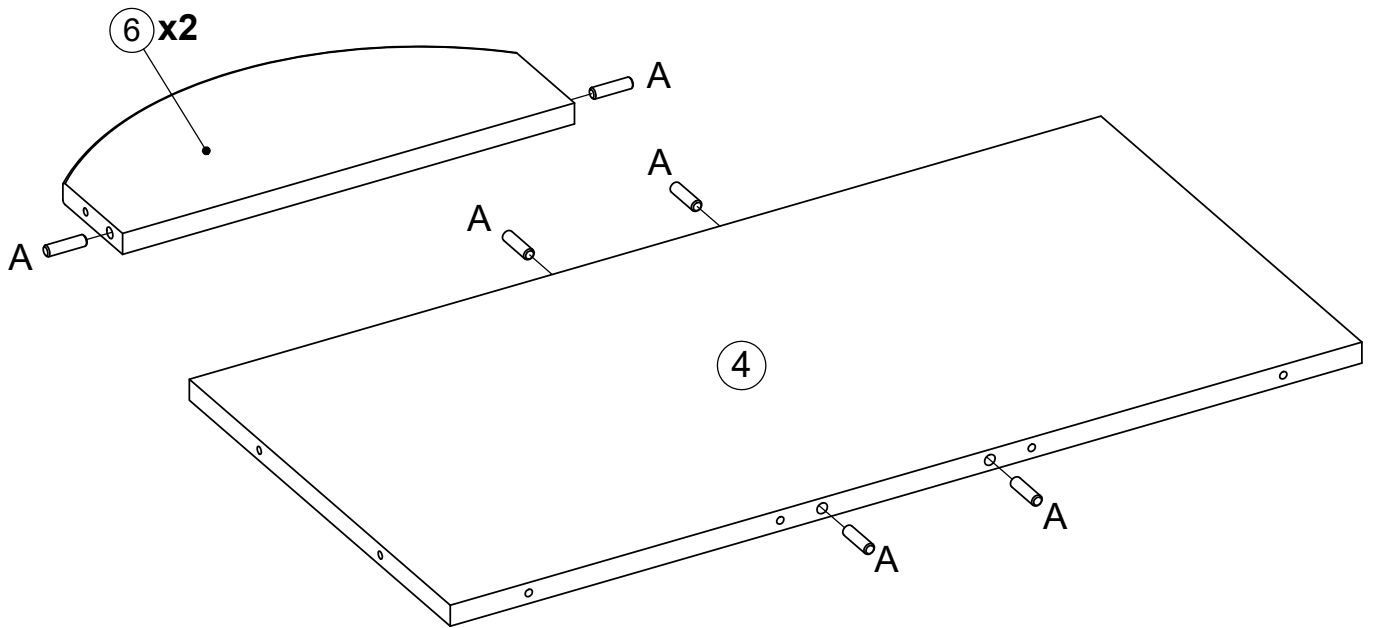

5

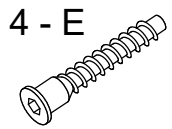

1-F

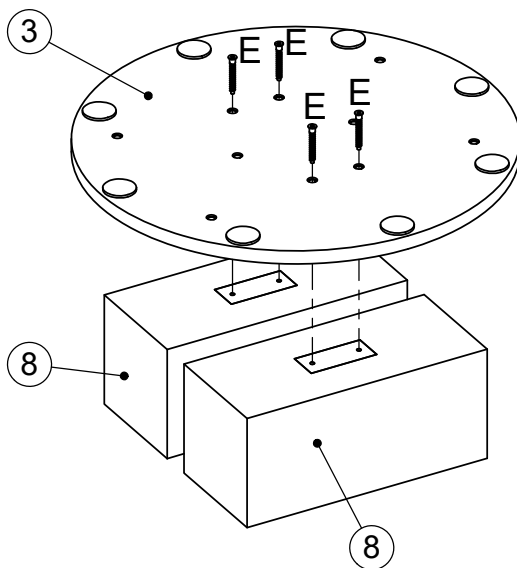

6

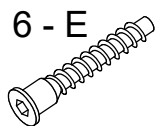

1-F

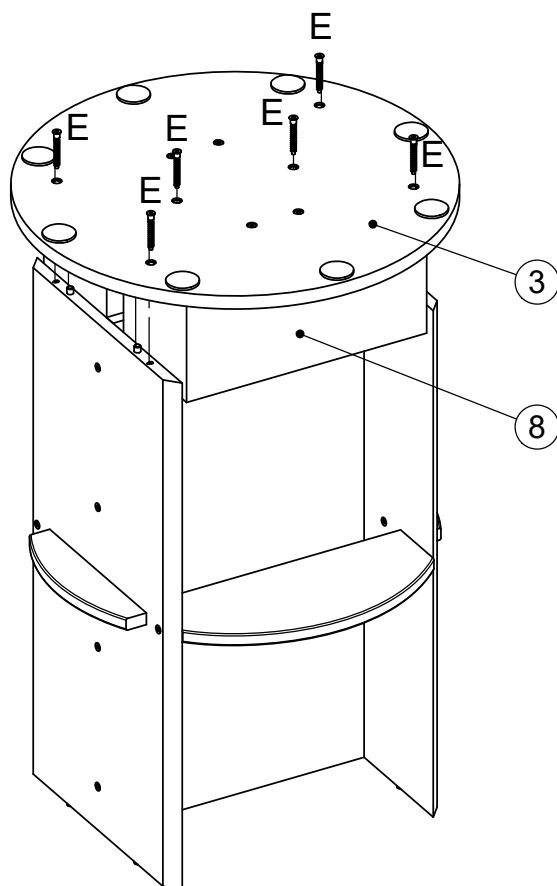
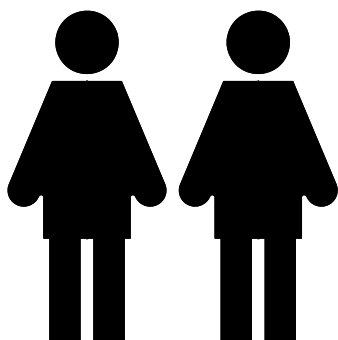

7

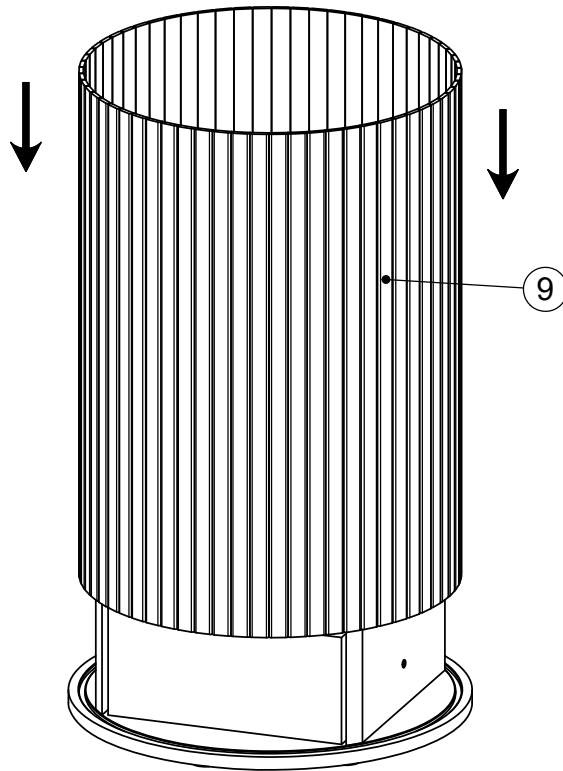

8

6 - E 2 - S 1 - F

A parts list for step 8. It includes: 6 - E (a screw), 2 - S (a sleeve), and 1 - F (an Allen key). The Allen key is shown in two orientations: an L-shaped one and a straight one with a T-handle.

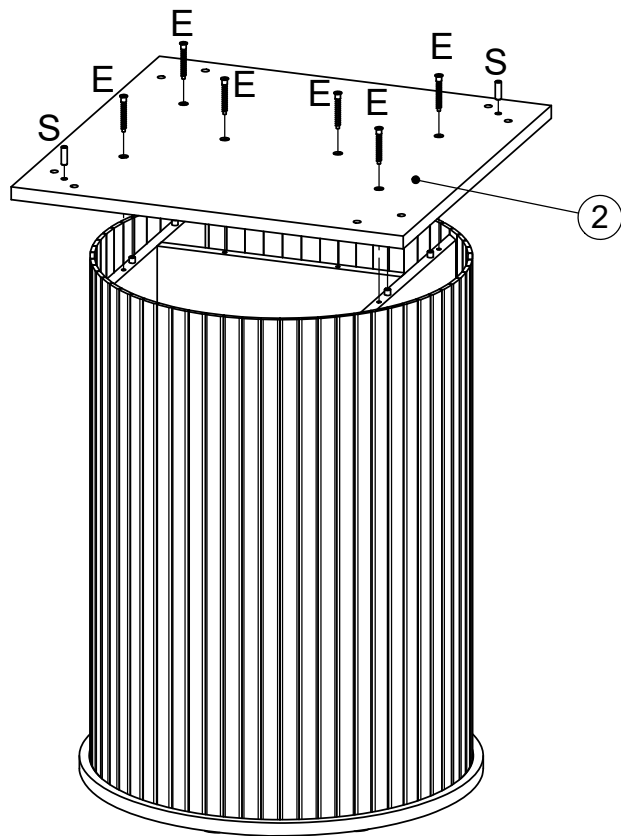

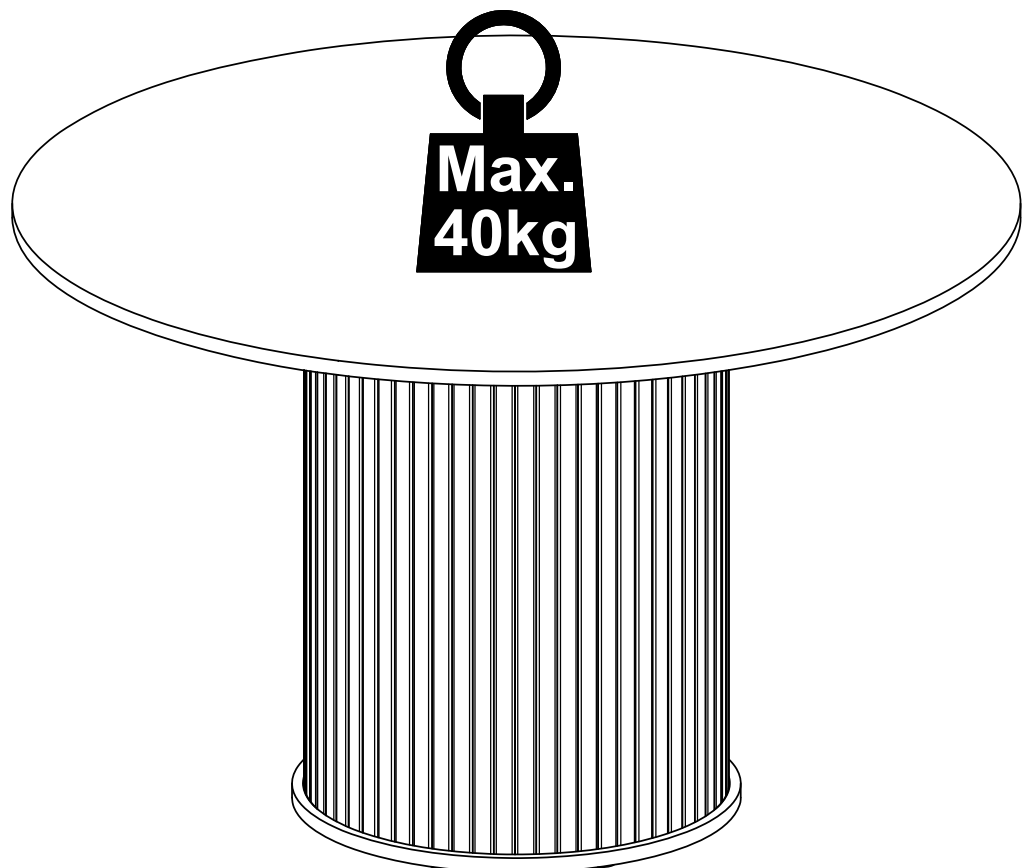
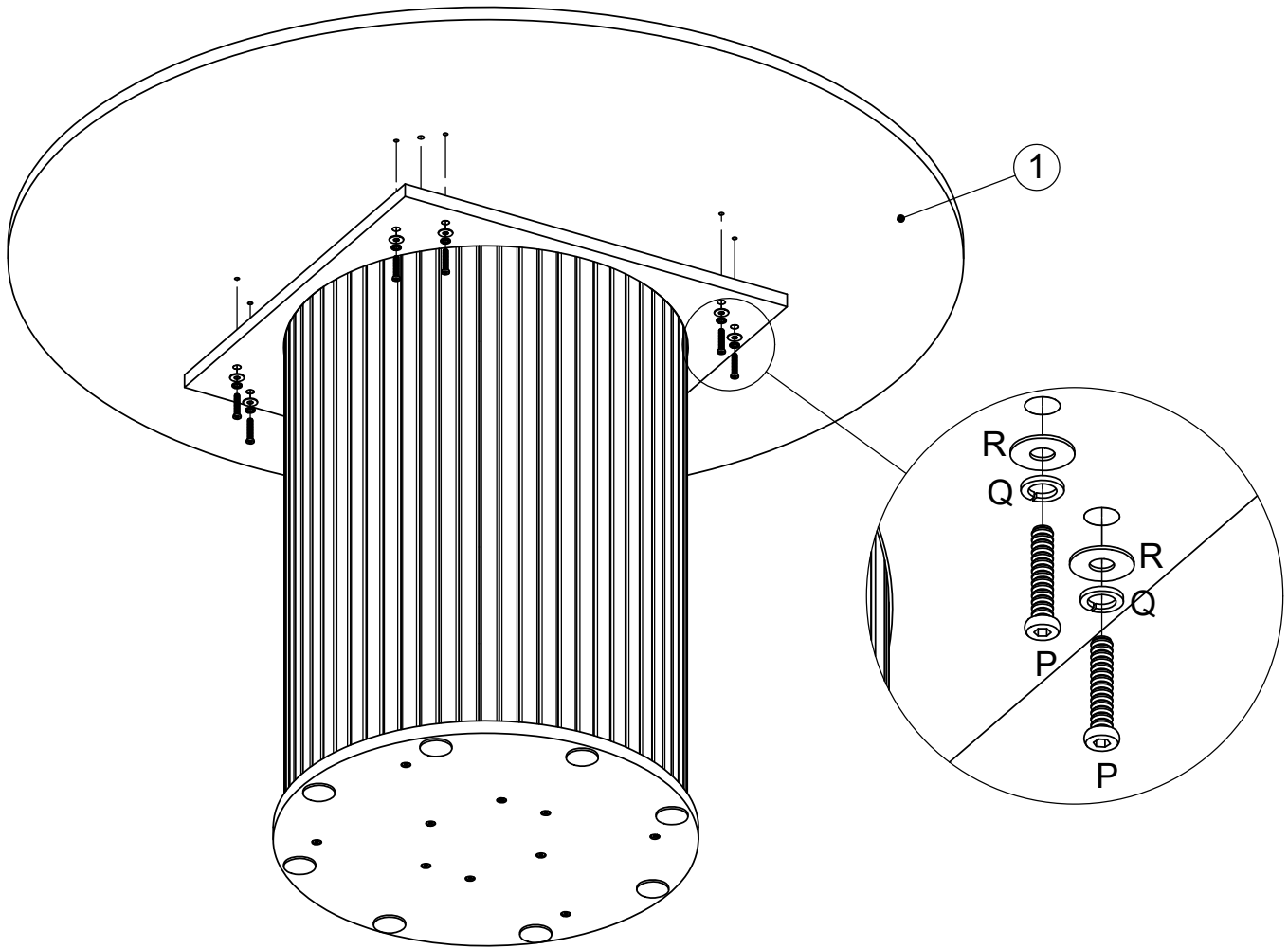



UK:

Always ensure the feet / felt pads provided with this product are suitable for your flooring.
Periodically check the position of any foot caps/felt pads used to ensure your floors are protected.

DE:

Wichtig : Bitte stellen Sie immer sicher , dass die mit diesem Produkt gelieferten FüÙe für Ihren Bodenbelag geeignet sind !
Bitte überprüfen Sie regelmäßig die Position der verwendeten Fußkappen oder Filzgleiter um sicherzustellen dass Ihre Böden geschützt sind !

ES:

Asegúrese siempre que los tapones de las patas de este producto son compatibles con su suelo.
Periódicamente revise que sus tapones y sus almohadillas de fieltro están correctamente colocadas para asegurar que su suelo esté protegido.

FR:

Assurez-vous toujours que les pieds/ patins fournis avec le produit sont compatibles avec le sol.
Contrôlez régulièrement la position des patins utilisés pour que vos sols soient protégés.

DK:

Sørg altid for at beskyttelse fødder / filt-puderne der følger med dette produkt, passer til Deres gulv.
Kontroller regelmæssigt placeringen at evt. beskyttelse fødder / filt-puder er korrekt placeret for bedste beskyttelse af gulvene.