

Before Getting Started

- Read the instructions carefully prior to assembling the product.
- When you open the package with a sharp tool like a cutter knife, be careful not to damage the components inside.
- Carefully remove all packaging materials and retain for future use.
- Keep all hardware parts and packaging out of reach of small children.
- Choose a clean, level, spacious assembly area. Avoid hard surfaces that may damage the product.
- Ensure that you have all required contents for complete assembly.
- Take care when lifting. Assemble the product in close proximity to where you intend to position the item.

WARNING: -Risk of suffocation! Keep any packaging materials away from children.
-Make sure power is completely off at the fuse box.
-Have your fixture installed by a qualified licensed electrician.

Cleaning & Maintenance

- For respective shade surfaces, use the appropriate cleansers, i.e. glass cleaner, acrylic polish, and wood polish.
- Clean with soft cloth and a mild detergent. DO not use abrasive cleaner.
- Periodically (every 90 days) make sure that the screws are fully tightened.
- Prolonged exposure to heat sources may cause glazing, melting and scorching, or even cause color to fade.

NOTE



Indoor use only.



Dry location only.

ilucezzo

INSTALLATION SHEET

67D211

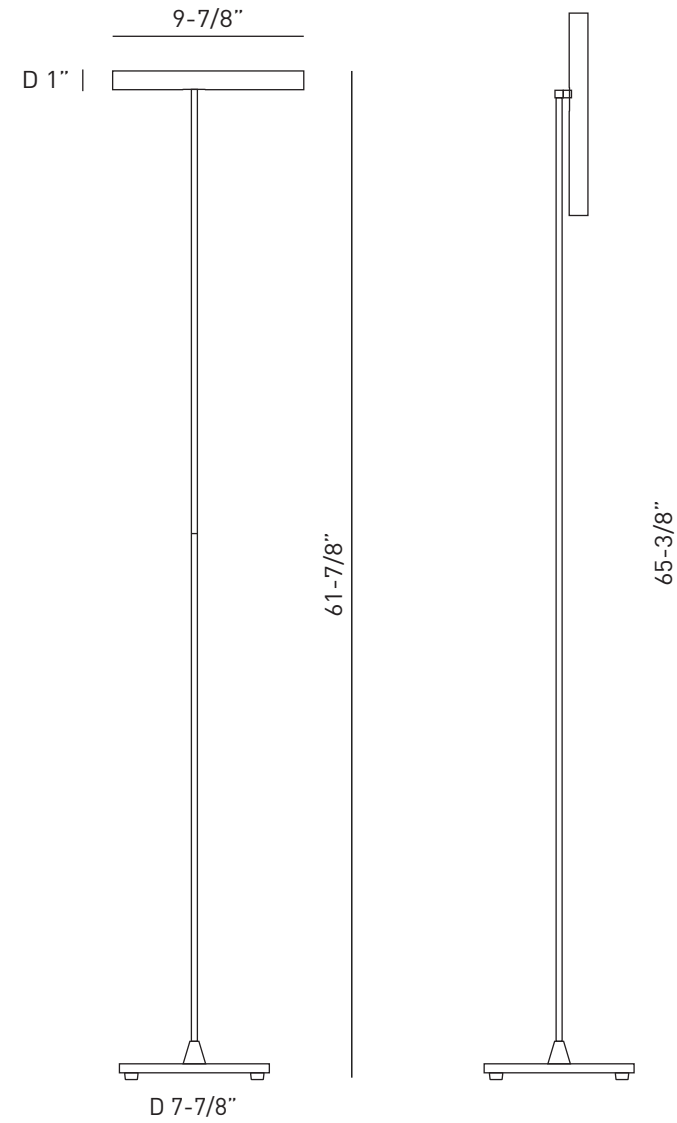

ZHONGSHAN GUZHEN LCZ LIGHTING & ELECTRICAL EQUIPMENTS FACTORY
NO.480, DONGAN NORTH RD., GUZHEN, ZHONGSHAN, GUANGDONG, CHINA
TEL: 86-760-22310601

ADDITIONAL PARTS (included)

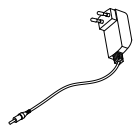

LED Driver
(x1)



Mounting Screws
(x4)

INSTALLATION INSTRUCTIONS

- 1 Remove floor lamp from carton very carefully and remove all excess packaging.

- 2
 - a. Connect the top and bottom rods by rotating the bottom rod. Do Not pinch or cut wire during assembly.
 - b. Connect the lamp pole to the base with 4 Mounting Screws.

Please note: make sure that the front of the lamp is in the opposite side of the plug.

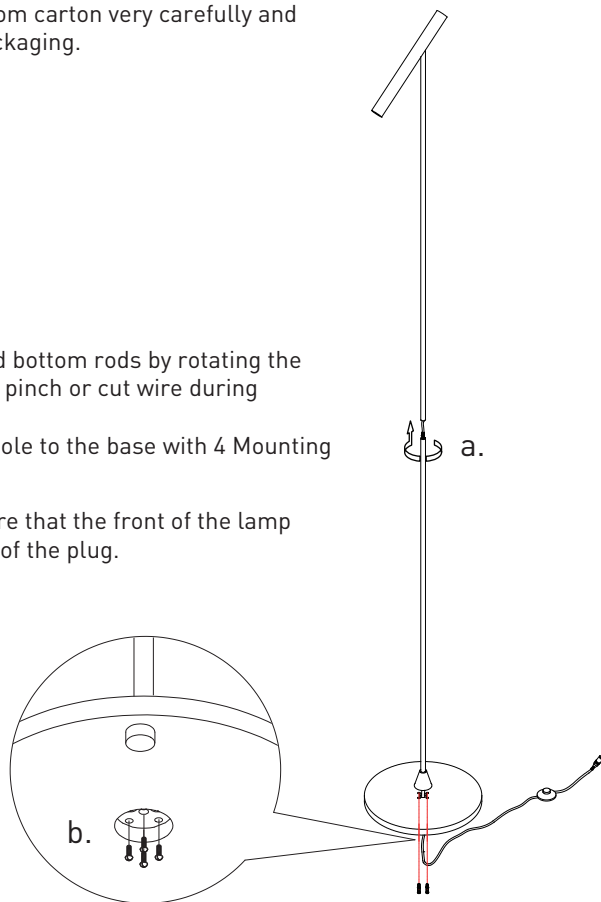

- 3 Pulling the wire through the base and to make sure the wire not slack. Secure the cable using the cable restrainer by tightening the two screws.

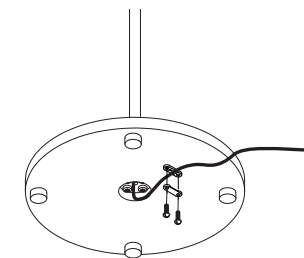

- 4
 - a. Connect the wire.
 - b. Connect the plug of lamp to AC power socket. (Make sure the switch is "OFF".)

- 5 Switch on the lamp.

