

# ASSEMBLY INSTRUCTIONS

ITEM NO.WF302657

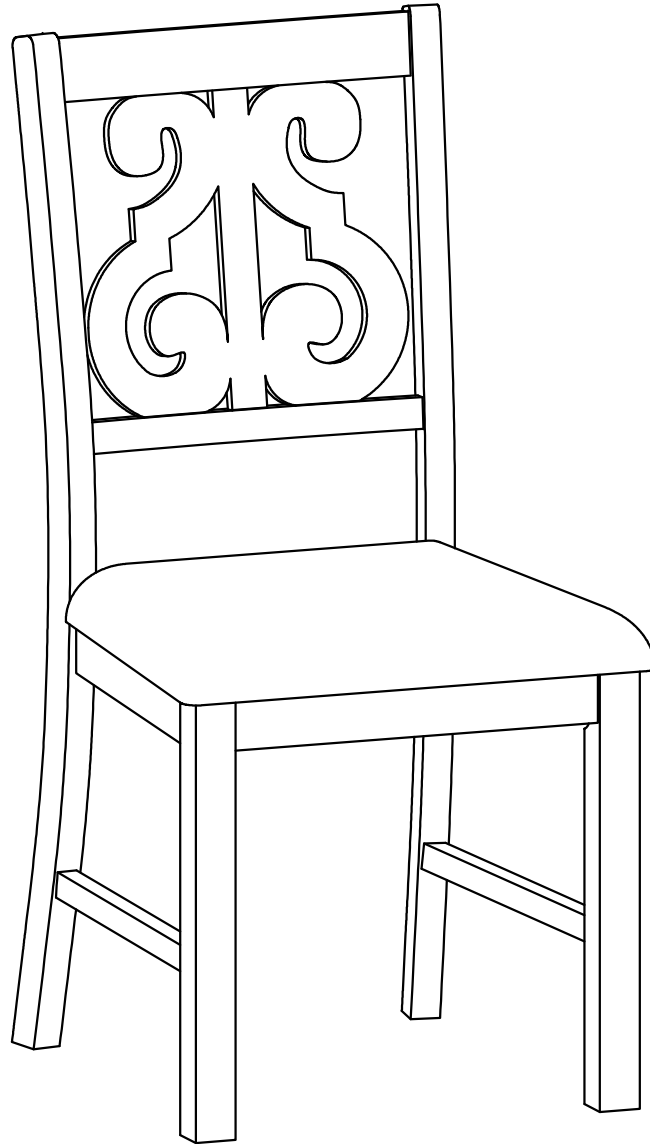



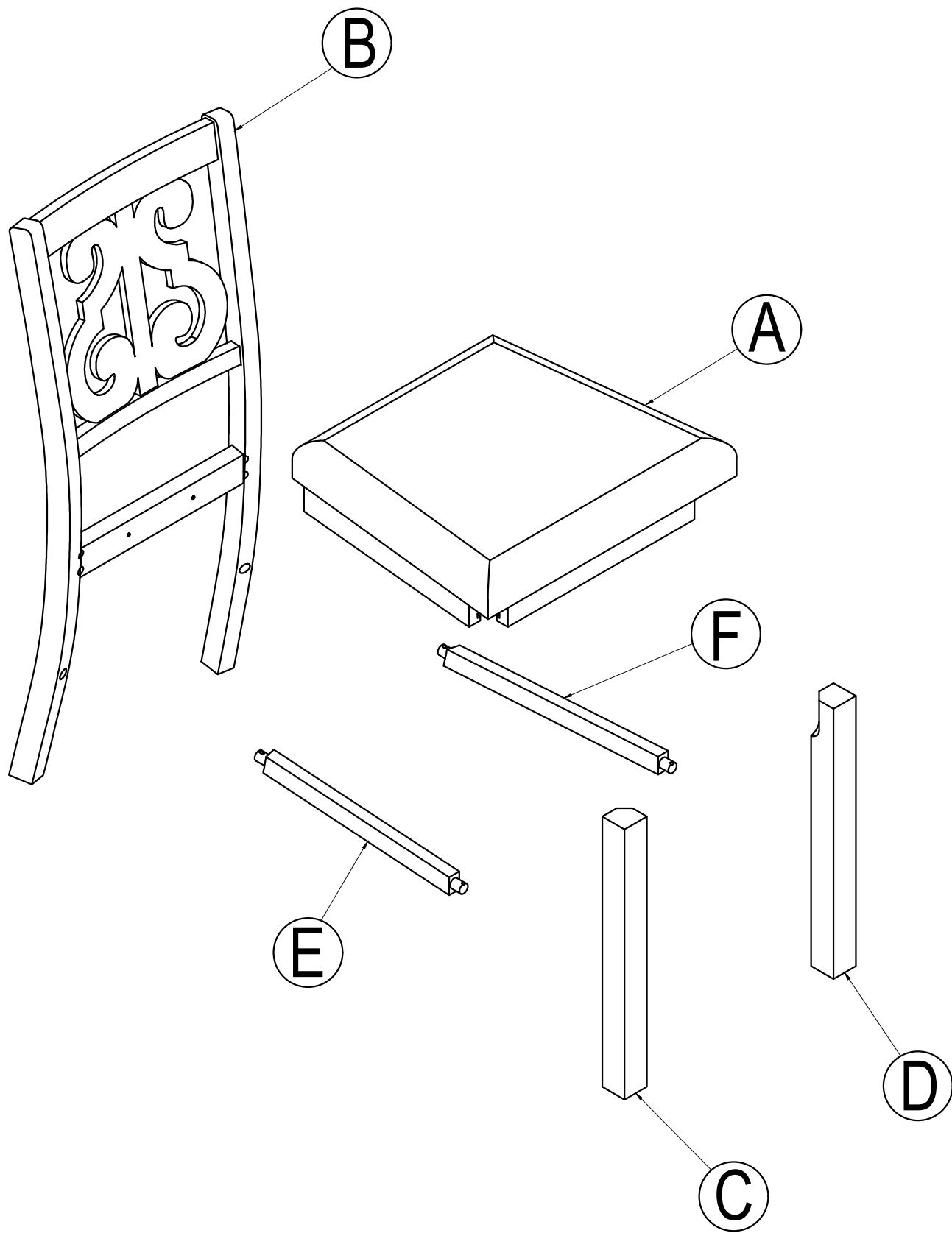

## IMPORTANT NOTE :

- ① PLACE ALL PARTS ON A CLEAN AND SMOOTH SURFACE SUCH AS A RUG OR CARPET TO AVOID THE PARTS FROM BEING SCRATCHED.
- ② BEFORE YOU BEGIN,KINDLY FOLLOW THE ASSEMBLY INSTRUCTIONS STEP BY STEP.
- ③ DO NOT TIGHTEN ALL SCREWS AND BOLTS UNTIL THE CHAIR IS FULLY SET-UP.

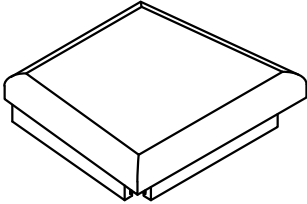

# Part List

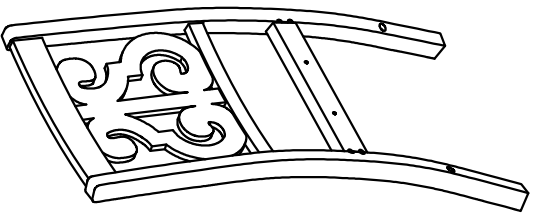
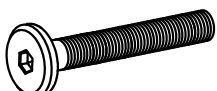
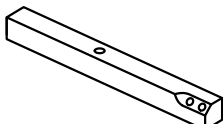
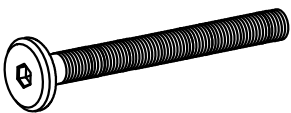
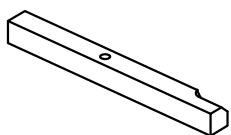
# Hardware List

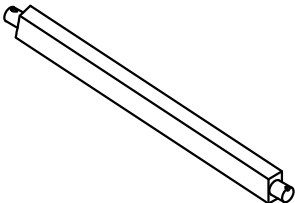
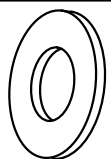
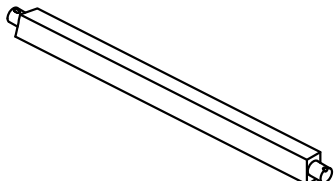
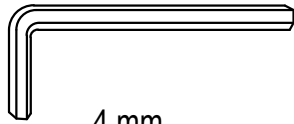
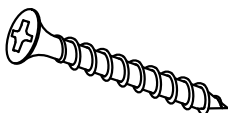
<p>(A)</p> 	<p>(1)</p>  <p>Ø 1/4" x 40mm</p>
<p>CUSHION SEAT (4PC)</p>	<p>BOLT (8 pcs)</p>
<p>(B)</p> 	<p>(2)</p>  <p>Ø 1/4" x 55 mm</p>
<p>CHAIR BACK (4PCS)</p>	<p>BOLT (16 pcs)</p>
<p>(C)</p> 	<p>(3)</p>  <p>Ø 1/4" x 75 mm</p>
<p>FRONT LEGS (4PCS) (Left)</p>	<p>BOLT (16 pcs)</p>
<p>(D)</p> 	<p>(4)</p>  <p>Ø5/16" x 13 mm</p>
<p>FRONT LEGS (4PCS) (Right)</p>	<p>FLAT WASHER (40 pcs)</p>
<p>(E)</p> 	<p>(5)</p>  <p>Ø5/16" x 19 mm</p>
<p>SIDE STRETCHERS (4PCS) (Left)</p>	<p>LOCK WASHER (40 pcs)</p>
<p>(F)</p> 	<p>(6)</p>  <p>4 mm</p>
<p>SIDE STRETCHERS (4PCS) (Right)</p>	<p>ALLEN KEY (1 pc)</p>
	<p>(7)</p>  <p>#4 x 38 mm</p>
	<p>WOOD SCREWS (16 PCS)</p>

**STEP 1:**

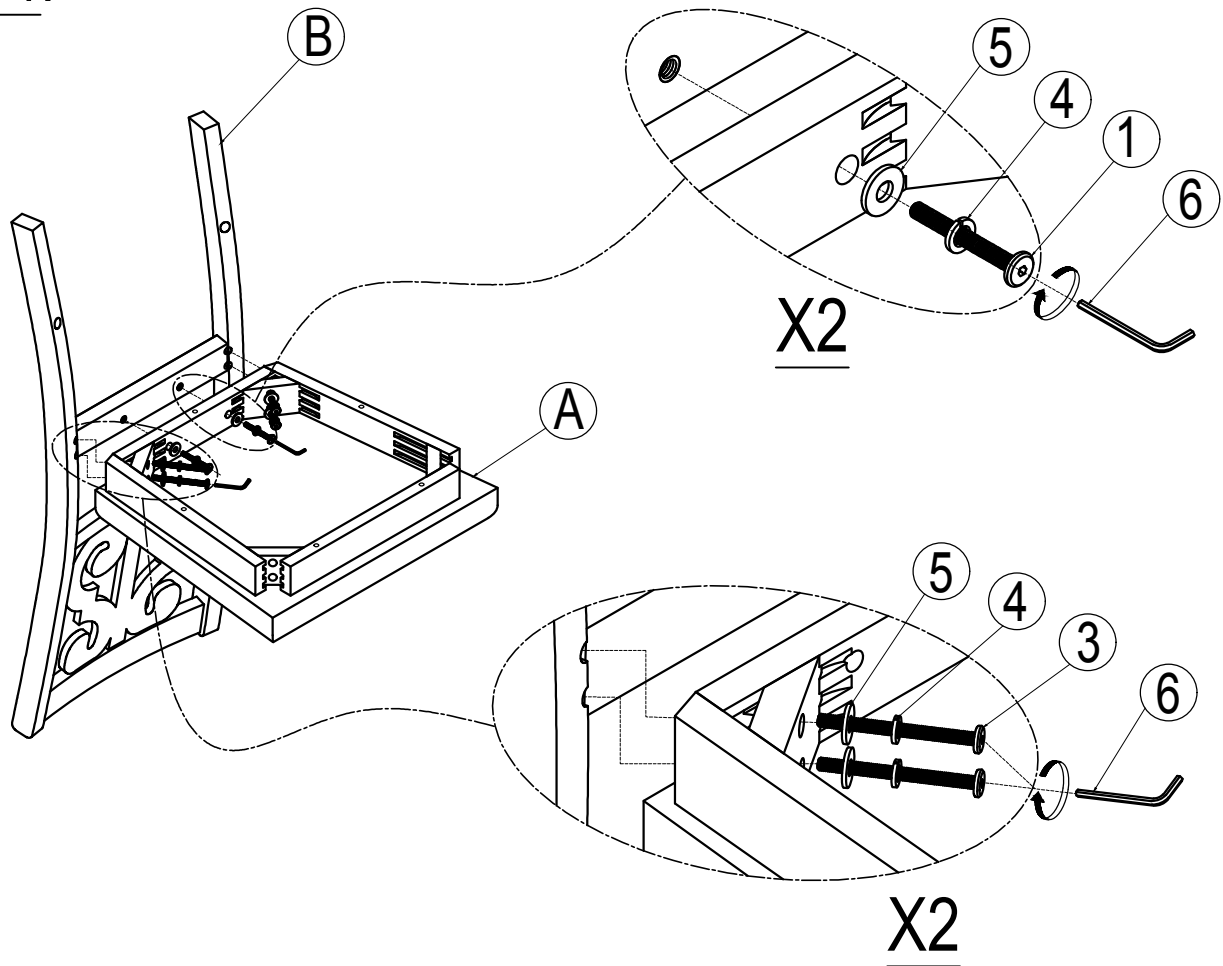

**STEP 2:**

