

# CHAISE LOUNGE

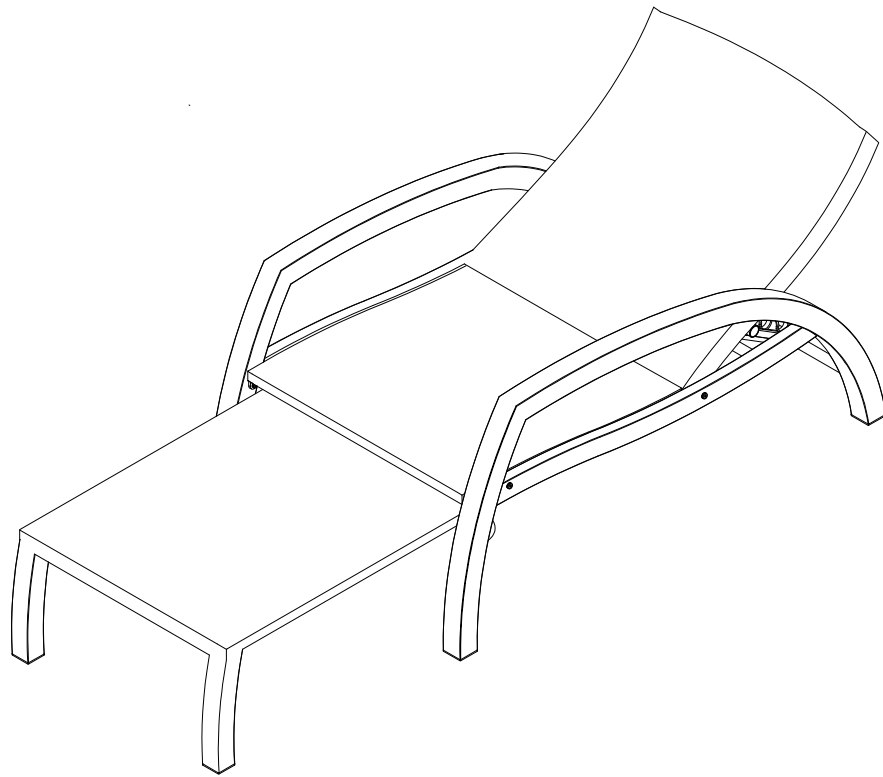







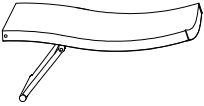
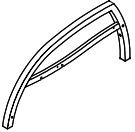
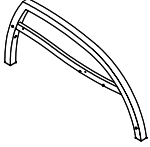
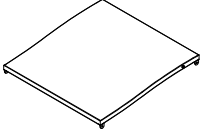
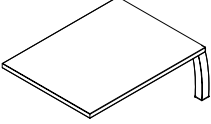
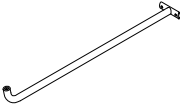
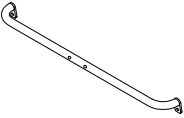
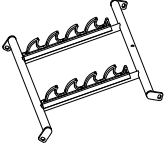



**Read the instructions before use of this product.**





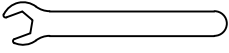

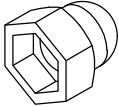
Please keep this instruction manual for future reference.

## PARTS & HARDWARE LIST

PART	FIGURE	DESCRIPTION	QTY
A		Back Panel	1PC
B		Right Arm Panel	1PC
C		Left Arm Panel	1PC
D		Seat Panel 1	1PC
E		Seat Panel 2	1PC
F		Center Connector	1PC
G		Arm Connector	1PC
H		Adjustment Bar	1PC

## PARTS & HARDWARE LIST

PART	FIGURE	DESCRIPTION	QTY
J		Bolt M6*50	6PCS
L		Bolt M6*35	3PCS
M		Bolt M6*25	10PCS
N		Washer	19PCS
O		Nut	2PCS
P		Allen Key	1PC
Q		Wrench	1PC
R		Bolt Cap	19PCS
S		Nut Cap	2PCS
T		Plastic Washer	2PCS

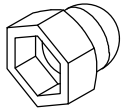
EXTRA			
PART	FIGURE	DESCRIPTION	QTY
J		Bolt M6*50	1PC
L		Bolt M6*35	1PC
M		Bolt M6*25	2PCS
N		Washer	1PC
O		Nut	1PC
R		Bolt Cap	1PC
S		Nut Cap	1PC

**ATTENTION:**

Keep children away during assembly. This item contains small parts that can be dangerous for children. Children should always be under direct adult supervision while using this product.

Do not discard any of the packaging until you have checked that you have all of the parts and fittings required.

Carefully remove the contents from the package. If any parts are missing, do not attempt to use the product until they have been obtained.

Make sure that each bolt needed for all steps matches the corresponding figure ensure proper assembly.

## STEP 1

Lay left arm panel(C) down on a soft flat surface, such as carpet, as shown below. Attach the seat panel 1(D) to left arm panel(C) using bolts M6\*25(M) and washers(N).

Please do not fully tighten bolts until unit is fully assembled.

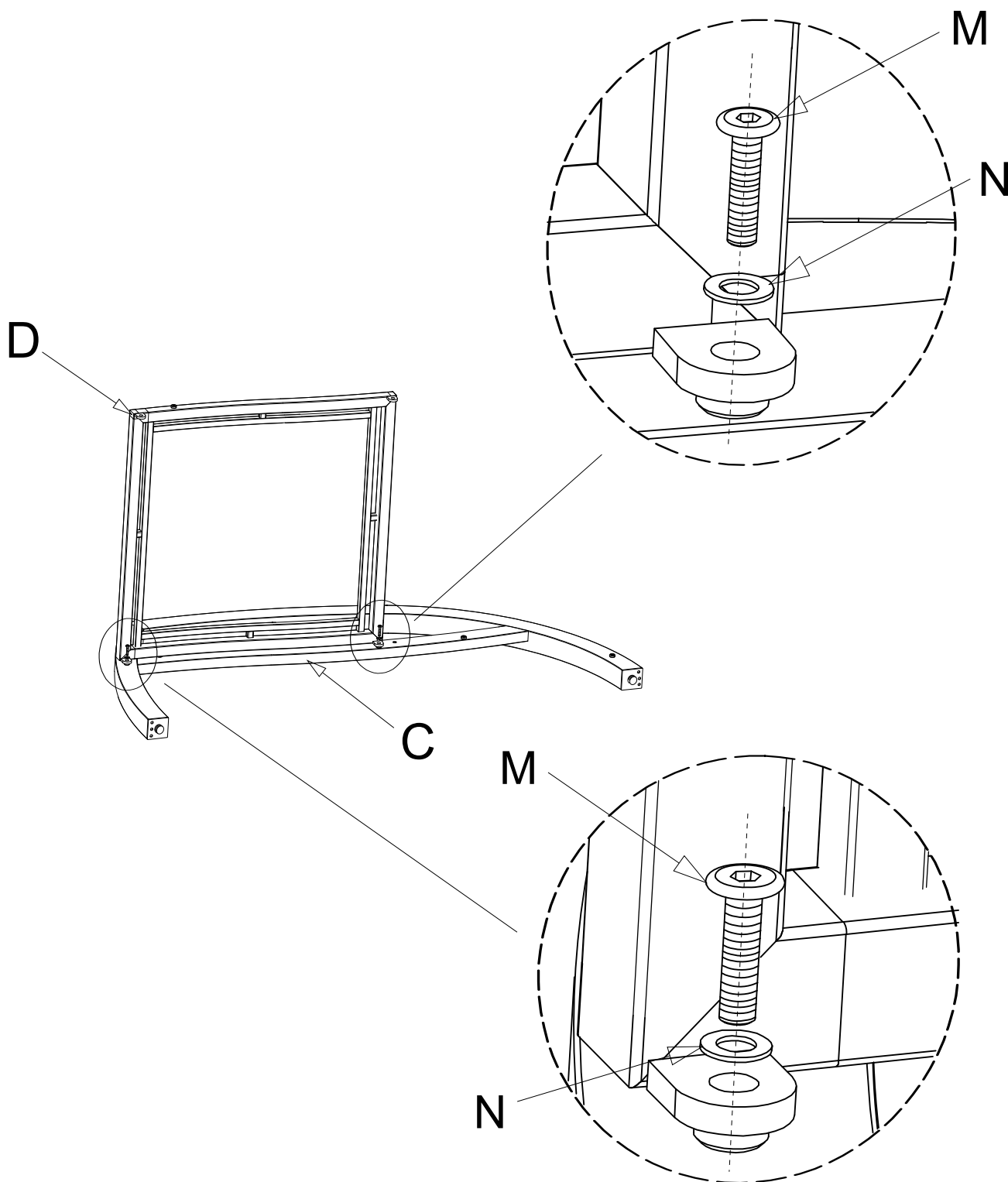

## STEP 2

Attach right arm panel(B) to assembled unit(C&D) using bolts M6\*25(M) and washers(N).

Please do not fully tighten bolts until unit is fully assembled.

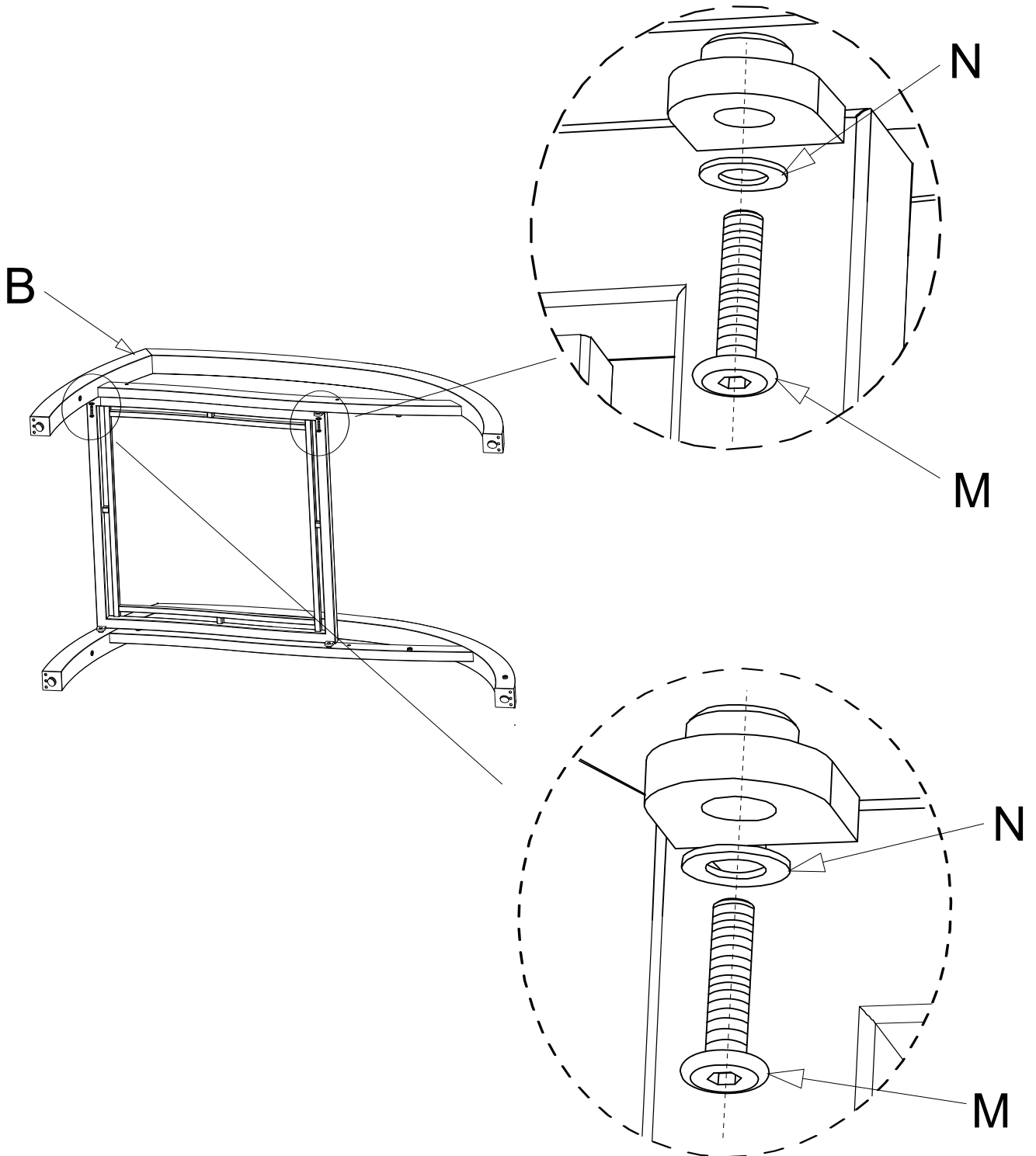

### STEP 3

Screw the assembled unit(B, C&D) using bolts M6\*50(J) and washers(N).

Please do not fully tighten bolts until unit is fully assembled.

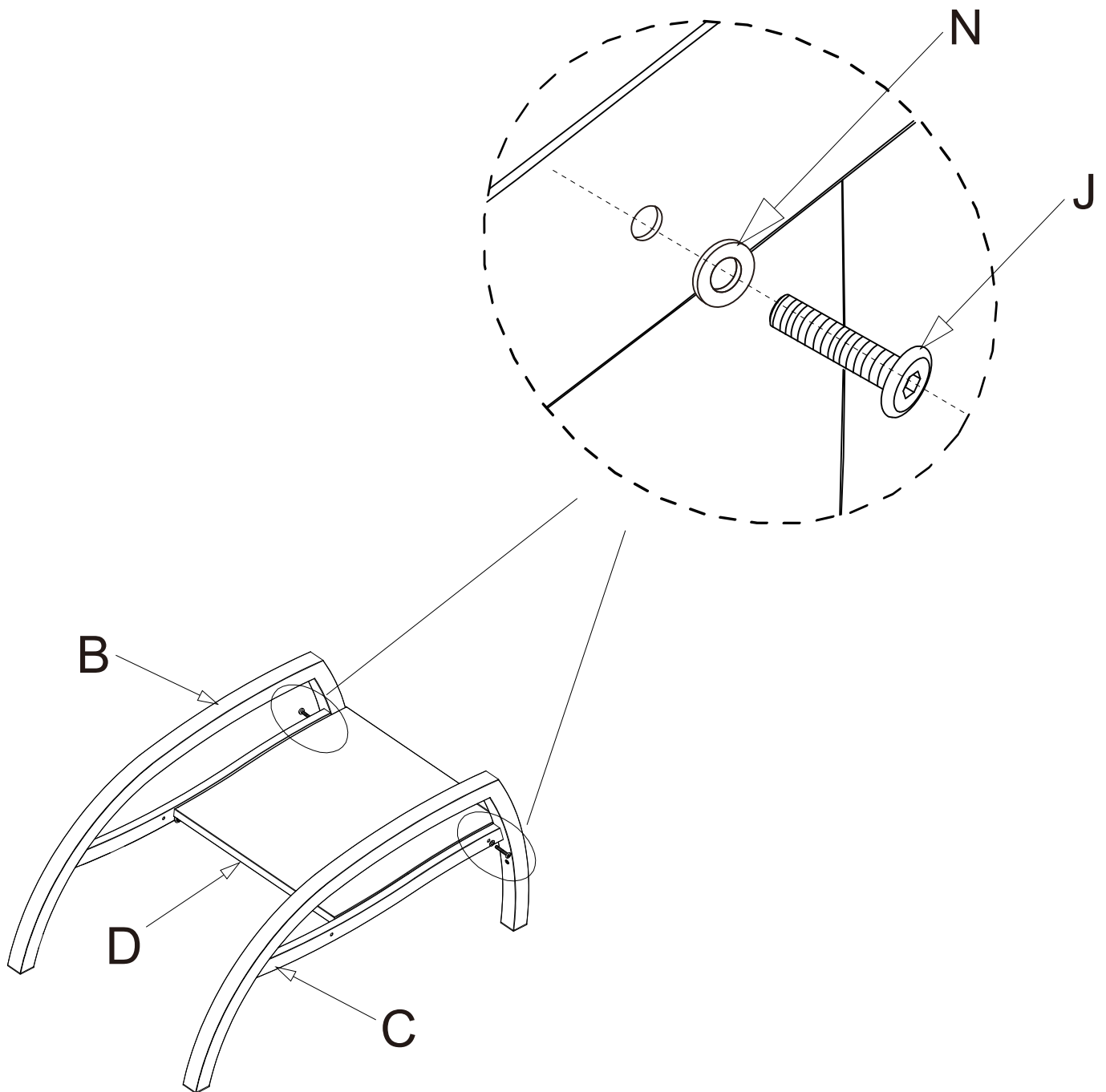

## STEP 4

Attach adjustment bar(H) to assembled unit(B, C&D) using bolts M6\*25(M) and washers(N).

Please do not fully tighten bolts until unit is fully assembled.

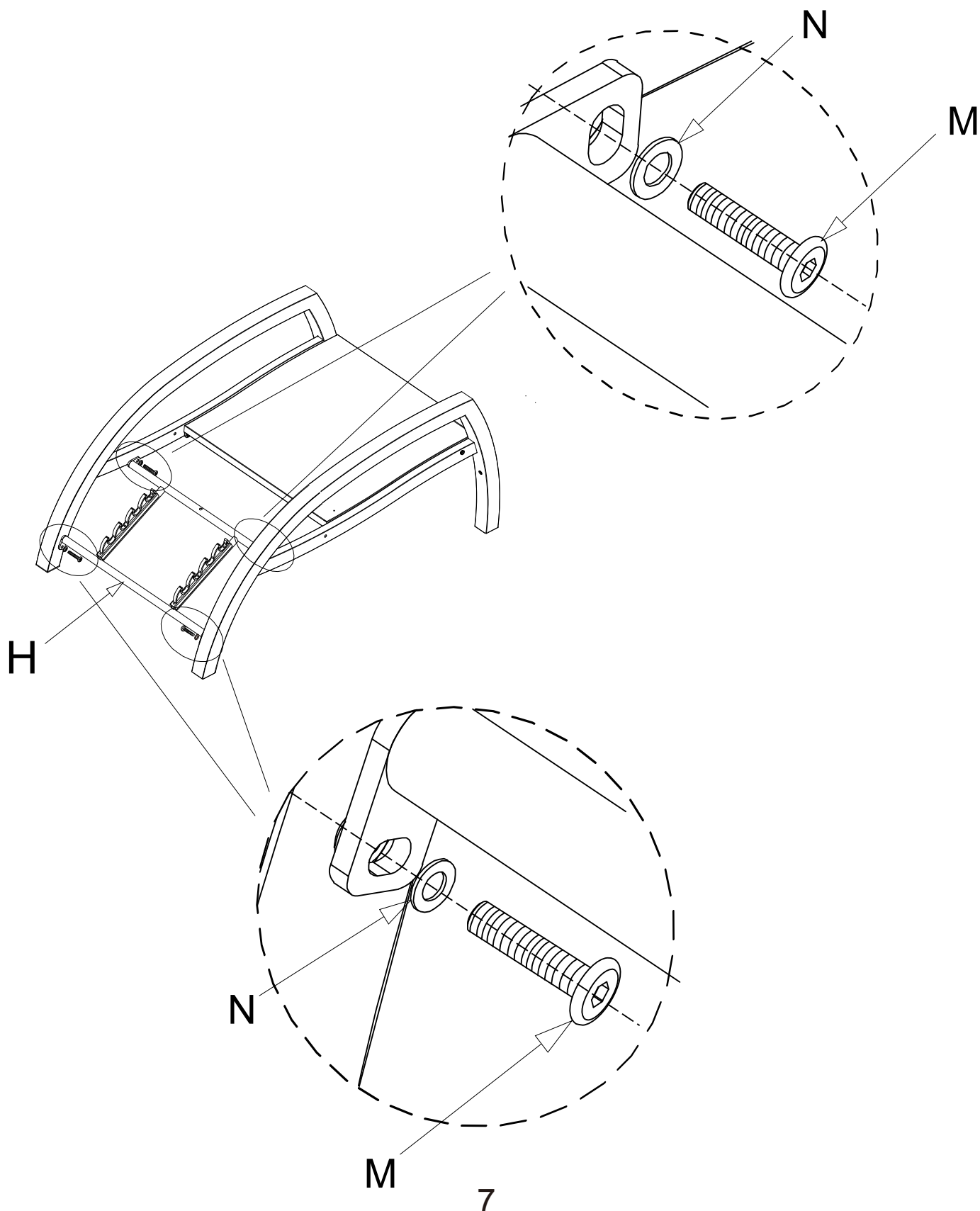

## STEP 5

Attach the center connector(F) to arm connector(G) using bolts M6\*35(L), washers(N) and nuts(O).

Please do not fully tighten bolts until unit is fully assembled.

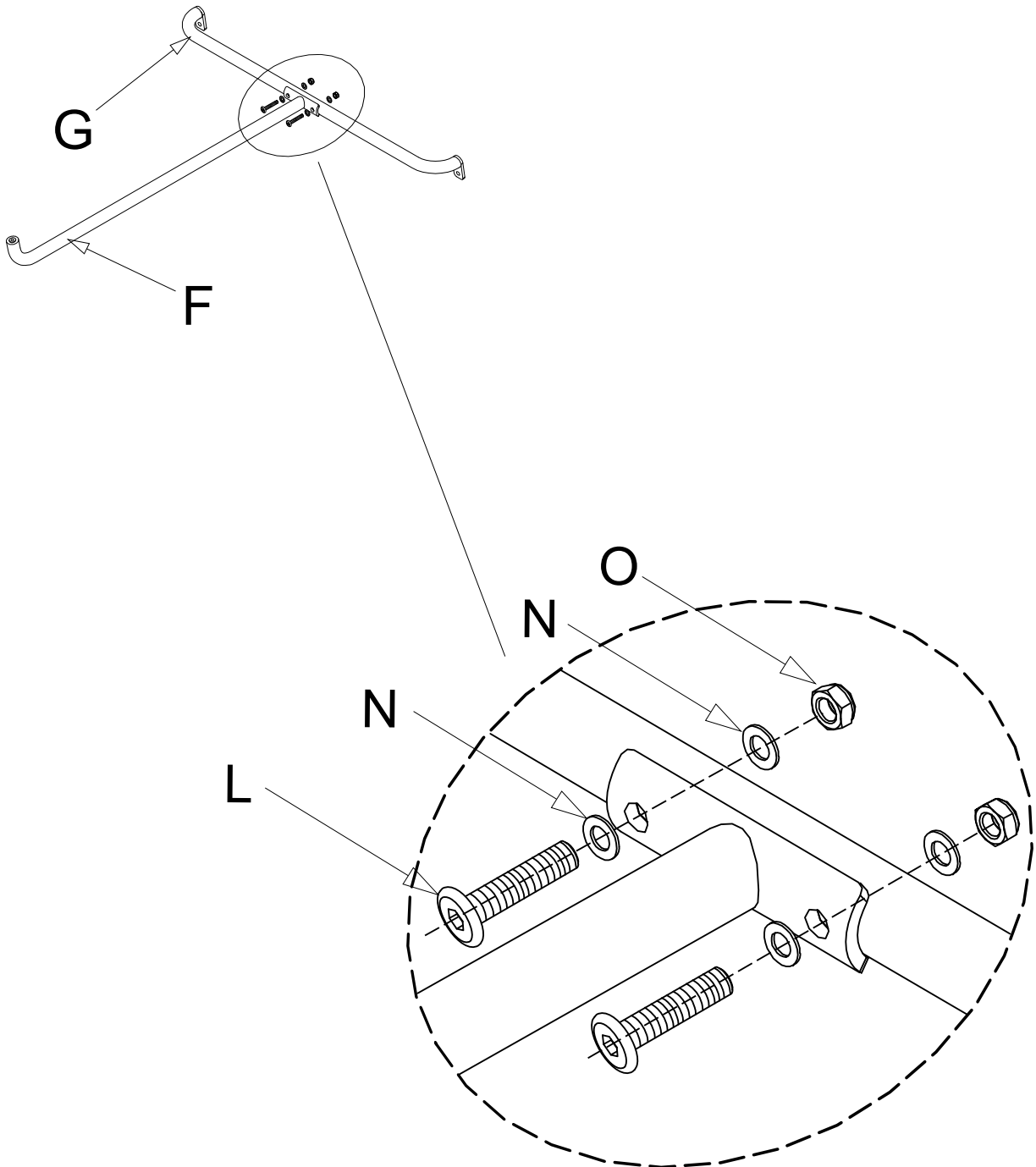

## STEP 6

Lay the assembled unit(B, C, D&H) down on a soft flat surface as shown below. Attach the assembled unit(F&G) to assembled unit(B, C, D&H) using bolts M6\*35(L), bolts M6\*25(M) and washers(N).

Please do not fully tighten bolts until unit is fully assembled.

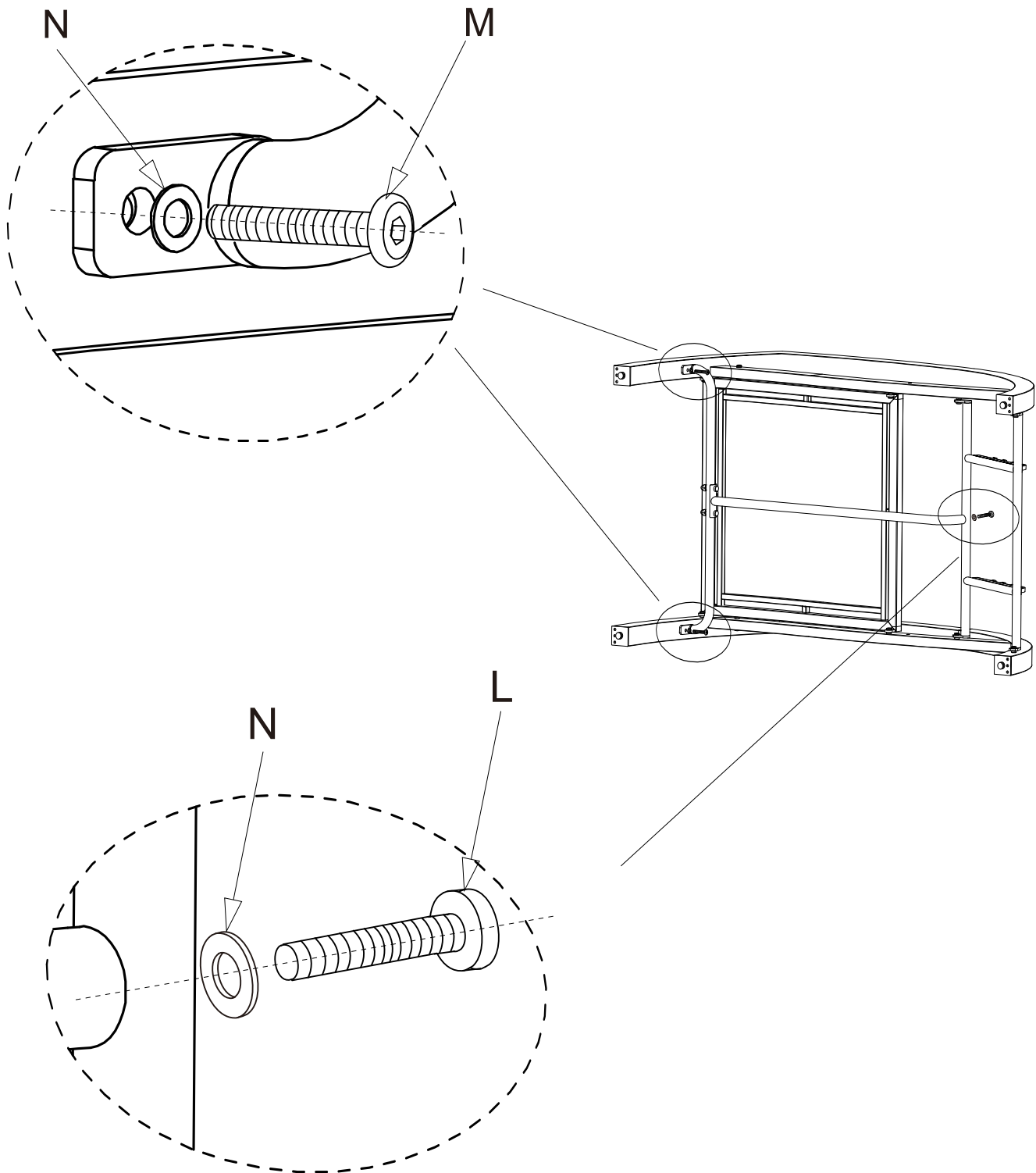

## STEP 7

Put seat panel 2(E) into the assembled unit(B, C, D, F, G&H) as shown below. Attach them using bolts M6\*50(J) and plastic washers(T).

Please fully tighten the two bolts.

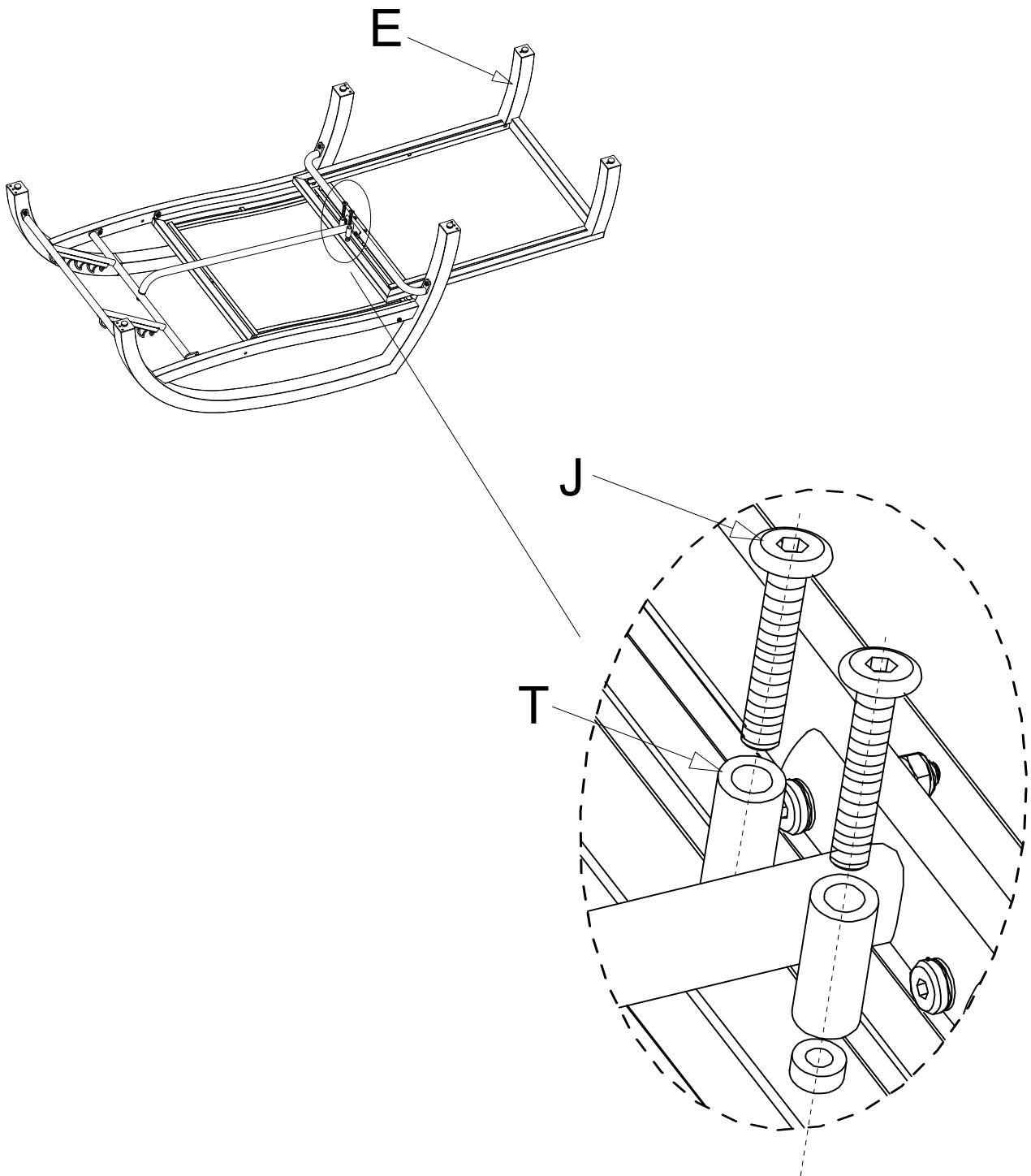

## STEP 8

Attach back panel(A) to assembled unit(B, C, D, E, F, G&H) using bolts M6\*50(J), washers(N), and bolt caps(R).

Please fully tighten all bolts using allen key(P) and wrench(Q), and cover bolt caps(R) and nut caps(S) at this time.

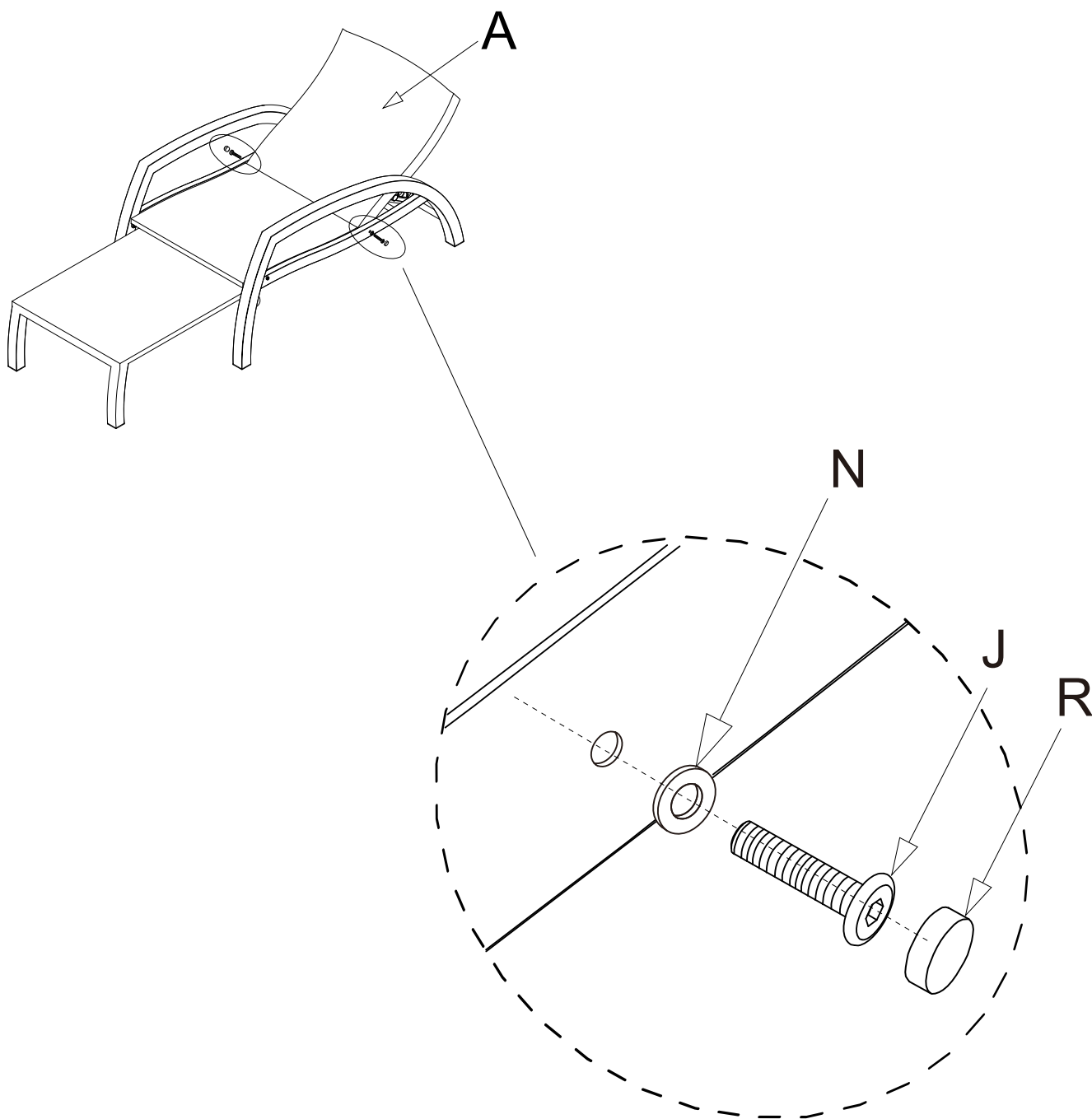

STEP 9

Enjoy your chaise lounge.

