





# ASSEMBLY INSTRUCTION

020-916 Kelsey Round End Table

## HARDWARE LIST

A		Bolt	Ø5/16"*2-1/2"	4 PCS
B		Bolt	Ø5/16"*1-1/4"	8 PCS
C		Lock Washer	Ø5/16"	12 PCS
D		Flat Washer	Ø5/16"*19D	12 PCS
E		Allen Key	100*50*4mm	1 PC

## PART LIST

1	Table Top	1 PC
2	Pedestal	1 PC
3	Pedestal Base	1 PC
4	Bridge Panel	1 PC

## IMPORTANT NOTES

- . Place all wooden parts on clean and smooth surface such as rug or carpet to prevent the parts from being scratched.
- . Check to be sure that you have all parts and hardware.
- . Remove all wrapping materials, including staples and packing straps before you start to assemble.
- . Do not tighten all screws and bolts until completely assembled.
- . Keep all hardware out of the reach of children

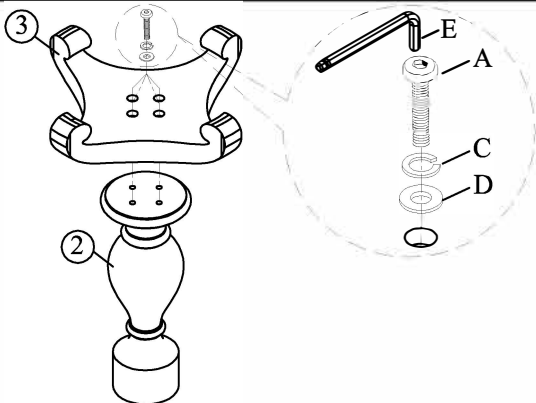

STEP 1. Attach the pedestal base (3) to the pedestal (2) as shown in the picture using bolt (A), lock washer (C), flat washer (D) and tighten with allen key (E).

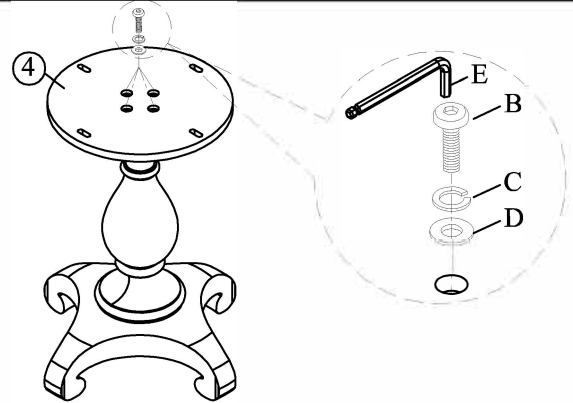

STEP 2. Attach the bridge panel (4) to the pedestal (2) as shown in the picture using bolt (B), lock washer (C), flat washer (D) and tighten with allen key (E).

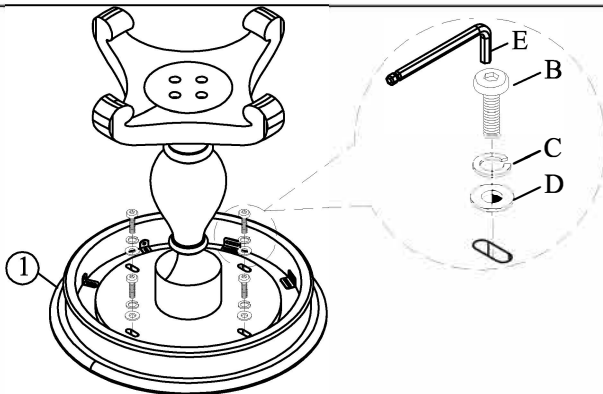

STEP 3. Put the table top (1) upside down on clean soft surface attach the pedestal assembly to the table top (1) as shown in the picture using bolt (B), lock washer (C), flat washer (D) and tighten with allen key (E).

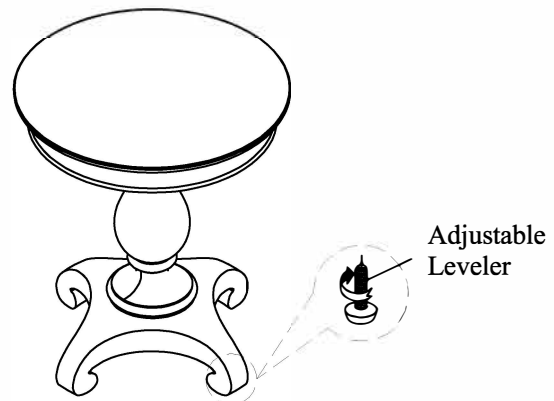

STEP 4. Carefully turn the table up. Adjust leveler if needed to level table on uneven floor.

MADE IN VIETNAM