

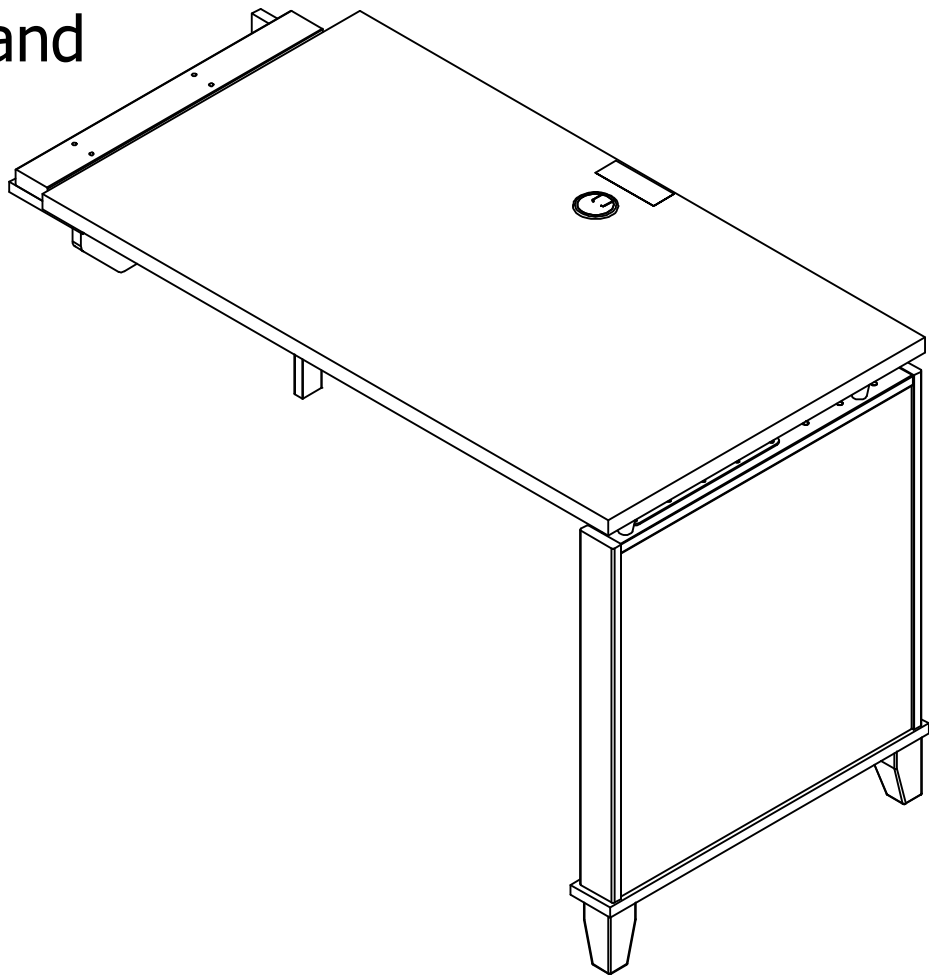

Sit To Stand



Get Ready to Assemble

For best results, keep these tips in mind:

- ① We know you want to finish this assembly as quickly as possible, but trust us: you'll have a better experience if you take it one step at a time.
- ② Give yourself some room to work near where you want the fully assembled product.
- ③ If your floor isn't carpeted, assemble this product on the empty carton to avoid scratching.
- ④ Do you have a friend who owes you a favor? Some steps may go a little easier with a second set of hands.

DOs

- ✔ Use a #2 Phillips head screwdriver (or other handheld tools as indicated)
- ✔ Wear safety glasses at all times during assembly
- ✔ Carefully follow the instructions in this guide and complete all steps in order
- ✔ Give us a call if you're having trouble with a particularly tricky step

DON'Ts

- ✘ We know power tools are quick and easy, but you shouldn't use them when assembling this product (unless otherwise specified)
- ✘ Never move your furniture with items inside or resting on the surface
- ✘ Do not attempt to use this product before all steps have been completed

IMPORTANT SAFETY INFORMATION



PLEASE READ WARNINGS

Improper use can cause safety hazards, or damage to your furniture and household items.

Warning	Do	Don't	Why it's important
Serious injury may occur.	<ul style="list-style-type: none">Assemble following all instructions using all indicated parts and hardware provided.	<ul style="list-style-type: none">Do not move unit when loaded.Do not load with a television or other heavy equipment.Do not exceed the maximum load limits stated in the instructions.Do not sit or stand on adjustable height work surface.	Improper assembly, use or loading can lead to product instability, tip-over or collapse.
Serious injury may occur.	<ul style="list-style-type: none">Maintain 1 inch (25mm) clearance between desk and all other furniture at all times.	<ul style="list-style-type: none">Do not place hands close to the mechanism when lifting or lowering the work surface.	Pinch points exist in the mechanism and may be created by placing the desk too close to other furniture and objects.

Advertencia	Hacer	No	Por qué es importante
Se pueden producir lesiones graves.	<ul style="list-style-type: none">Ensamble siguiendo todas las instrucciones utilizando todas las piezas y ferretería indicados provistos.	<ul style="list-style-type: none">No mueva la unidad cuando esté cargada.No cargue con un televisor u otro equipo pesado.No exceda los límites máximos de carga establecidos en las instrucciones.No se siente ni se pare sobre una superficie de trabajo de altura ajustable.	El ensamblaje, uso o carga inadecuados pueden provocar inestabilidad del producto, vuelco o colapso.
Se pueden producir lesiones graves.	<ul style="list-style-type: none">Mantenga un espacio de 1 pulgada (25 mm) entre el escritorio y todos los demás muebles en todo momento.	<ul style="list-style-type: none">No coloque las manos cerca del mecanismo cuando levante o baje la superficie de trabajo.	Existen puntos de pellizco en el mecanismo y pueden crearse colocando el escritorio demasiado cerca de otros muebles y objetos.

IMPORTANT SAFETY INFORMATION



PLEASE READ WARNINGS

Improper use can cause safety hazards, or damage to your furniture and household items.

Avertissement	Faire	Ne le fais pas	Pourquoi c'est important
Des blessures graves peuvent survenir.	<ul style="list-style-type: none">Assemblez en suivant toutes les instructions en utilisant toutes les pièces et le matériel indiqués fournis.	<ul style="list-style-type: none">Ne déplacez pas l'unité lorsqu'elle est chargée.Ne chargez pas avec un téléviseur ou un autre équipement lourd.Ne dépassez pas les limites de charge maximale indiquées dans les instructions.Ne vous asseyez pas ou ne vous tenez pas debout sur une surface de travail à hauteur réglable.	Un assemblage, une utilisation ou un chargement incorrects peuvent entraîner une instabilité du produit, un renversement ou un effondrement.
Des blessures graves peuvent survenir.	<ul style="list-style-type: none">Maintenez un espace de 1 pouce (25 mm) entre le bureau et tous les autres meubles en tout temps.	<ul style="list-style-type: none">Ne placez pas les mains près du mécanisme lorsque vous soulevez ou abaissez la surface de travail.	Des points de pincement existent dans le mécanisme et peuvent être créés en plaçant le bureau trop près d'autres meubles et objets.

Get to know your Boards

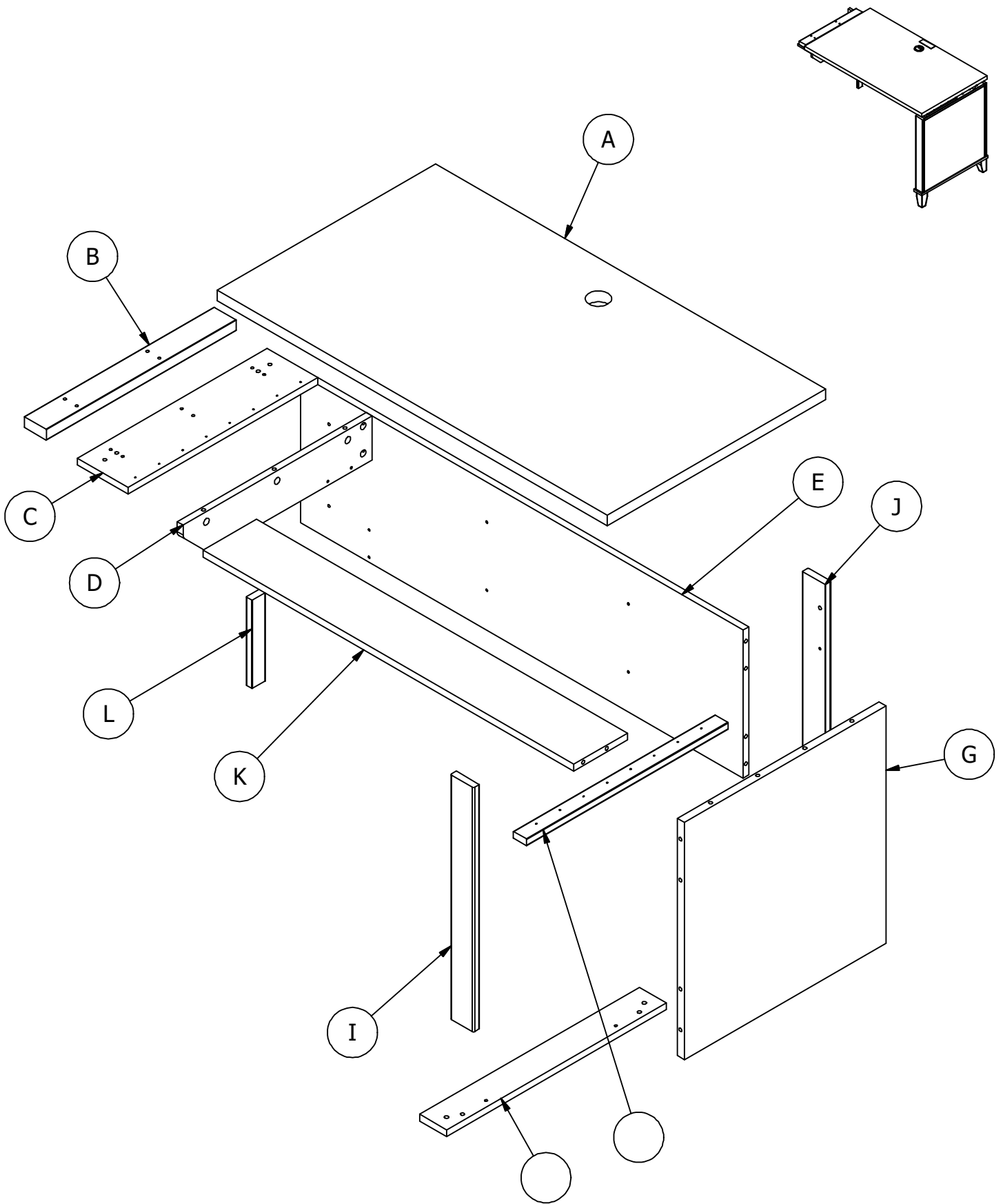

Get to know your Fasteners

Fasteners are shown actual size.

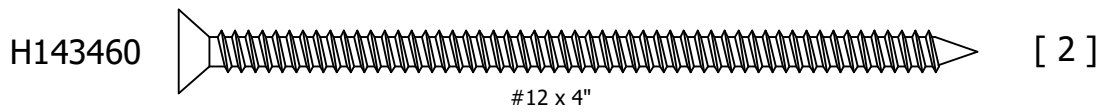
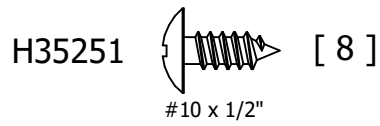
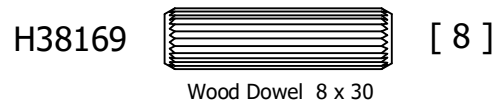
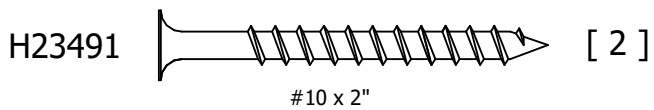
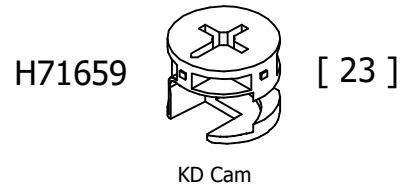
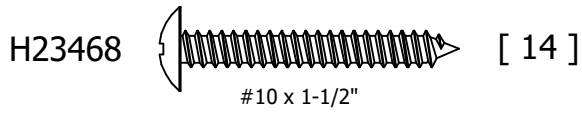
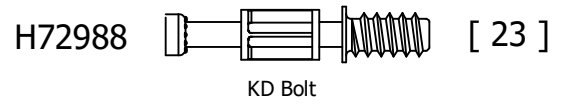
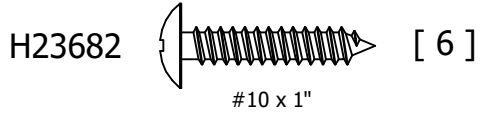

Get to know your Hardware

Hardware not to scale.

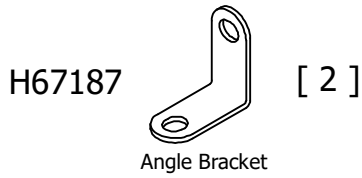
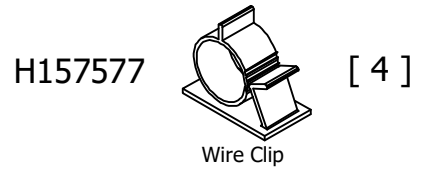
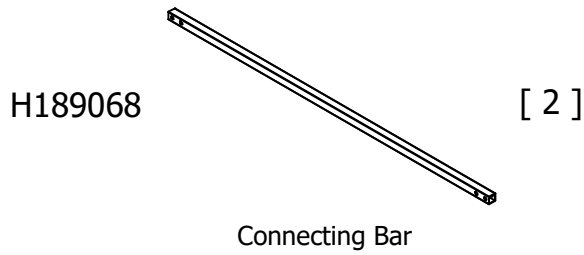
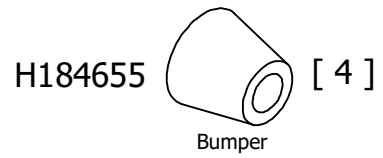
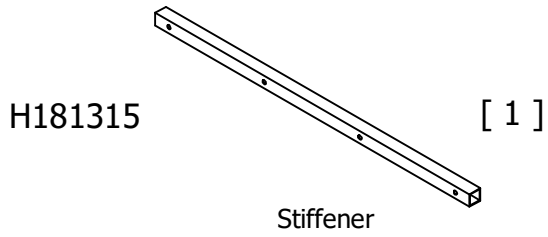

Q184665 Sit to Stand Mechanism

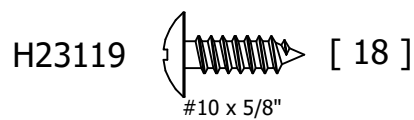
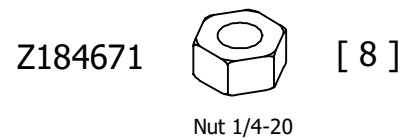
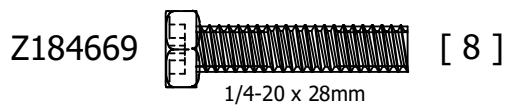
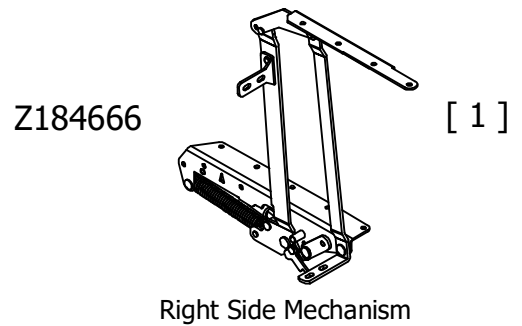
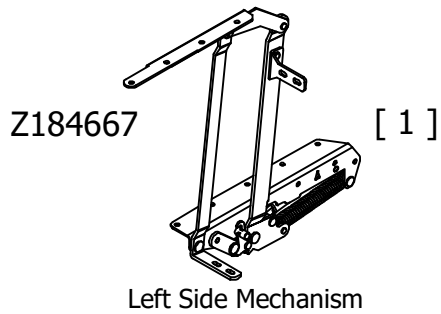

Get to know your Hardware

Hardware not to scale.

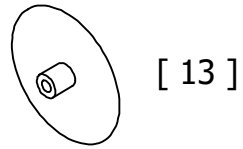

[13]

Cover Cap

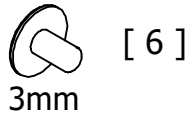

[6]

3mm

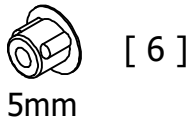

[6]

5mm

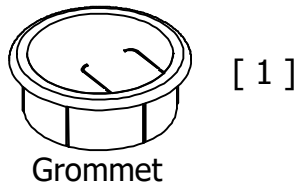

[1]

Grommet

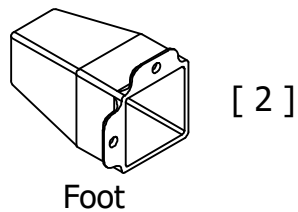

[2]

Foot

Option 1

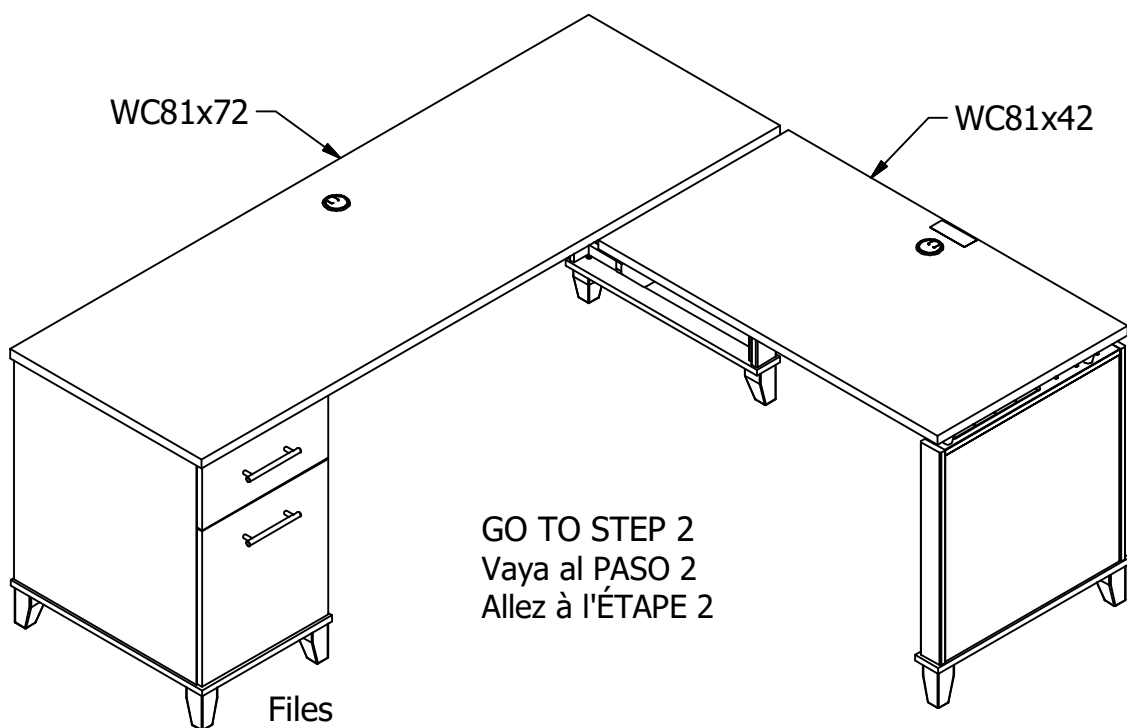

Option 2

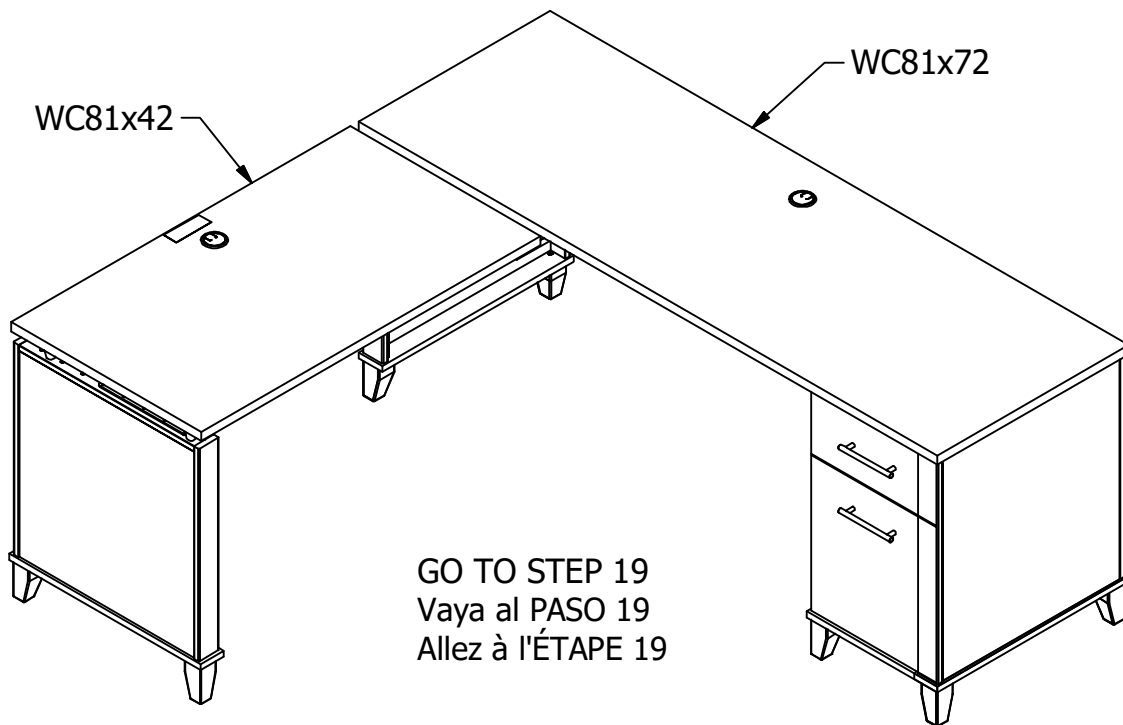

STEP 2

Prepare Rails

H72988 [2]
KD Bolt

H71659 [2]
KD Cam

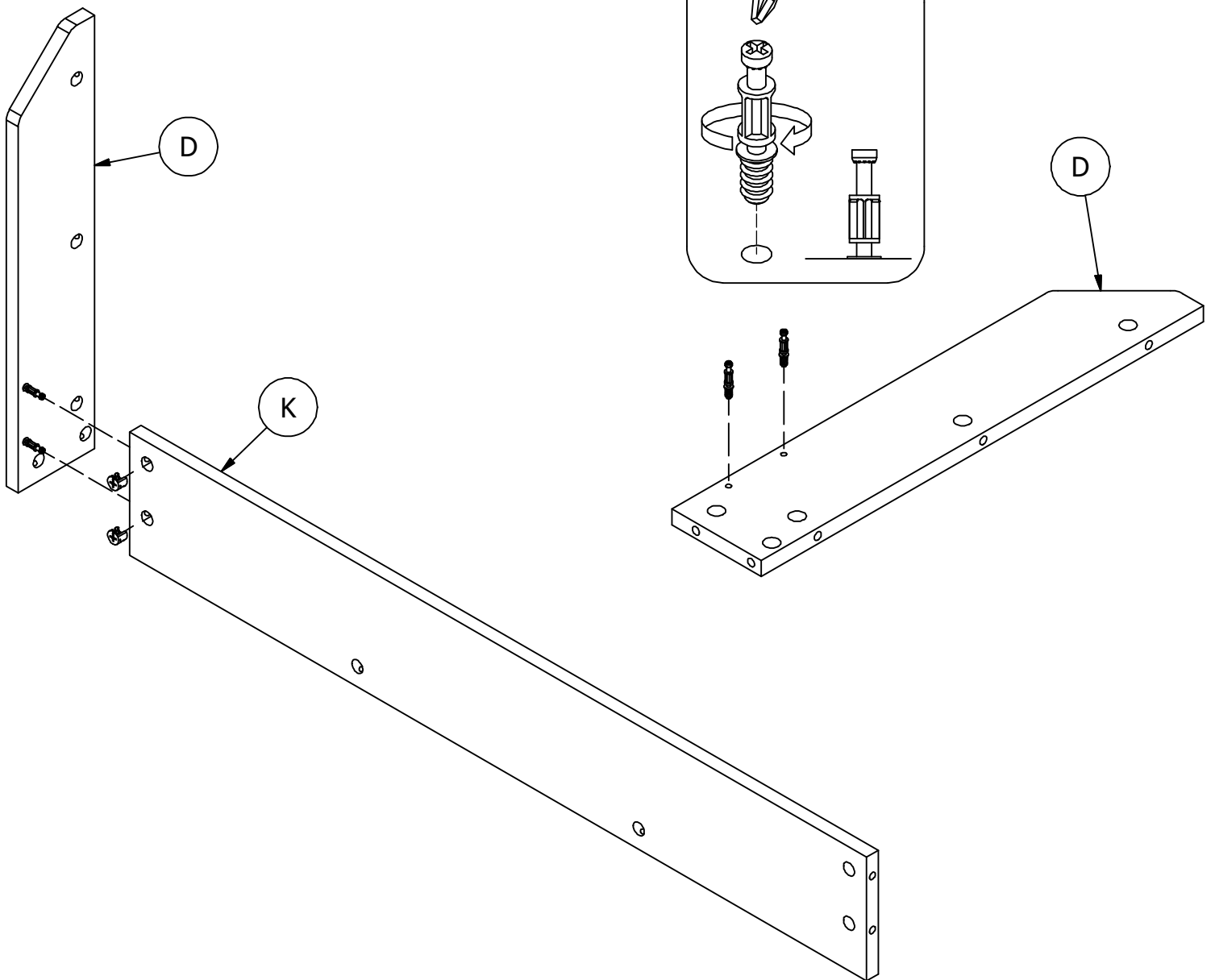
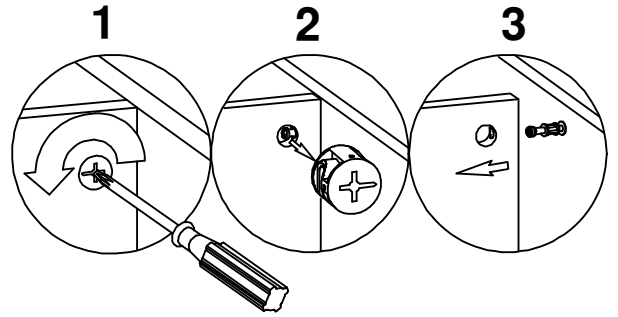

STEP 3

Prepare Panels

H72988

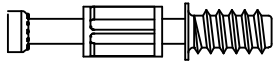

KD Bolt

[7]

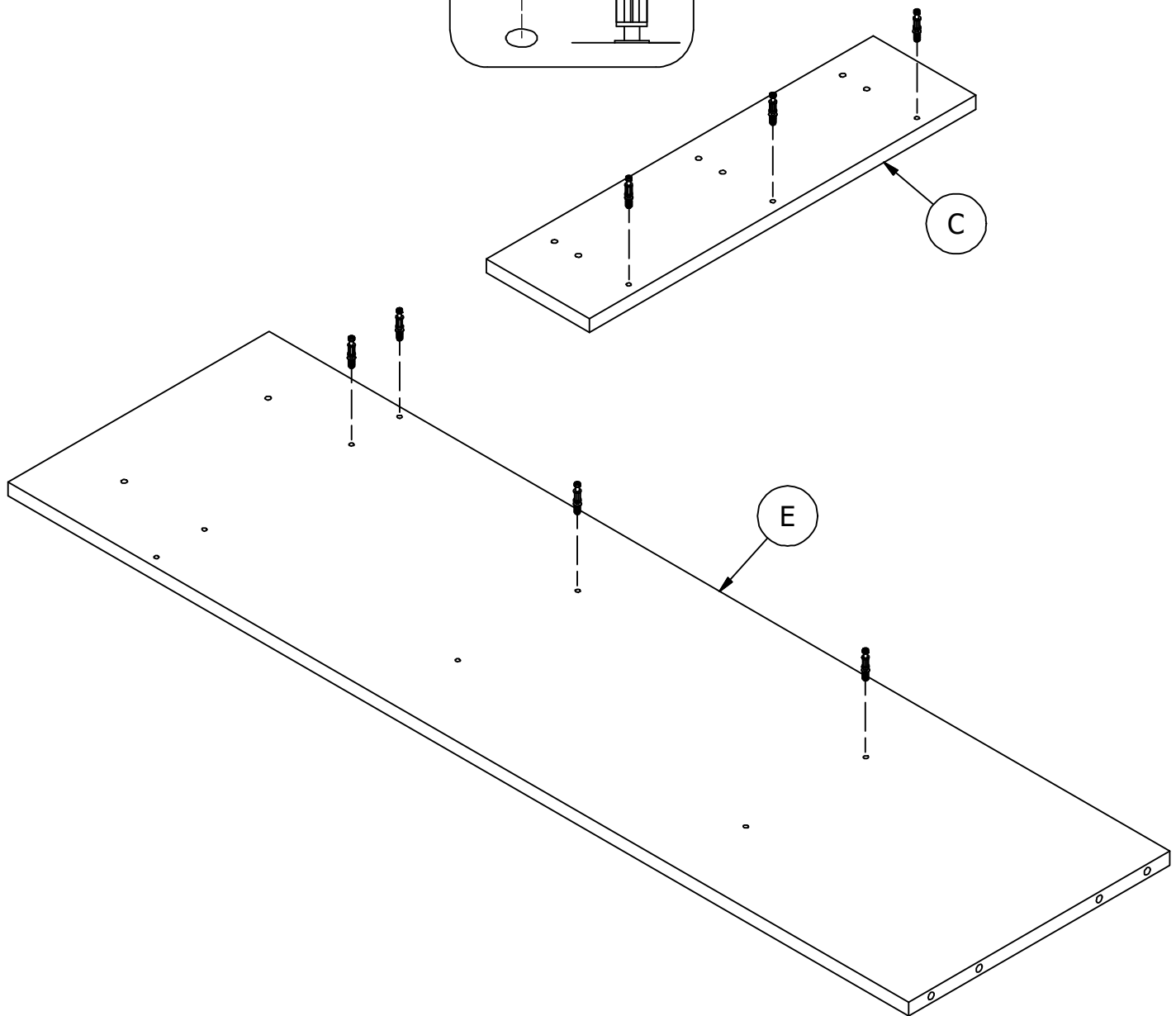
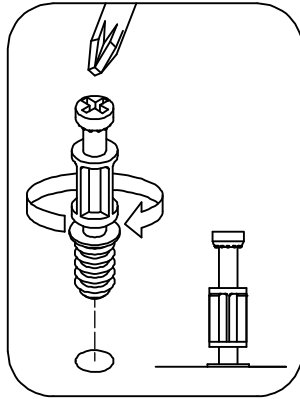

STEP 4

Assemble Side

H71659

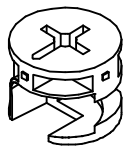

[4]

KD Cam

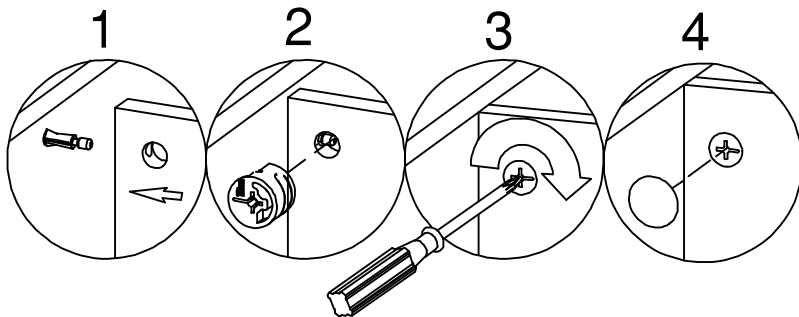

[4]

5mm

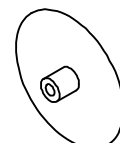

[2]

Cover Cap

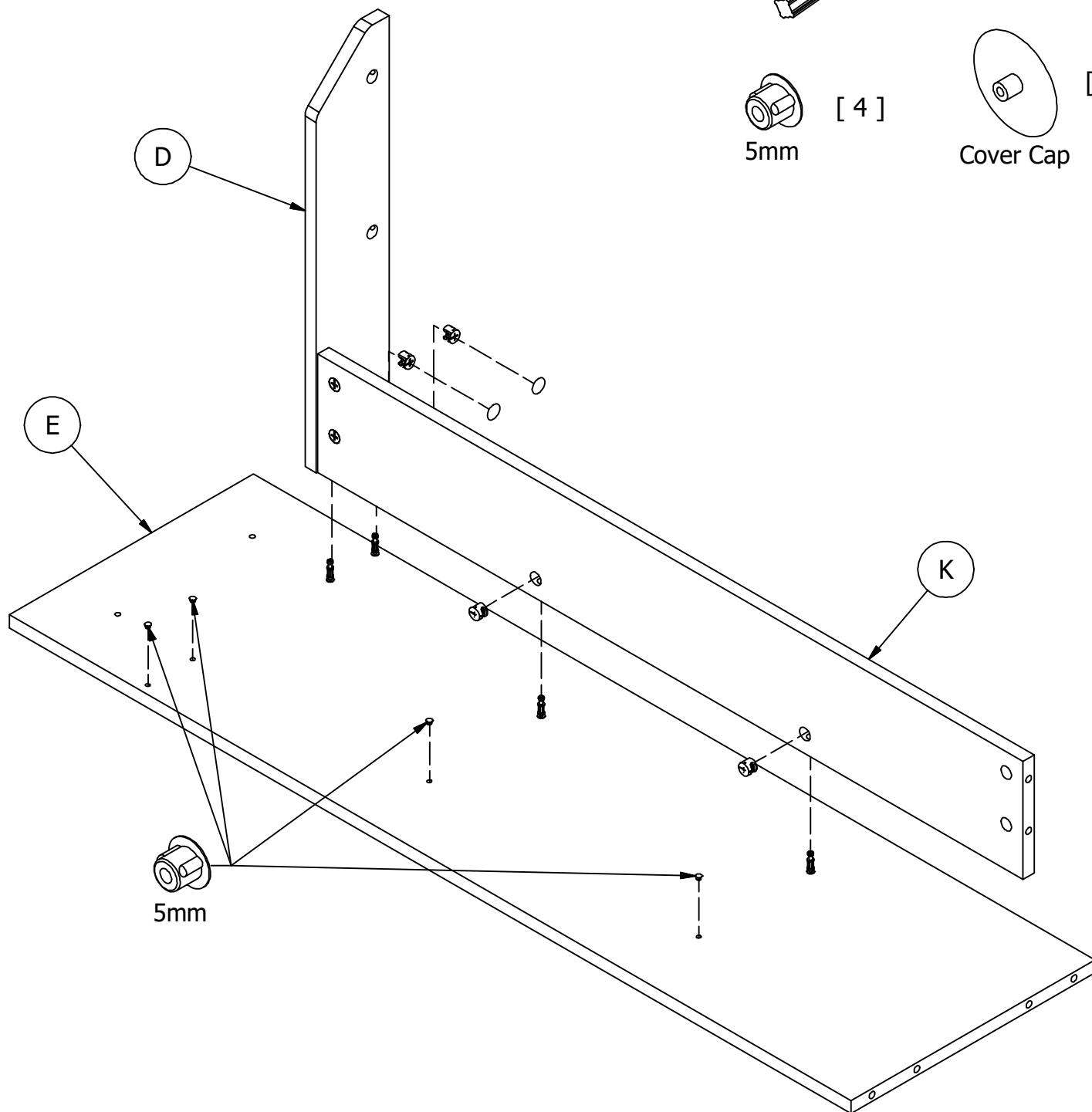

STEP 5

Assemble Side

Scan QR Code to Watch Video on:



How to Tighten KD Cams

H71659

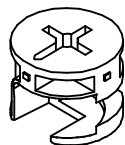

KD Cam

[3]



[3]

Cover Cap

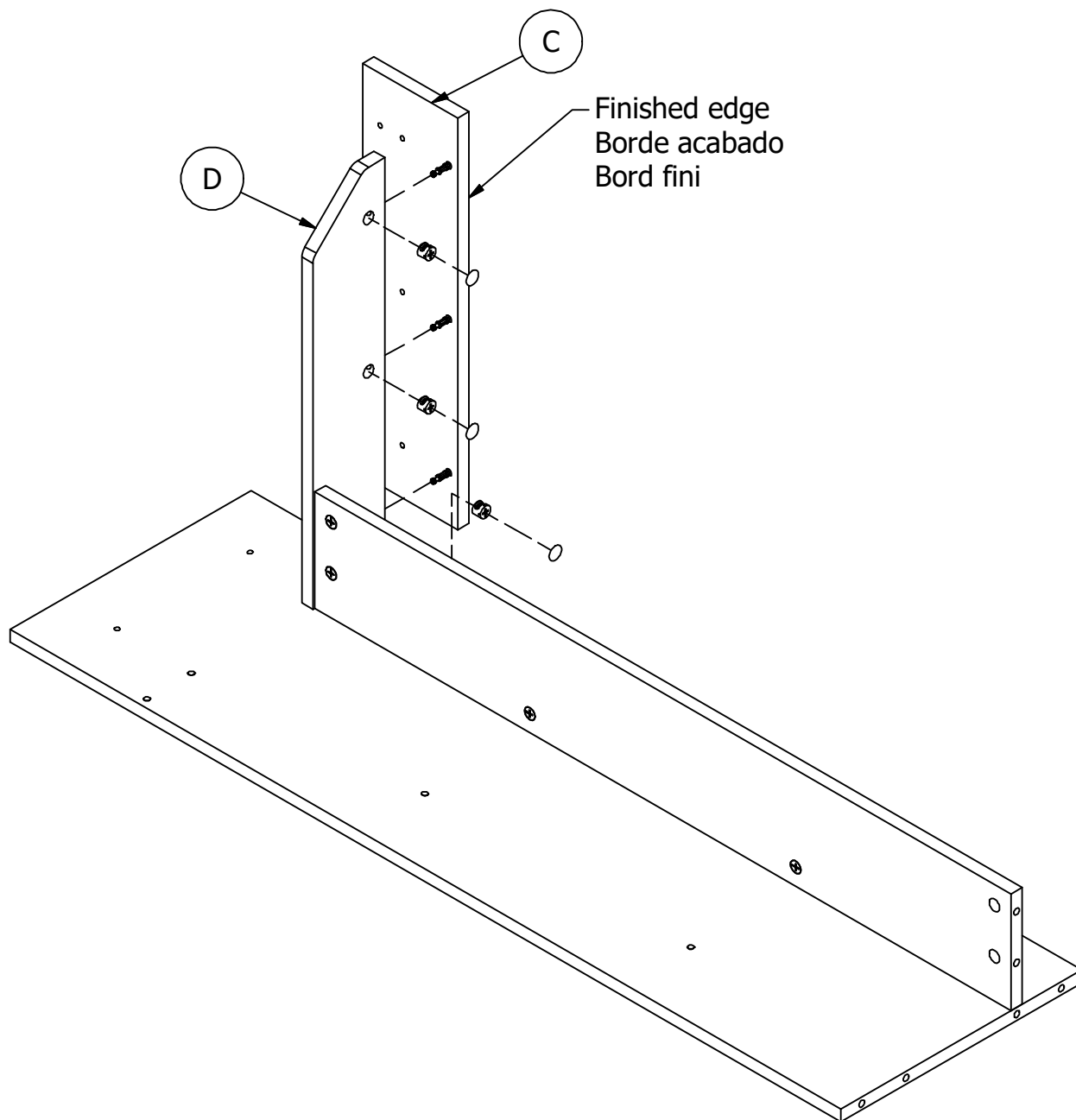
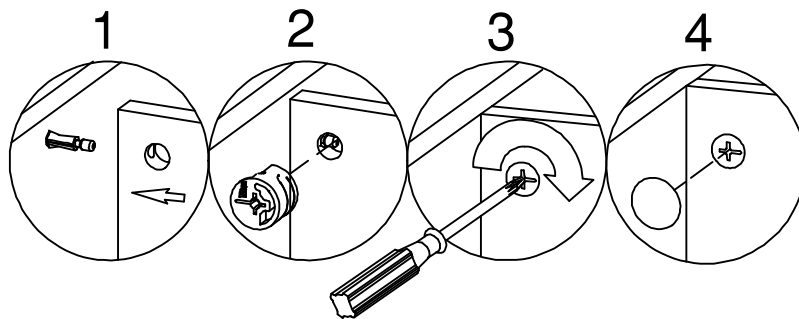

STEP 6

Assembly Base

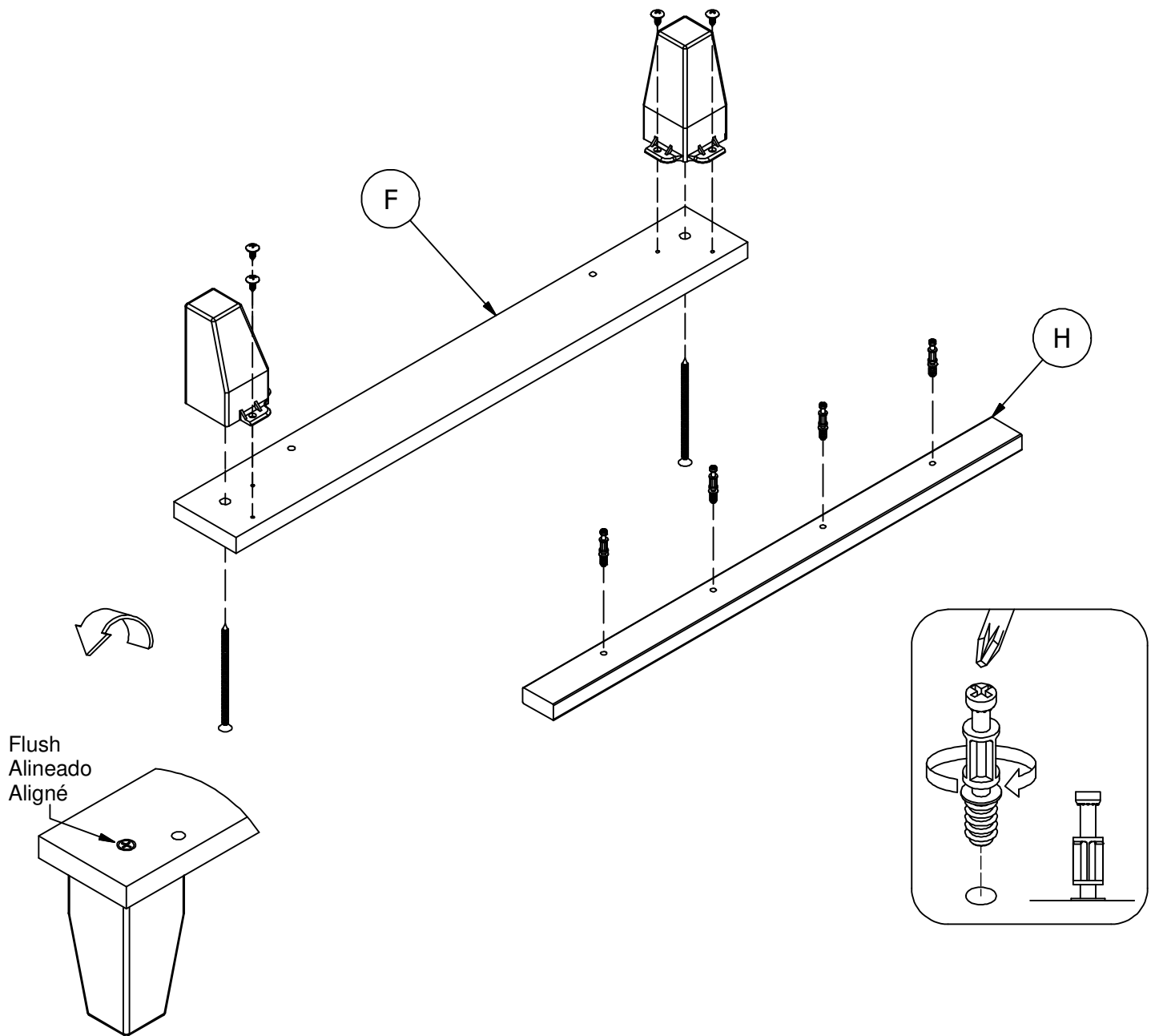
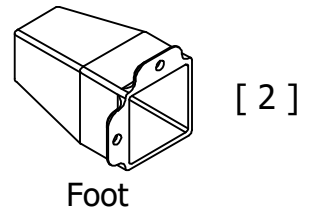
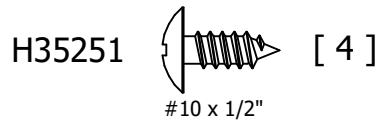
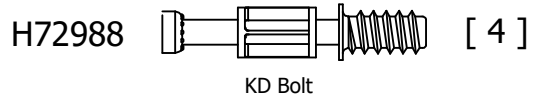
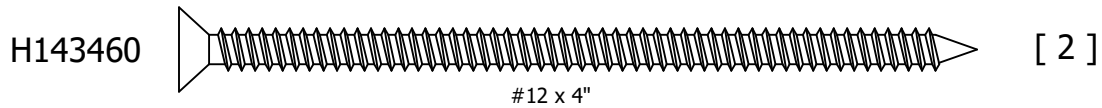

STEP 7

Prepare Side

H72988

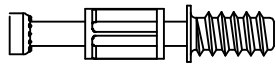

[6]

KD Bolt

H38169

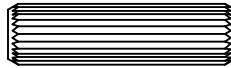

[6]

Wood Dowel 8 x 30



[2]

5mm

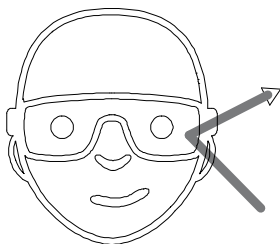
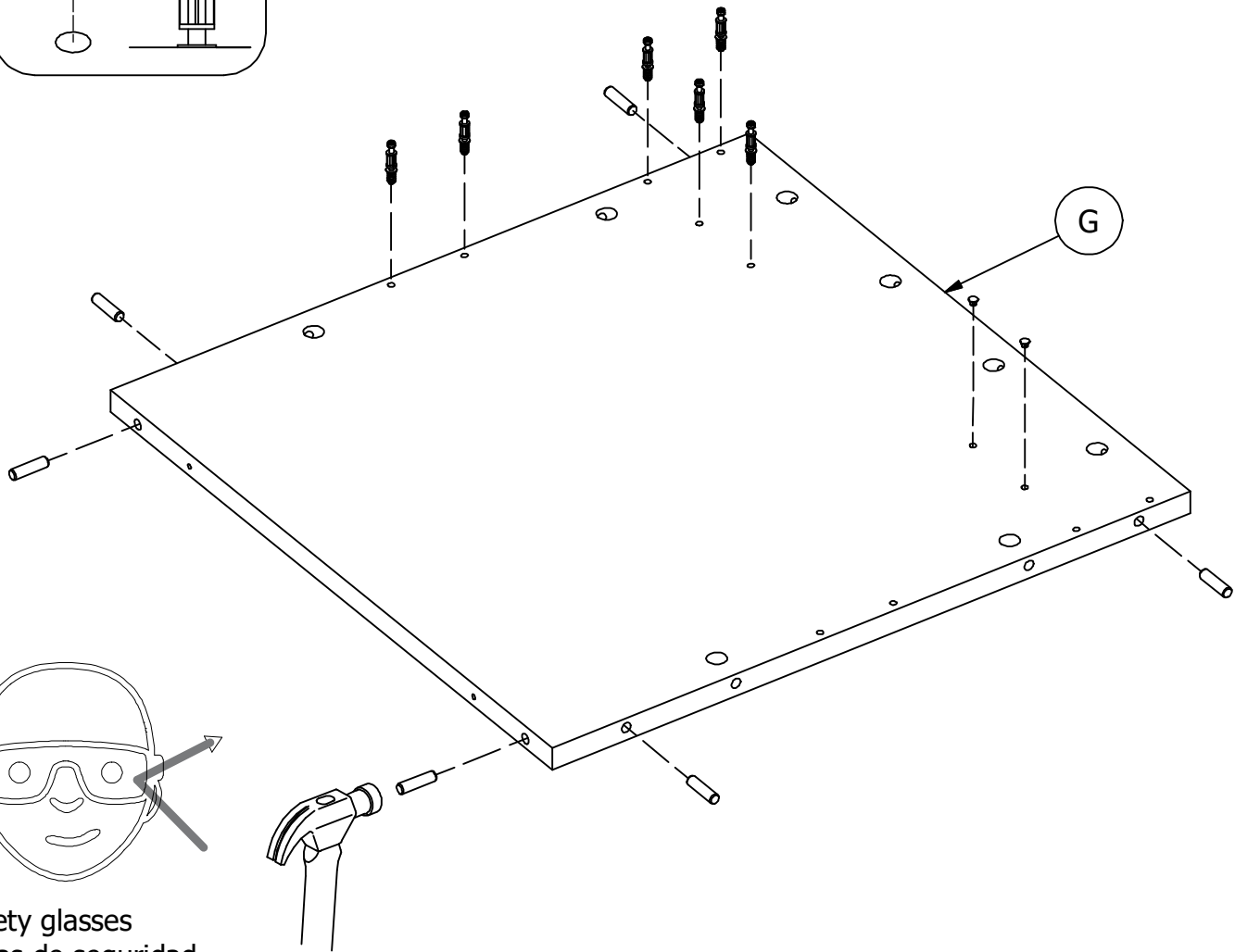
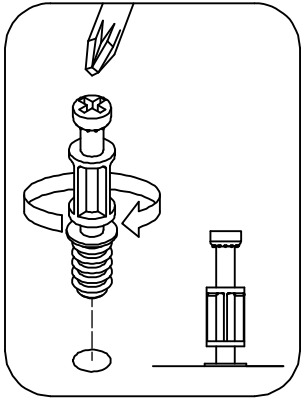

Safety glasses
Gafas de seguridad
Lunettes de protection

STEP 8

Assemble Leg

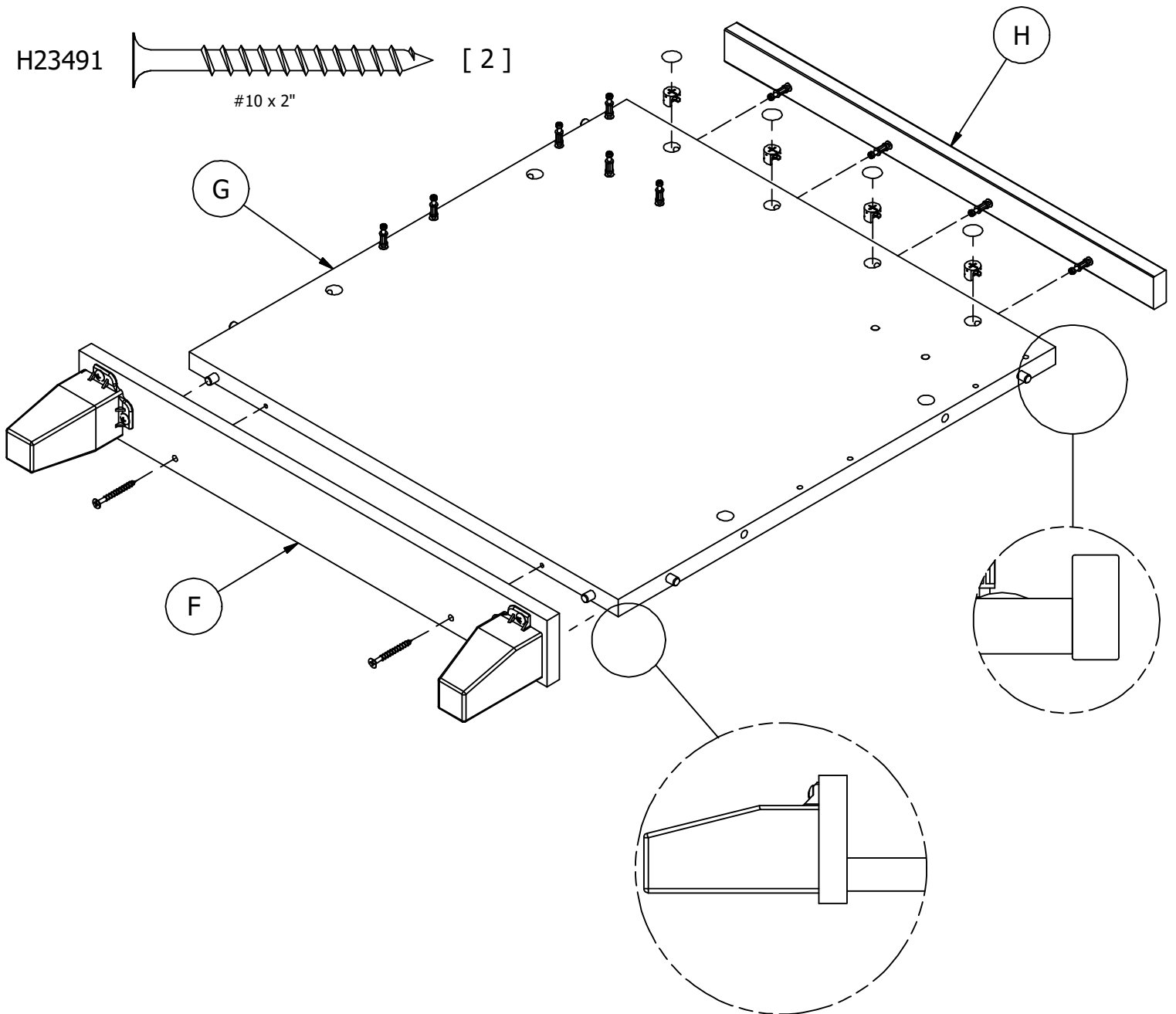
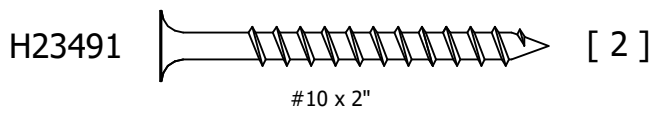
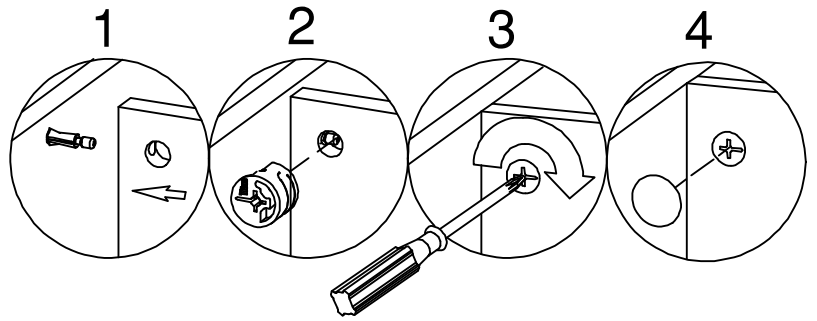
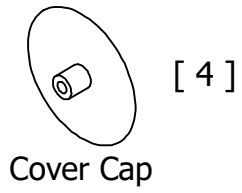
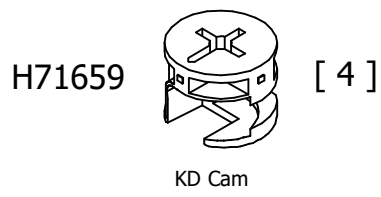

STEP 9

Prepare Rails

H72988

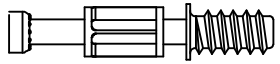

[4]

KD Bolt

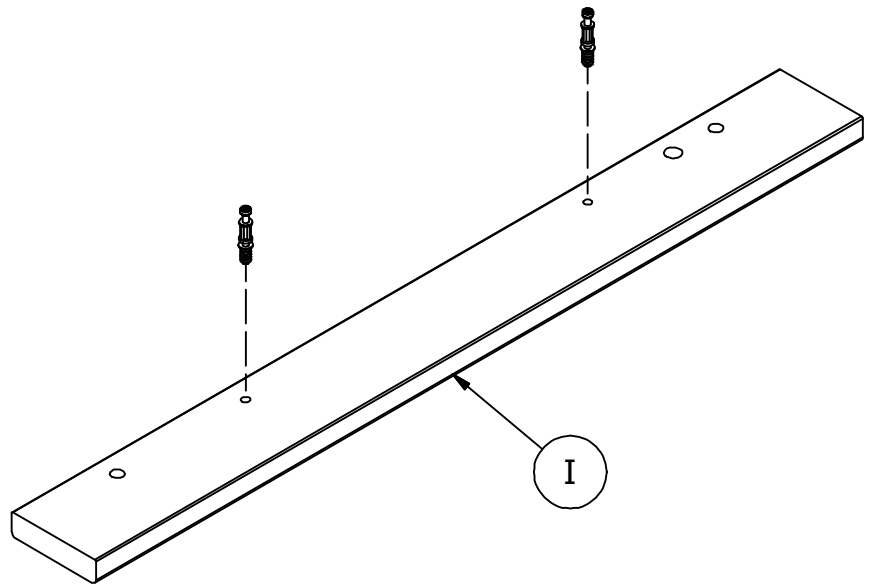
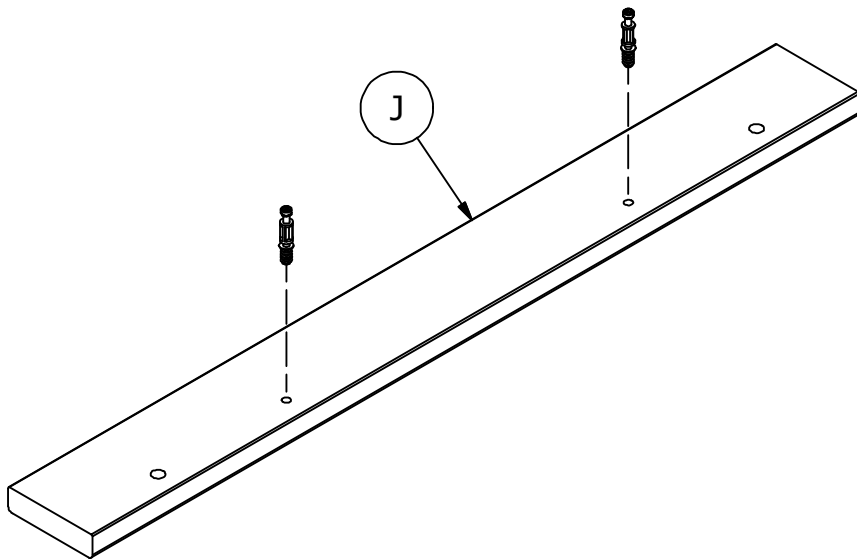
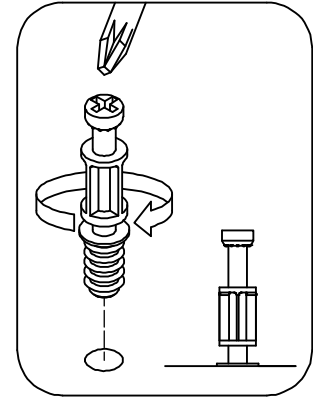

STEP 10

Assemble Modesty Panel

H71659 [6]

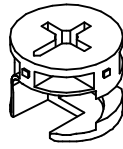

KD Cam

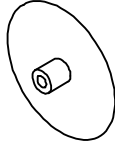

[2]

Cover Cap

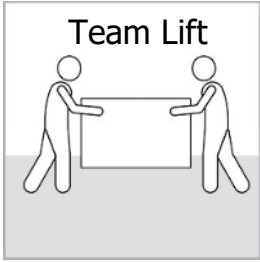
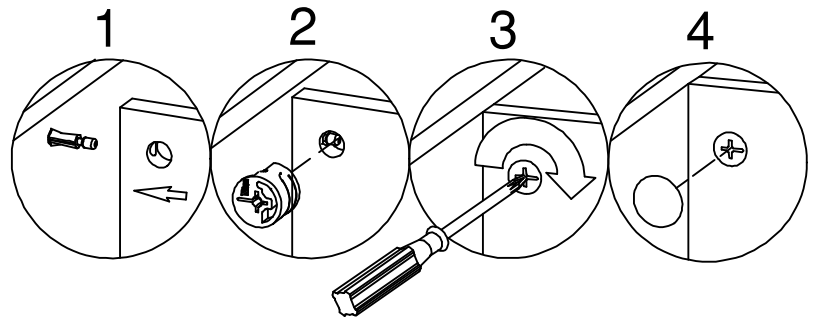

Team Lift

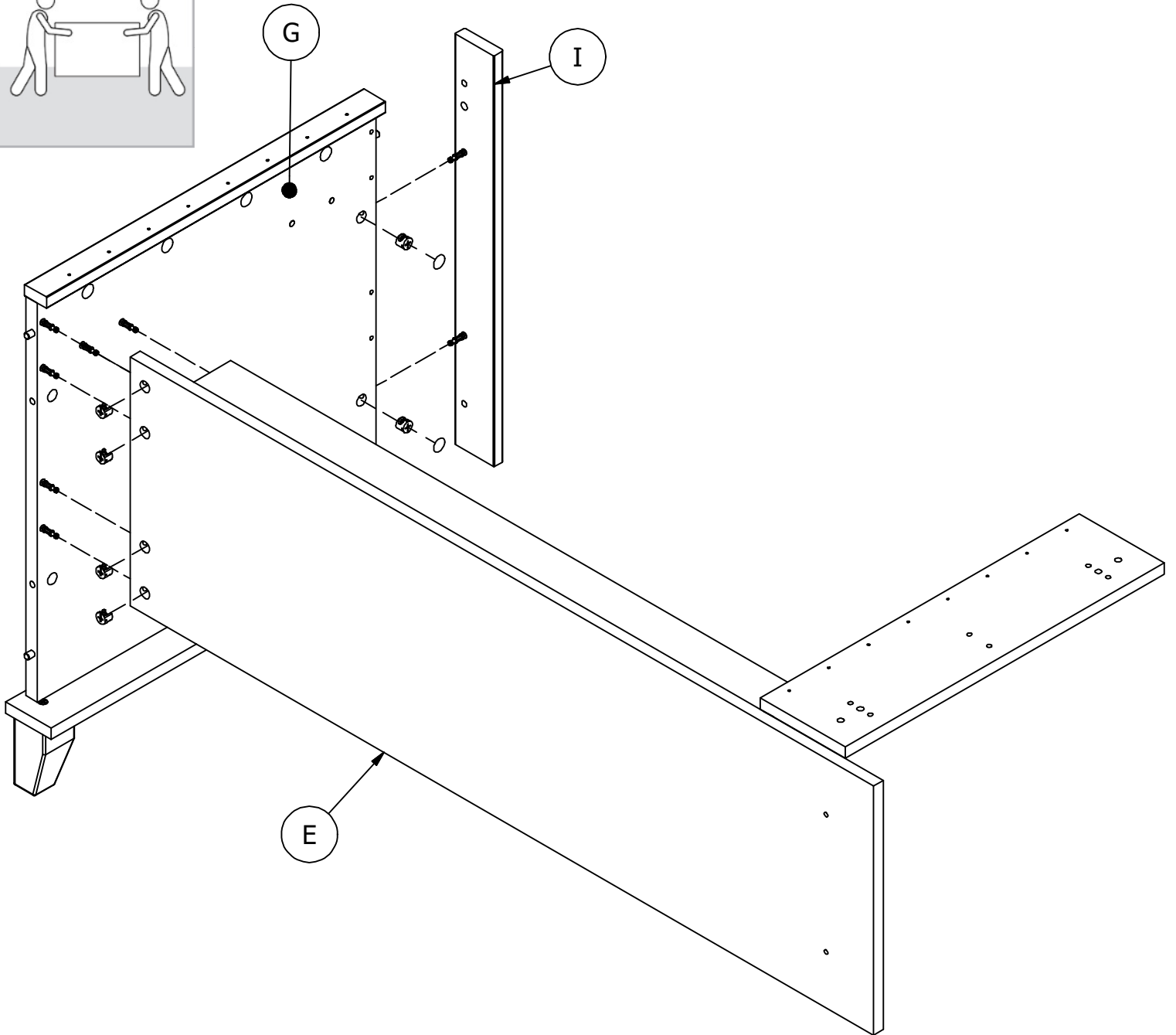

STEP 11

Assemble Modesty Panel

H71659

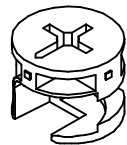

KD Cam

[4]

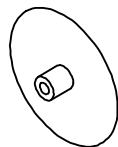

Cover Cap

[2]

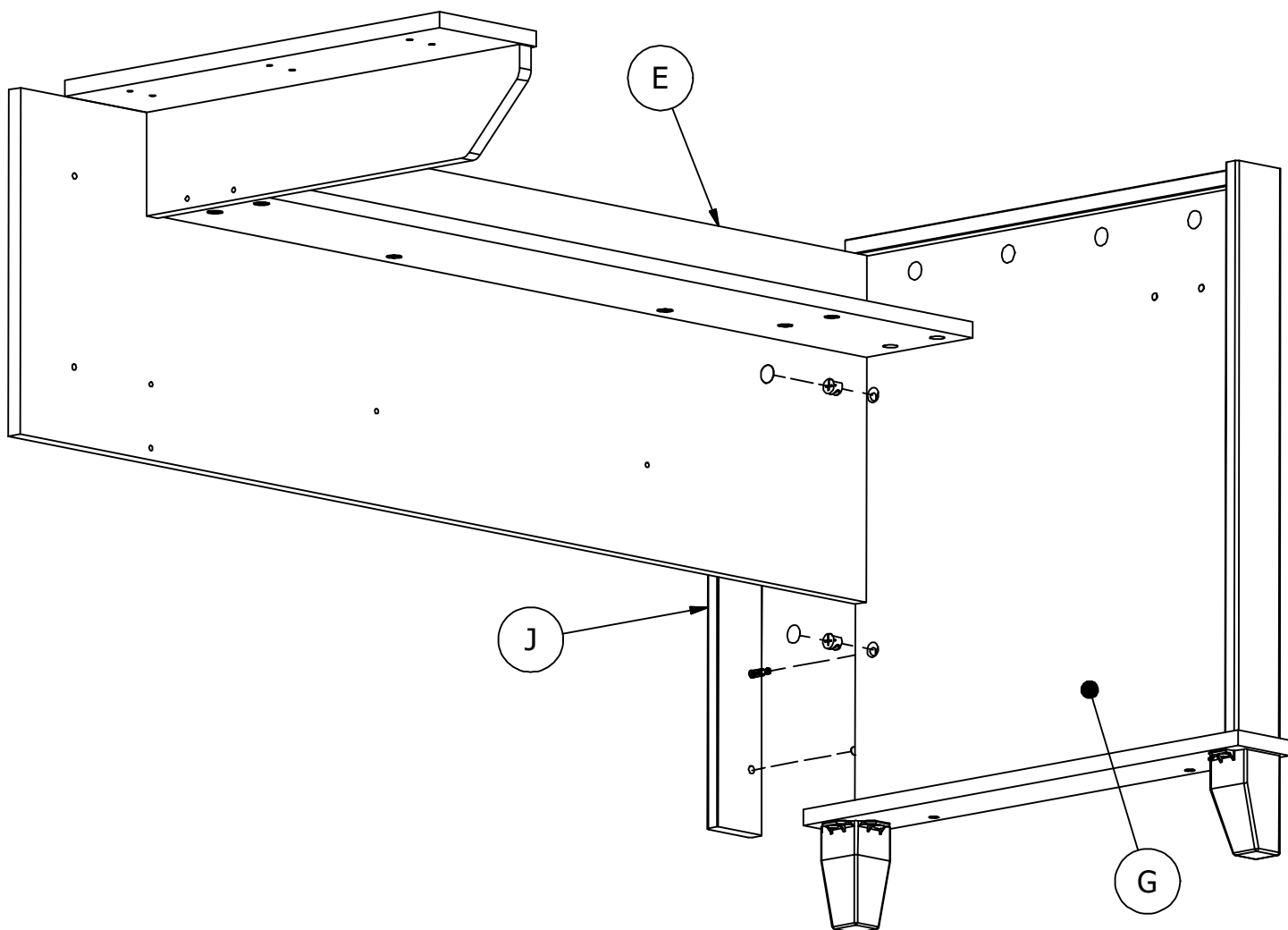
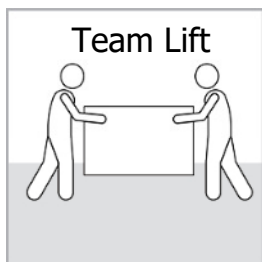
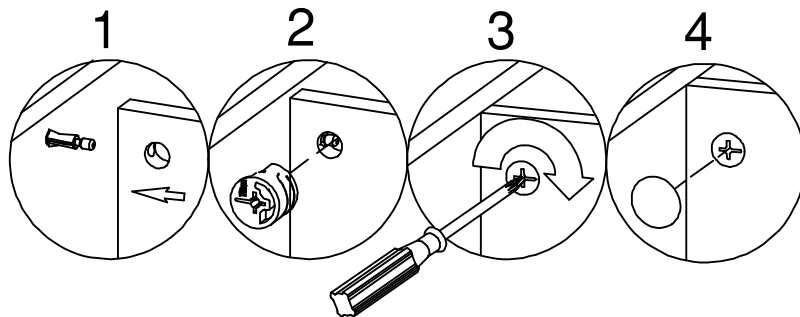

STEP 12

Remove Rail

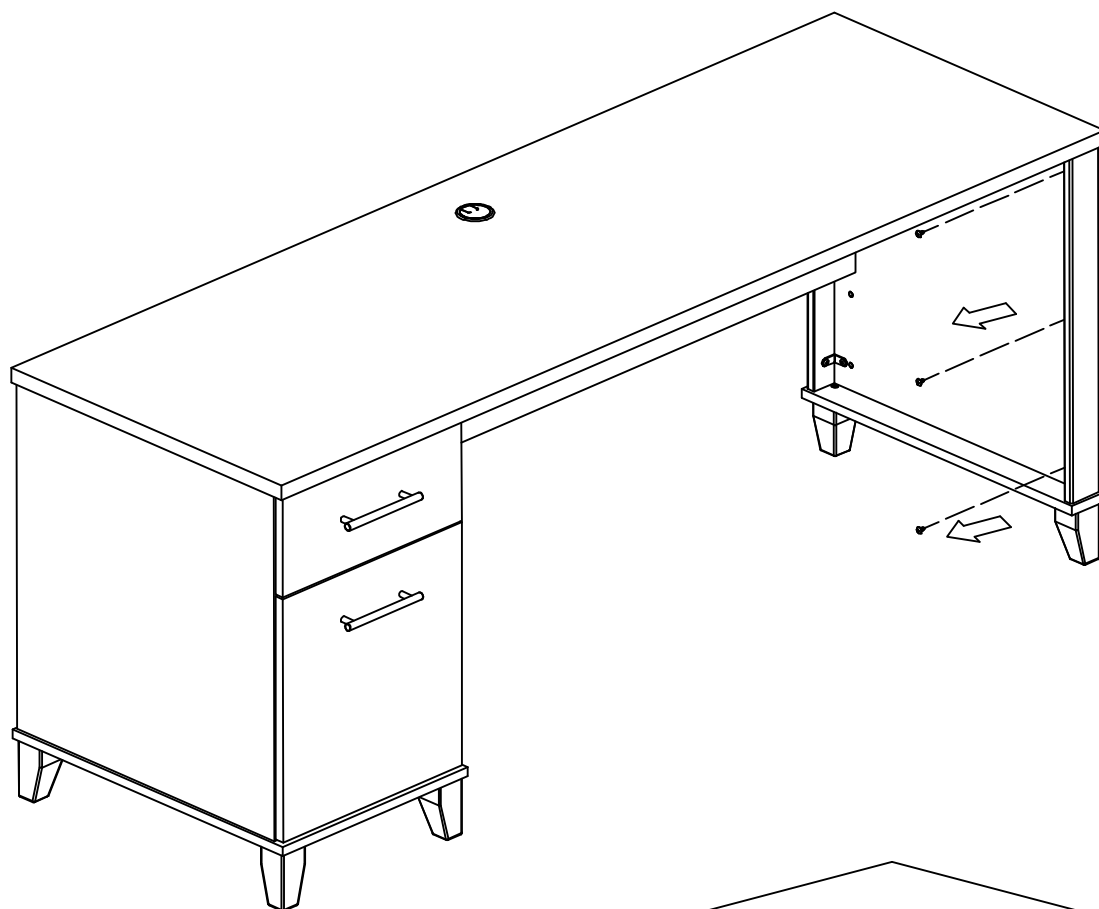

Remove & Discard
Eliminar y desechar
Supprimer et rejeter

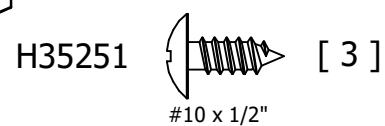

Remove & Discard
Eliminar y desechar
Supprimer et rejeter

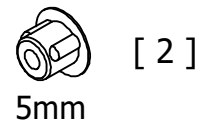
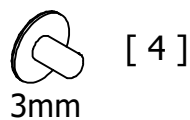

STEP 13

Prepare Rail

H38169  [2]
Wood Dowel 8 x 30

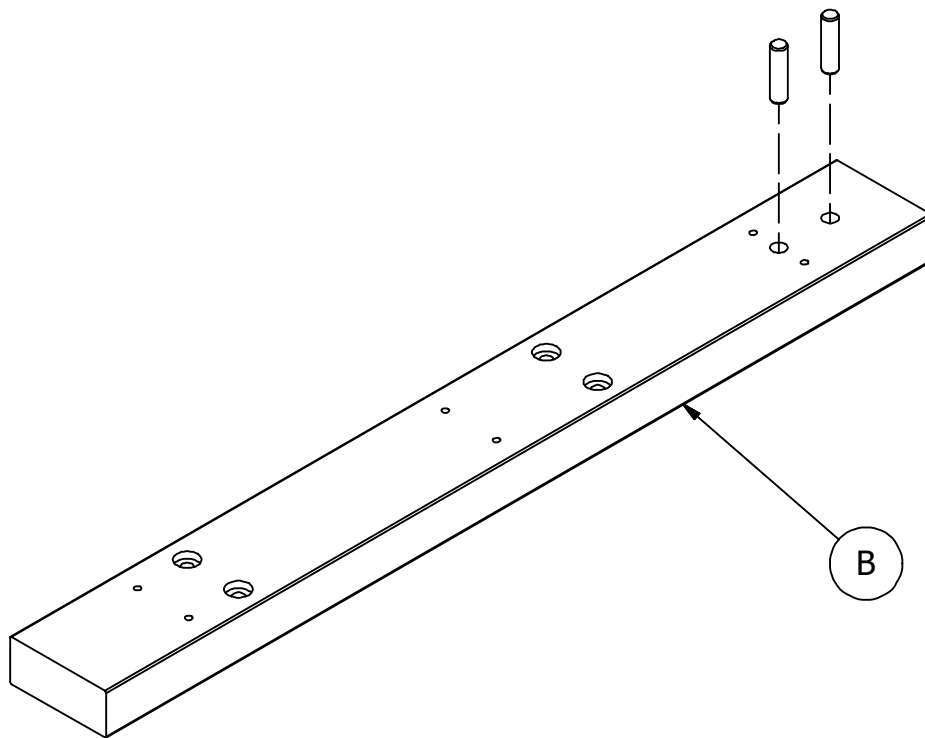

STEP 14

Attach Rail

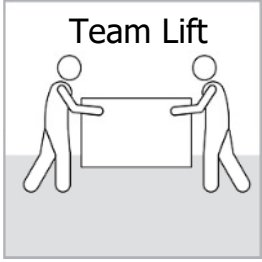

H23468

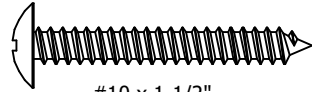

[4]

#10 x 1-1/2"

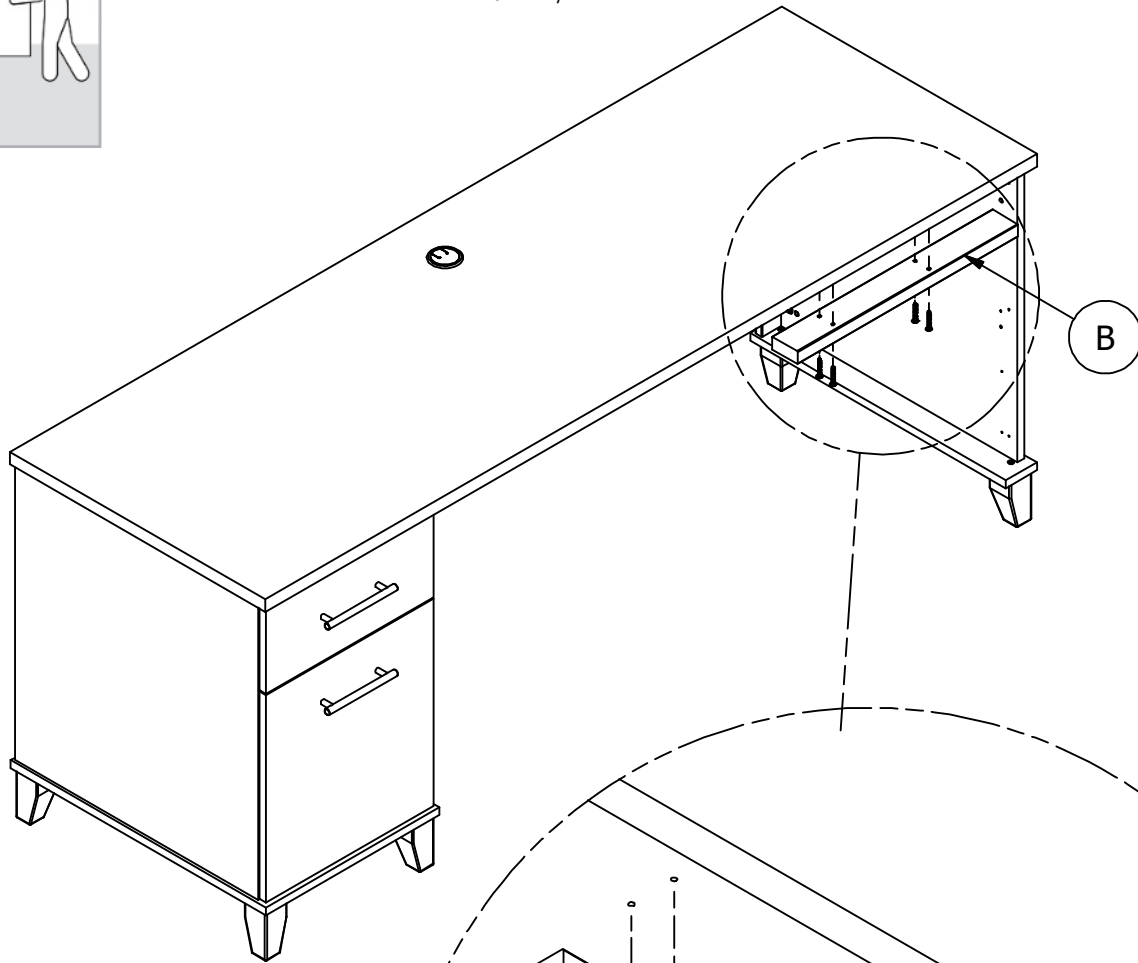

Assemble in final location.
Arme la unidad en el lugar destinado.
Assemblez en position finale

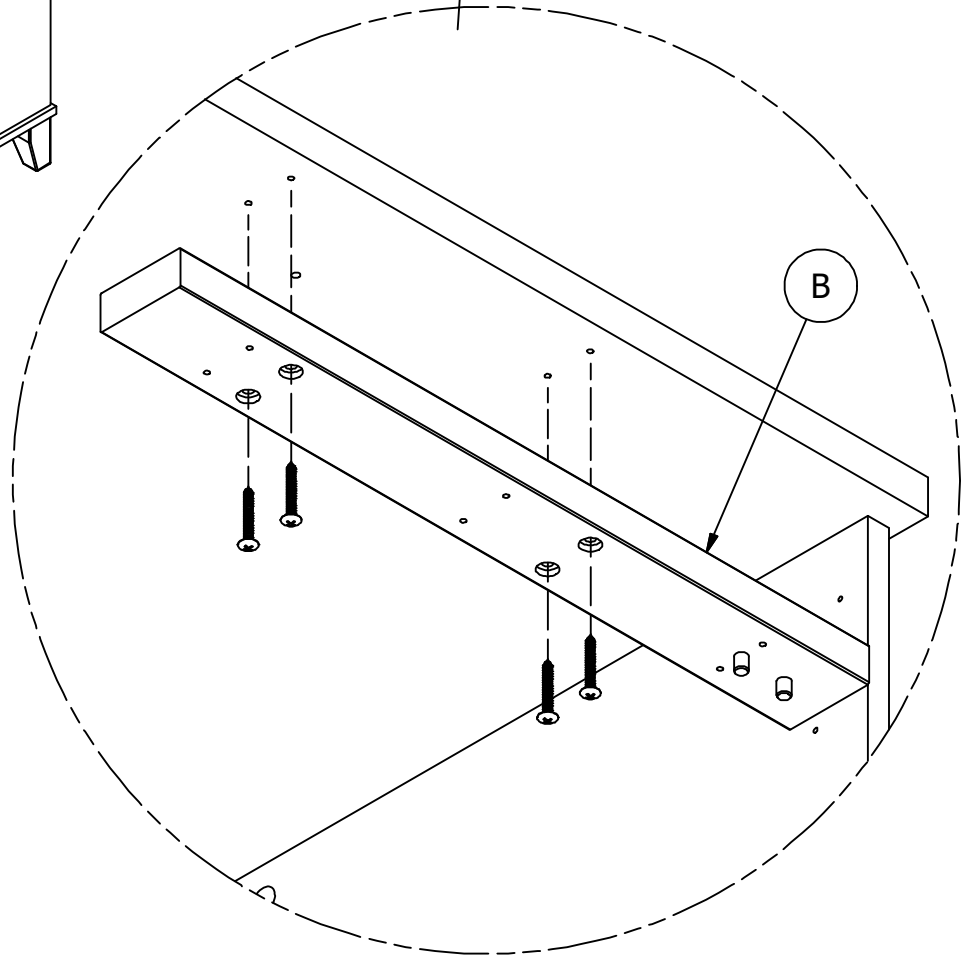

STEP 15

Assemble Panel

Team Lift

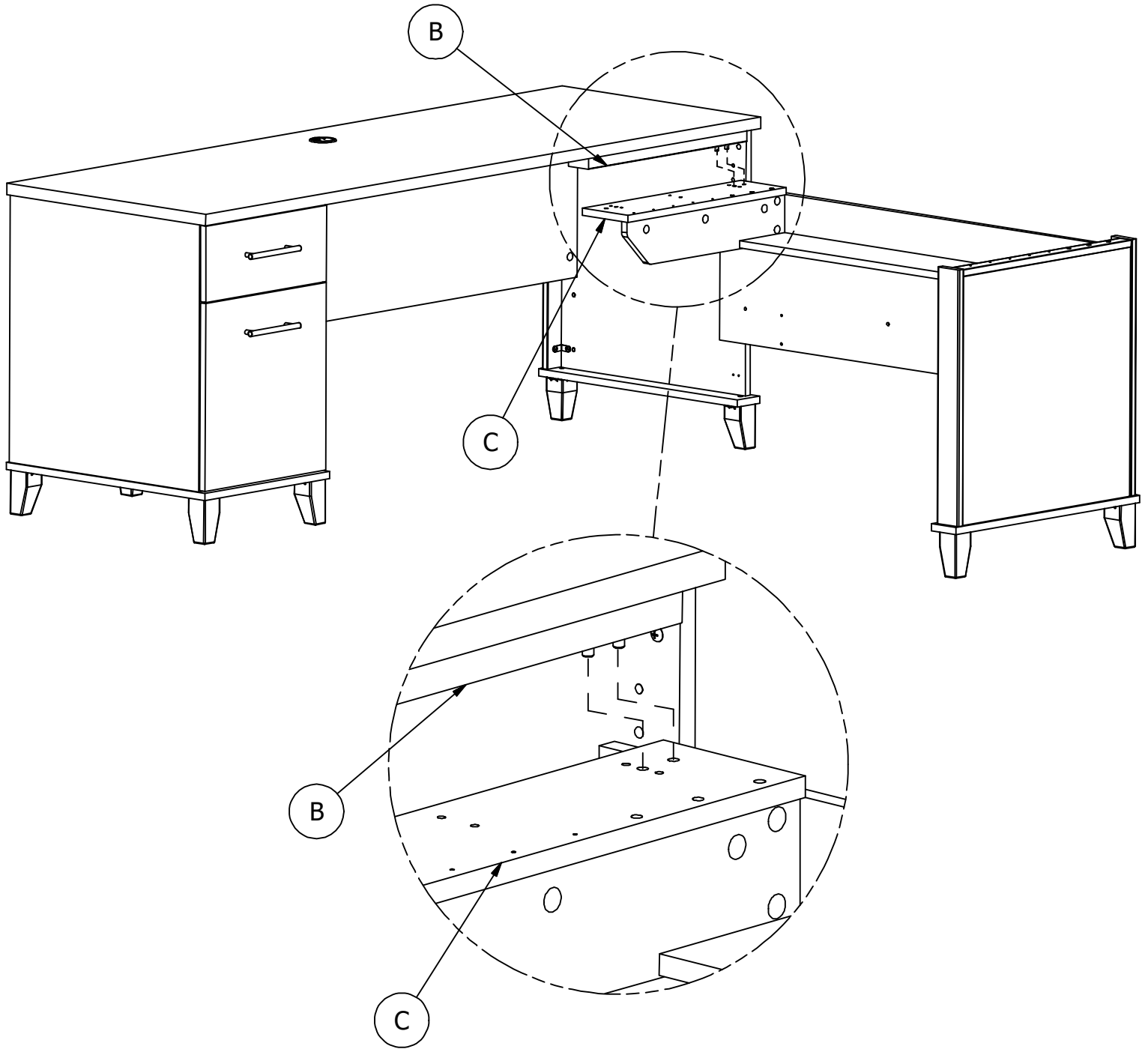
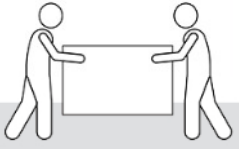

STEP 16

Assemble Panel

H23682  [2]
#10 x 1"

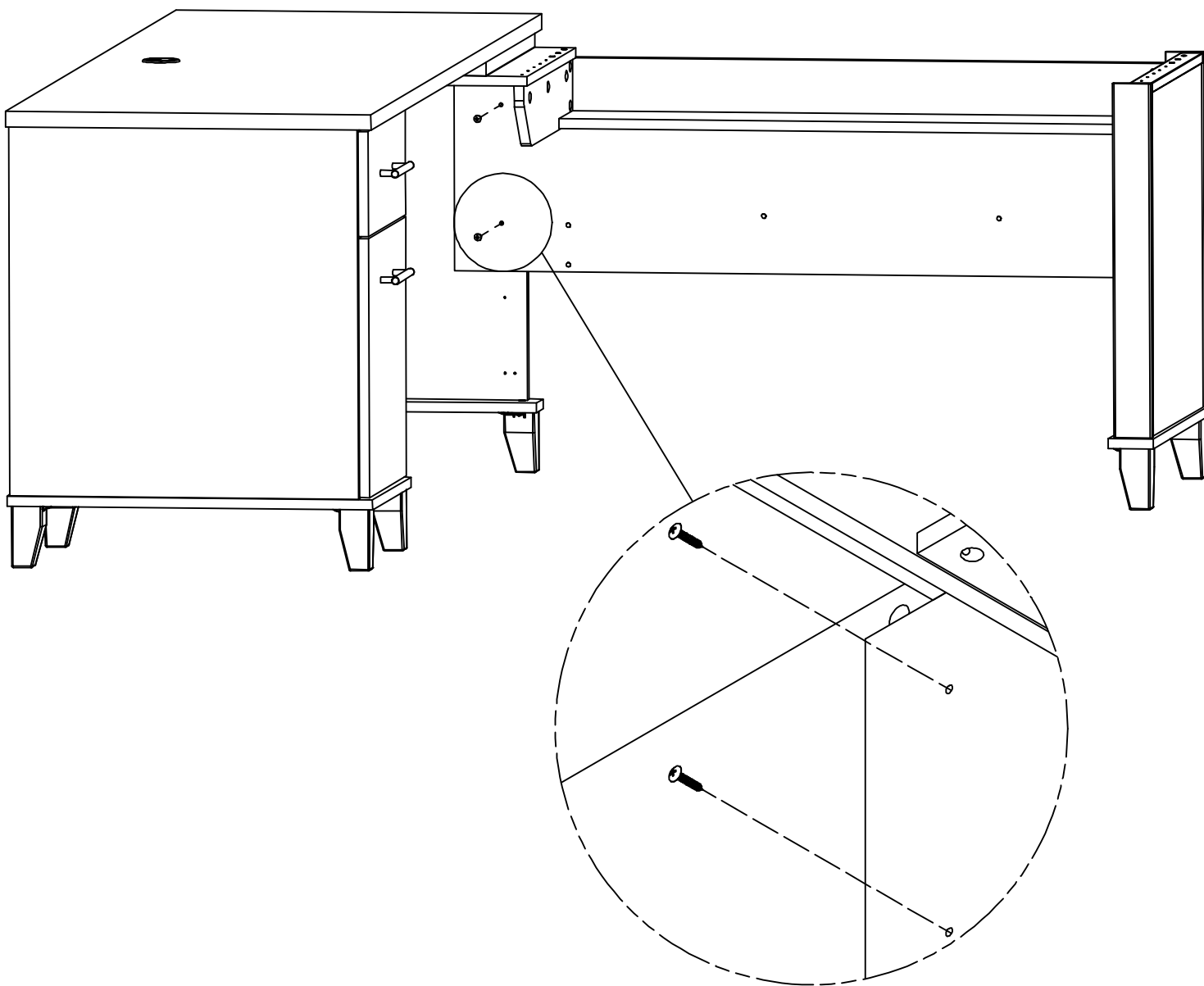
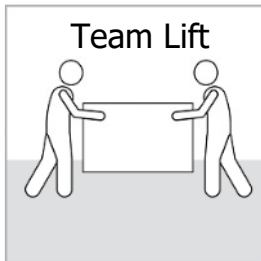

STEP 17

Assemble Panel

H23468

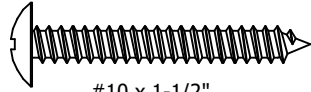

[6]

#10 x 1-1/2"

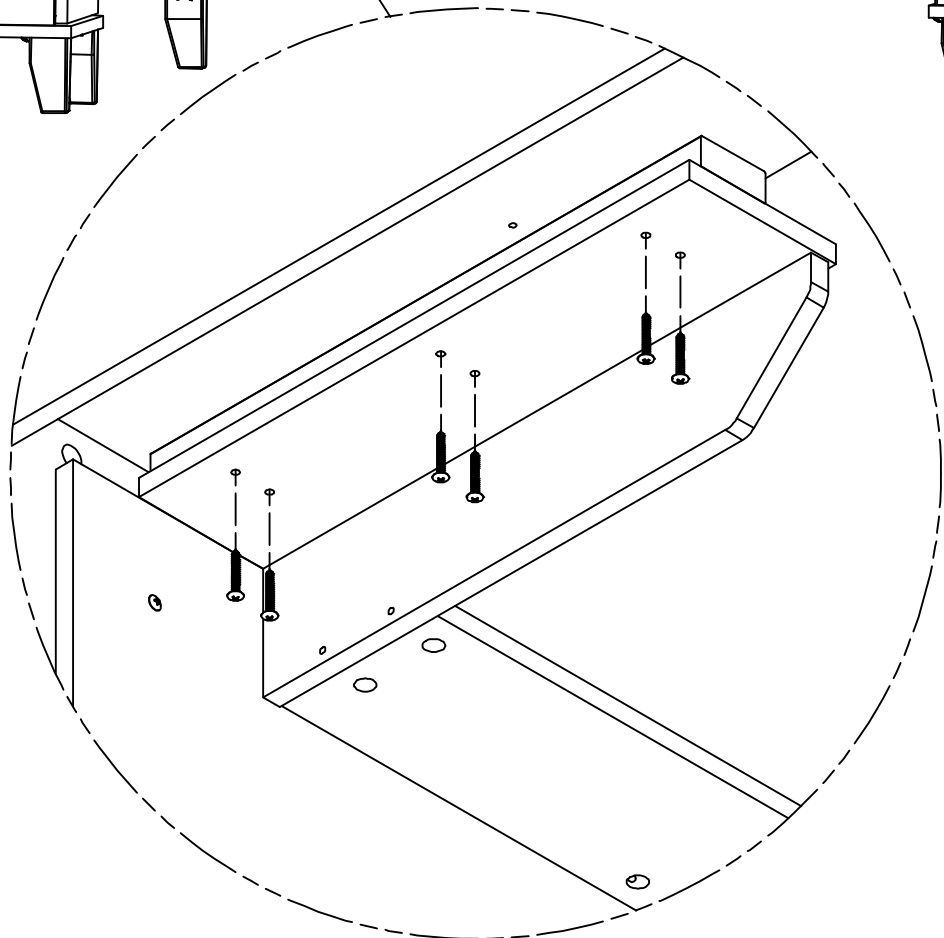
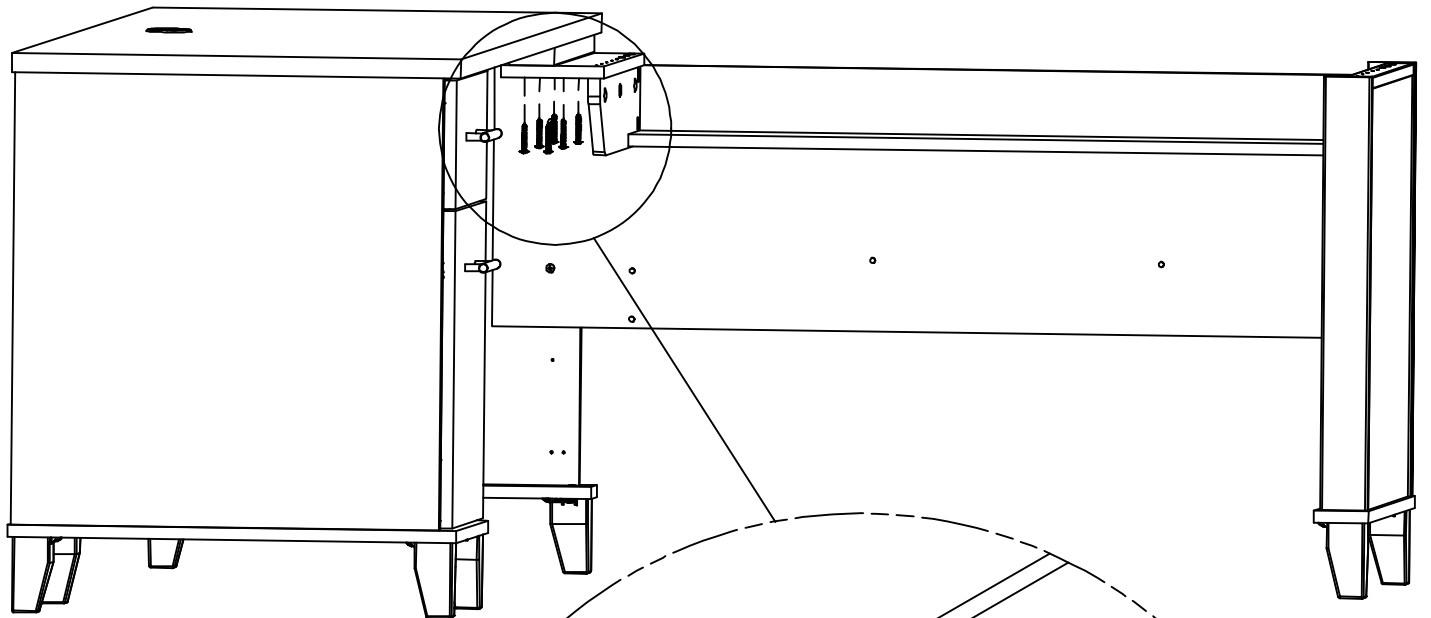

STEP 18

Assemble Rail

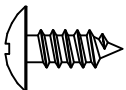
H35251  [4]
#10 x 1/2"

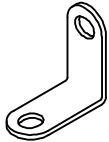
H67187  [2]
Angle Bracket

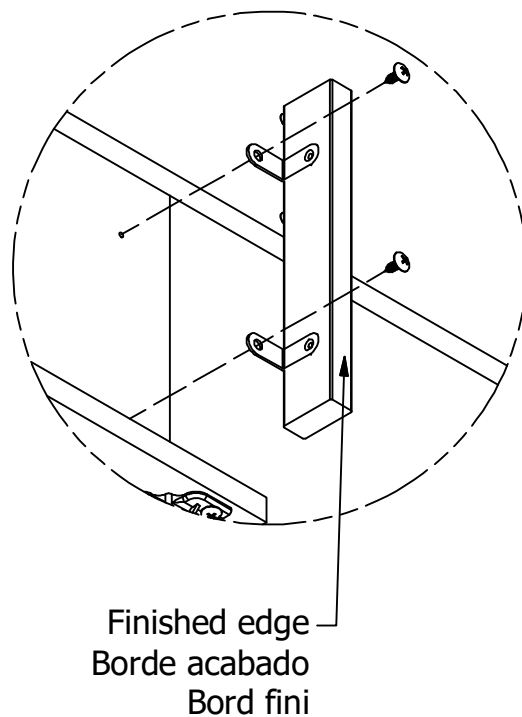
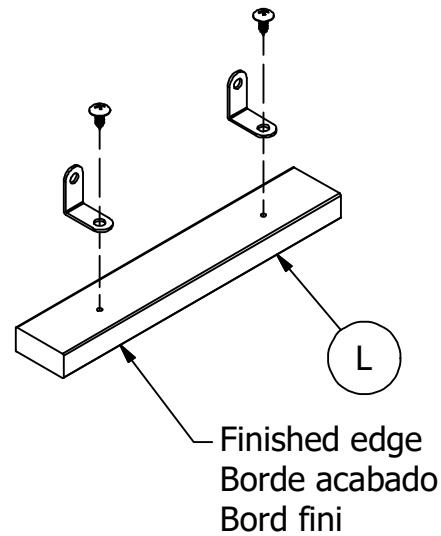
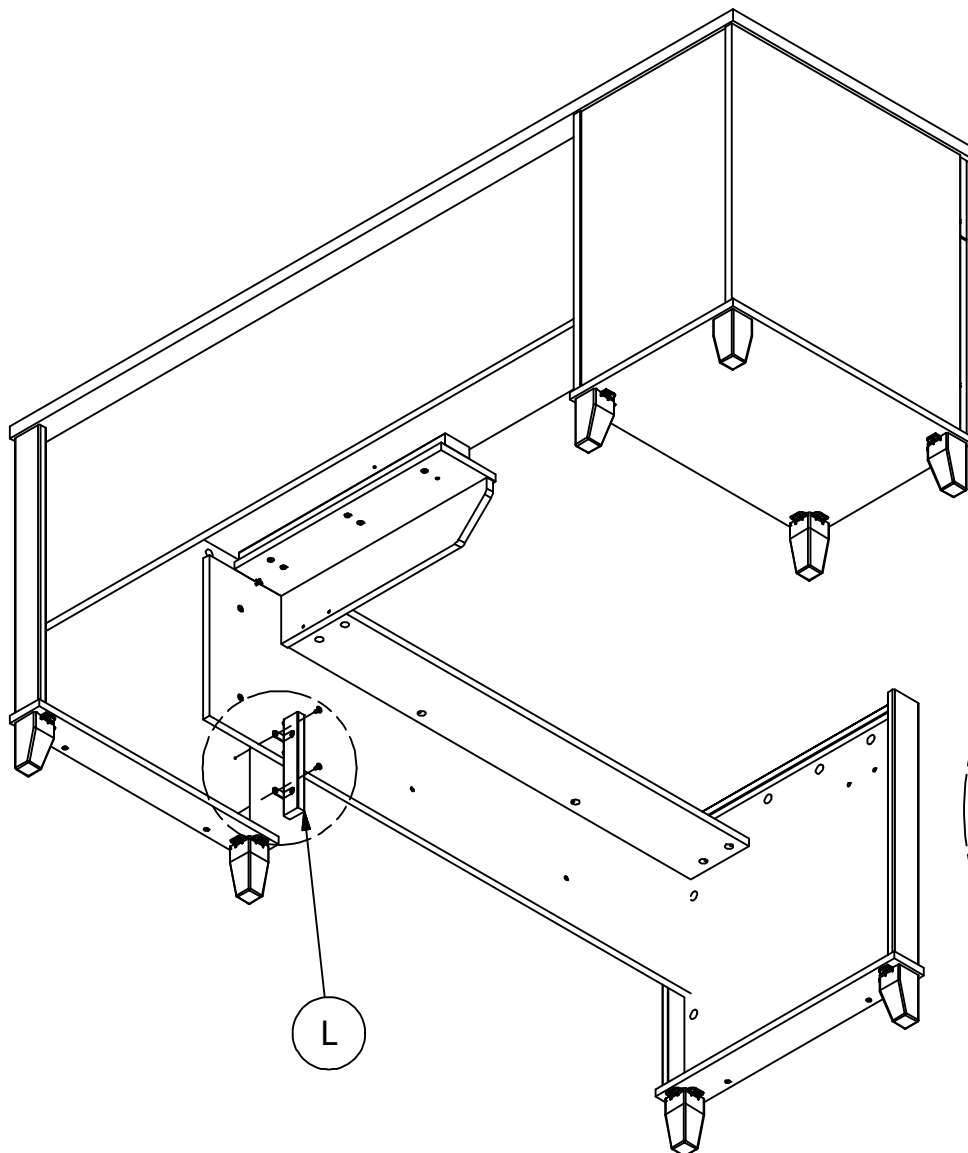

Go to Step 36.
Proceda al paso 36.
Allez à l'étape 36.

STEP 19

Assemble Rail

H71659

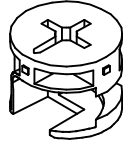

KD Cam

[2]

H72988

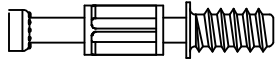

KD Bolt

[2]

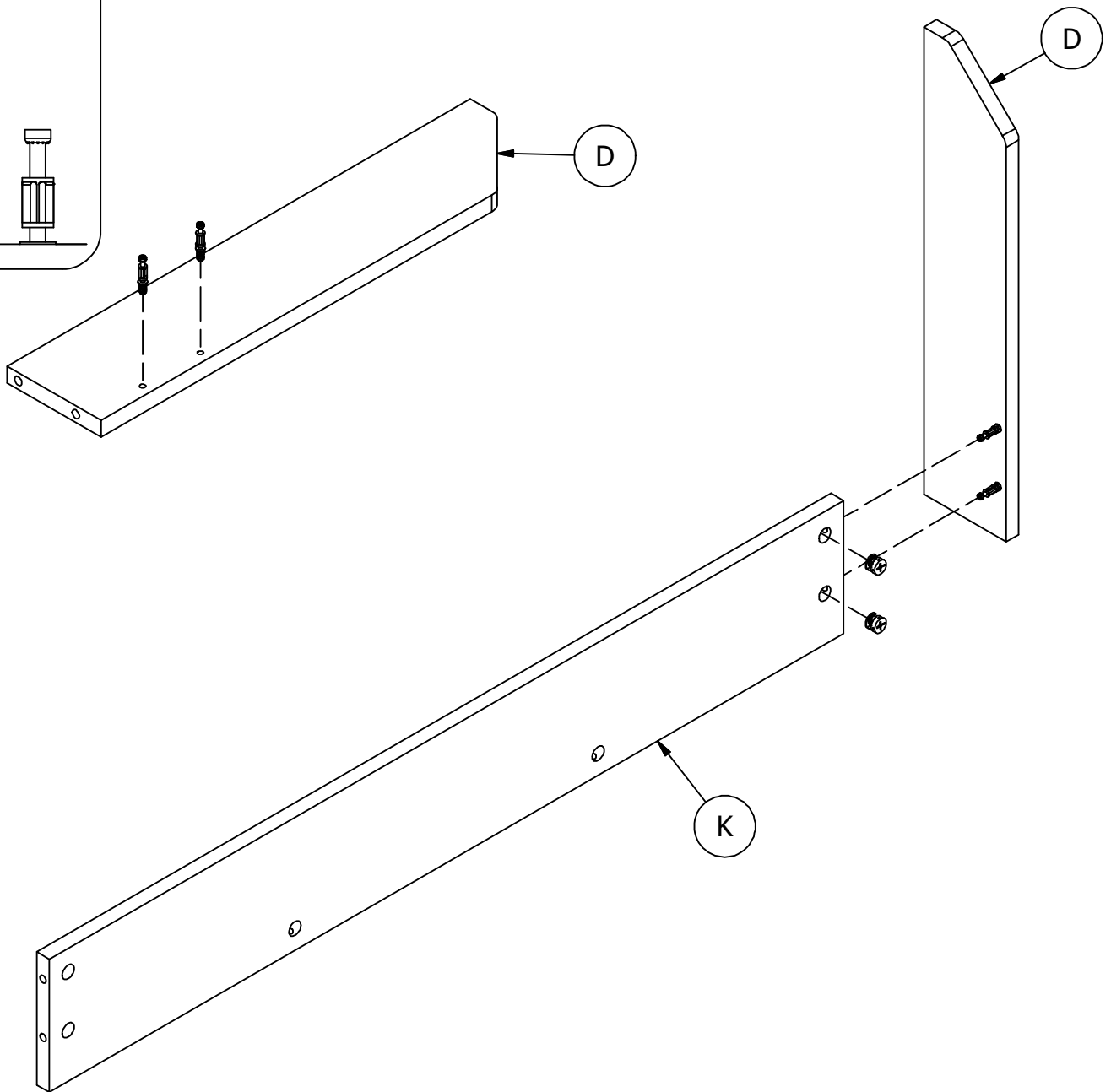
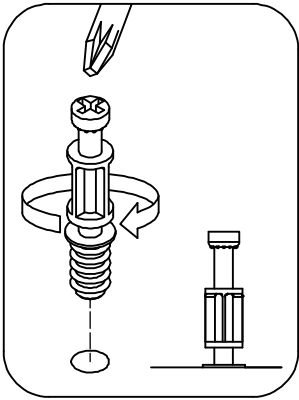
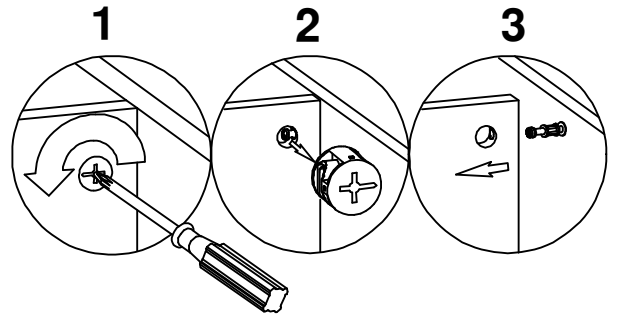

STEP 20

Prepare Panel

H72988 [7]
KD Bolt

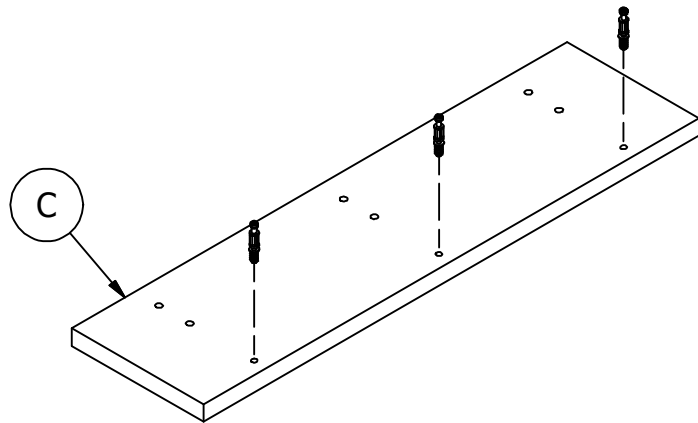
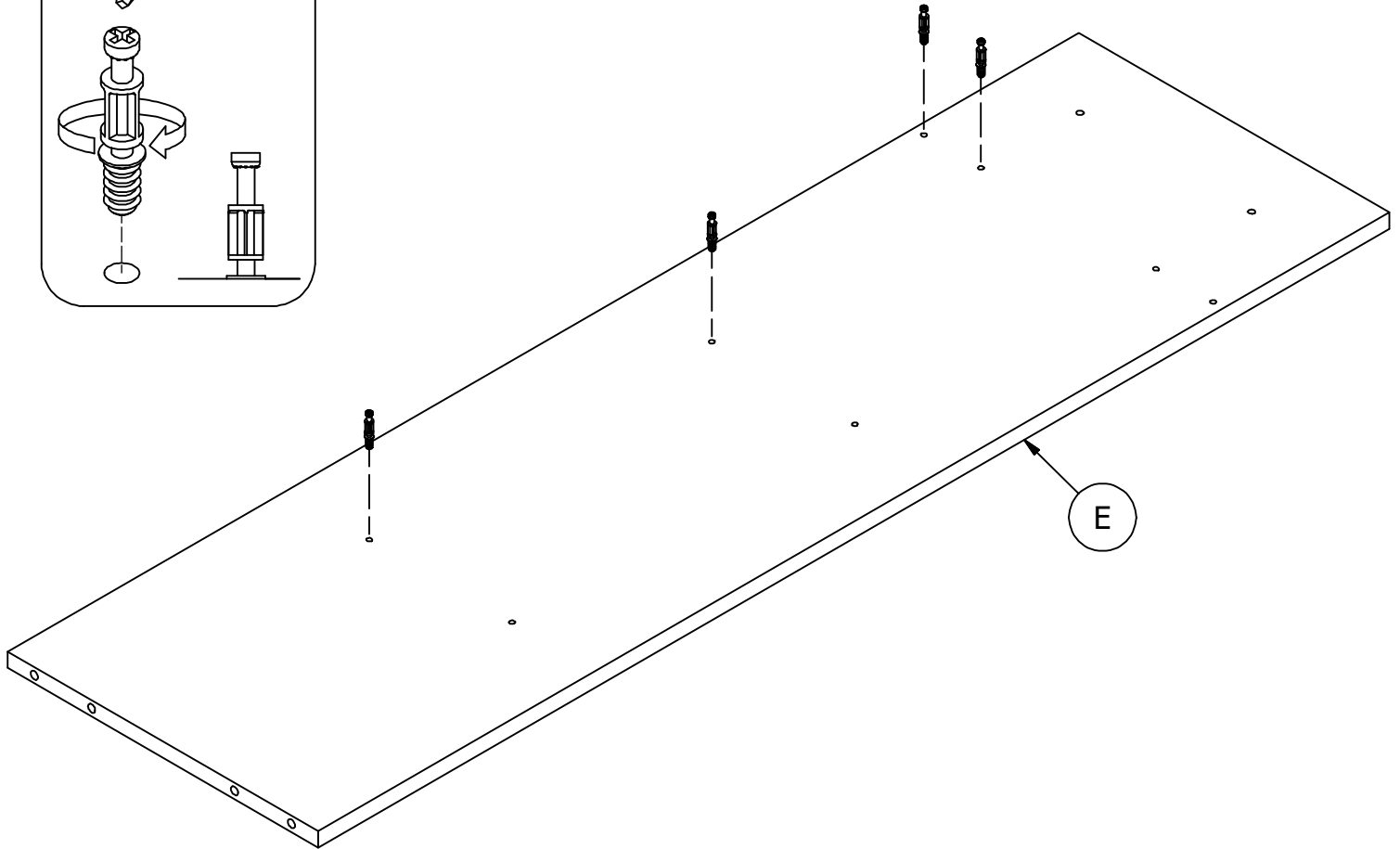
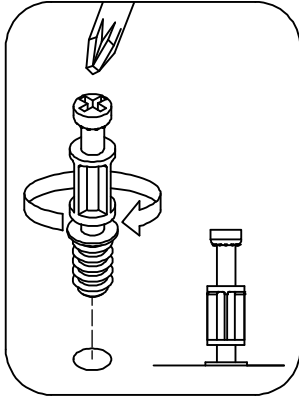

STEP 21

Assemble Panel

H71659

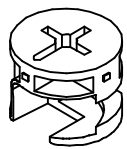

KD Cam

[4]

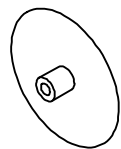

Cover Cap

[2]



5mm

[4]

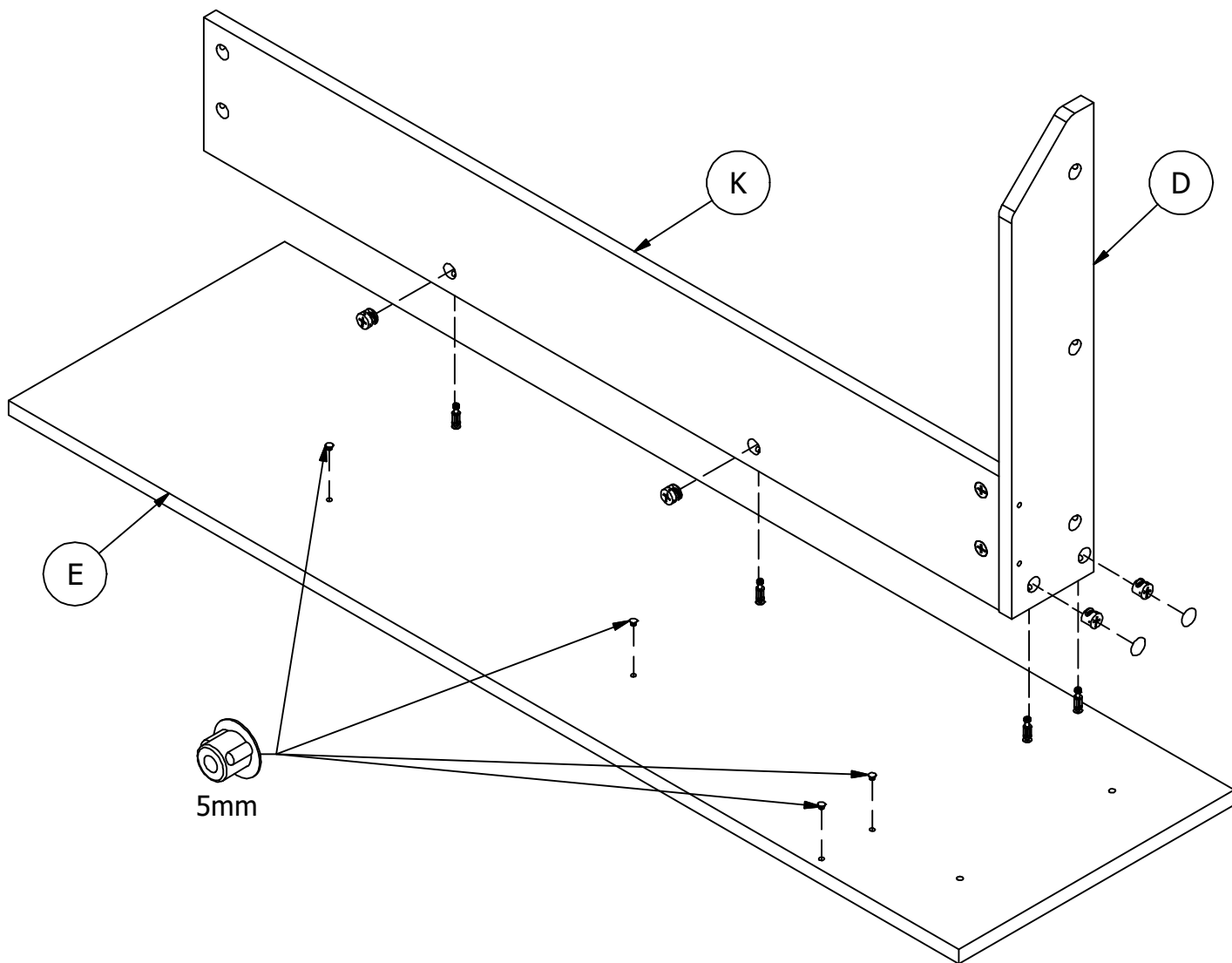
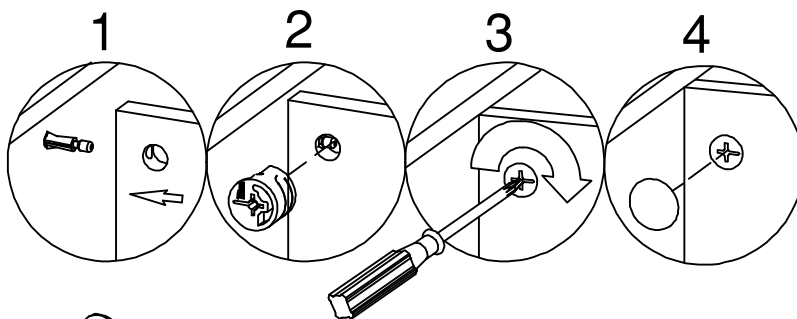

STEP 22

Assemble Panel

H71659

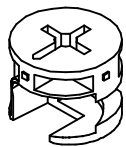

KD Cam

[3]

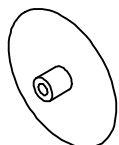

[3]

Cover Cap

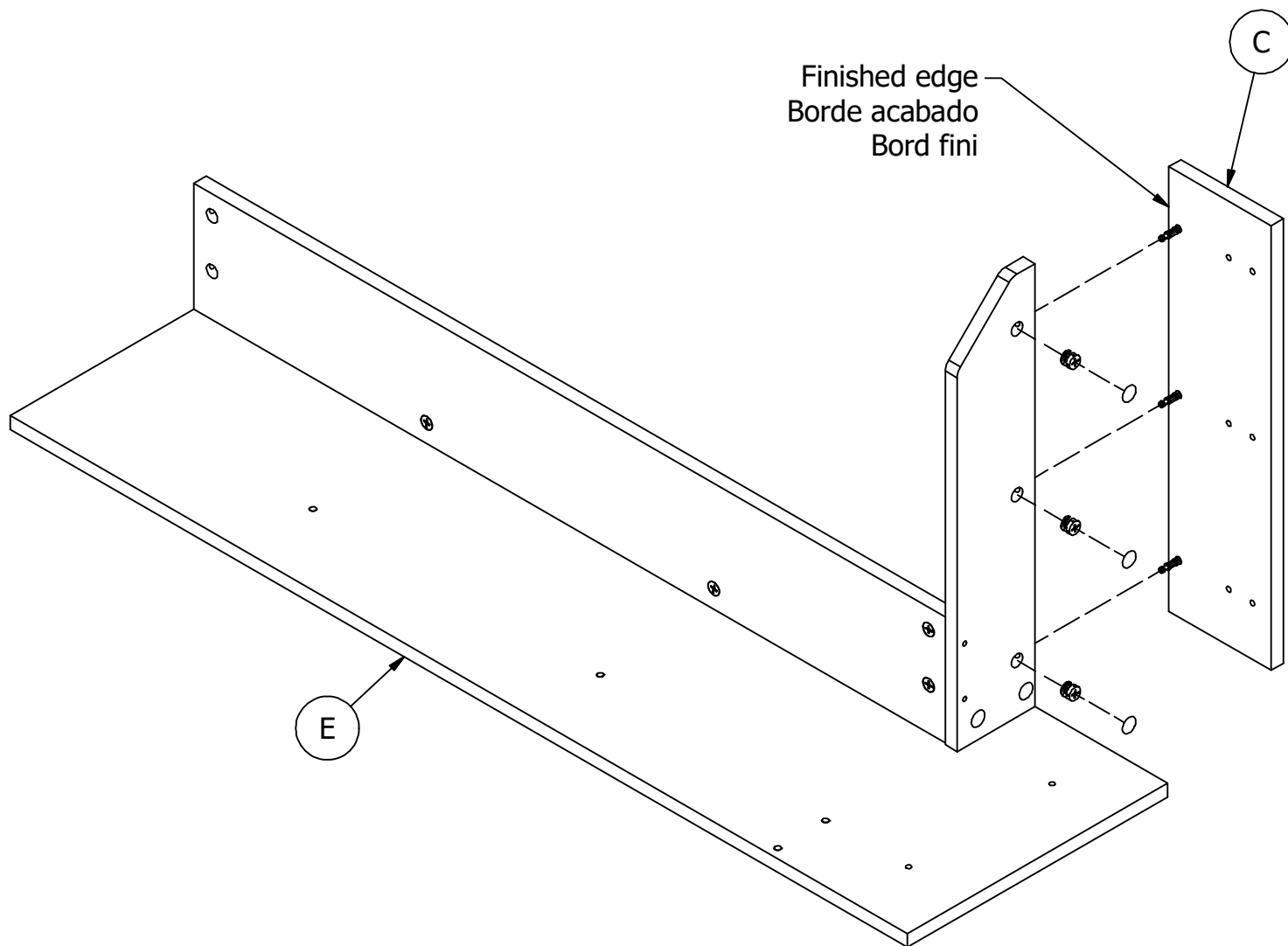
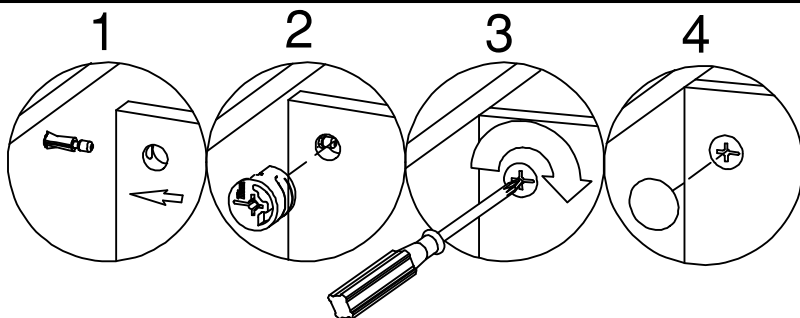

STEP 23

Assemble Base

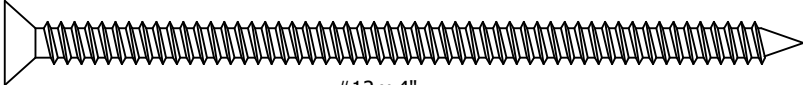
H143460  [2]
#12 x 4"

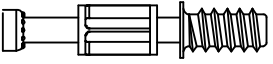
H72988  [4]
KD Bolt

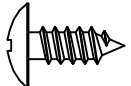
H35251  [4]
#10 x 1/2"

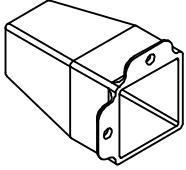
 [2]
Foot

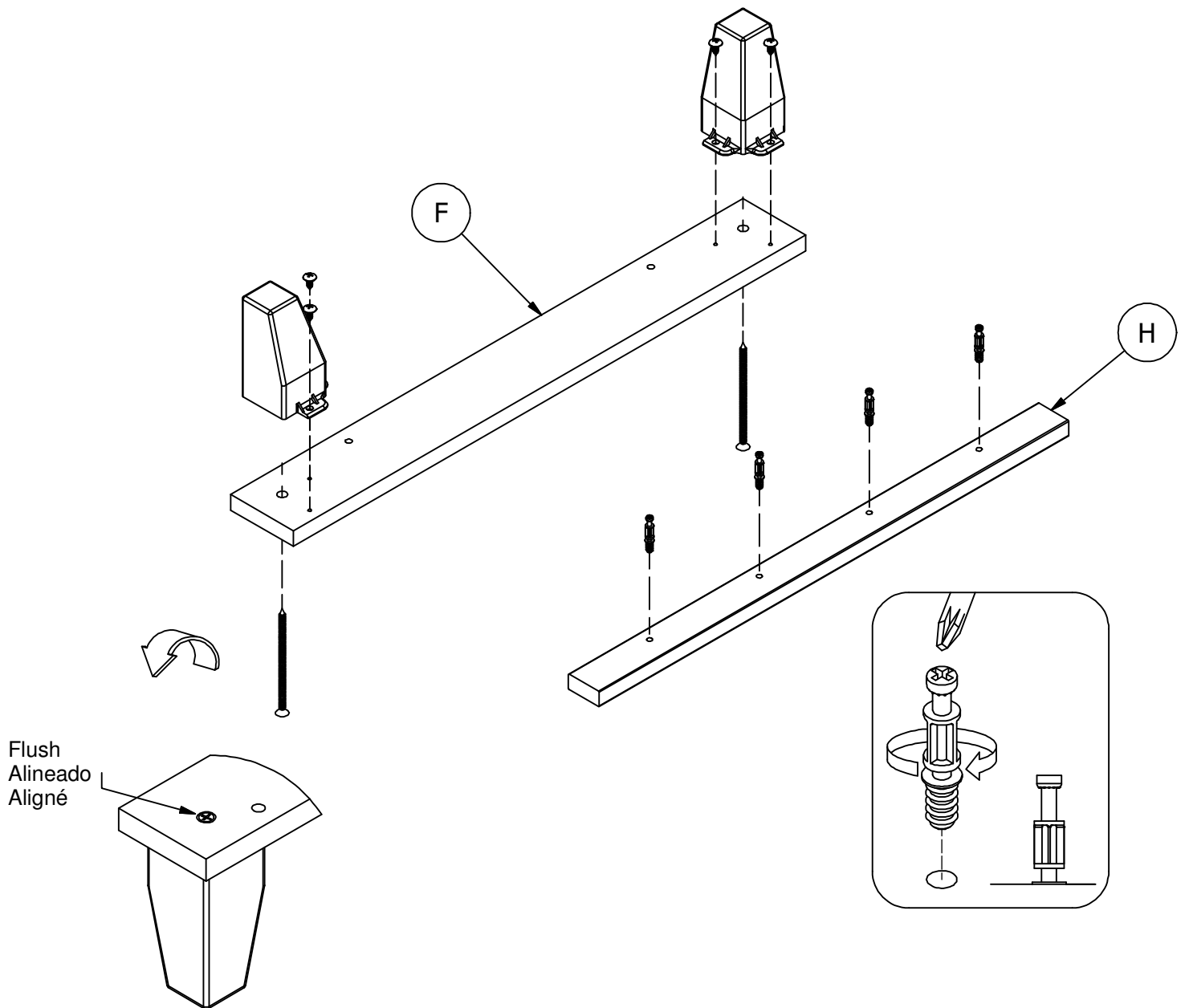

STEP 24

Prepare Panel

H72988

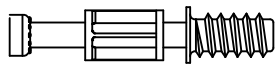

KD Bolt

[6]

H38169



Wood Dowel 8 x 30

[6]



[2]

5mm

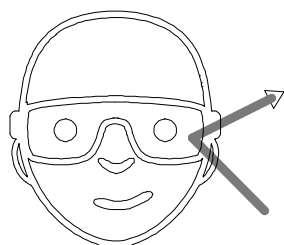
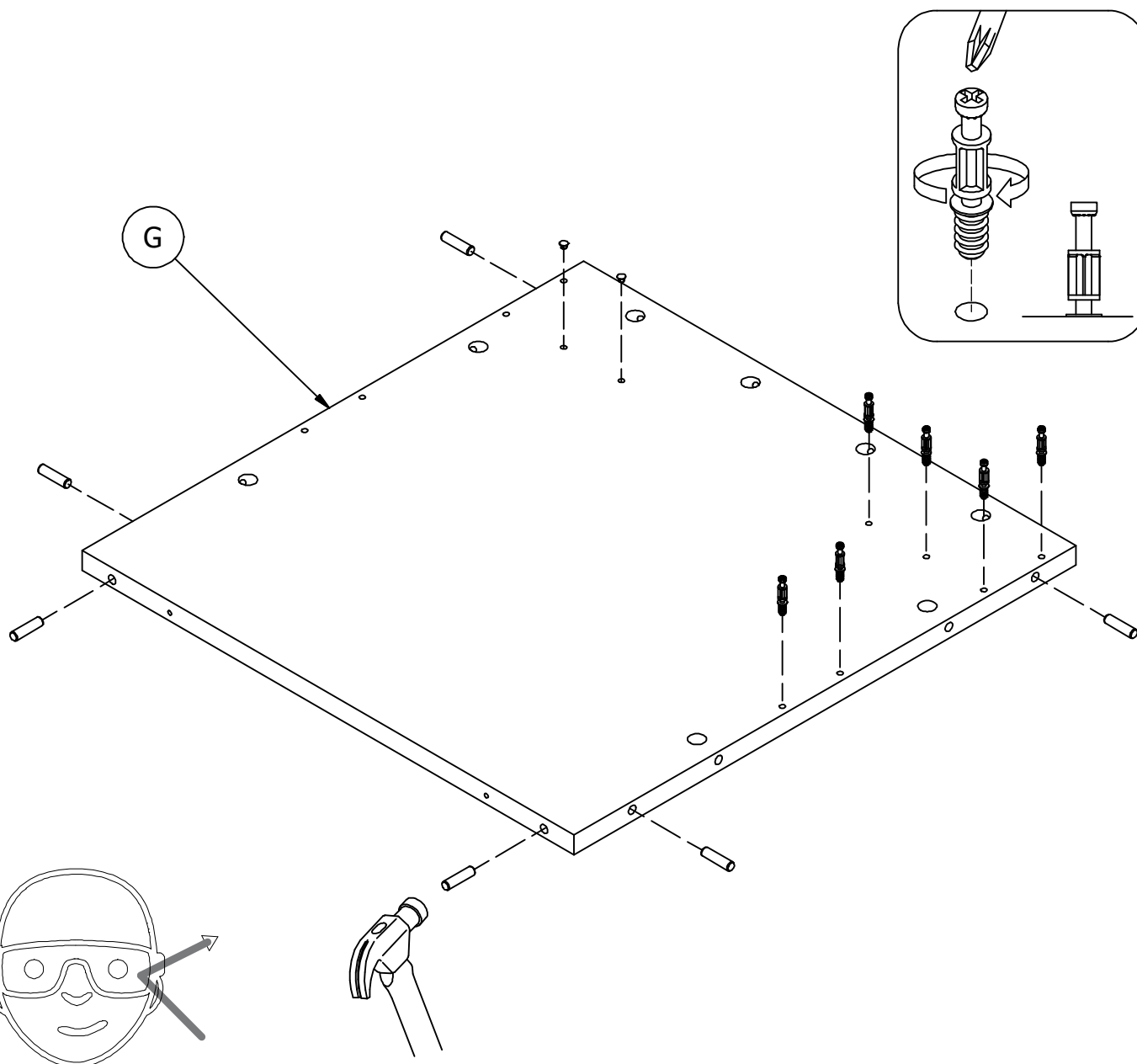

Safety glasses
Gafas de seguridad
Lunettes de protection

STEP 25

Assemble Panel

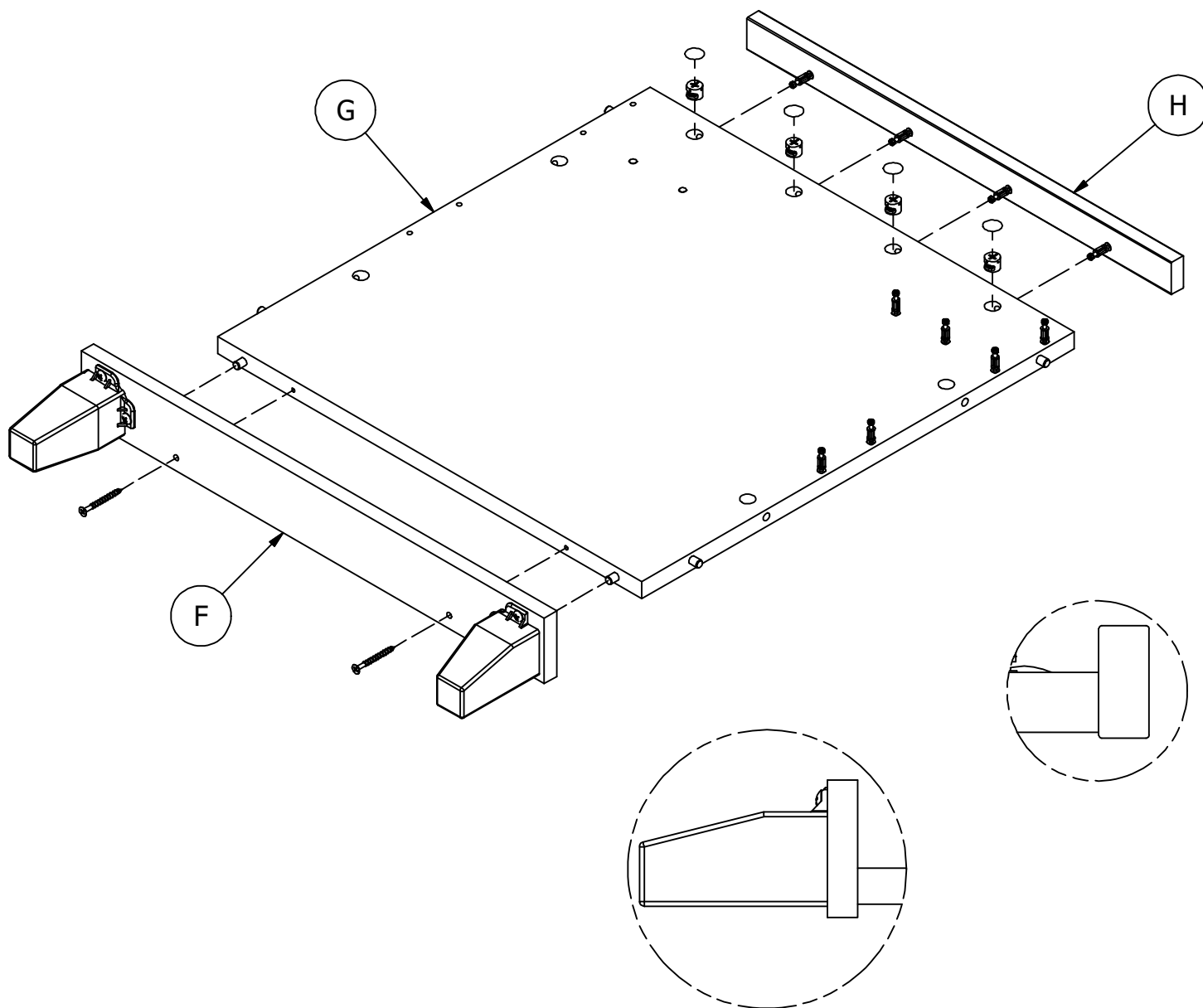
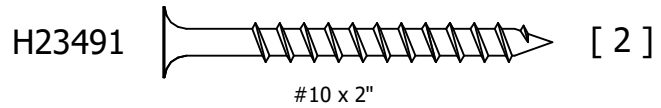
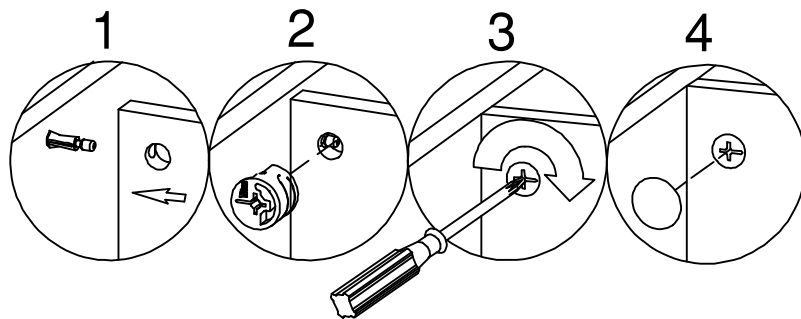
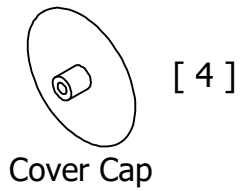
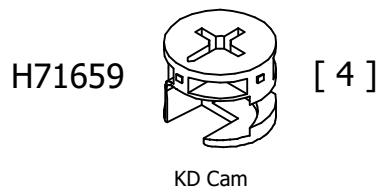

STEP 26

Prepare Rails

H72988 [4]
KD Bolt

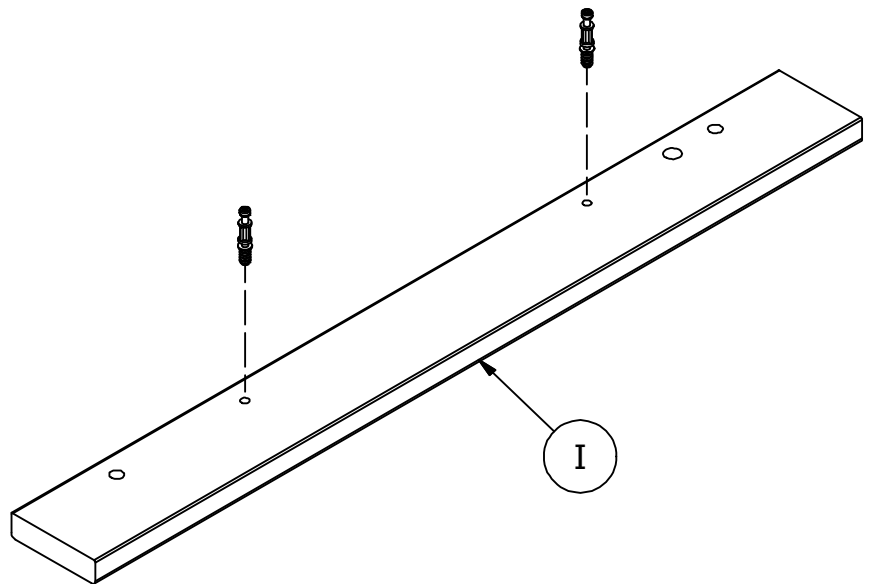
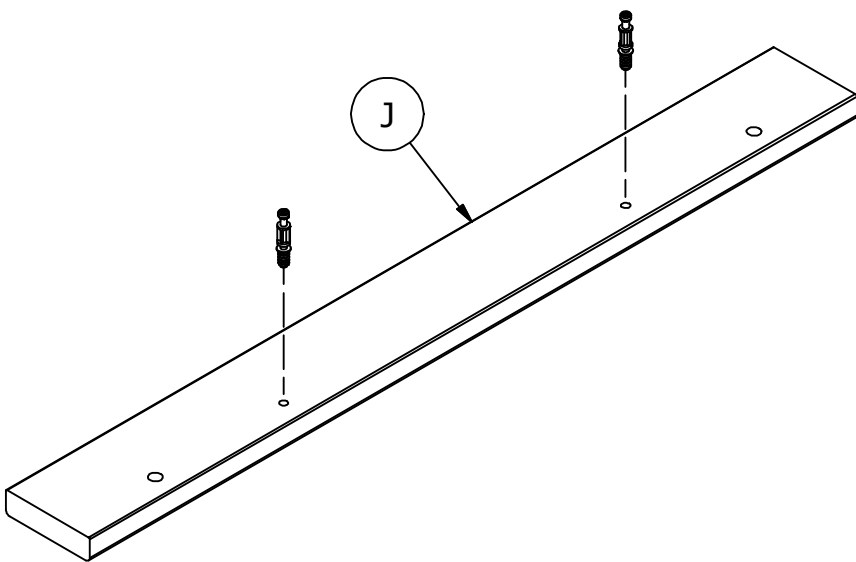
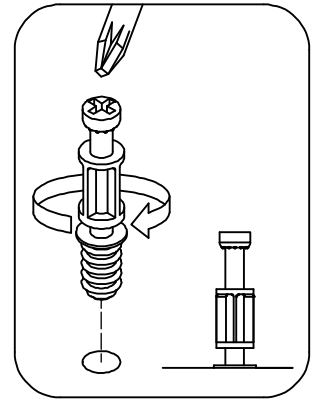

STEP 27

Assemble Modesty Panel

H71659

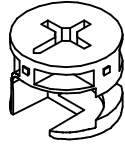

KD Cam

[6]

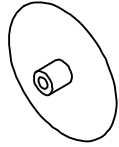

[2]

Cover Cap

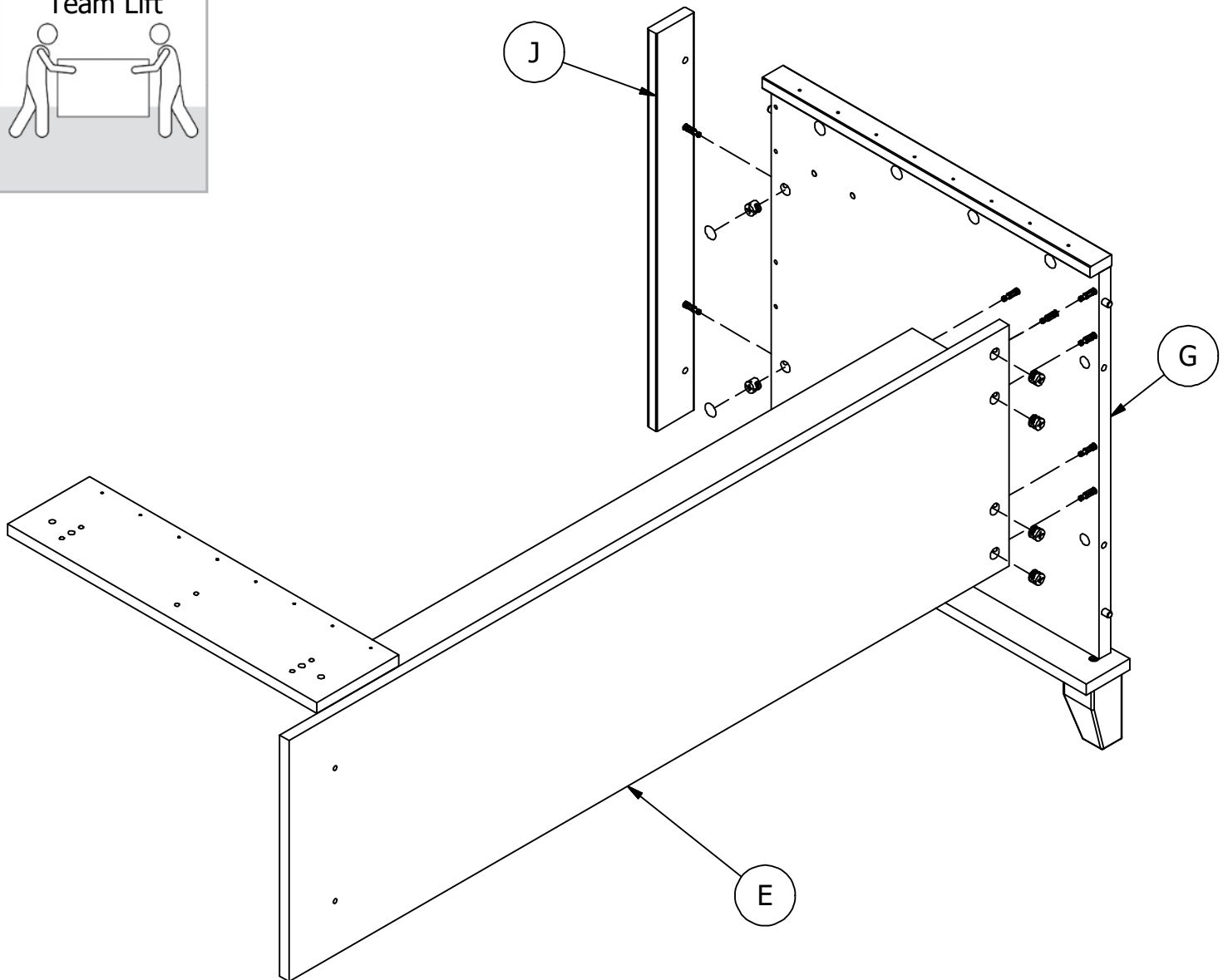
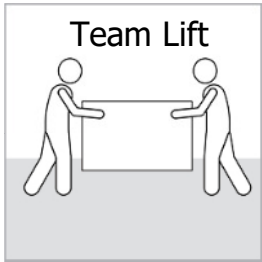
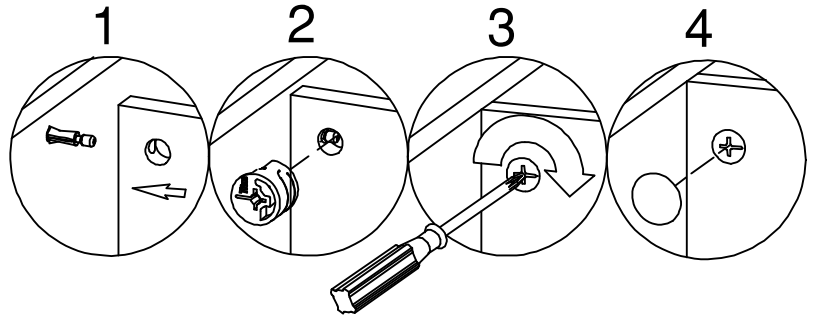

STEP 28

Assemble Panel

H71659

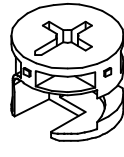

KD Cam

[4]

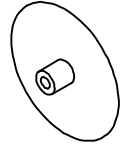

[2]

Cover Cap

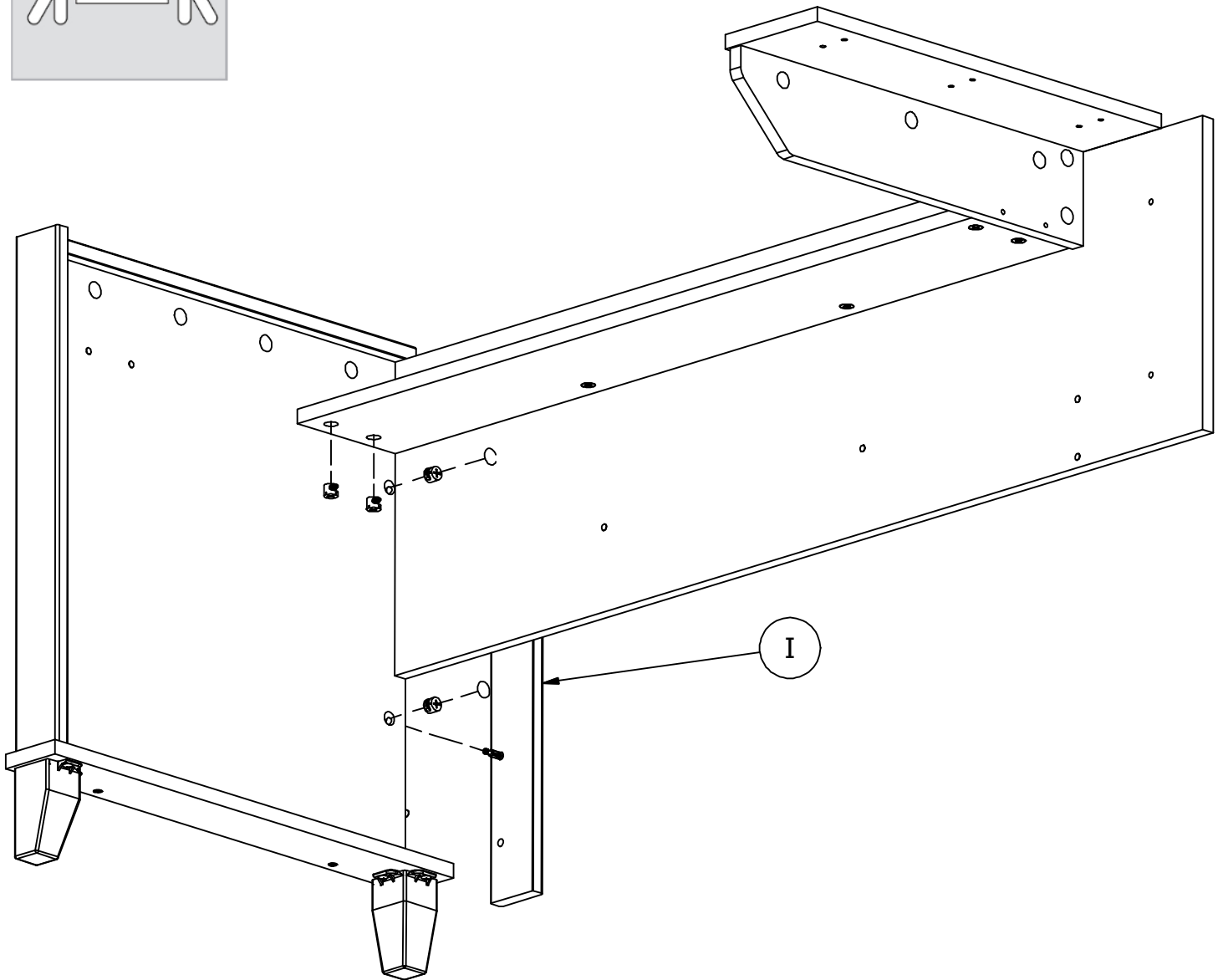
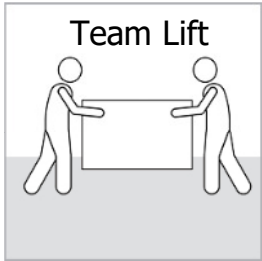
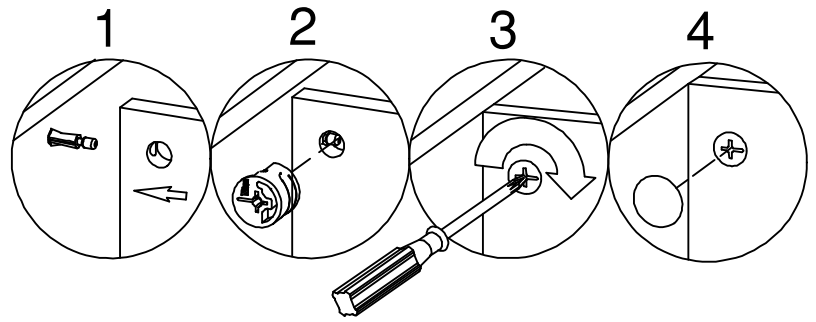

STEP 29

Remove Rail

Remove & Discard
Eliminar y desechar
Supprimer et rejeter

H35251 [3]
#10 x 1/2"

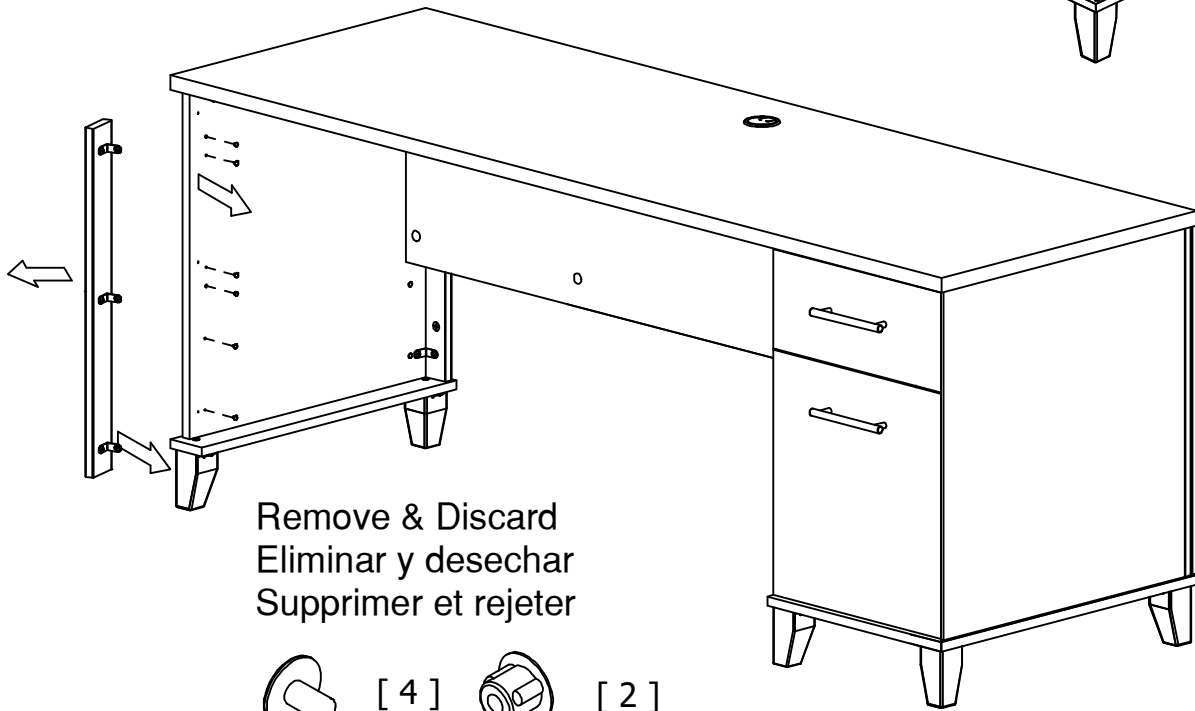
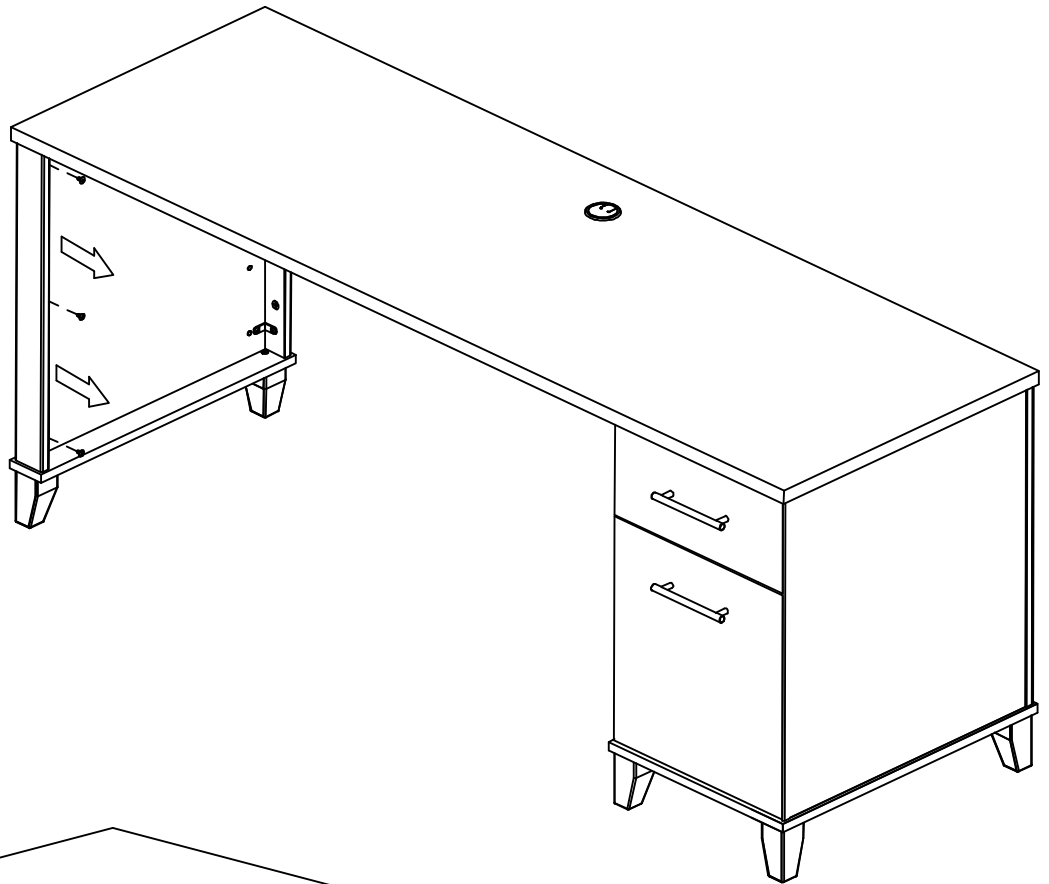
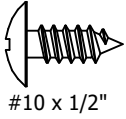

Remove & Discard
Eliminar y desechar
Supprimer et rejeter



3mm

[4]



5mm

[2]

STEP 30

Prepare Rail

H38169



[2]

Wood Dowel 8 x 30

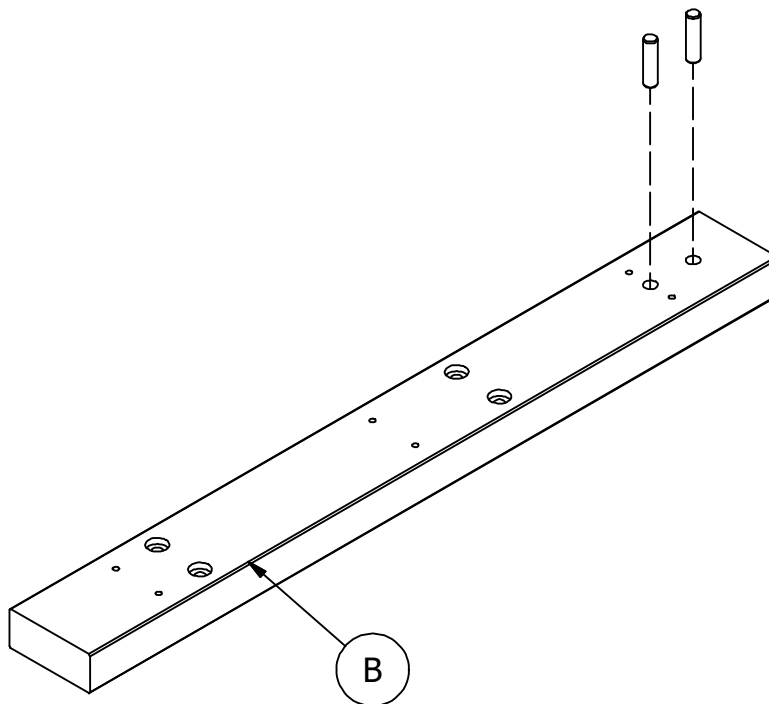

STEP 31

Assemble Rail

H23468



#10 x 1-1/2"

[4]

Assemble in final location.
Arme la unidad en el lugar destinado.
Assemblez en position finale

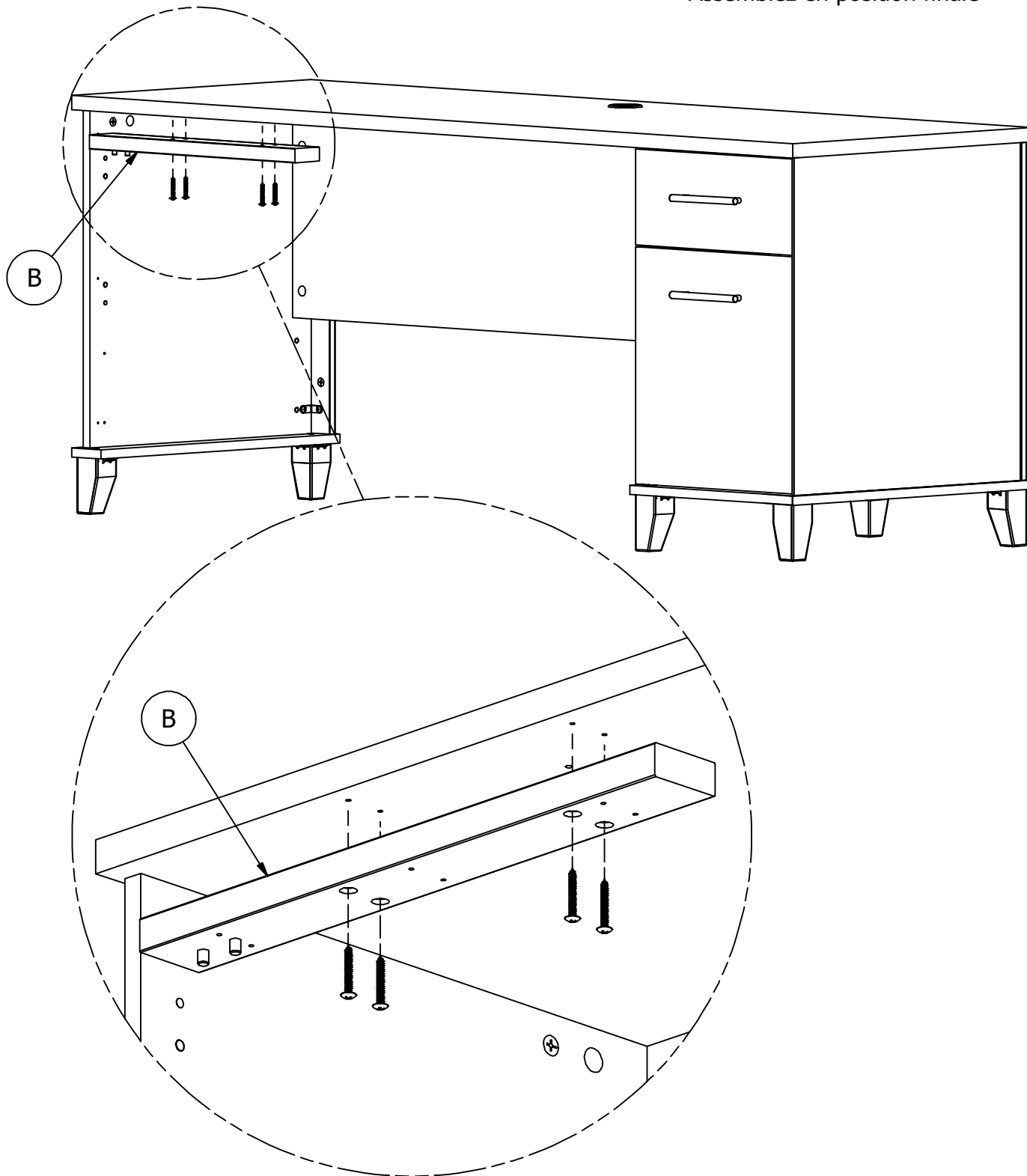

STEP 32

Attach Modesty Panel

Team Lift

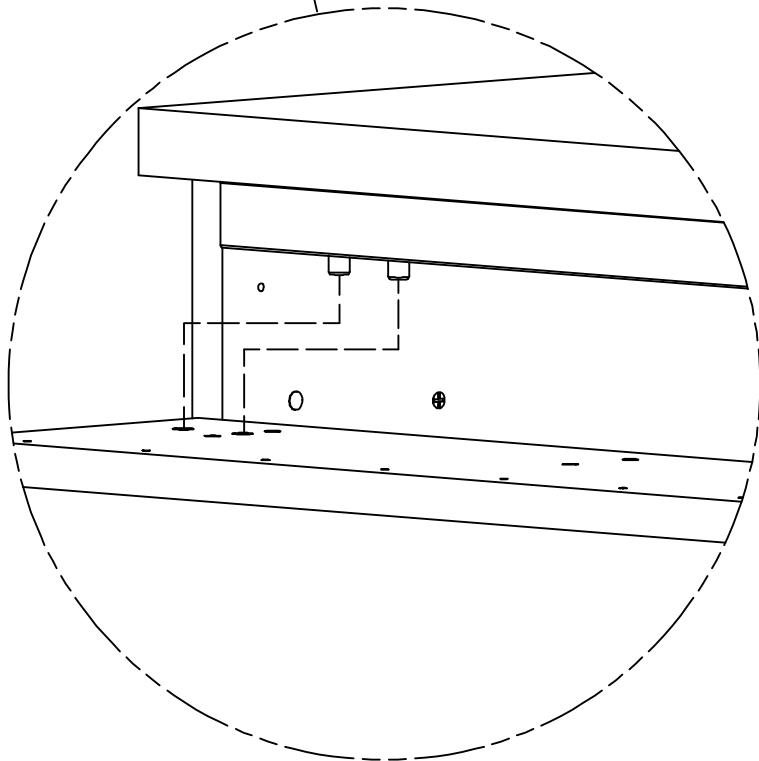
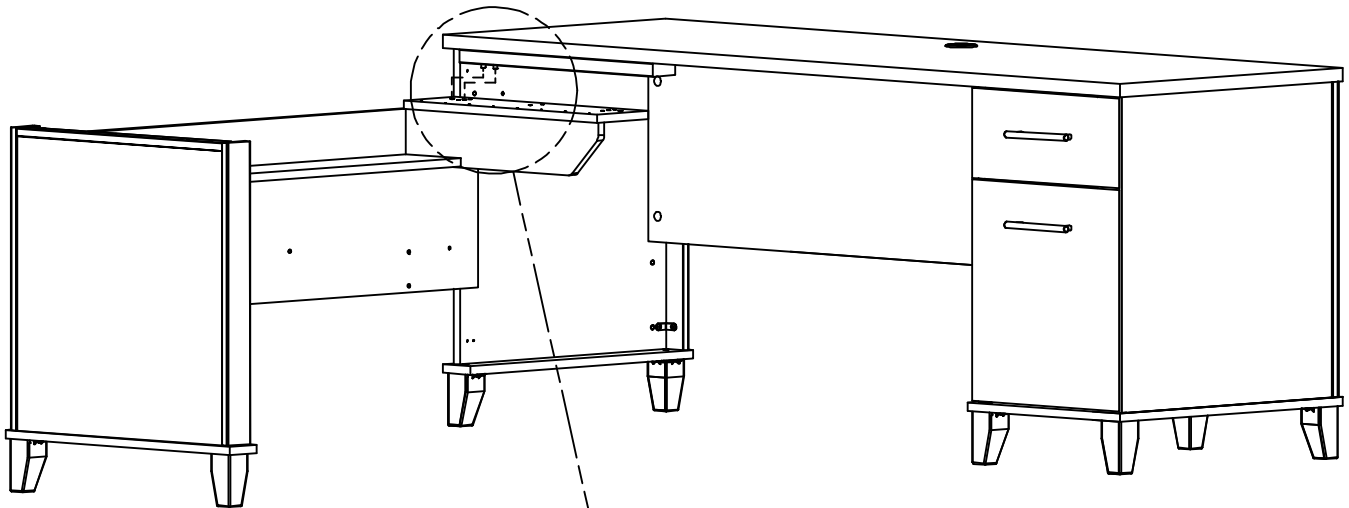
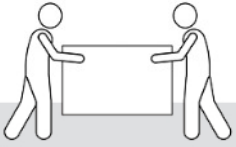

STEP 33

Attach Modesty Panel

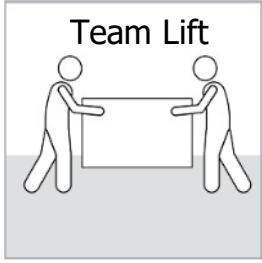

H23682



[2]

#10 x 1"

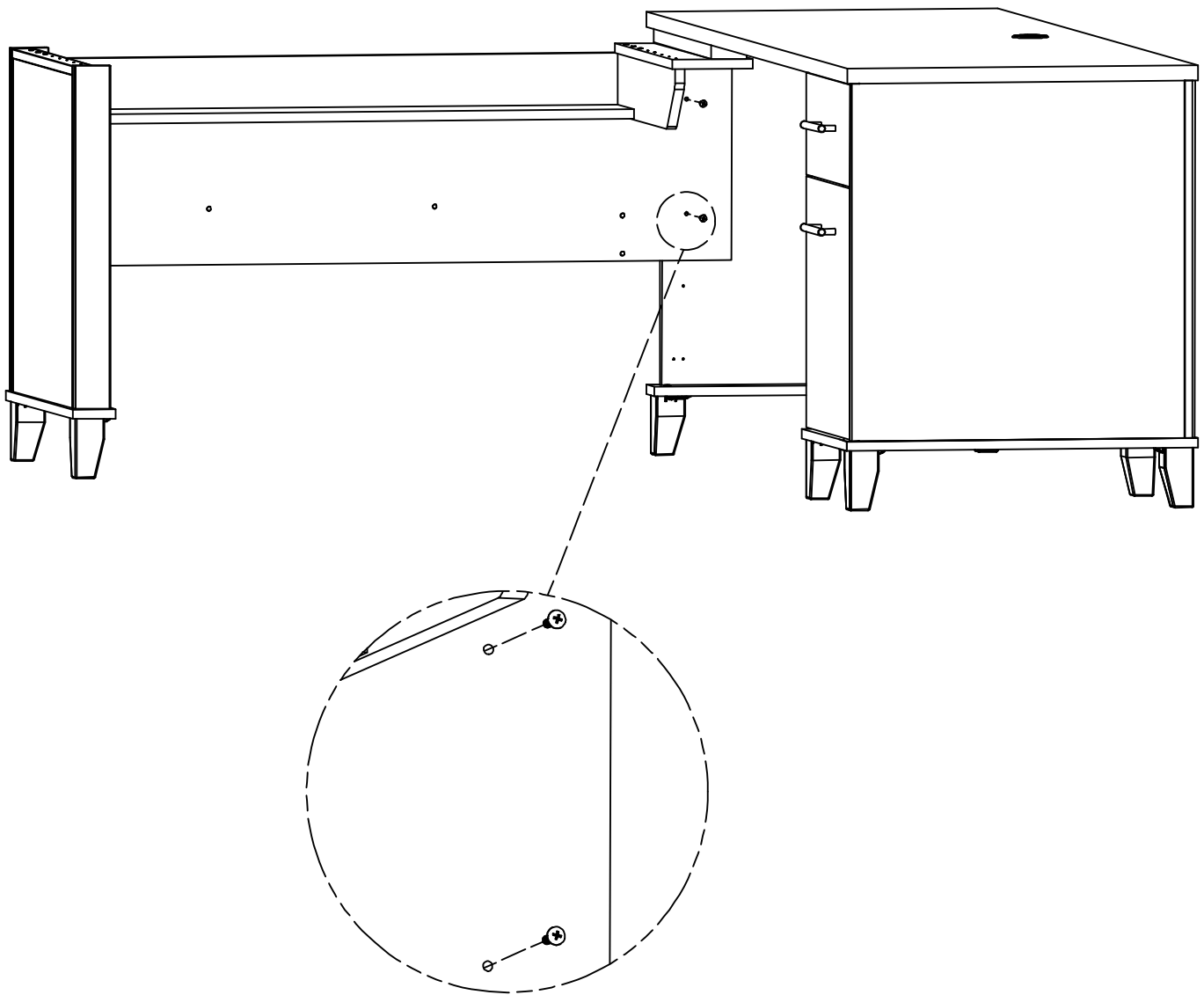

STEP 34

Attach Modesty Panel

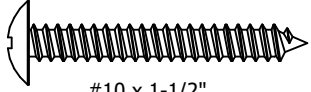
H23468  [6]
#10 x 1-1/2"

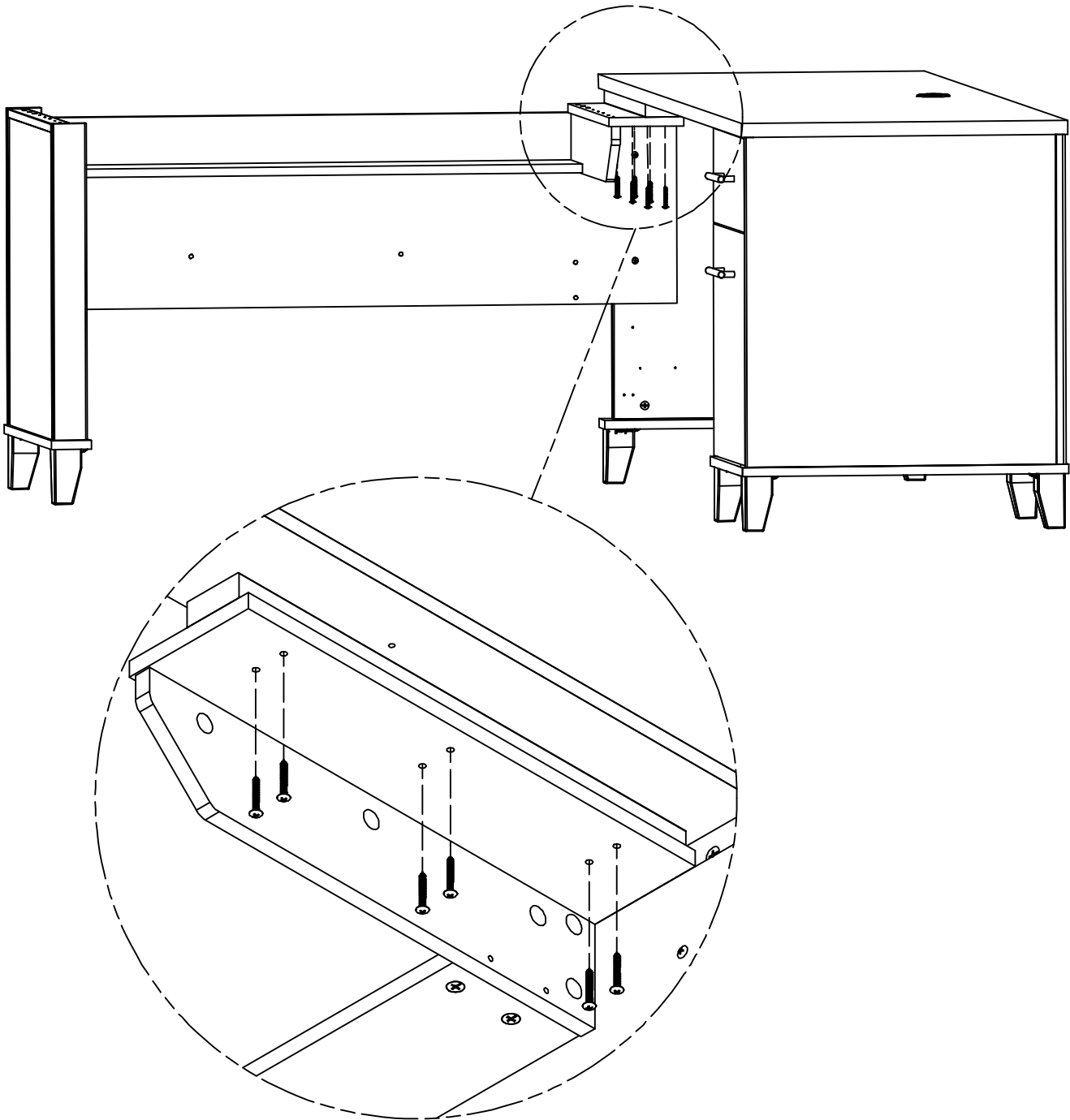

STEP 35

Attach Rail

H35251 [4]
#10 x 1/2"

H67187 [2]
Angle Bracket

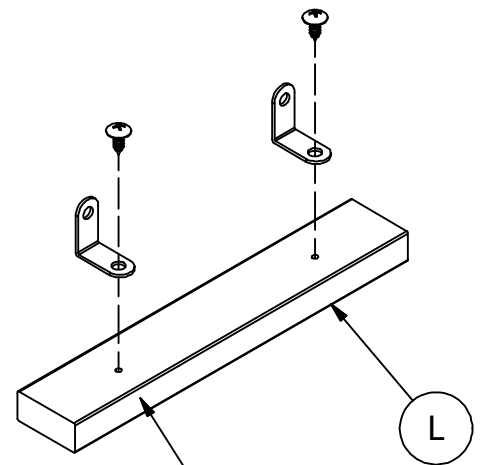

Finished edge
Borde acabado
Bord fini

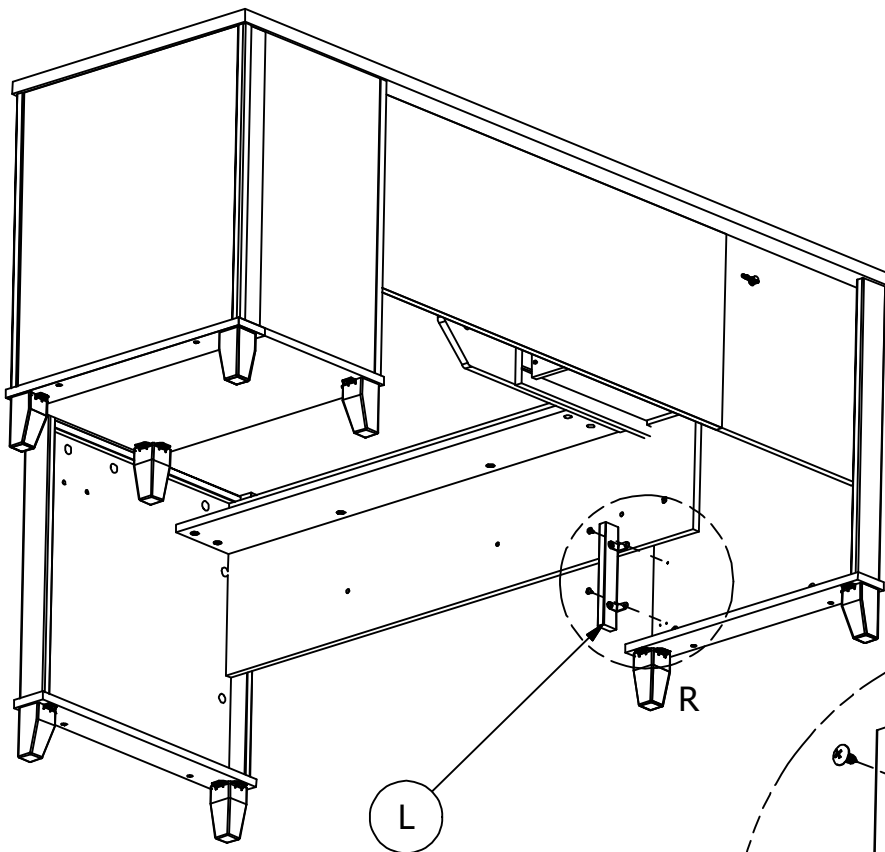

L

L

Finished edge
Borde acabado
Bord fini

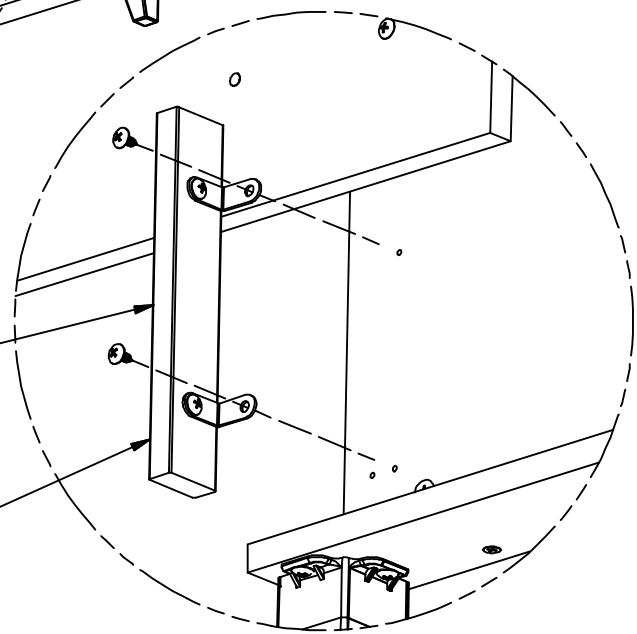

STEP 36

Attach Stand

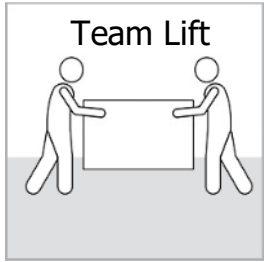

Z184666

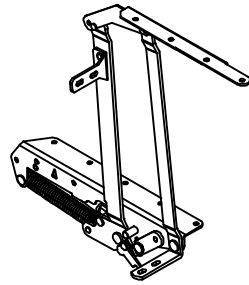

[1]

H23119

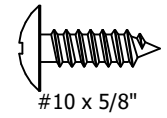

[5]

#10 x 5/8"

Right Side Mechanism

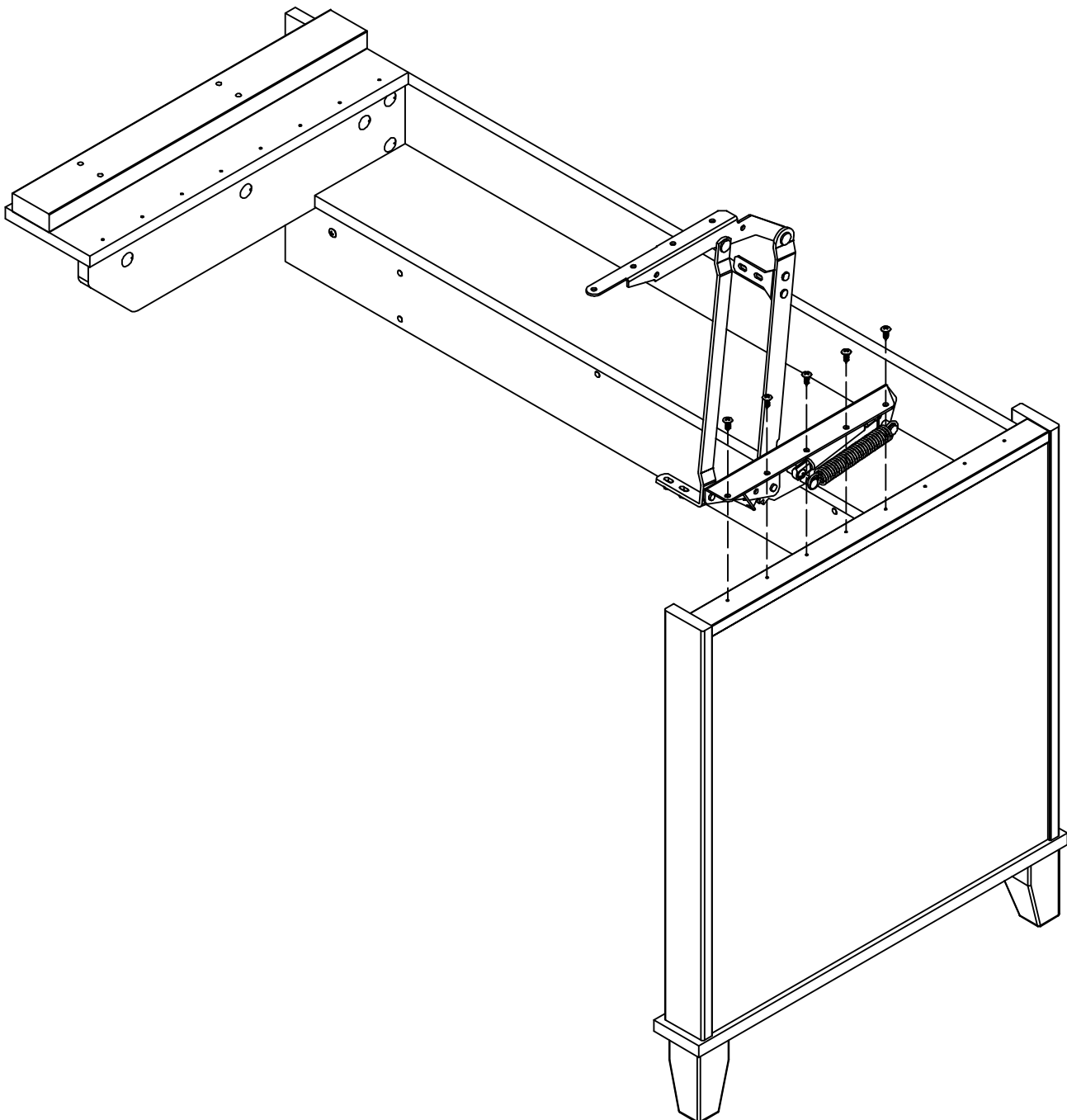

STEP 37

Attach Stand

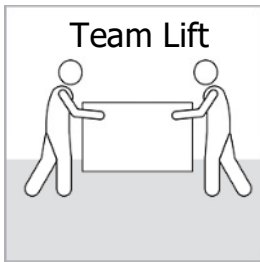

Z184667

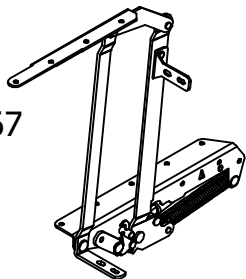

[1]

Left Side Mechanism

H23119

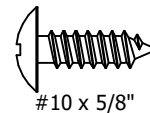

[5]

#10 x 5/8"

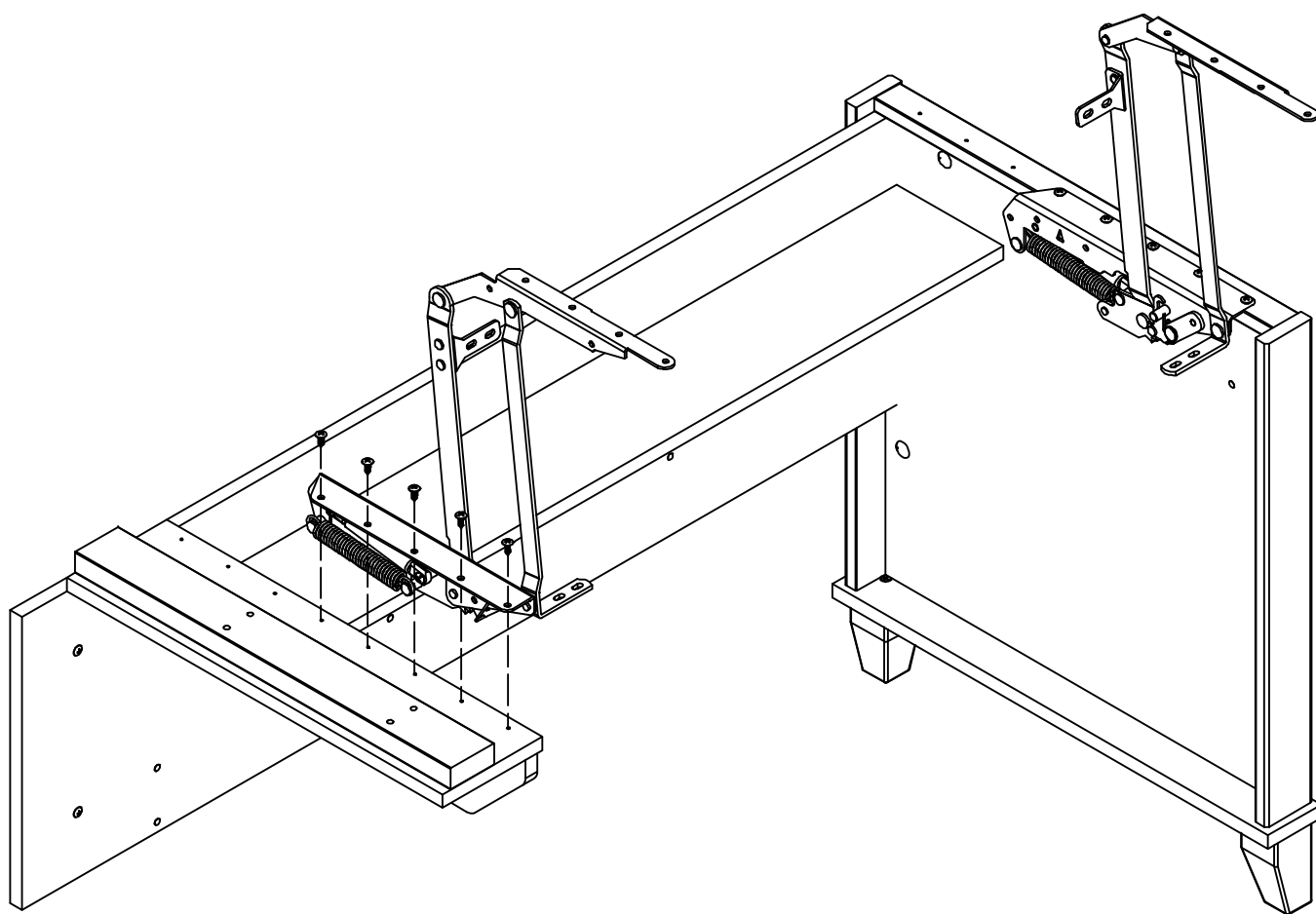

STEP 38

Prepare Top

H181315

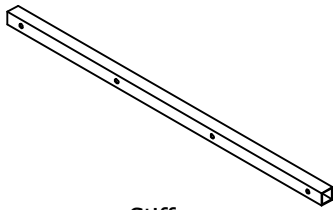

[1]

Stiffener

H23468

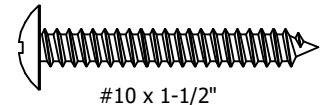

[4]

#10 x 1-1/2"

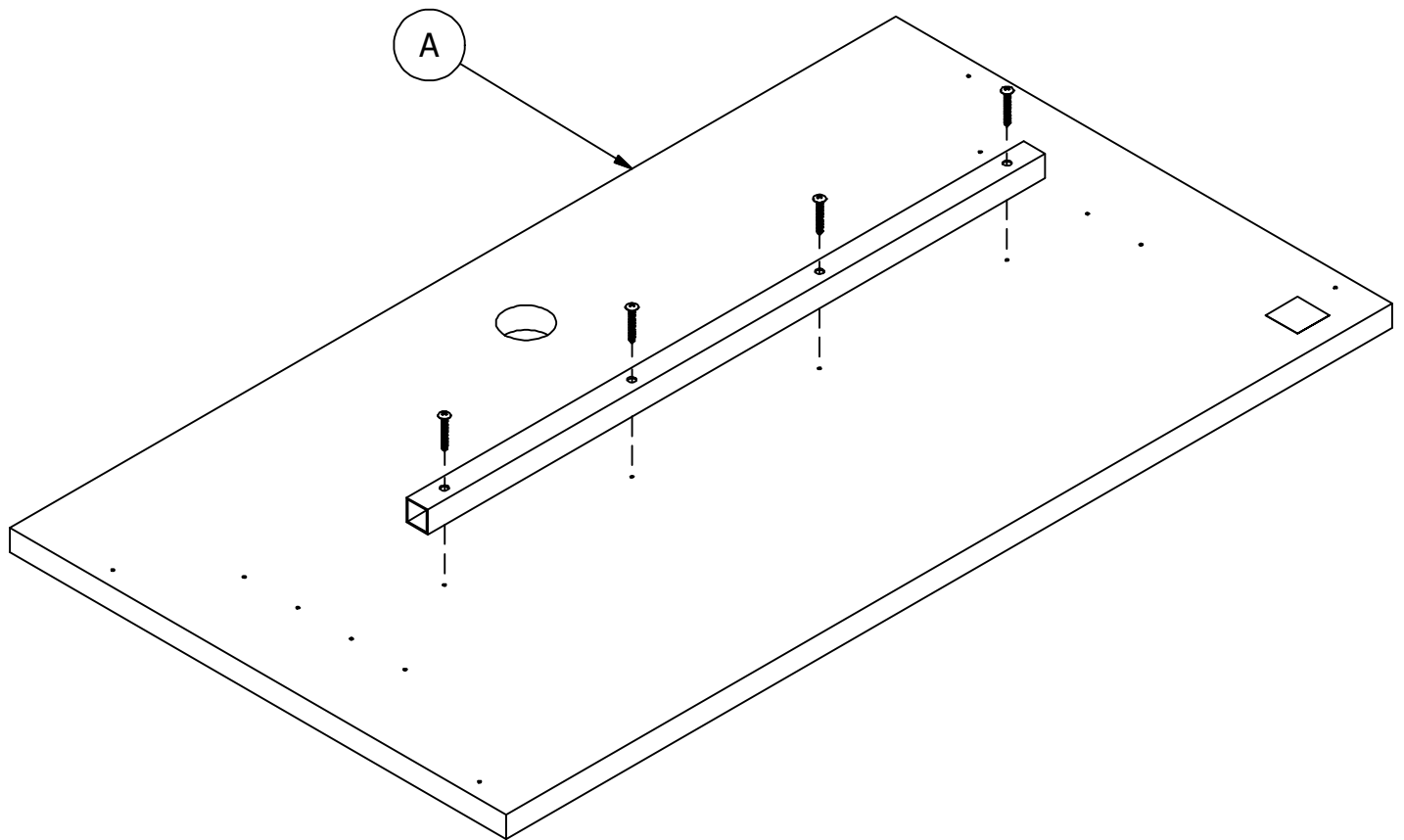

STEP 39

Attached Bumpers

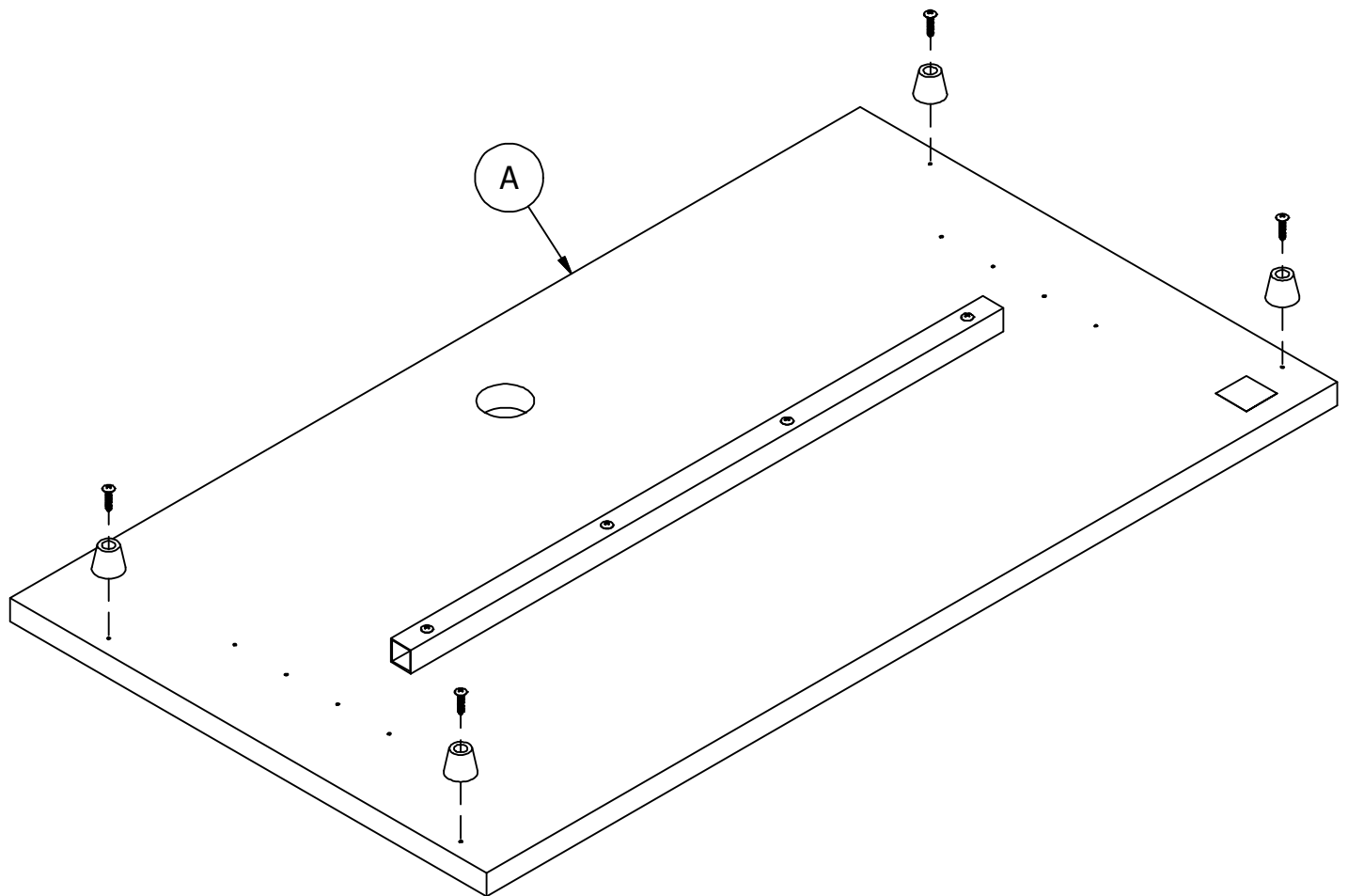
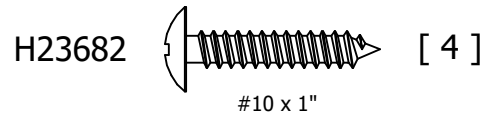
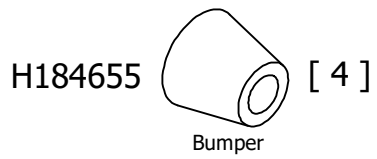

STEP 40

Assemble Work Surface

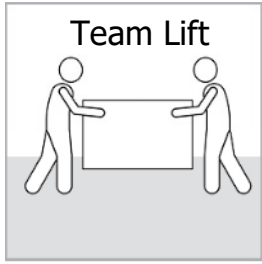

H23119

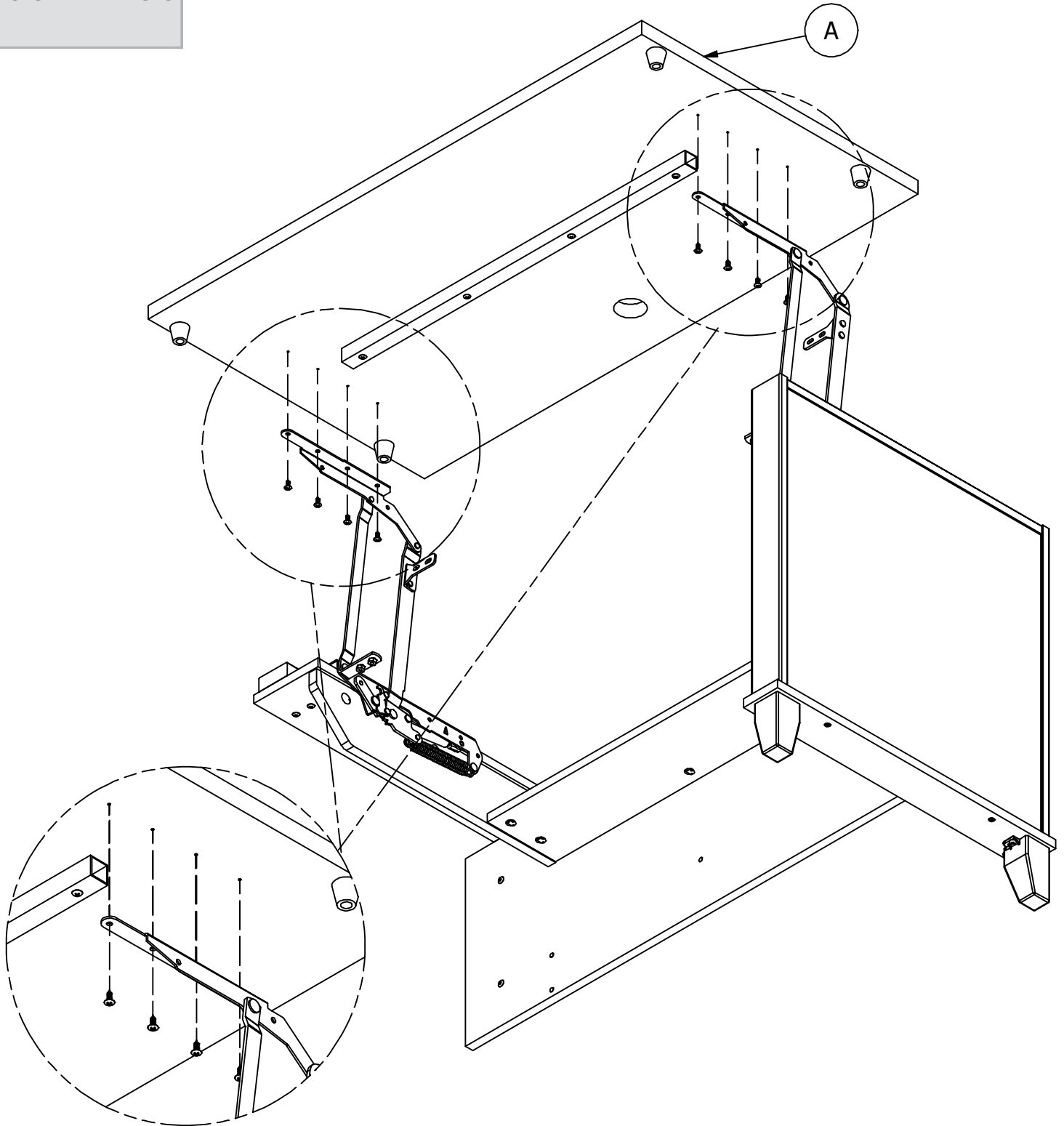
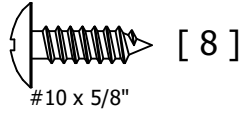

STEP 41

Attach Supports

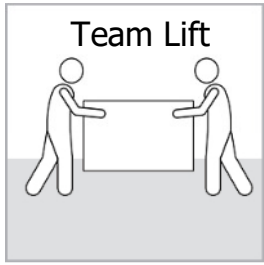

H189068

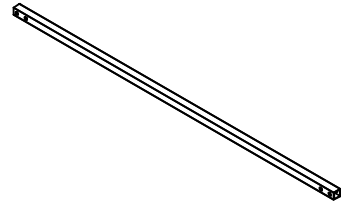

[2]

Connecting Bar

Z184671

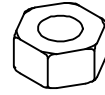

[8]

Nut 1/4-20

Z184669



[8]

1/4-20 x 28mm

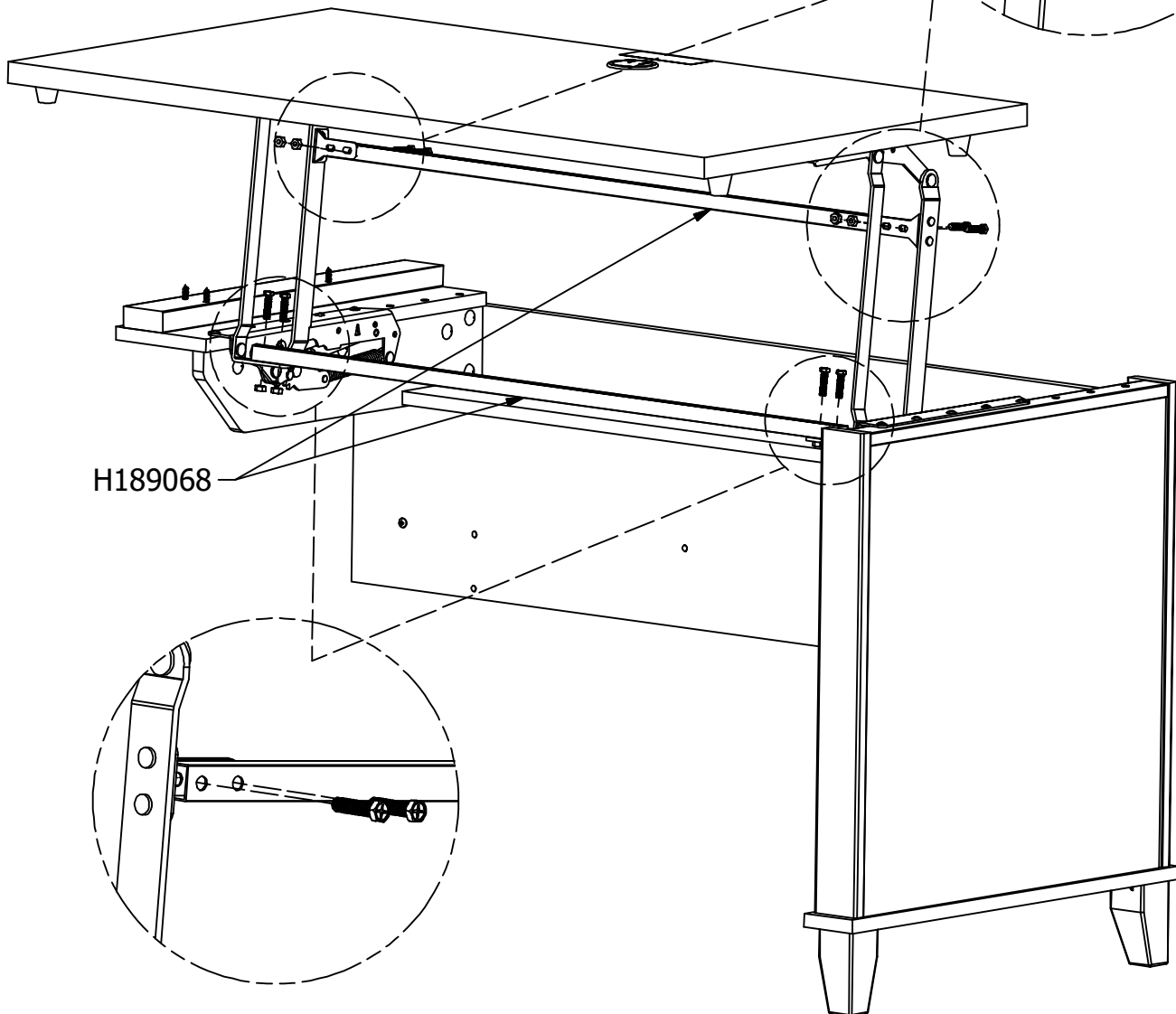
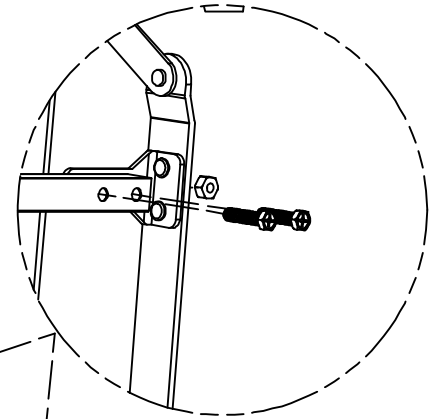

H189068

STEP 42

Attach Supports

H157577



[4]



[6]

3mm

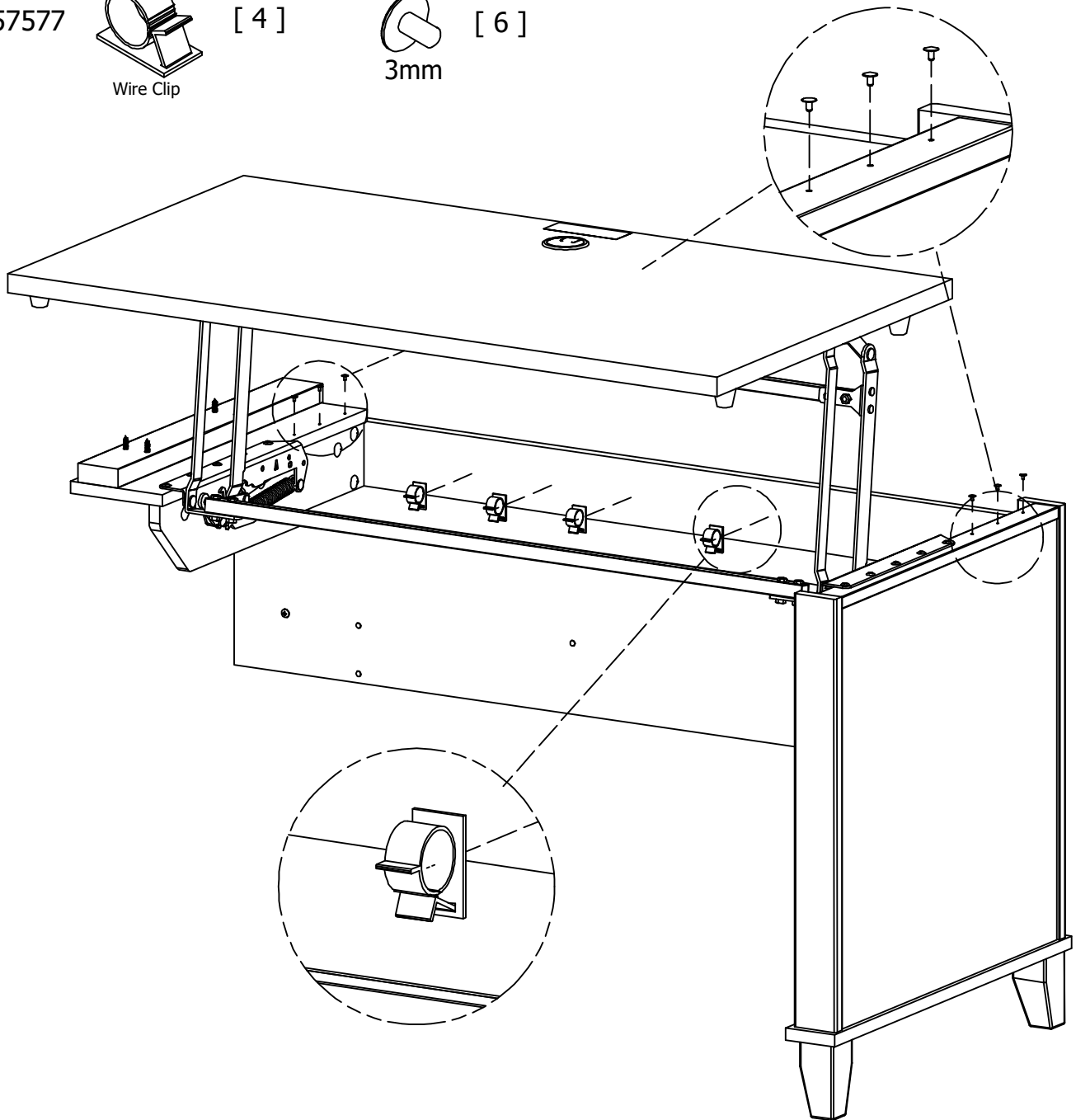

STEP 43

Insert Grommet and Loading

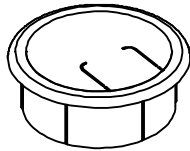

[1]

Grommet

Gently clean surfaces with a damp sponge eraser.

Maximum Weight: 20.0 Lbs
Peso Máximo: 20.0 Libras
Poid Maximum: 9.07 kilogramme

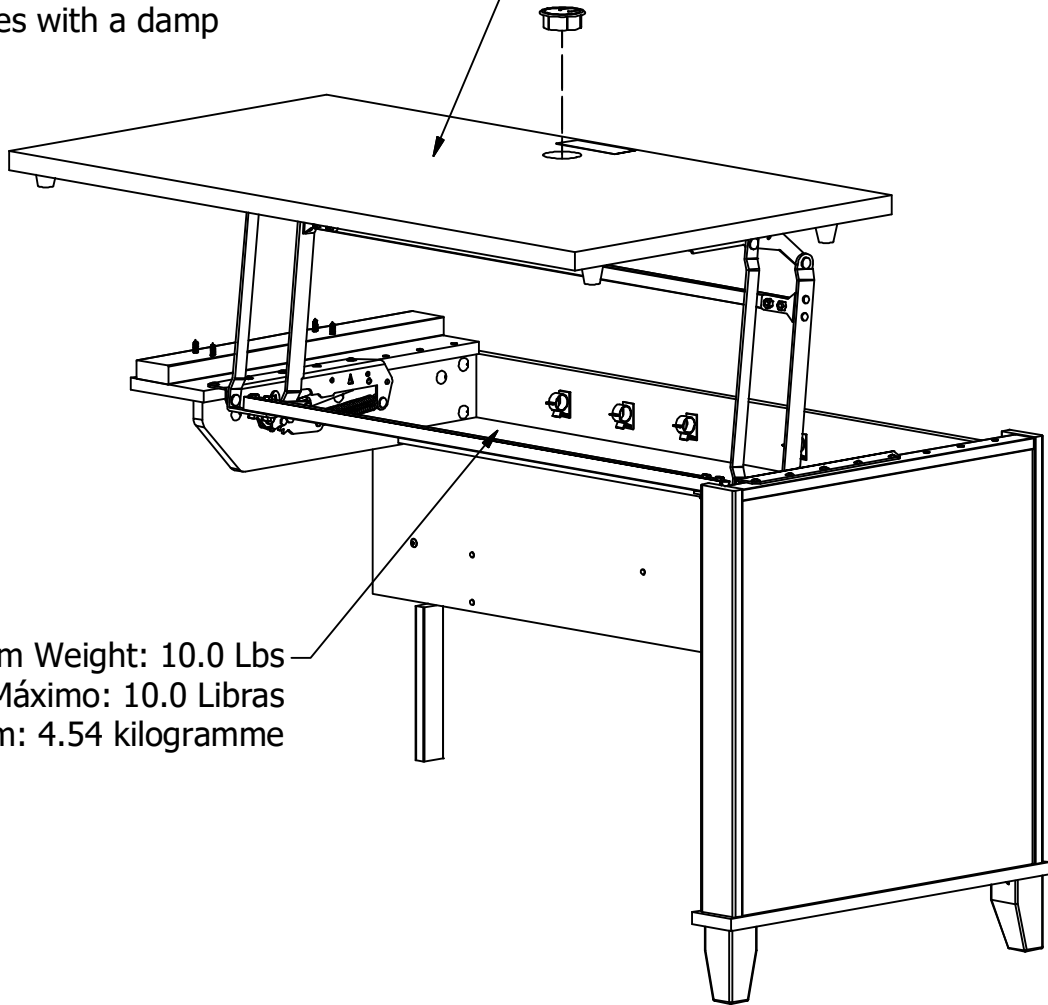

Maximum Weight: 10.0 Lbs
Peso Máximo: 10.0 Libras
Poids Maximum: 4.54 kilogramme

Congratulations! You are all done. If you have any questions or concerns, please call.

STEP 44

Sit To Stand

SEATED POSITION

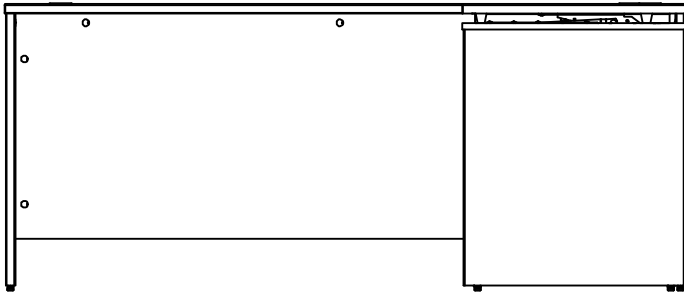

POSITION #1

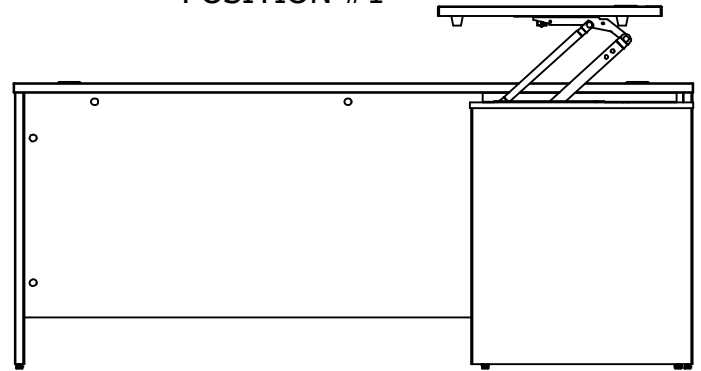

POSITION #2

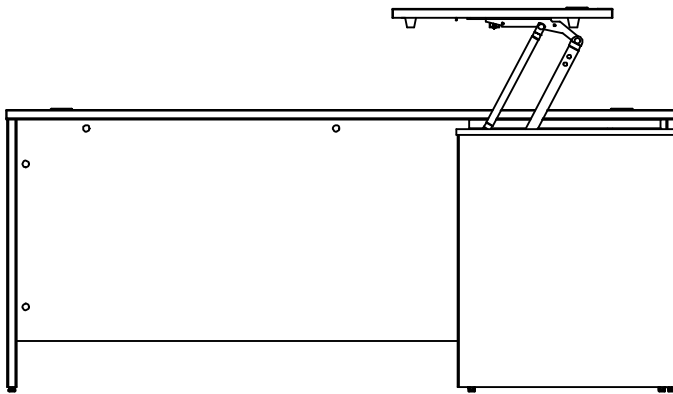

POSITION #3

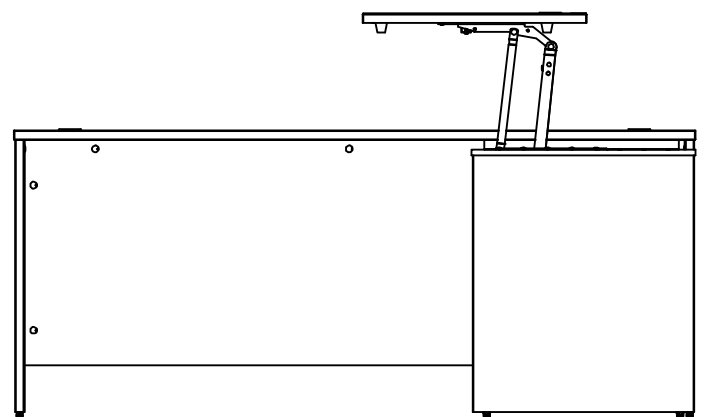

UNLOCK POSITION

A)

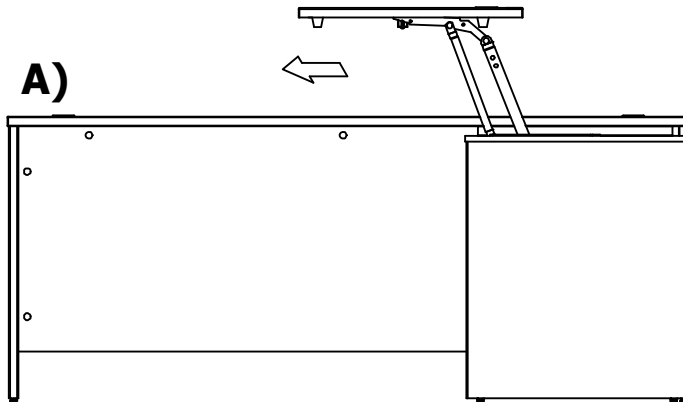

B)

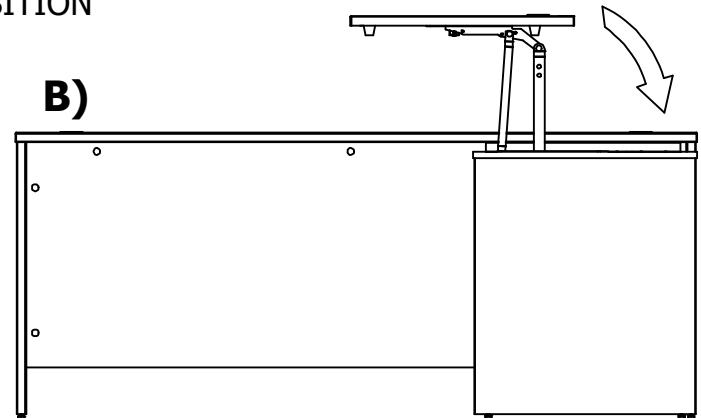

DO NOT use desk top in UNLOCK position
NO use el escritorio en la posición de DESBLOQUEO
NE PAS utiliser le bureau en position UNLOCK

To return desk to seated position:

- (A) Pull desk top slowly forward until stop
- (A) Tire del escritorio lentamente hacia adelante hasta que se detenga
- (A) Tirez le bureau lentement vers l'avant jusqu'à la butée

- (B) Slowly push desk top down to seated position
- (B) Empuje lentamente la parte superior del escritorio hacia abajo hasta la posición sentada
- (B) Poussez lentement le bureau en position assise

PARTS LIST

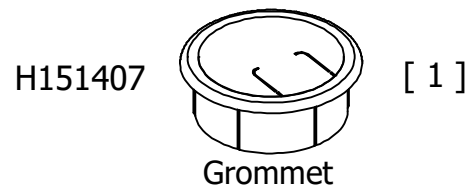
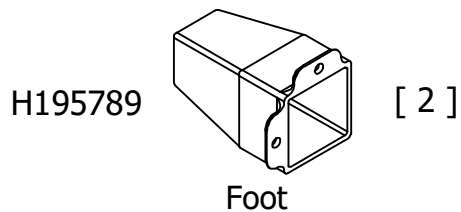
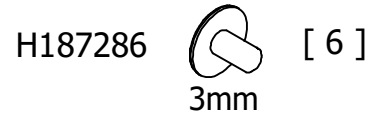
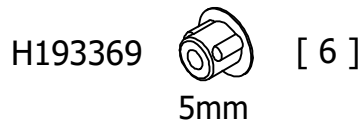
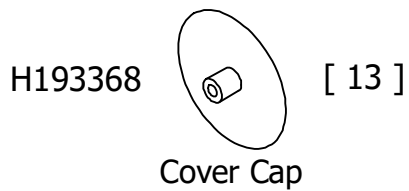
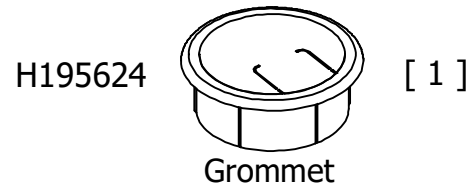
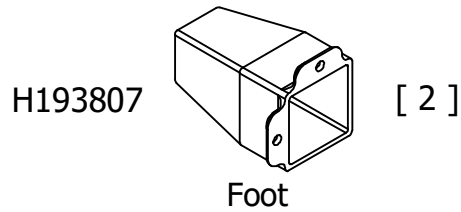
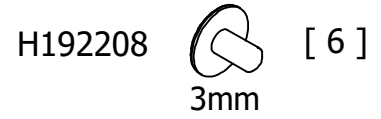
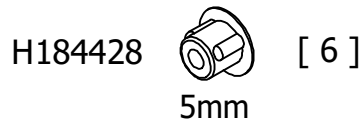
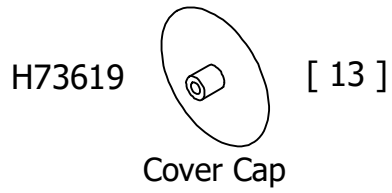

PARTS LIST

H83021 [13]

Cover Cap

H112099 [6]

5mm

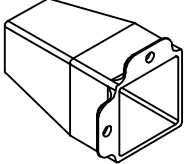
H187286 [6]

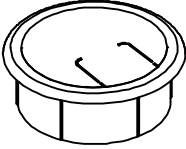
3mm

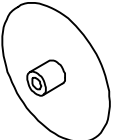
H195789 [2]

Foot

H118700 [1]

Grommet

H73620 [13]

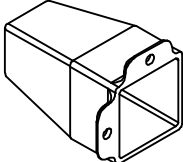
Cover Cap

H96670 [6]

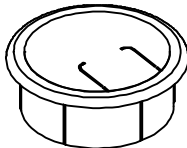
5mm

H187287 [6]

3mm

H200227 [2]

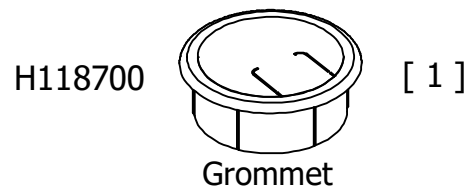
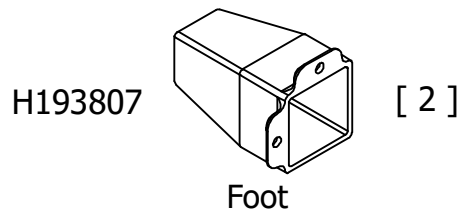
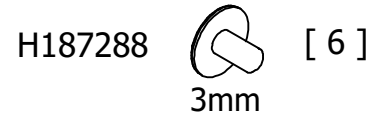
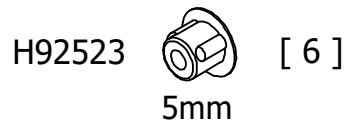
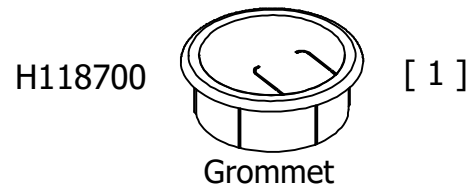
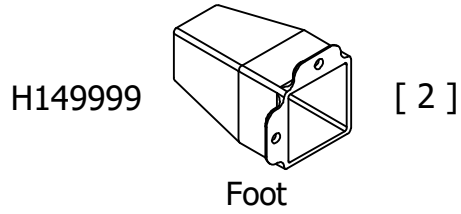
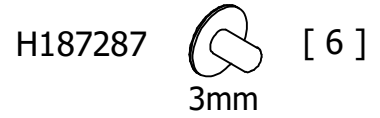
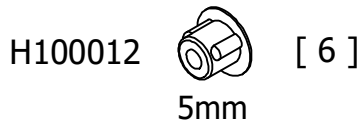
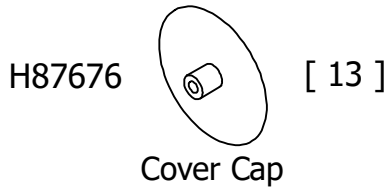
Foot

H118700 [1]

Grommet

PARTS LIST

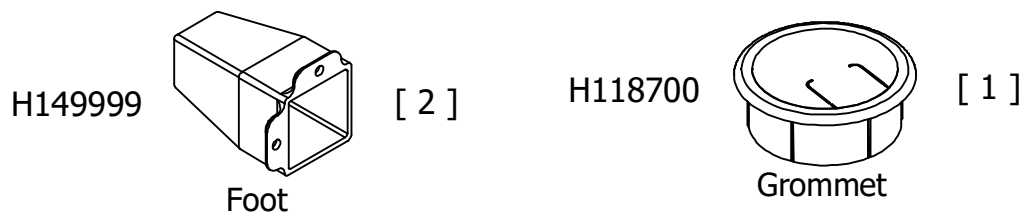
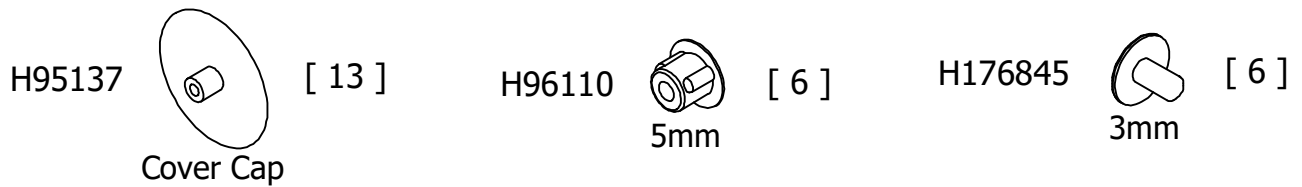
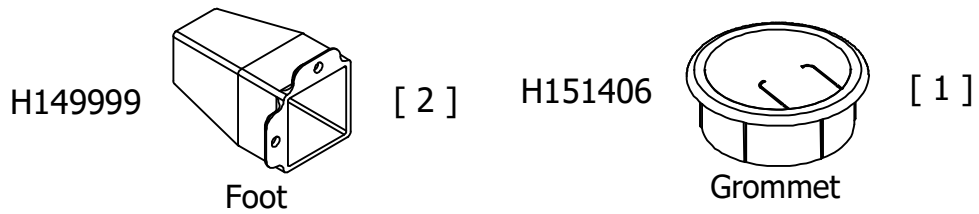
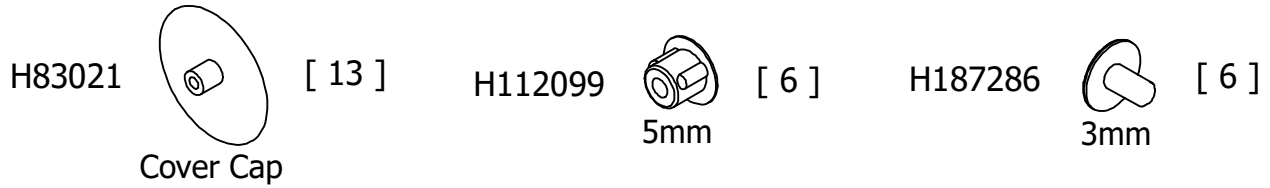

PARTS LIST



PARTS LIST

