







ASSEMBLY INSTRUCTIONS

Thank you for purchasing this quality product . Be sure to check all packaging material carefully for small parts that may have come loose inside the carton during shipment .

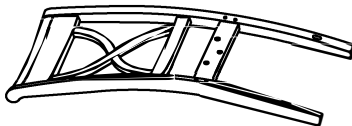





"Hardware is attached underneath the seat bottom"

This product will take 15-20 minutes to assemble

Components List :

NO	DESCRIPTION	SKETCH	QTY
A	Back Rest		1pc
B	Wooden Seat		1pc
C	Front Leg (Left)		1pc
D	Front Leg (Right)		1pc
E	Side Stretcher (Left)		1pc
F	Side Stretcher (Right)		1pc
G	Center Stretcher		1pc

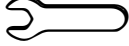
Hardware List :

NO	DESCRIPTION	SIZE	SKETCH	QTY
1	Allen Key	58x23x4 mm		1pc
2	Short Bolt	1/4" x38 mm		3pcs
3	Long Bolt	1/4" x85 mm		4pcs
4	Spring Washer	5/16" x Ø12		11 pcs
5	Flat Washer	5/16" x Ø19		11 pcs
6	Wrench	12x75 mm		1pc
7	Hex-Nut	5/16"		4pcs
8	Wood Screw	Ø8 x 50 mm		6pcs

Screw driver is require for assembly (not included)

Reminders

1. Use only the hardware supplied.
2. Once the chair is finished, level and tighten all the bolts.
3. Do not over-tighten bolts.
4. This item may require periodic tightening.

NOTE :

1. Hardware pack is located underneath the Wooden Seat (B).
2. Two or more people are needed for assembly. Please keep all hardware parts out of the reach of children.

ASSEMBLY INSTRUCTIONS

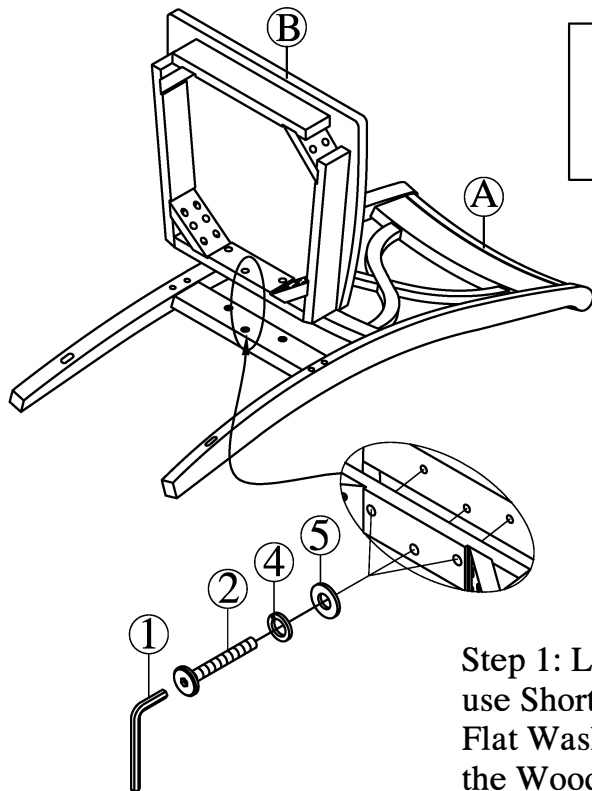

Grab hardware bag from underneath the Wooden Seat.
Do not fully tighten bolts until the Product is level
and the assembly of the product is completed.

Fig.1

Step 1: Lay the Backrest (A) on a flat soft surface,
use Short Bolt (2), Spring Washer (4),
Flat Washer (5) and Allen Key (1) to attached
the Wooden Seat (B) to Backrest (A) as shown in Fig. 1.

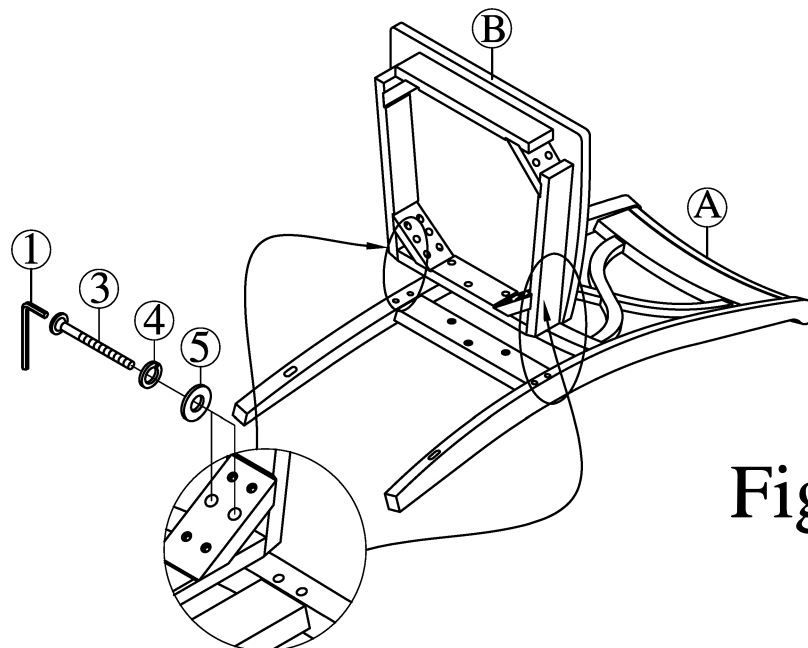

Fig.2

Note: move seat back
and forward to ease
the finding of the hole in
the corner block.

Step 2 : Use Long Bolt (3), Spring Washer (4)
Flat Washer (5) and Allen Key (1) to attached the Wooden Seat (B) to
Chair Backrest (A) as shown in Fig. 2 .
Do not fully tighten bolts yet.

ASSEMBLY INSTRUCTIONS

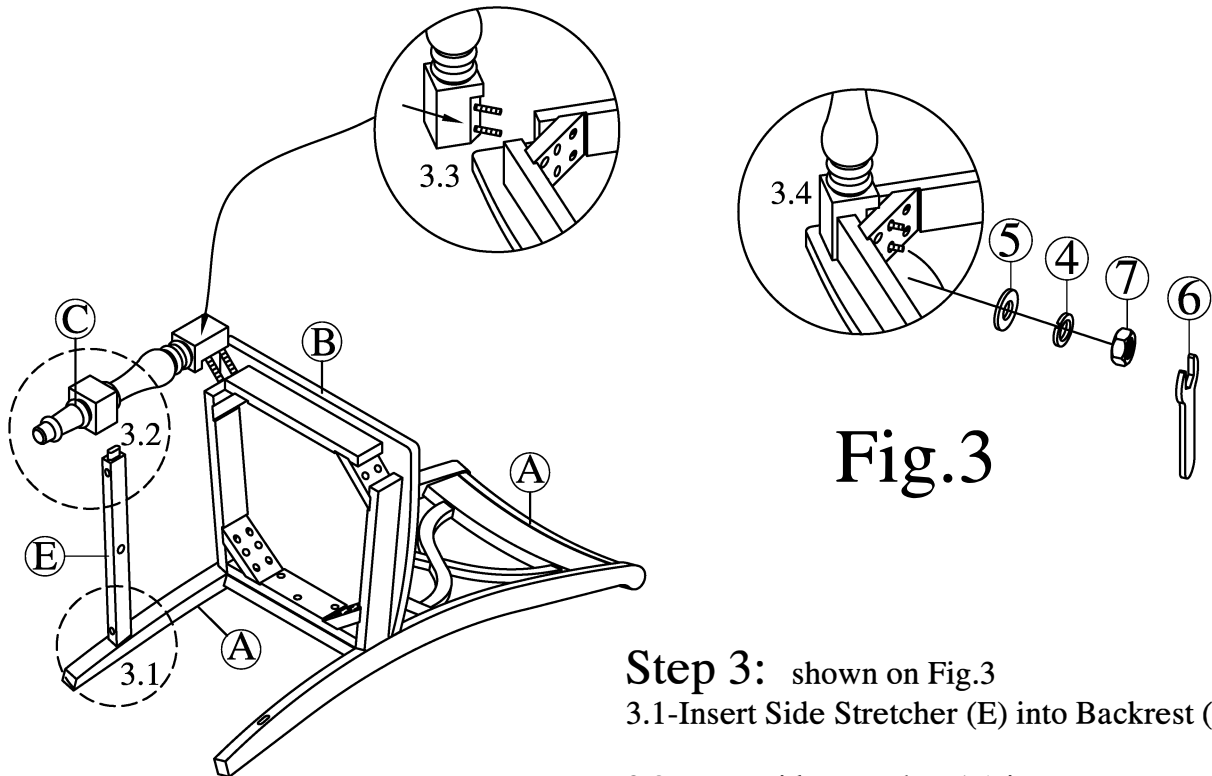

Fig.3

Step 3: shown on Fig.3

3.1-Insert Side Stretcher (E) into Backrest (A).

3.2-Insert side stretcher (E) into Front Leg (C).

3.3- Insert Front leg (C) into Wooden Seat (B).

3.4- Use Hex-Nut (7), Spring Washer (4), Flat Washer (5) and tighten with Wrench (6) to attach Front Leg (C) to Wooden Seat (B).
Do Not Fully Tighten Bolts Yet

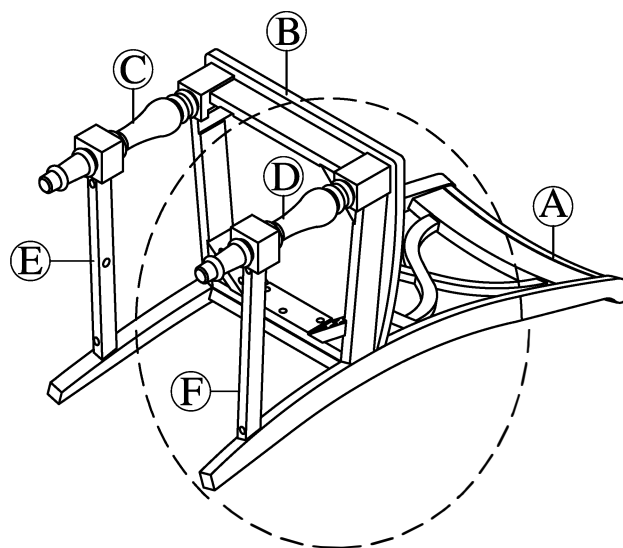

Fig.4

Step 4.

Repeat step 3 to attach the remaining Side Stretcher (F) and Front Leg (D) to Wooden Seat (B) as shown on Fig.4 .

ASSEMBLY INSTRUCTIONS

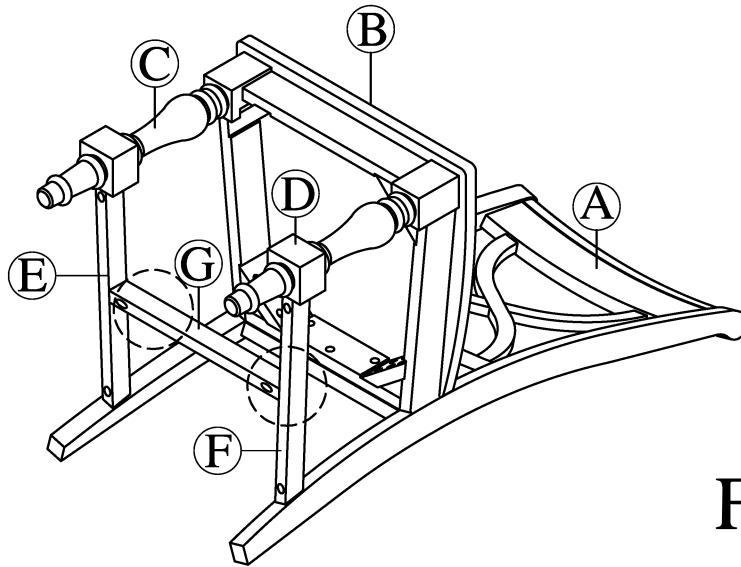

Fig.5

Step 5:
Insert Center Stretcher (G) Between side stretchers (E & F)
as shown in Fig 5.

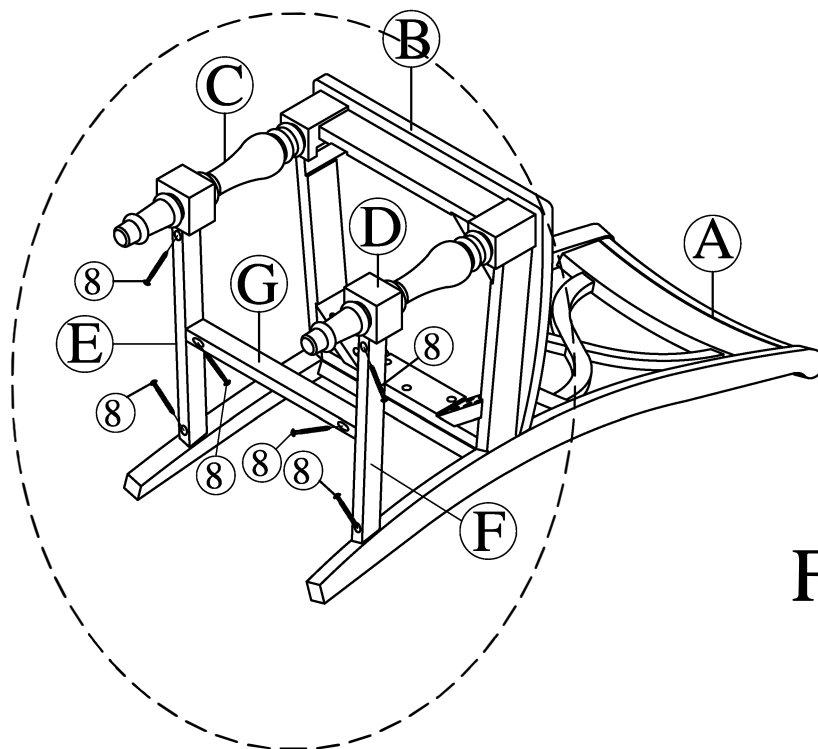

Fig.6

Step 6 : Insert Wood Screw (8) to fasten
All stretchers (E, F, G) as shown on Fig. 6

ASSEMBLY INSTRUCTIONS

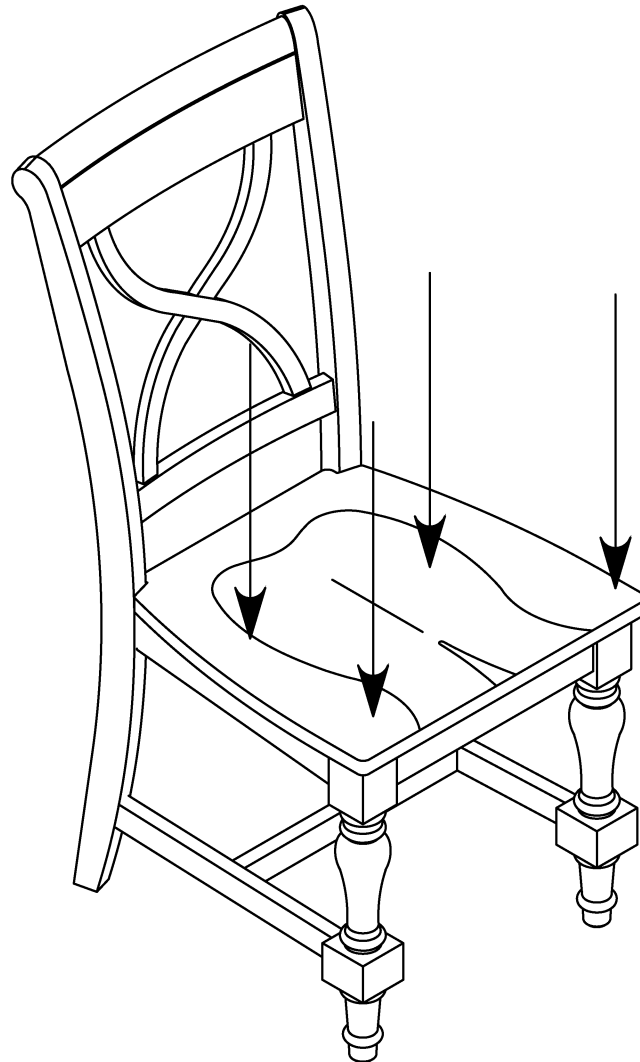

Fig.7

Step 9: Place the loosely assembled chair on a hard flat surface and apply gentle downward pressure on the seat. As shown on Fig.7. Once the chair is balanced and leveled, fully tighten all bolts.

Assembly is now Complete