

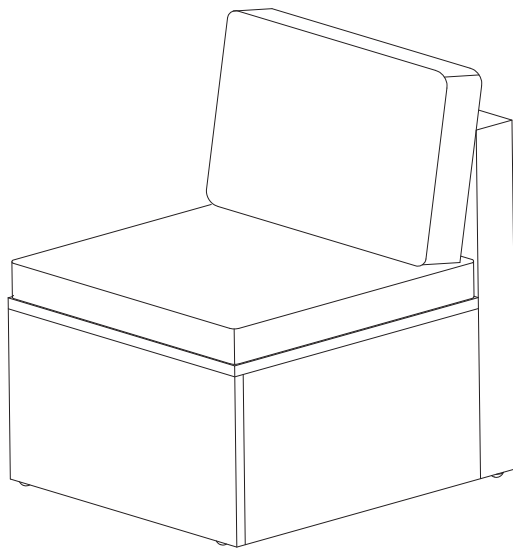

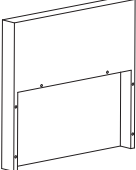







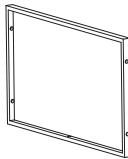
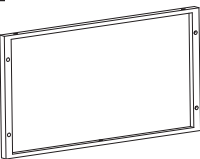

Outdoor Wicker Center Chair



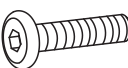
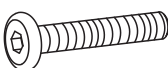
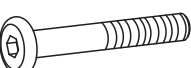

PART LIST

				
<p>Back Panel 1 PC</p>	<p>Seat Panel 1 PC</p>	<p>Side Panel 2 PCS</p>	<p>Lower Front Panel 1 PC</p>	<p>Cover of Seat Cushion * 1 PC</p>
			<p>*Please note cushion covers will ship separately.</p>	
<p>Core of Seat Cushion 1 PC</p>	<p>Cover of Back Cushion * 1 PC</p>	<p>Core of Back Cushion 1 PC</p>		

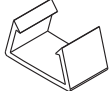
HARDWARE LIST

				
<p>M6*30mm</p> <p>Short Bolt 7 PCS</p>	<p>M6*40mm</p> <p>Medium Bolt 4 PCS</p>	<p>M6*50mm</p> <p>Long Bolt 2 PCS</p>	<p>M6mm</p> <p>Nut 6 PCS</p>	<p>M6mm</p> <p>Washer 19 PCS</p>
				
<p>M6mm</p> <p>Wrench 1 PC</p>	<p>M6mm</p> <p>Allen Key 1 PC</p>	<p>M6mm</p> <p>Adjustable Leveler 4 PCS</p>	<p>Plastic Clip 2 PCS</p>	

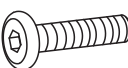
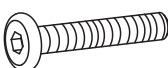
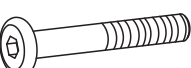
EXTRA HARDWARE LIST

				
<p>M6*30mm</p> <p>Short Bolt 2 PCS</p>	<p>M6*40mm</p> <p>Medium Bolt 1 PC</p>	<p>M6*50mm</p> <p>Long Bolt 1 PC</p>	<p>M6mm</p> <p>Nut 2 PCS</p>	<p>M6mm</p> <p>Washer 3 PCS</p>

Step 1. Lay back panel (part A) down on a soft flat surface, such as carpet, as shown below. Attach both side panels (part C) to back panel (part A) using medium bolts (part #2), washers (part #5), nuts (part #4), wrench (part #6) and allen key (part #7).

NOTE: Please do not fully tighten bolts until unit is fully assembled.

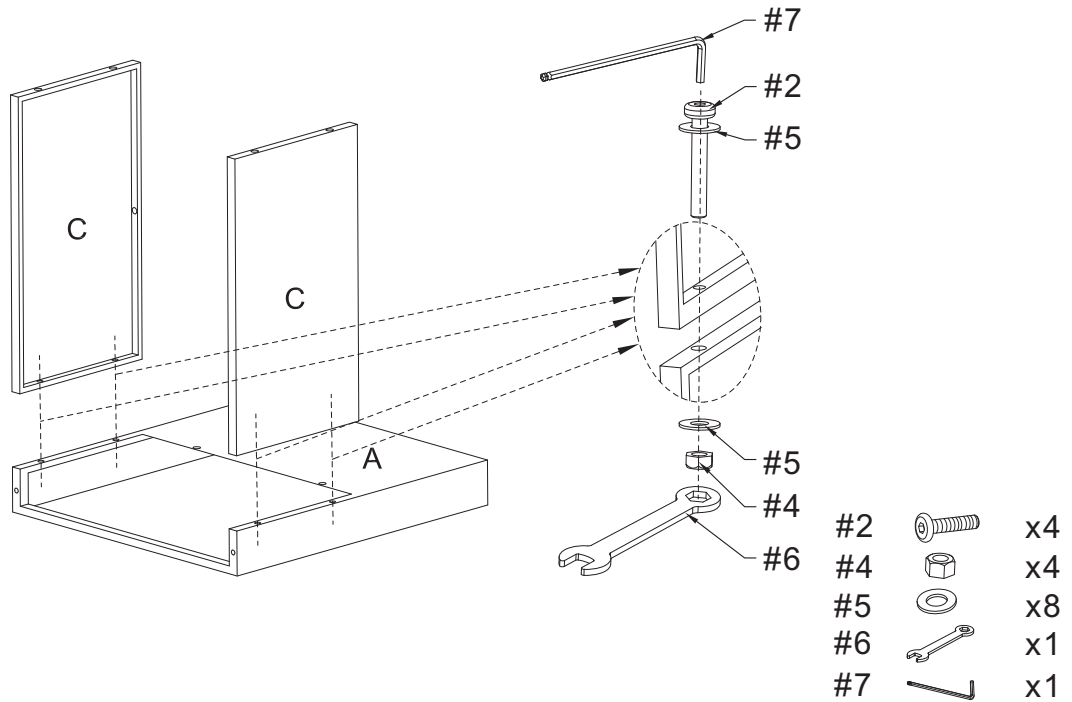

Step 2. Attach seat panel (part B) to side panels (part C) and back panel (part A) using short bolts (part #1), long bolts (part #3), washers (part #5), nuts (part #4), wrench (part #6) and allen key (part #7).

NOTE: Please do not fully tighten bolts until unit is fully assembled.

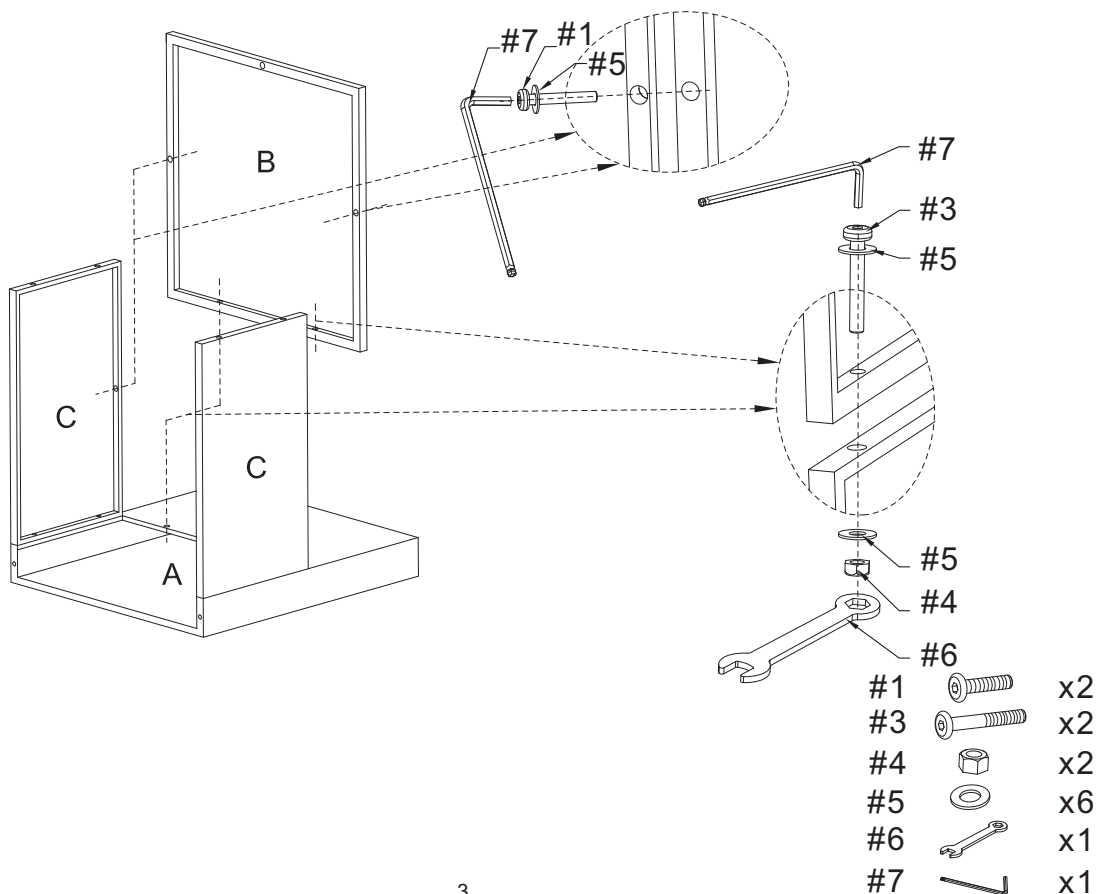

Step 3. Attach lower front panel (part D) to side panels (part C) and seat panel (part B), using short bolts (part E), washers (part #5) and allen key (part #7).

NOTE: Please fully tighten all bolts at this time.

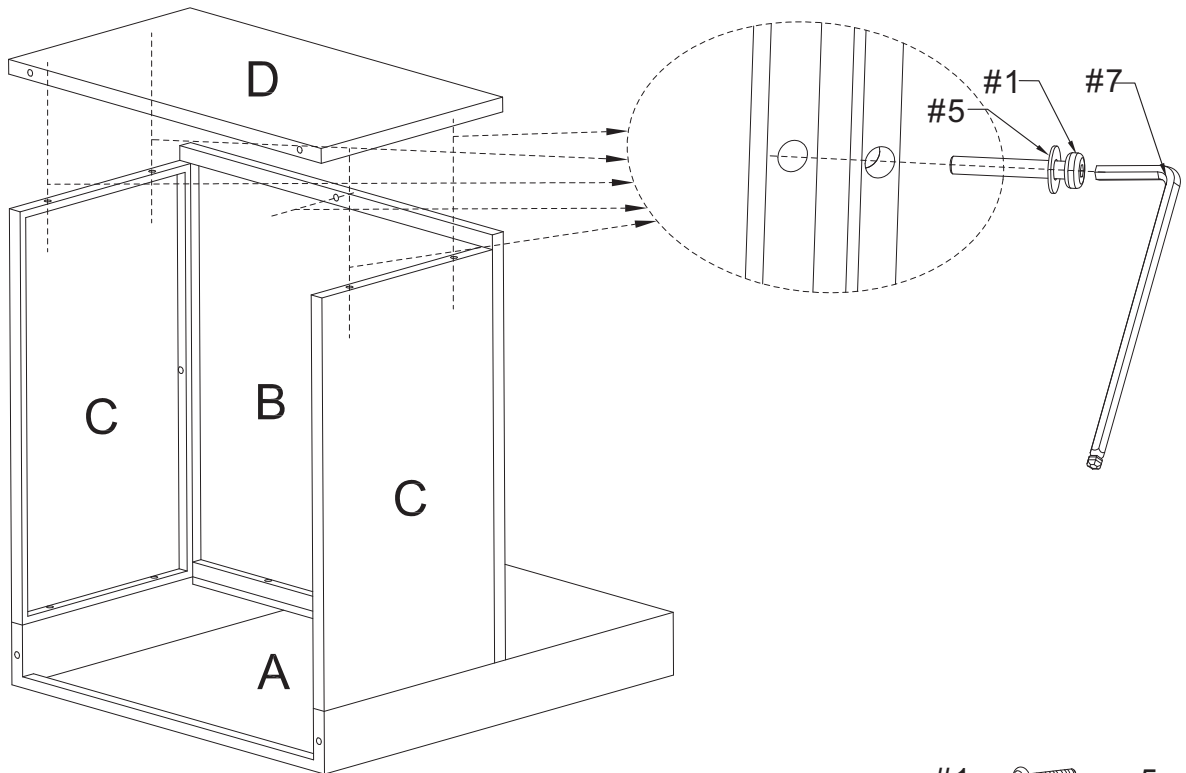

- | | | |
|----|---|----|
| #1 |  | x5 |
| #5 |  | x5 |
| #7 |  | x1 |

Step 4. Screw adjustable levelers (part #8) to desired position in the pre-drilled holes on the bottom of the chair where shown.

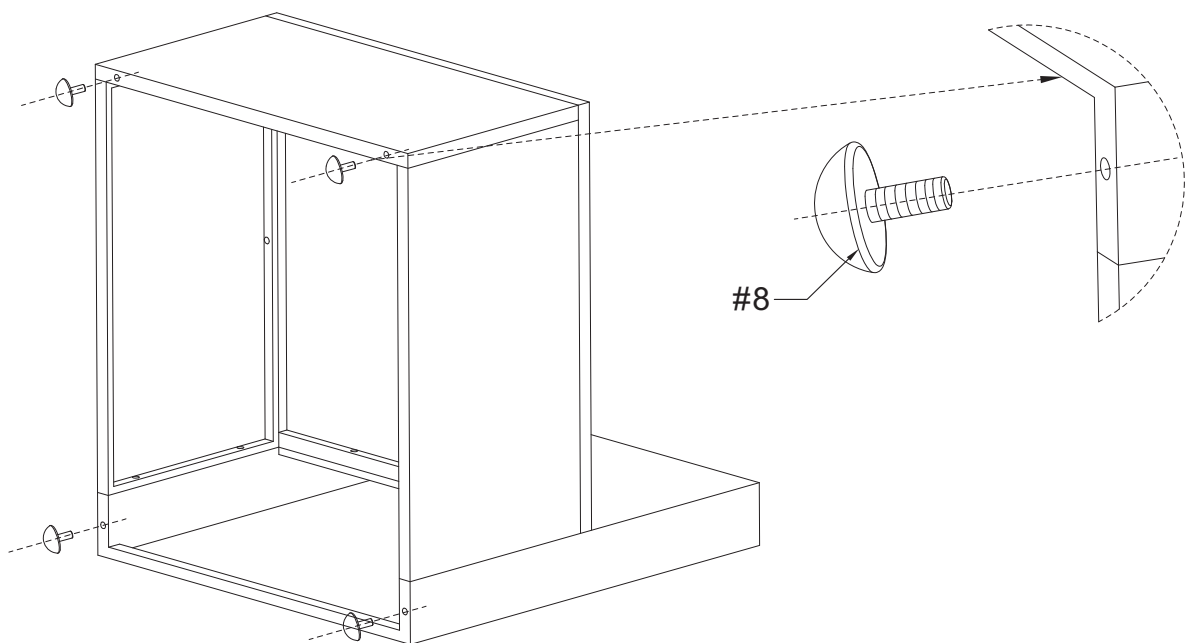

- | | | |
|----|---|----|
| #8 |  | X4 |
|----|---|----|

Step 5. Insert core of seat cushion (part F) into cover of seat cushion (part E).
Insert core of back cushion (part H) into cover of back cushion (part G).

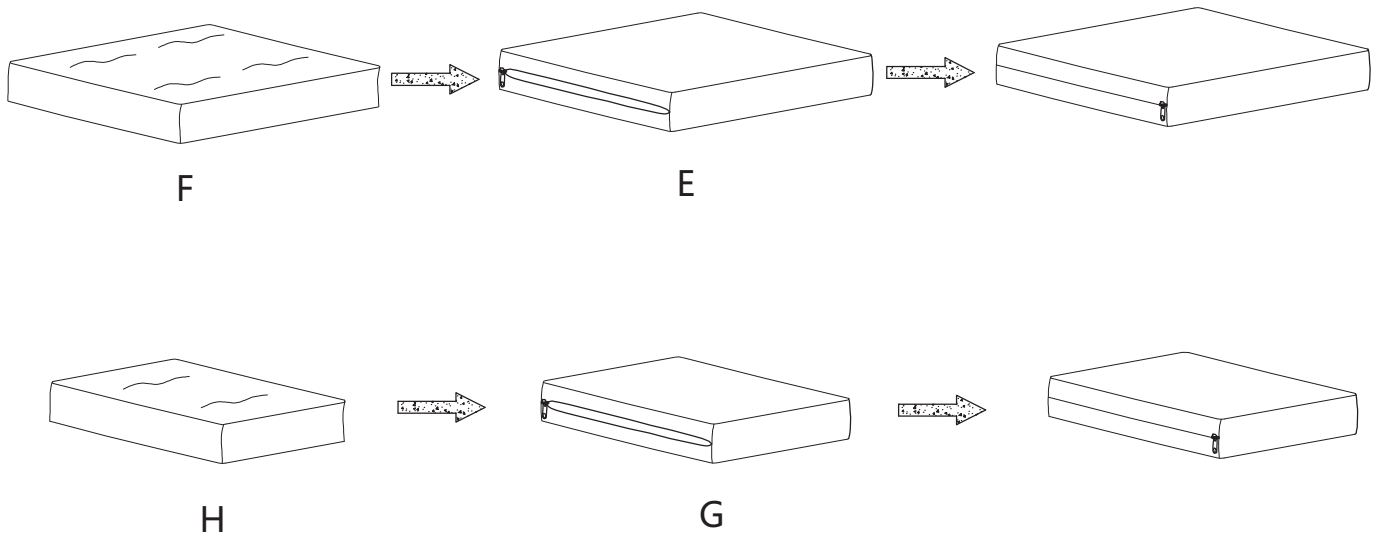

Step 6. Carefully turn the assembled chair upright and add cushions as shown below.

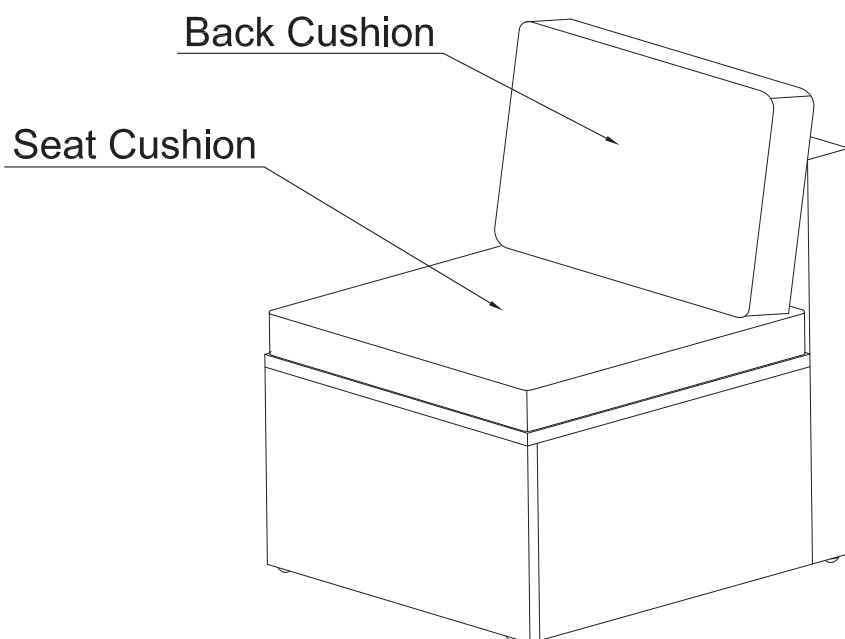

Step 7. Use plastic clips (part #9) to secure additional units together as shown.

