

# Assembly Guide

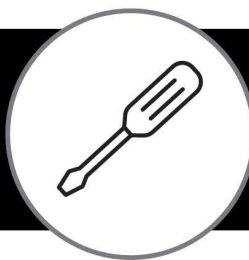

**If you're having any difficulty during assembly of this product, don't hesitate to call us**

Our customer service experts are trained to provide step-by-step instruction and can easily replace any missing or damaged parts.

## 2 Drawer Mobile Pedestal

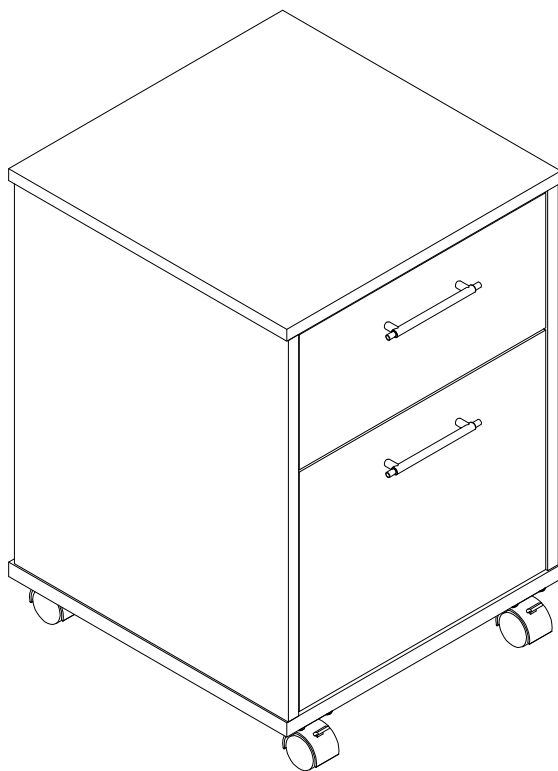

# Get Ready to Assemble

## For best results, keep these tips in mind:

- ① We know you want to finish this assembly as quickly as possible, but trust us: you'll have a better experience if you take it one step at a time.
- ② Give yourself some room to work near where you want the fully assembled product.
- ③ If your floor isn't carpeted, assemble this product on the empty carton to avoid scratching.
- ④ Do you have a friend who owes you a favor? Some steps may go a little easier with a second set of hands.

### DOs

- ✔ Use a #2 Phillips head screwdriver (or other handheld tools as indicated)
- ✔ Wear safety glasses at all times during assembly
- ✔ Carefully follow the instructions in this guide and complete all steps in order
- ✔ Give us a call if you're having trouble with a particularly tricky step

### DON'Ts

- ✘ We know power tools are quick and easy, but you shouldn't use them when assembling this product (unless otherwise specified)
- ✘ Never move your furniture with items inside or resting on the surface
- ✘ Do not attempt to use this product before all steps have been completed

# IMPORTANT SAFETY INFORMATION



## PLEASE READ WARNINGS

Improper use can cause safety hazards, or damage to your furniture and household items.

Warning	Do	Don't	Why it's important
<b>Serious injury may occur.</b>	<ul style="list-style-type: none"><li>Assemble following all instructions using all indicated parts and hardware provided.</li><li>Install every indicated nail and/or screw.</li><li>Verify furniture is stable on it's own.</li><li>Place heaviest items in the lower drawers.</li><li>Always load the bottom drawer first.</li></ul>	<ul style="list-style-type: none"><li>Do not move unit when loaded.</li><li>Do not load with a television or other heavy equipment.</li><li>Never exceed the maximum load limits stated in the instructions.</li></ul>	Improper assembly, use or loading can lead to product instability, tip-over or collapse.

Caution	Do	Don't	Why it's important
<b>Injury may occur.</b>	<ul style="list-style-type: none"><li>Unload unit prior to moving starting with top drawer first.</li></ul>	<ul style="list-style-type: none"><li>Do not move unit when loaded.</li></ul>	Loaded units are heavy and are not designed to be moved when loaded.

# IMPORTANT SAFETY INFORMATION



## PLEASE READ WARNINGS

Improper use can cause safety hazards, or damage to your furniture and household items.

Advertencia	Hacer	No	Por qué es importante
<b>Se pueden producir lesiones graves.</b>	<ul style="list-style-type: none"><li>• Ensamble siguiendo todas las instrucciones utilizando todas las piezas y ferretería indicados provistos.</li><li>• Instale todos los clavos y / o tornillos indicados.</li><li>• Verifique que los muebles sean estables por sí mismos.</li><li>• Coloque los artículos más pesados en los cajones inferiores.</li><li>• Siempre cargue primero el cajón inferior.</li></ul>	<ul style="list-style-type: none"><li>• No cargue con un televisor u otro equipo pesado.</li><li>• No exceda los límites máximos de carga establecidos en las instrucciones.</li><li>• No permita que los niños se paren, trepen o cuelguen de muebles.</li></ul>	El ensamblaje, uso o carga inadecuados pueden provocar inestabilidad del producto, vuelco o colapso.

Atención	Hacer	No	Por qué es importante
<b>Se pueden producir lesiones.</b>	<ul style="list-style-type: none"><li>• Descargue la unidad antes de moverla, comenzando primero con el cajón superior.</li></ul>	<ul style="list-style-type: none"><li>• No mueva la unidad cuando esté cargada.</li></ul>	Las unidades cargadas son pesadas y no están diseñadas para moverse cuando están cargadas.

# IMPORTANT SAFETY INFORMATION



## PLEASE READ WARNINGS

Improper use can cause safety hazards, or damage to your furniture and household items.

Avertissement	Faire	Ne le fais pas	Pourquoi c'est important
<b>Des blessures graves peuvent survenir.</b>	<ul style="list-style-type: none"><li>• Assemblez en suivant toutes les instructions en utilisant toutes les pièces et le matériel indiqués fournis.</li><li>• Installez tous les clous et / ou vis indiqués.</li><li>• Vérifiez que les meubles sont stables par eux-mêmes.</li><li>• Placez les objets les plus lourds dans les tiroirs inférieurs.</li><li>• Chargez toujours le tiroir inférieur en premier."</li></ul>	<ul style="list-style-type: none"><li>• Ne chargez pas avec un téléviseur ou un autre équipement lourd.</li><li>• Ne dépassez pas les limites de charge maximale indiquées dans les instructions.</li><li>• Ne laissez pas les enfants se tenir debout, grimper ou s'accrocher aux meubles.</li></ul>	Un assemblage, une utilisation ou un chargement incorrects peuvent entraîner une instabilité du produit, un renversement ou un effondrement.

Attention	Faire	Ne le fais pas	Pourquoi c'est important
<b>Des blessures peuvent survenir.</b>	<ul style="list-style-type: none"><li>• Déchargez l'unité avant de déplacer en commençant par le tiroir supérieur en premier.</li></ul>	<ul style="list-style-type: none"><li>• Ne déplacez pas l'unité lorsqu'elle est chargée.</li></ul>	Les unités chargées sont lourdes et ne sont pas conçues pour être déplacées lorsqu'elles sont chargées.

# Get to know your Boards

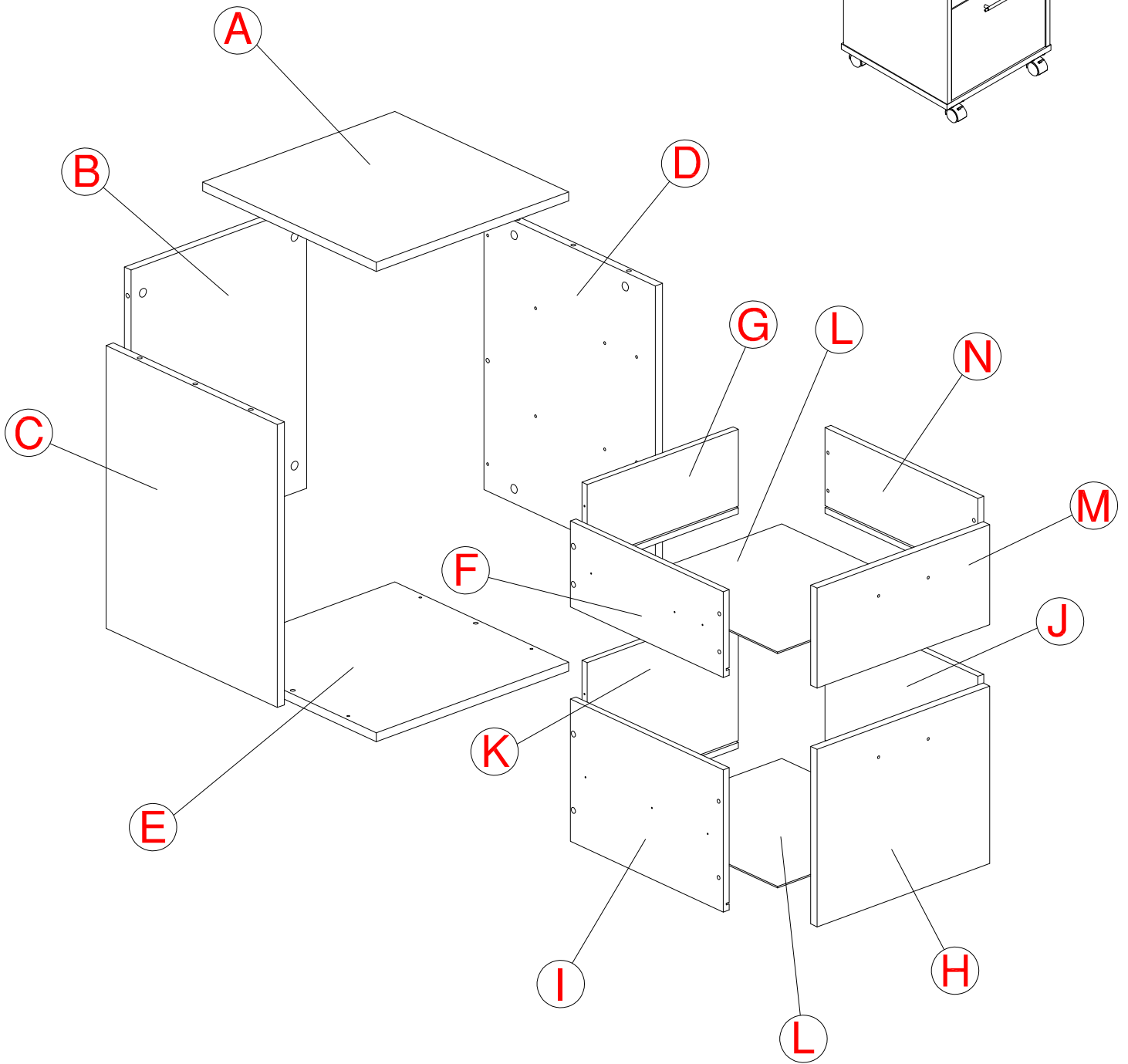
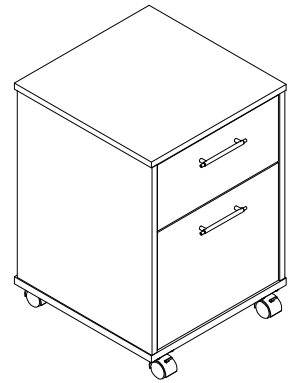

# Get to know your Fasteners

Fasteners are shown actual size.

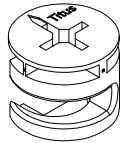

KD Cam

[ 12 ]

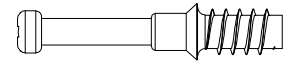

KD Bolt

[ 12 ]

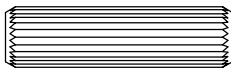

Wood Dowel  
8 x 30mm

[ 6 ]

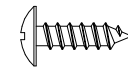

#6 x 1/2"

[ 36 ]



#6 x 1/2"

[ 12 ]

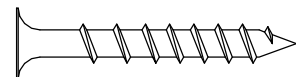

#10 x 1-1/2"

[ 8 ]

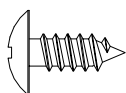

#10 x 1/2"

[ 8 ]

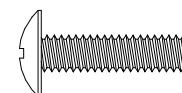

#8 x 3/4"

[ 4 ]

# Get to know your Hardware

Hardware not to scale.

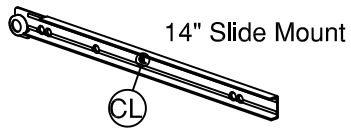

[ 1 ]

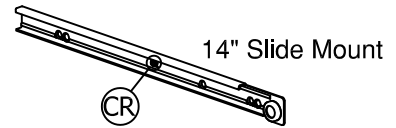

[ 1 ]

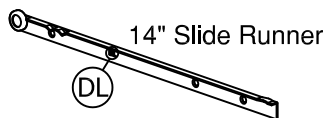

[ 1 ]

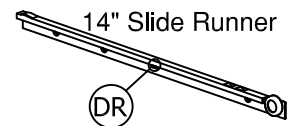

[ 1 ]

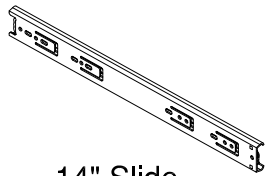

14" Slide

[ 2 ]

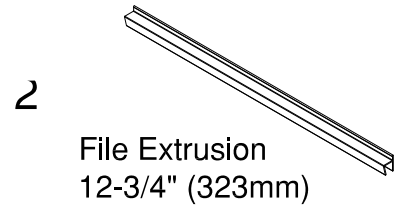

2  
File Extrusion  
12-3/4" (323mm)

[ 2 ]

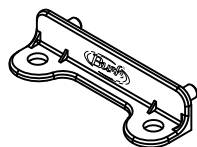

Drawer Bracket

[ 2 ]



Drawer Bracket

[ 2 ]

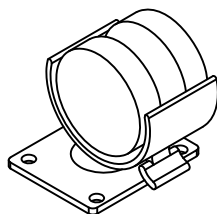

Caster, Locking

[ 2 ]

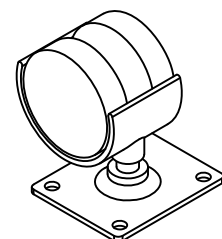

Caster

[ 2 ]

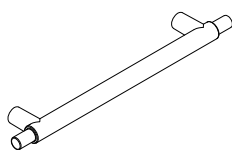

Handle

[ 2 ]

# STEP 1

# Prepare Panels

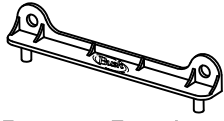

[ 2 ]

Drawer Bracket



[ 2 ]

Drawer Bracket

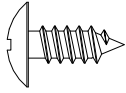

[ 8 ]

#10 x 1/2"

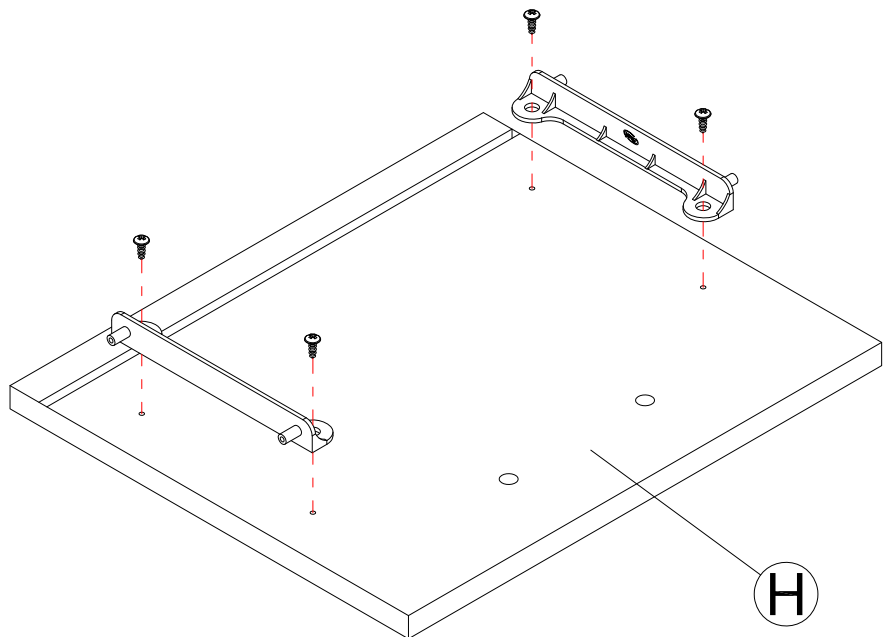
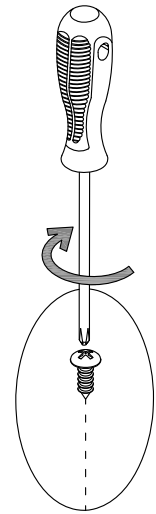
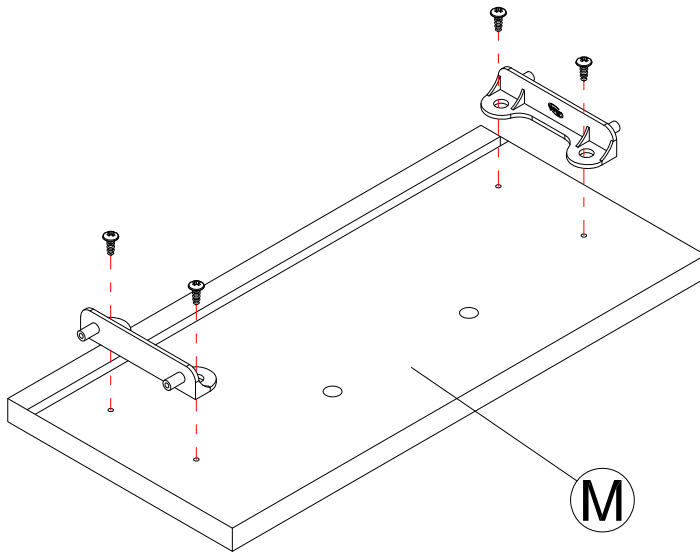

# STEP 2

# Build Drawer

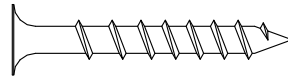
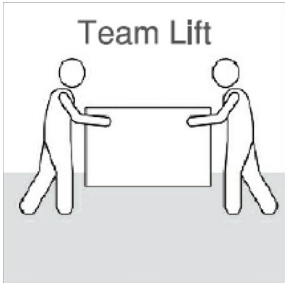

[ 4 ]

#10 x 1-1/2"



[ 2 ]

#8 x 3/4"

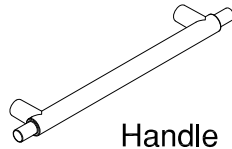

[ 1 ]

Handle

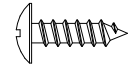

[ 4 ]

#6 x 1/2"

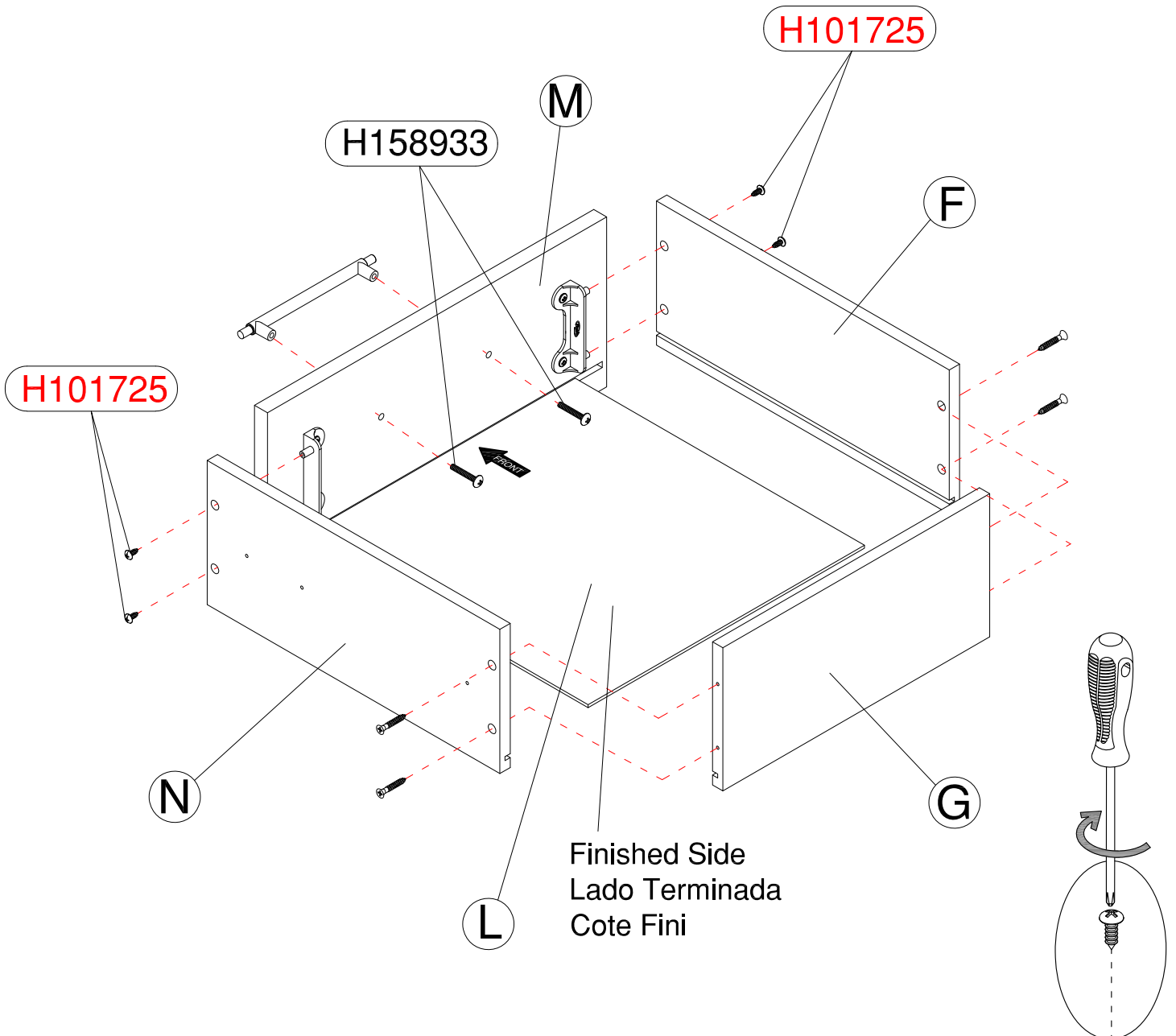



# STEP 4

# Build Drawer

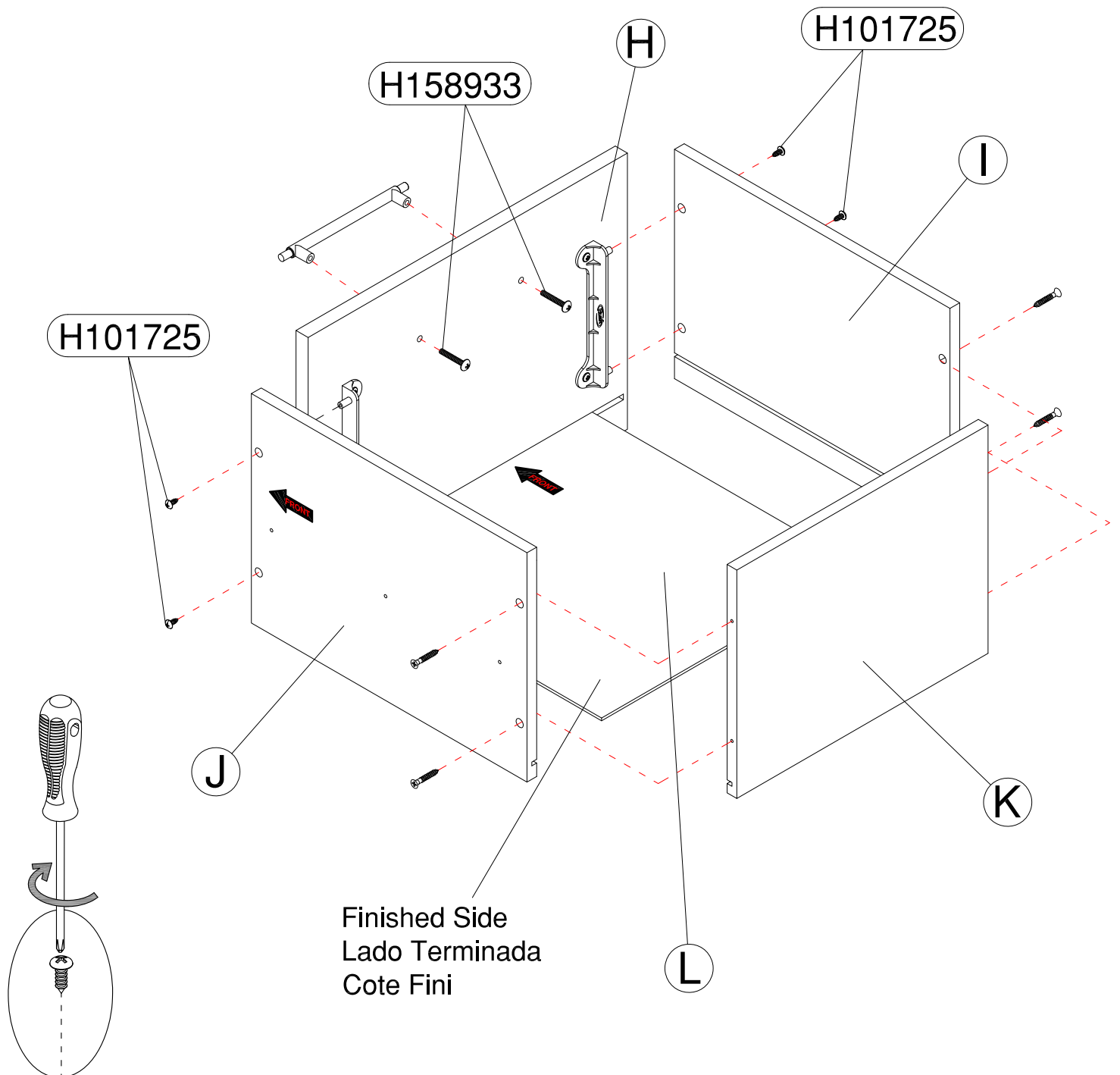
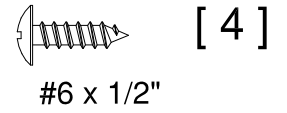
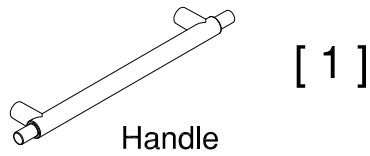
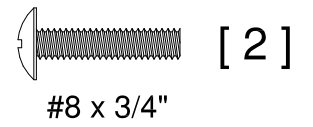
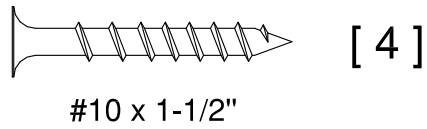
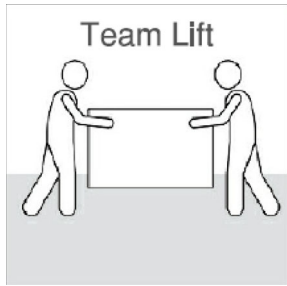

# STEP 5

# Separate Slides

**Slides Must Be Separated Before Assembly.  
After Separated, Set Aside Until Needed for Assembly.**

Las diapositivas deben separarse antes del montaje.  
Después de la separación, déjelo a un lado hasta que sea necesario.

Les glissières doivent être séparées avant l'assemblage.  
Après la séparation, mettez de côté jusqu'au moment de l'assemblage.

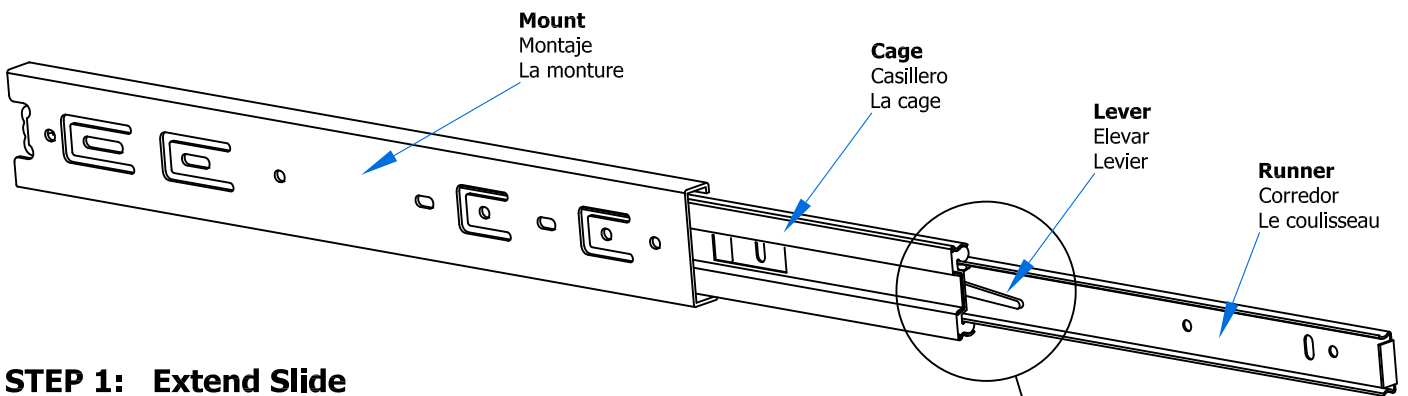

**STEP 1: Extend Slide**  
Extender la diapositiva  
Extendre la diapositive

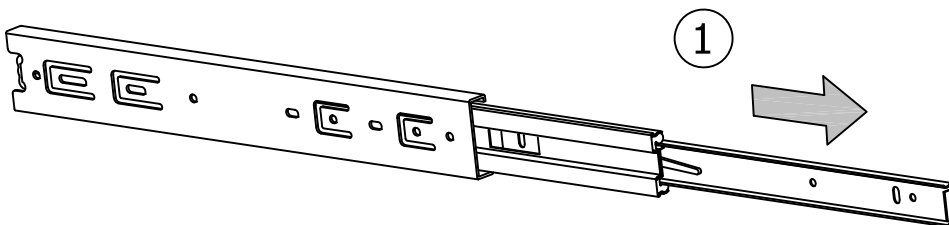

**STEP 2: Push Lever UP**  
Empujar hacia arriba  
Lever le levier

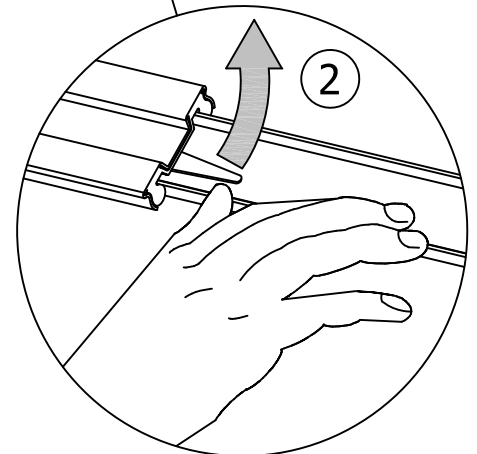

**STEP 3: Remove Runner**  
Quitar el corredor  
Enlever le coureur

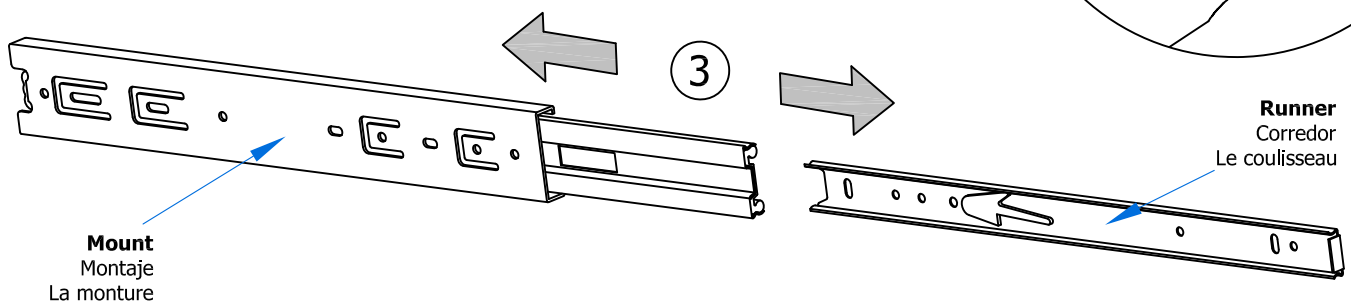

# STEP 6

# Install Slide Runners

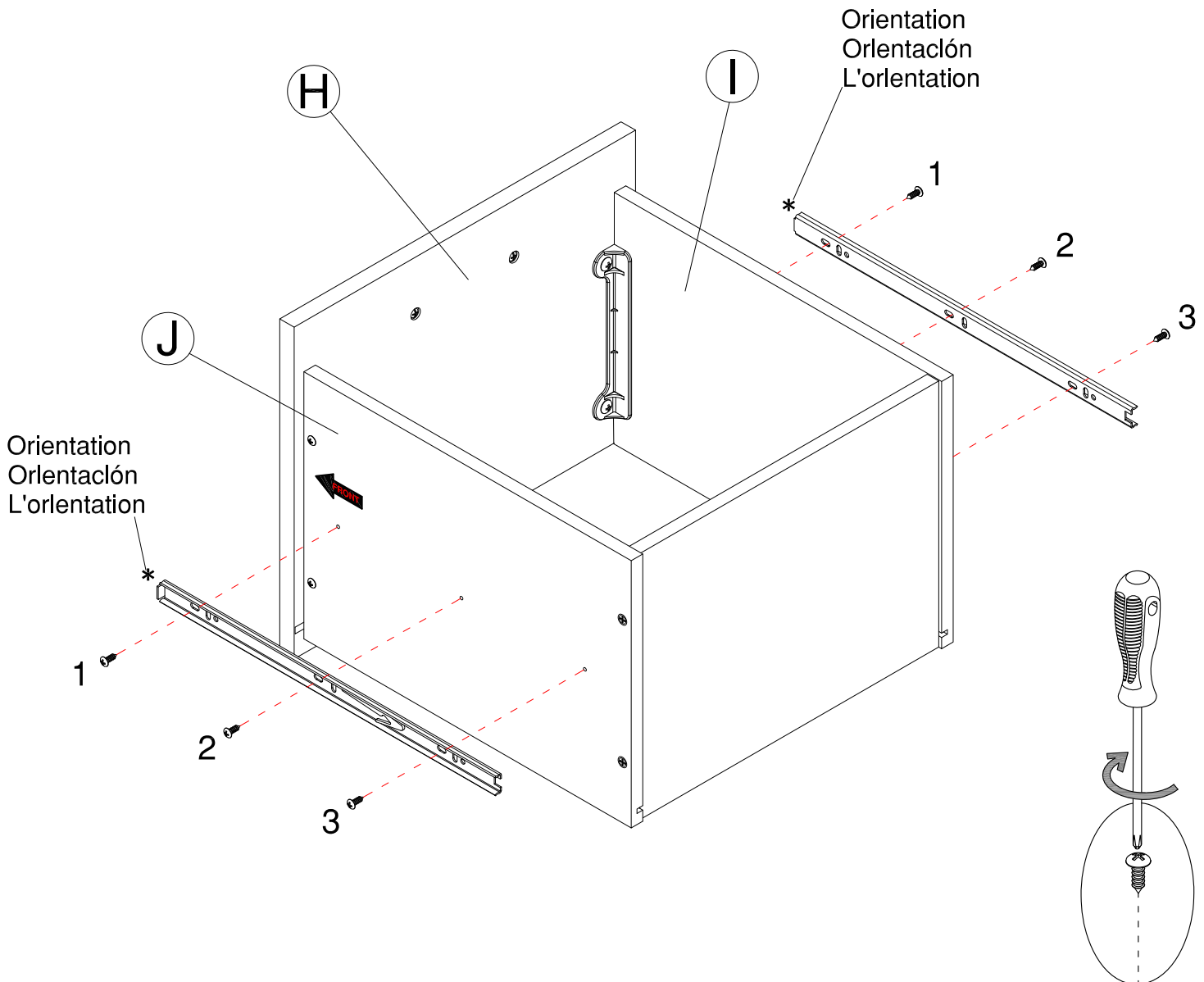
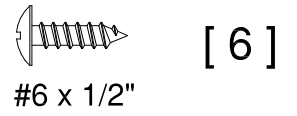
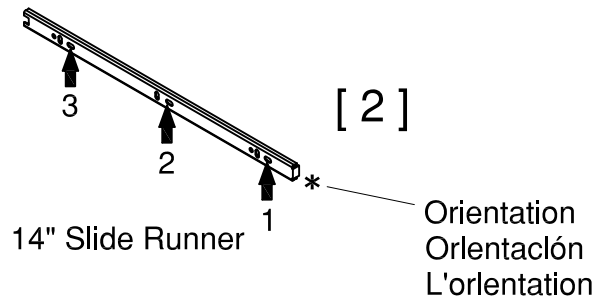

# STEP 7

# Install Hardware

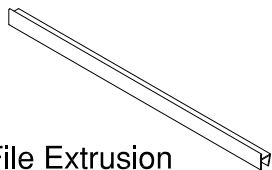

[ 2 ]

File Extrusion  
12-3/4" (323mm)

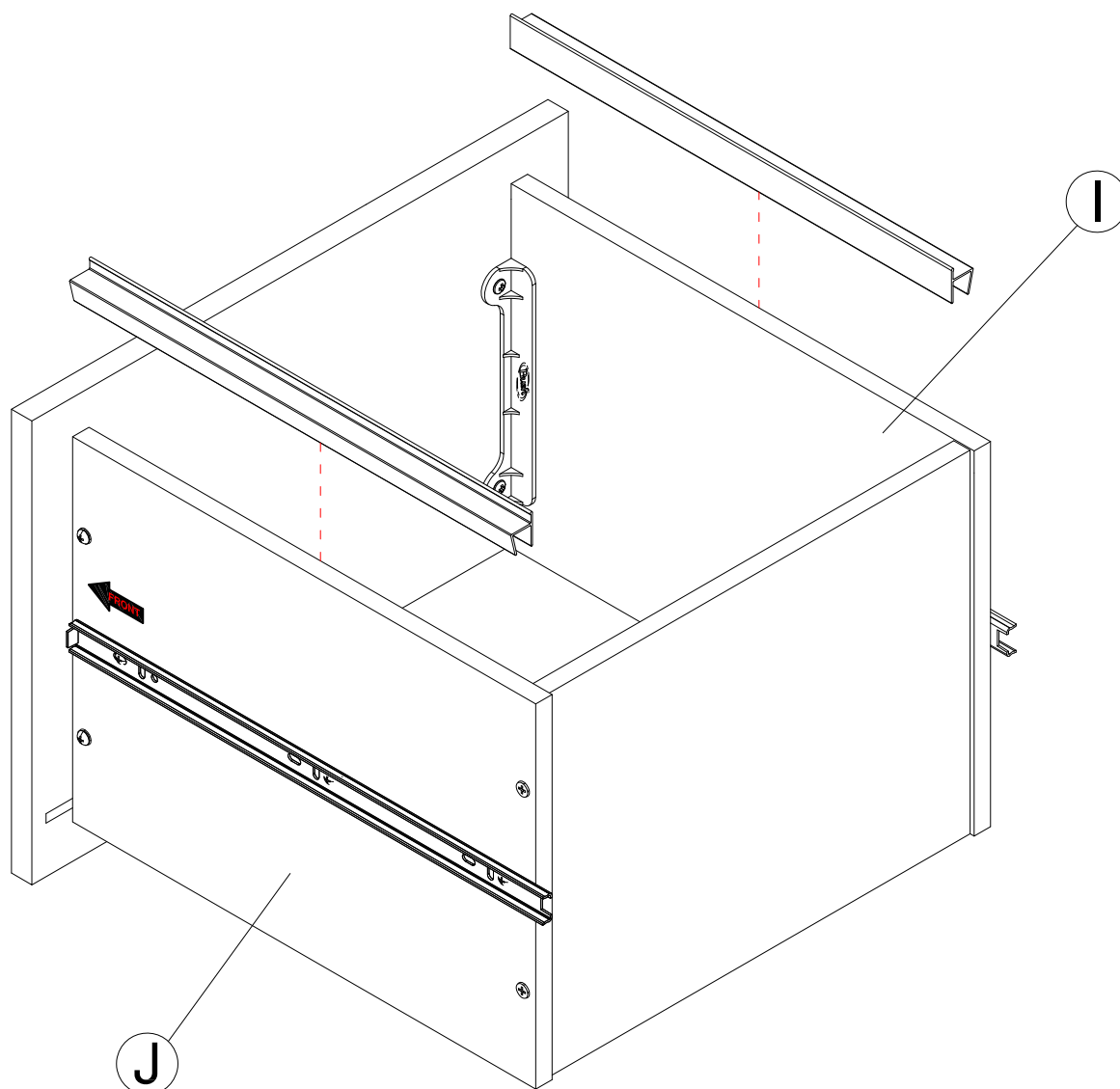

# STEP 8

# Prepare Panel

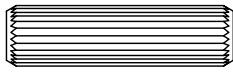

[ 2 ]

Wood Dowel  
8 x 30mm

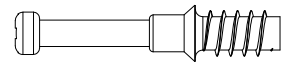

[ 2 ]

KD Bolt

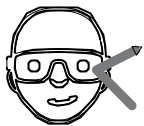
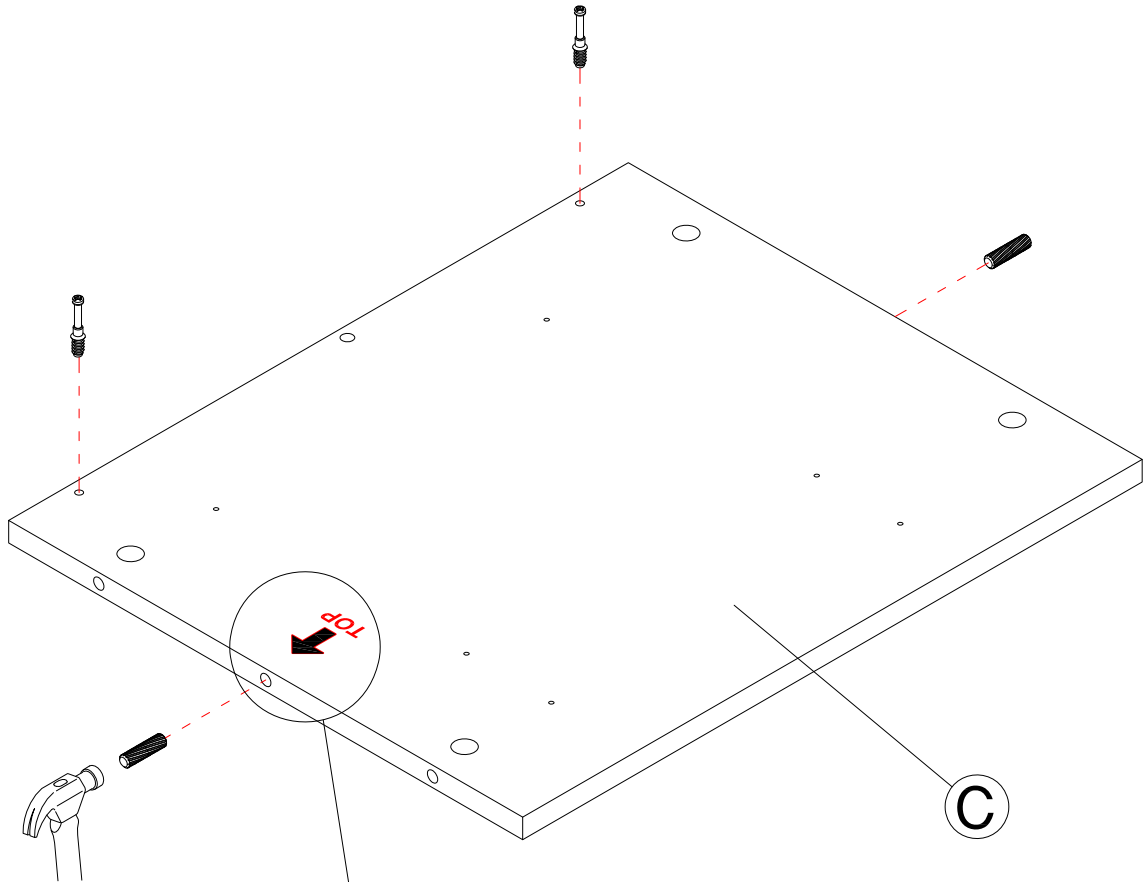
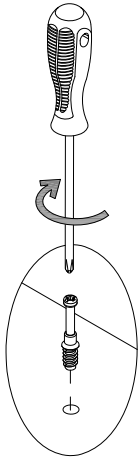

Safety glasses  
Gafas de seguridad  
Lunettes de protection

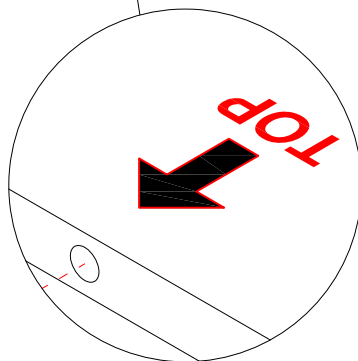

# STEP 9

# Prepare Panel

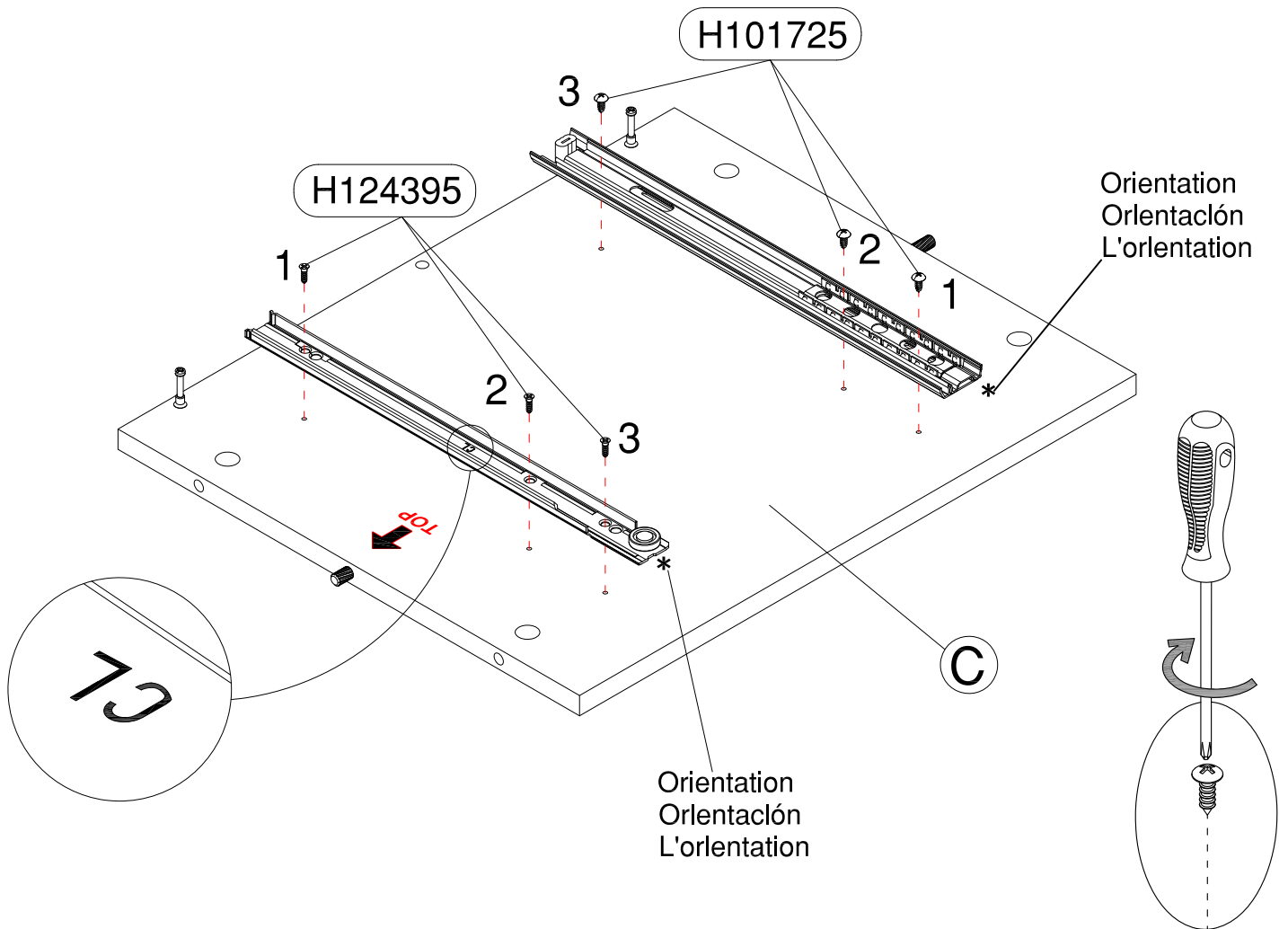
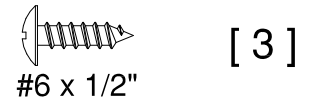
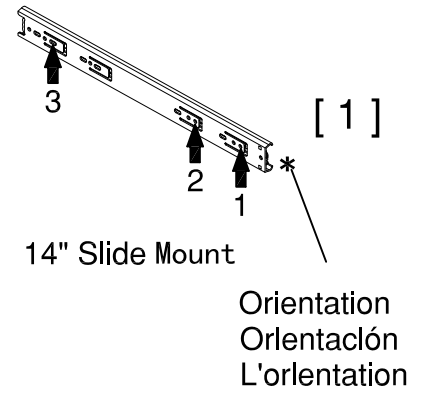
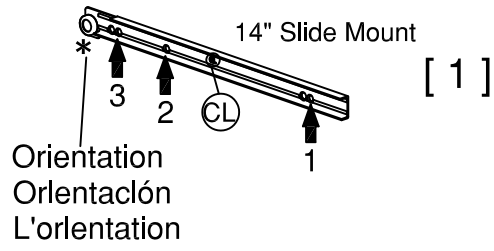

# STEP 10

# Prepare Panel

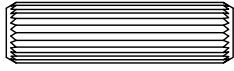

[ 2 ]

Wood Dowel  
8 x 30mm

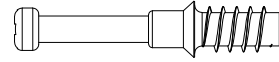

[ 2 ]

KD Bolt

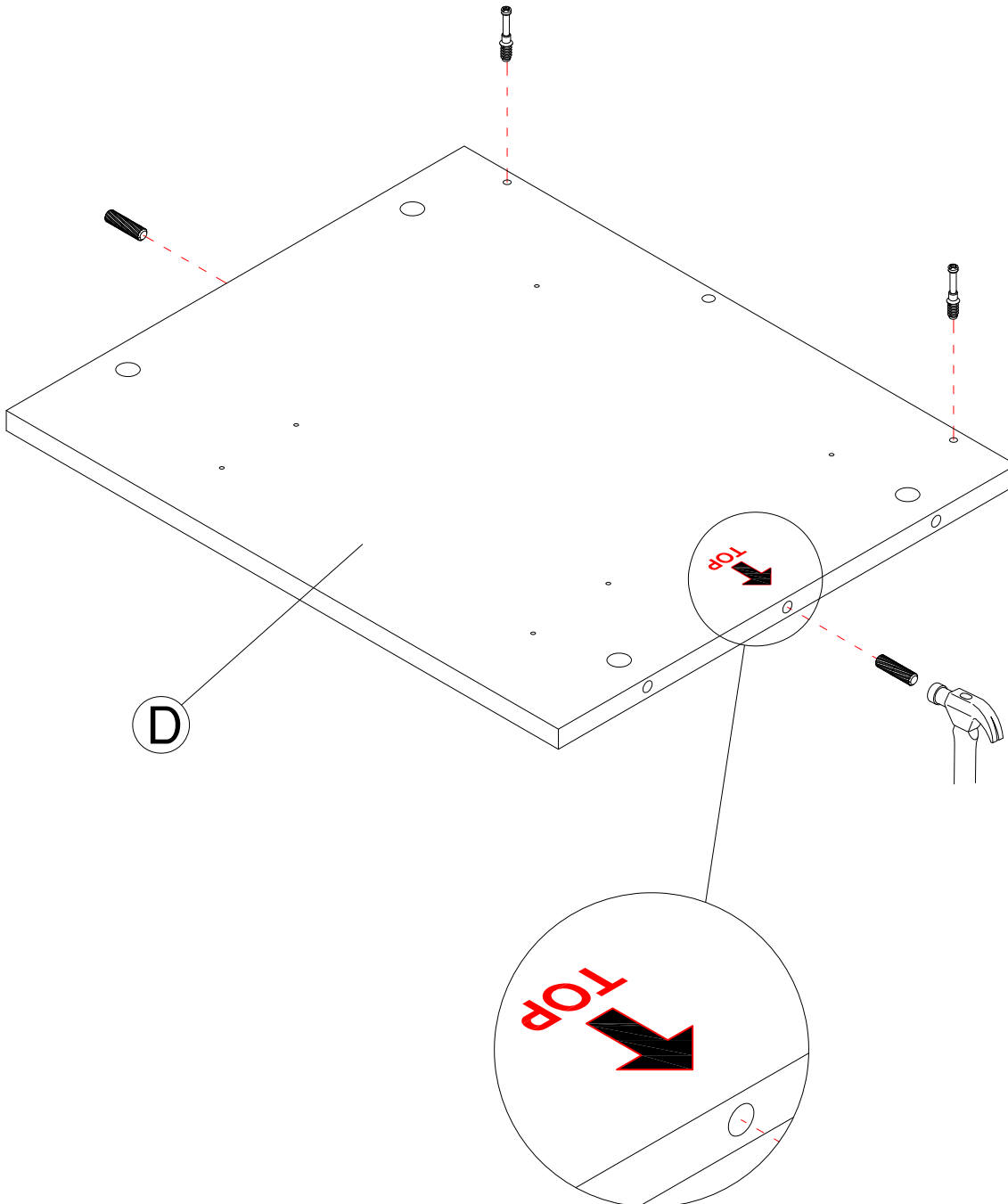

Safety glasses  
Gafas de seguridad  
Lunettes de protection

# STEP 11

# Prepare Panel

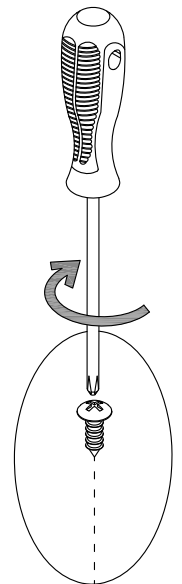
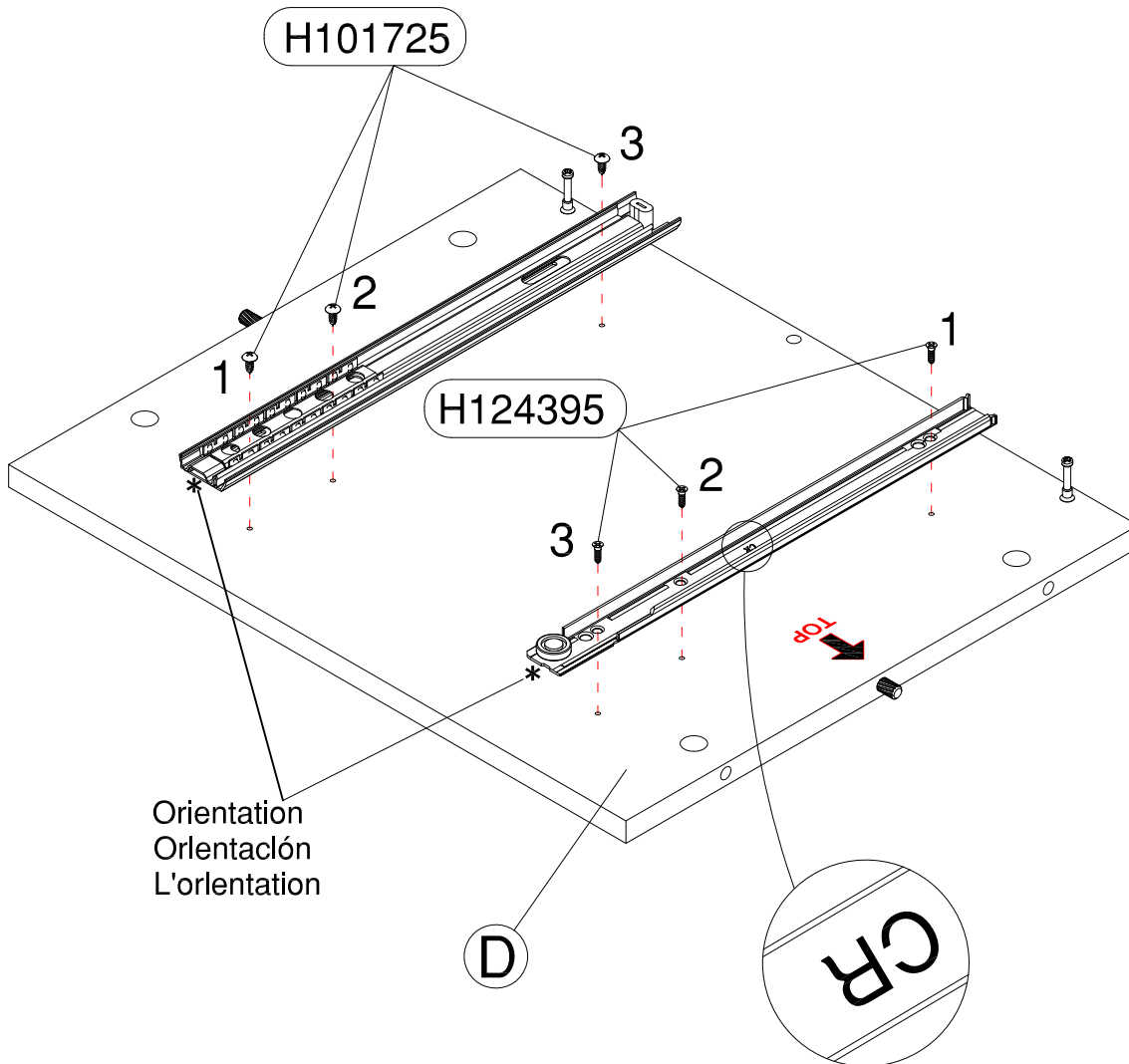
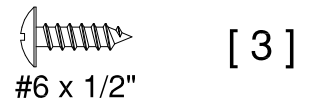
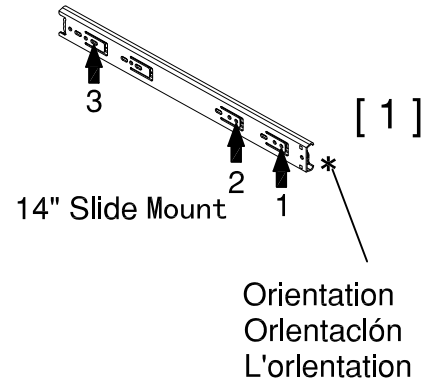
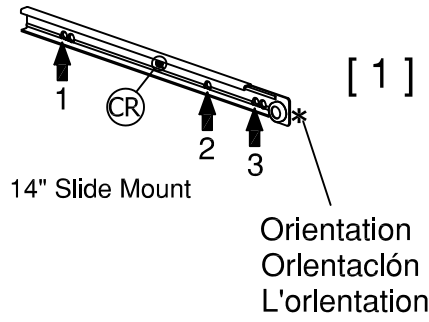

# STEP 12

# Prepare Panel



[ 2 ]

Wood Dowel  
8 x 30mm

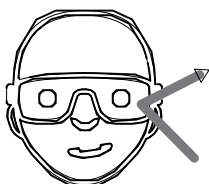
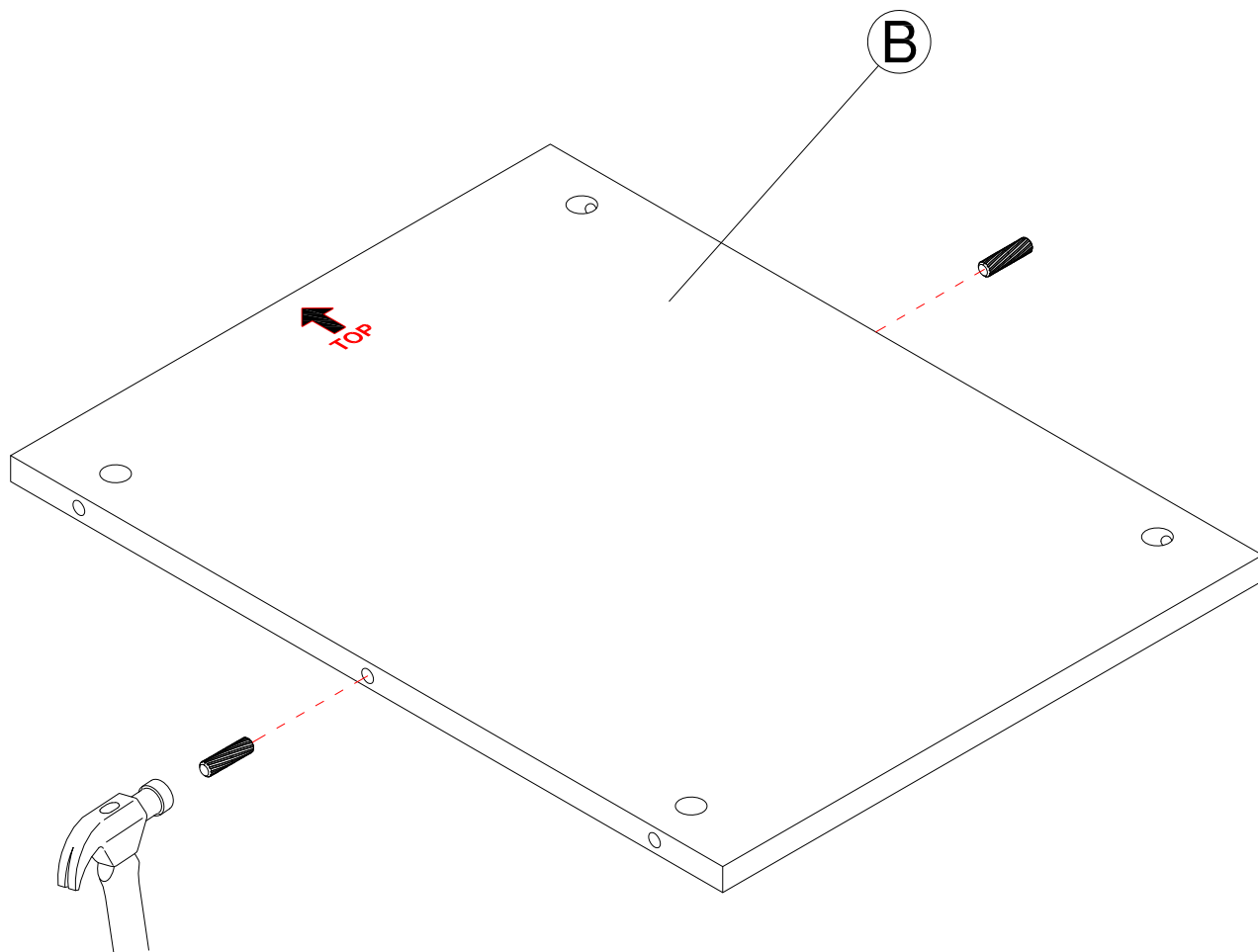

Safety glasses  
Gafas de seguridad  
Lunettes de protection

# STEP 13

# Assemble Panels

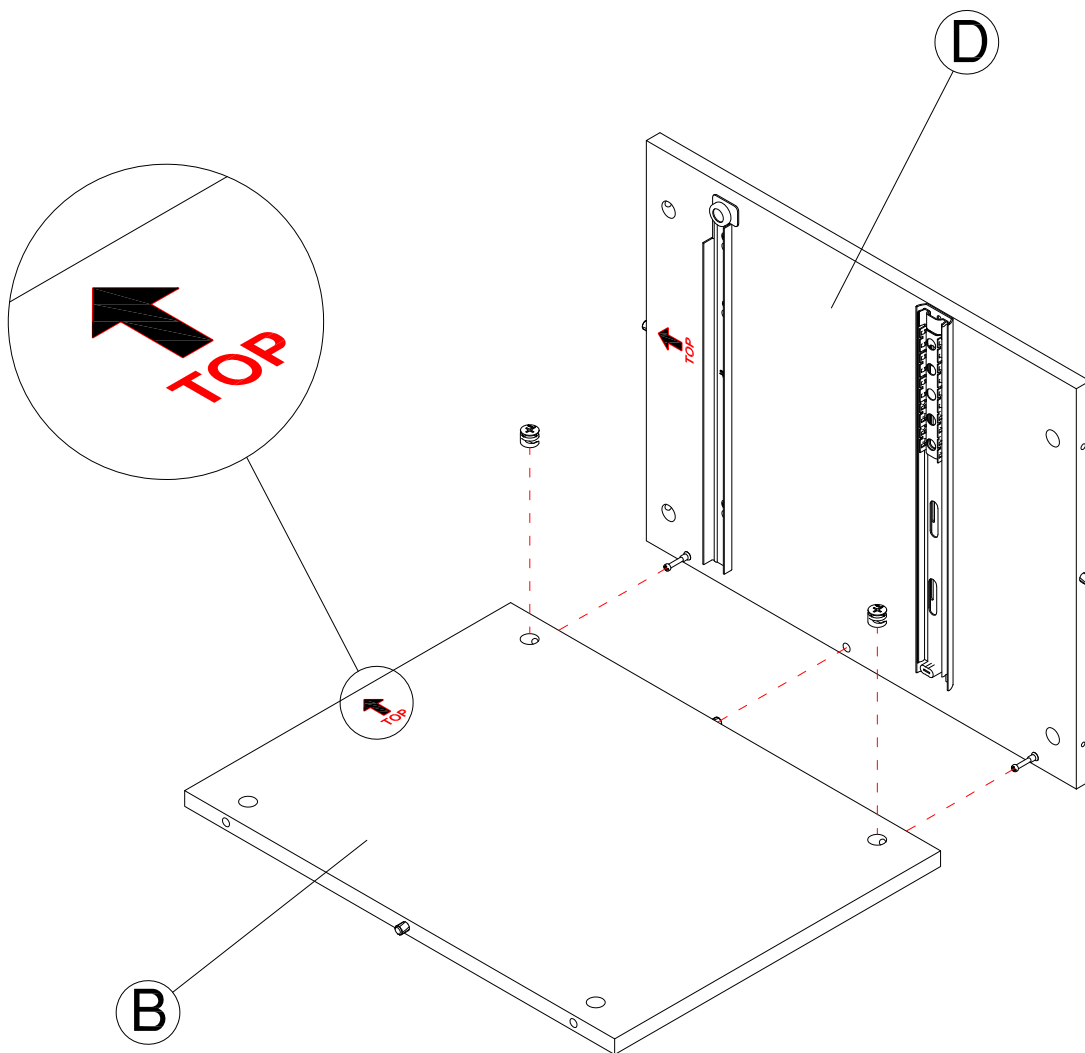
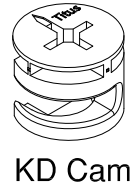
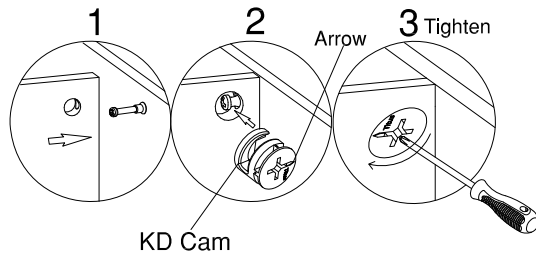

# STEP 14

# Assemble Panels

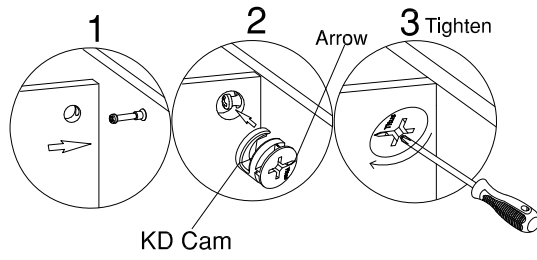

H181468

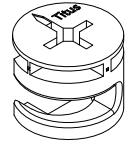

KD Cam

[ 2 ]

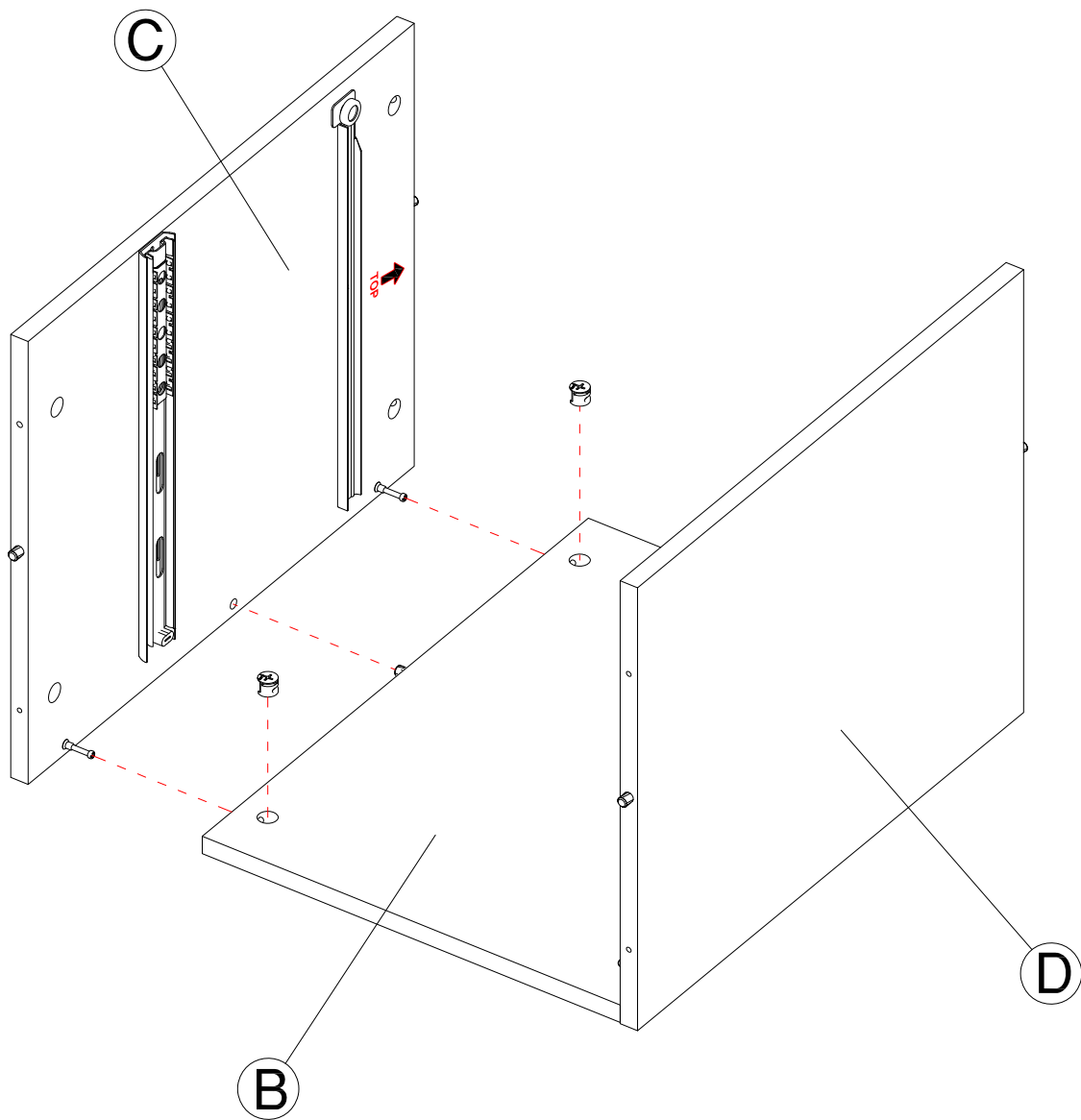

# STEP 15

# Prepare Panel

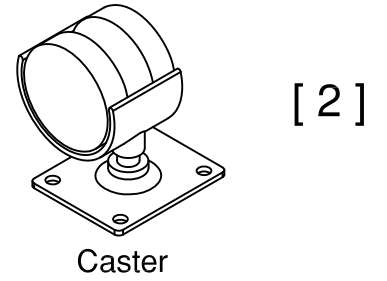
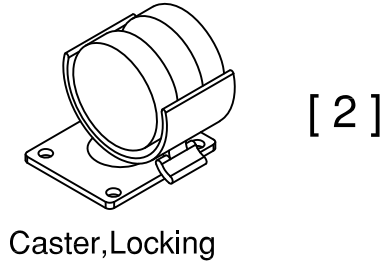
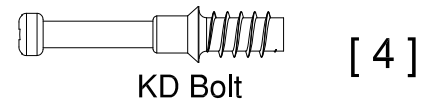
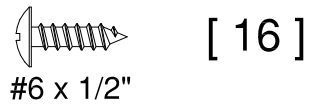

Z118862

E

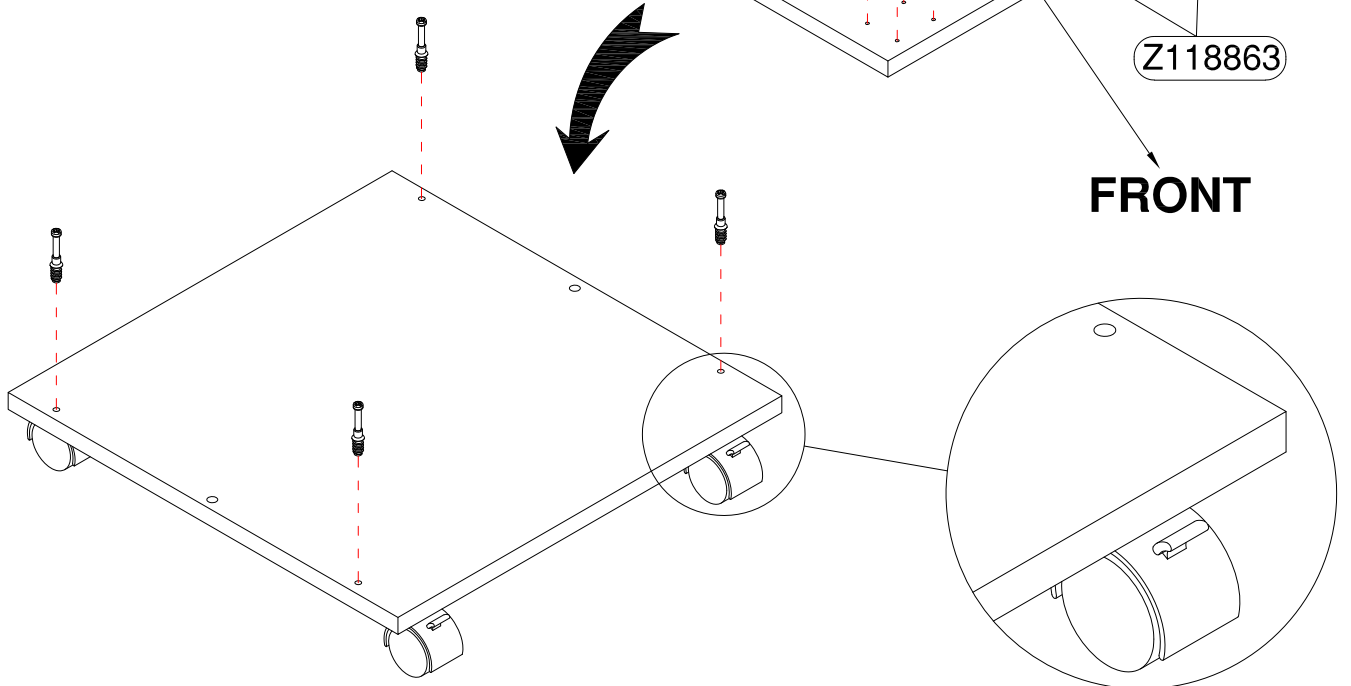
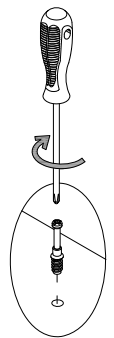
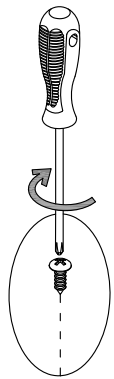
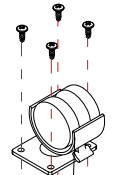
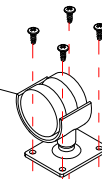
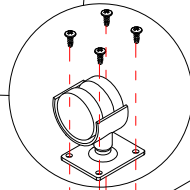
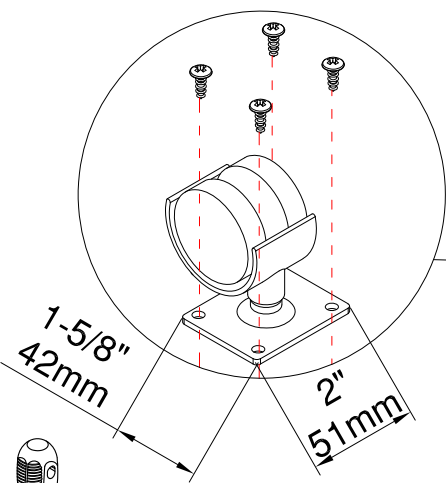

# STEP 16

# Assemble Panels

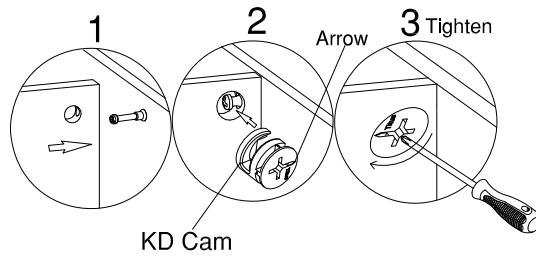

H181468

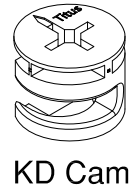

[ 4 ]

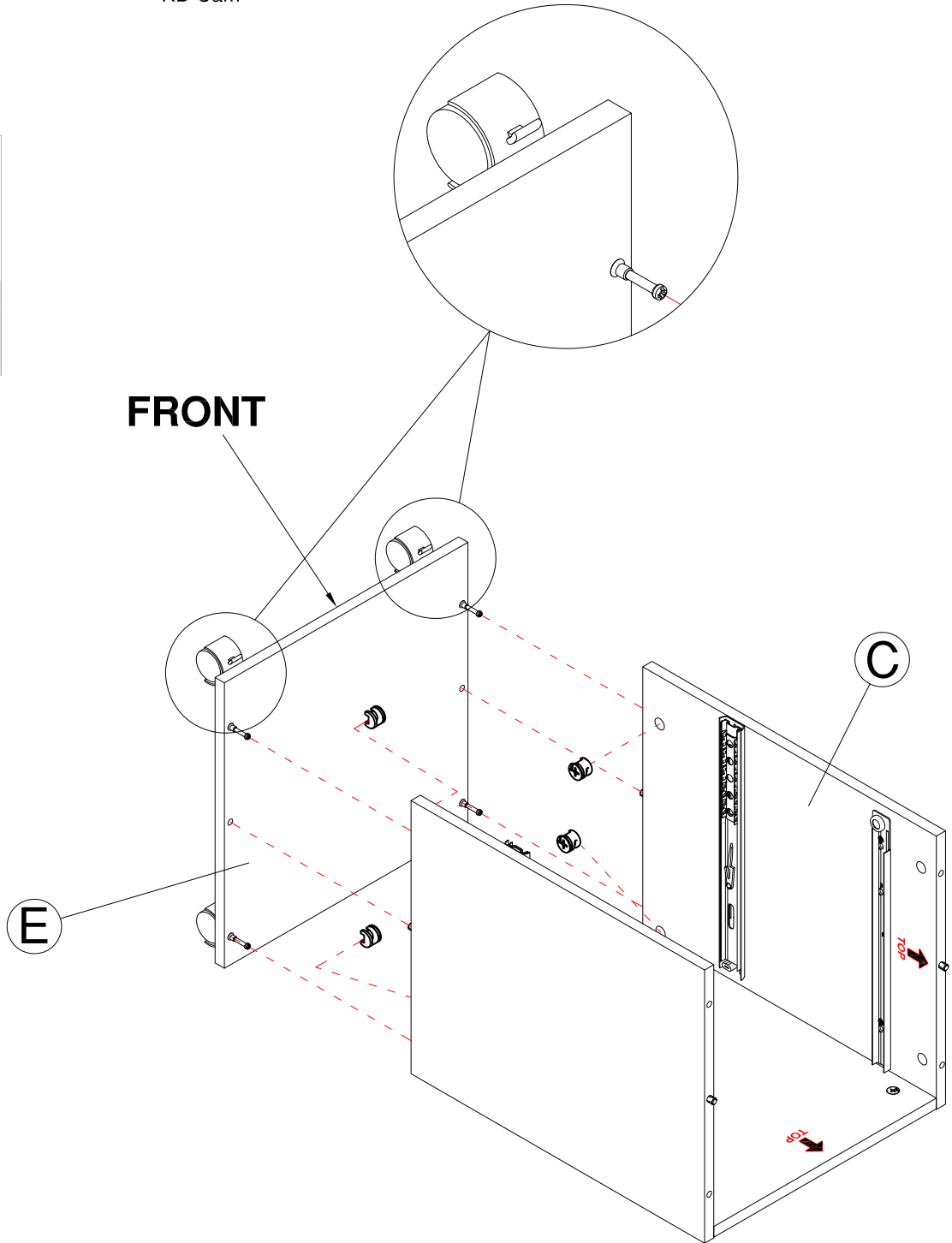
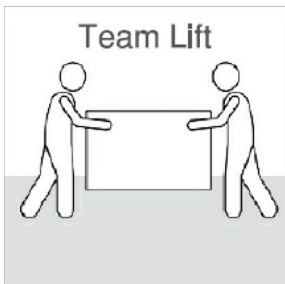

# STEP 17

# Prepare Panel

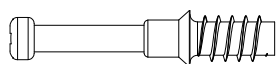

KD Bolt

[ 4 ]

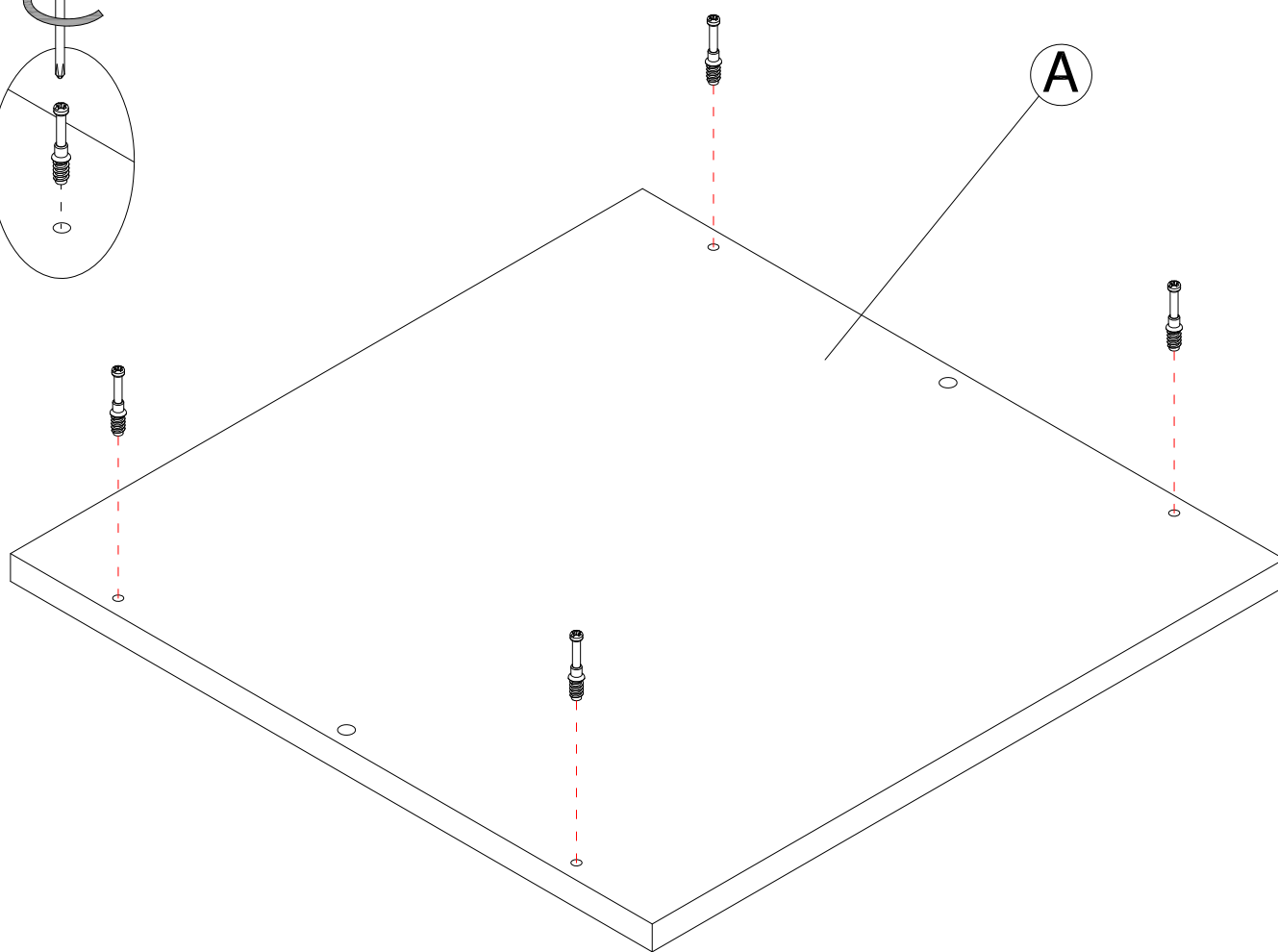
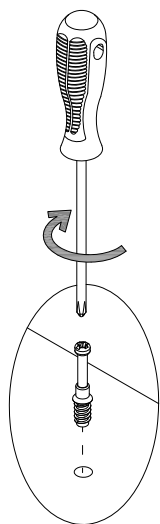

# STEP 18

# Assemble Panels

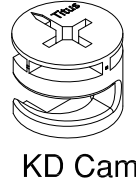
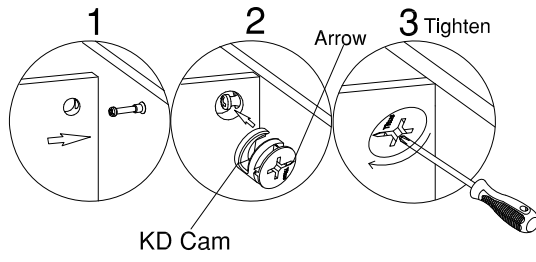

[ 4 ]

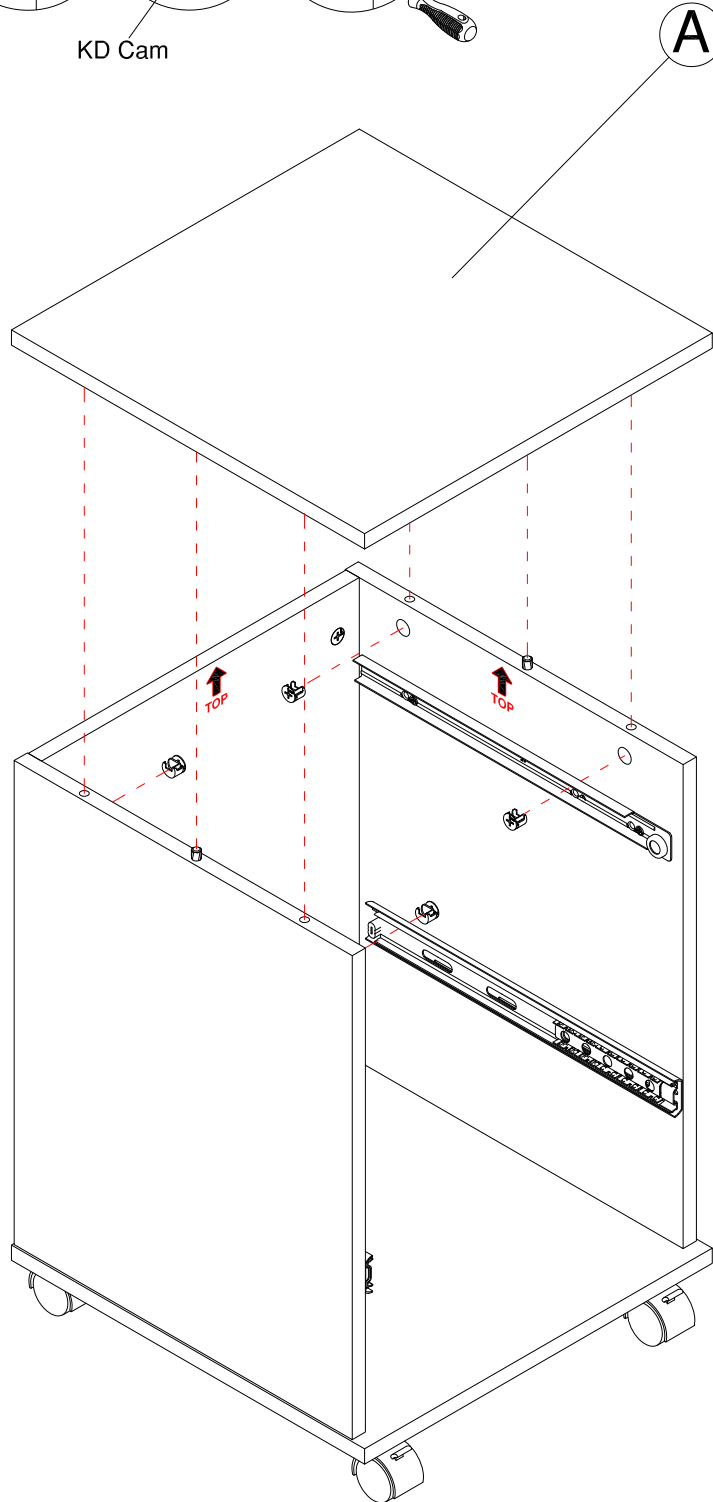

# STEP 19

# Insert Drawers

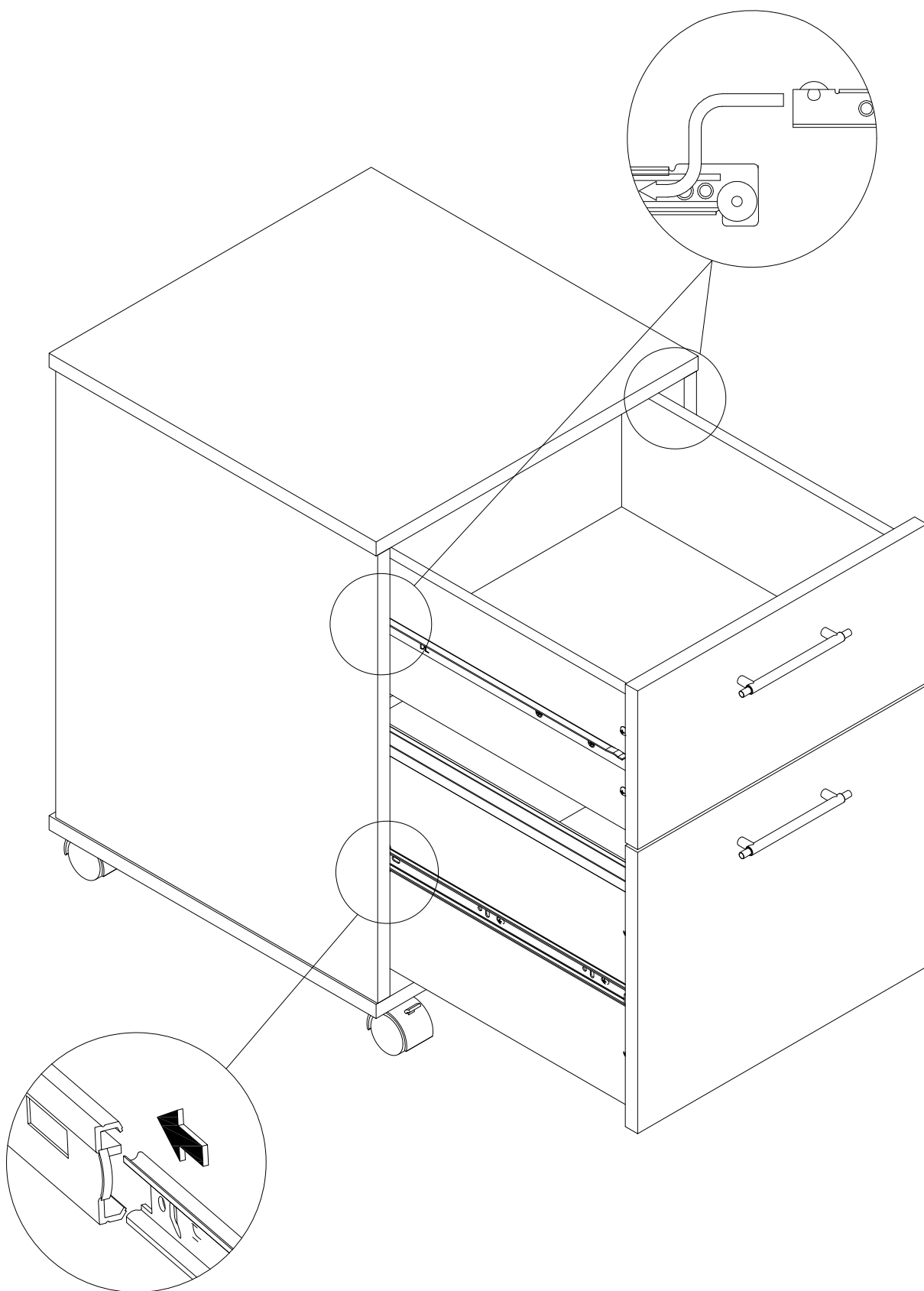

# STEP 20

# Drawer Adjustment

## DRAWER FRONT VIEW

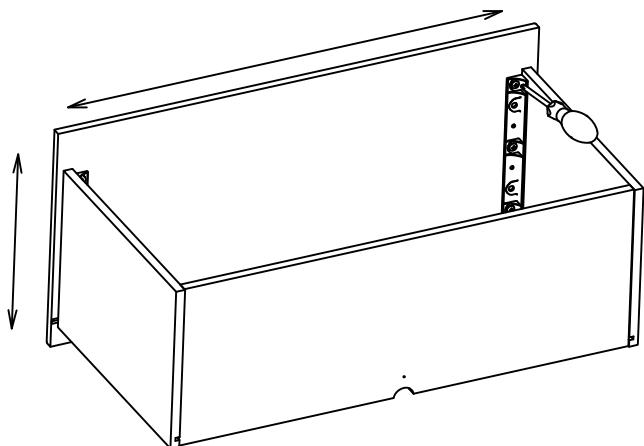
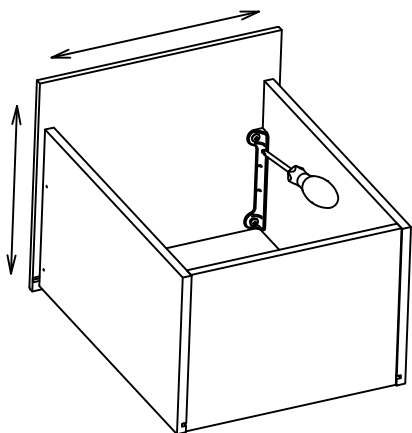
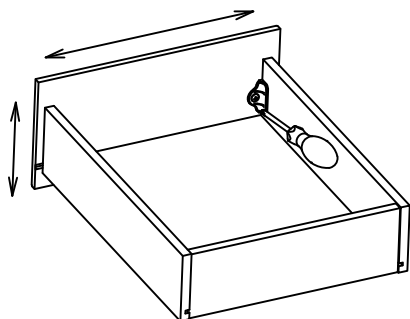
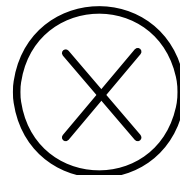
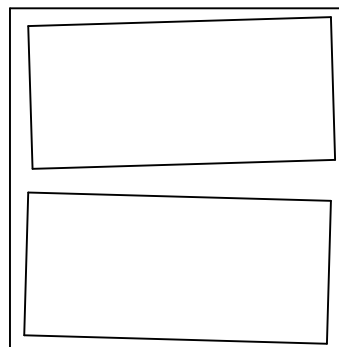
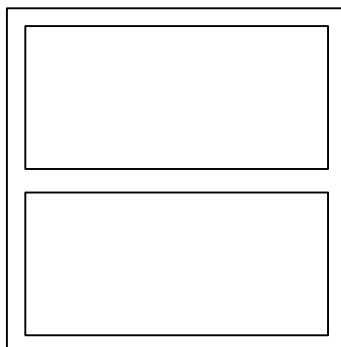

REQUIRED TOOL: PHILLIPS SCREWDRIVER

HERRAMIENTA REQUERIDA: DESTORNILLADOR PHILLIPS  
OUTIL REQUIS: TOURNEVIS CRUCIFORME

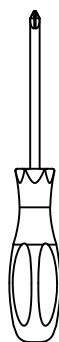

1. LOOSEN SCREWS.
2. ADJUST DRAWER FRONTS.
3. TIGHTEN SCREWS.

1. Afloje los tornillos
2. Ajustar frentes de cajón
3. Apriete los tornillos

1. Desserrer les vis
2. Ajuster les façades des tiroirs
3. Serrer les vis

# STEP 21

## Maximum Loading and Cleaning

Gently clean surfaces with a damp sponge eraser.

**MAXIMUM WEIGHT: 50 LBS (22.5 KG)**  
**PESO MÁXIMO: 50 LIBRAS (22.5 KILOGRAMO)**  
**POIDS MAXIMUM: 50 LIVRES (22.5 KILOGRAMME)**

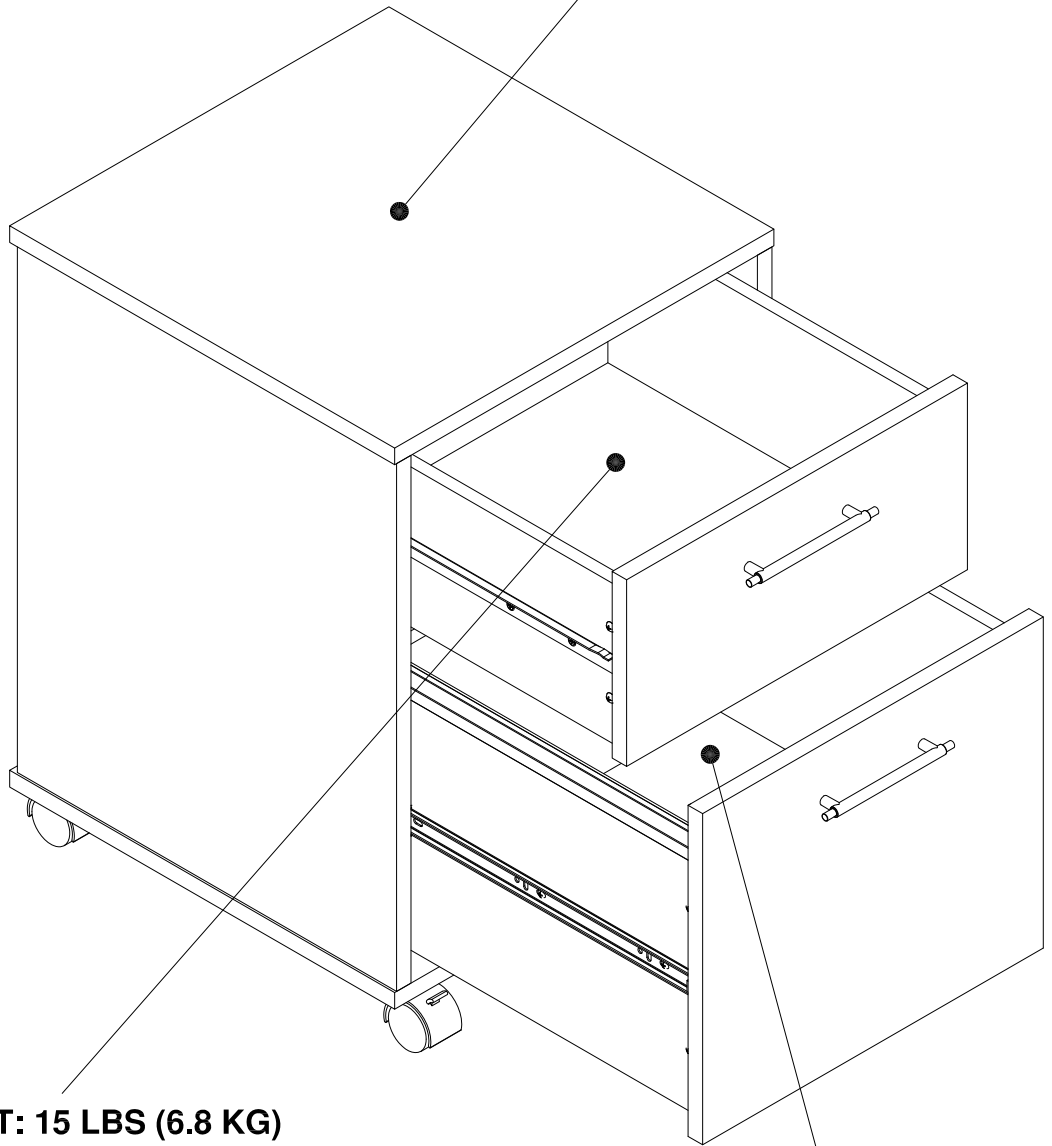

**MAXIMUM WEIGHT: 15 LBS (6.8 KG)**  
**PESO MÁXIMO: 15 LIBRAS (6.8 KILOGRAMO)**  
**POIDS MAXIMUM: 15 LIVRES (6.8 KILOGRAMME)**

**MAXIMUM WEIGHT: 30 LBS (13.61 KG)**  
**PESO MÁXIMO: 30 LIBRAS (13.61 KILOGRAMO)**  
**POIDS MAXIMUM: 30 LIVRES (13.61 KILOGRAMME)**

Congratulations! You are all done. If you have any questions or concerns, please call.

# PARTS LIST

A [1] W194908  
B [1] W194909  
C [1] W194910  
D [1] W194911  
E [1] W194912  
F [1] W194913  
G [1] W194914  
H [1] W194915

I [1] W194916  
J [1] W194917  
K [1] W194918  
L [2] W194919  
M [1] W194920  
N [1] W194921

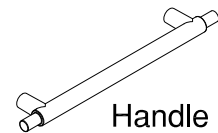

[ 2 ]

A [1] W194922  
B [1] W194923  
C [1] W194924  
D [1] W194925  
E [1] W194926  
F [1] W194927  
G [1] W194928  
H [1] W194929

I [1] W194930  
J [1] W194931  
K [1] W194932  
L [2] W194933  
M [1] W194934  
N [1] W194935

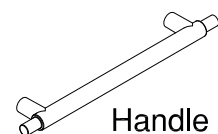

[ 2 ]

# PARTS LIST

A [1] W194936  
B [1] W194937  
C [1] W194938  
D [1] W194939  
E [1] W194940  
F [1] W194941  
G [1] W194942  
H [1] W194943

I [1] W194944  
J [1] W194945  
K [1] W194946  
L [2] W194947  
M [1] W194948  
N [1] W194949

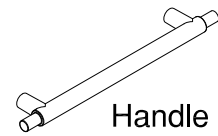

[ 2 ]

A [1] W194950  
B [1] W194951  
C [1] W194952  
D [1] W194953  
E [1] W194954  
F [1] W194955  
G [1] W194956  
H [1] W194957

I [1] W194958  
J [1] W194959  
K [1] W194960  
L [2] W194961  
M [1] W194962  
N [1] W194963

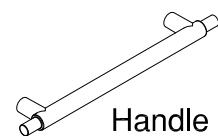

[ 2 ]

# PARTS LIST

A [1] W194964  
B [1] W194965  
C [1] W194966  
D [1] W194967  
E [1] W194968  
F [1] W194969  
G [1] W194970  
H [1] W194971

I [1] W194972  
J [1] W194973  
K [1] W194974  
L [2] W194975  
M [1] W194976  
N [1] W194977

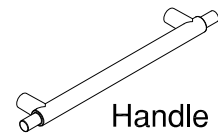

[ 2 ]

A [1] W182187  
B [1] W182188  
C [1] W182189  
D [1] W182190  
E [1] W182191  
F [1] W182192  
G [1] W182193  
H [1] W182194

I [1] W182195  
J [1] W182196  
K [1] W182197  
L [2] W182198  
M [1] W182199  
N [1] W182200

H180971

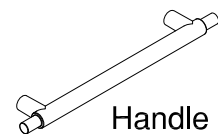

[ 2 ]

# PARTS LIST

A [1] W183036  
B [1] W183037  
C [1] W183038  
D [1] W183039  
E [1] W183040  
F [1] W183041  
G [1] W183042  
H [1] W183043

I [1] W183044  
J [1] W183045  
K [1] W183046  
L [2] W183047  
M [1] W183048  
N [1] W183049

H180971

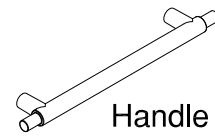

[ 2 ]

A [1] W190280  
B [1] W190281  
C [1] W190282  
D [1] W190283  
E [1] W190284  
F [1] W190285  
G [1] W190286  
H [1] W190287

I [1] W190288  
J [1] W190289  
K [1] W190290  
L [2] W190291  
M [1] W190292  
N [1] W190293

H180971

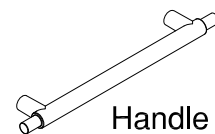

[ 2 ]

# WARRANTY INFORMATION/INFORMATIONS POUR LA GARANTIE/INFORMACIÓN DE GARANTÍA

## WRITTEN WARRANTY TO YOU

In order to provide you with timely assistance, please thoroughly inspect your furniture for missing or defective parts immediately after opening the carton. To receive replacement or missing parts under this warranty, call our Consumer Service Department. Please have the Model, Part, and Lot Numbers found in the instruction manual available for your reference. You will also need your sales receipt or other proof of purchase. Replacement part(s) will be shipped to you at no charge with assuming all ship-ping and handling charges.

This product is warranted to the original purchaser at the time of purchase and for a period of one year thereafter.

We warrant to you, the original purchaser, that our furniture and all its parts and components are free of defects in material or workmanship. "Defects," as used in this warranty, is defined as any imperfection which impairs the use of the furniture product.

Our warranty is expressly limited to the replacement of furniture parts and components. For one year after the date of purchase, we will replace any parts that are defective in material or workmanship.

This warranty applies under conditions of normal use. Our products are not intended for outdoor use. This warranty does not cover: 1) defects caused by improper assembly or disassembly; 2) defects occurring after purchase due to product modification, intentional damage, accident, misuse, abuse, negligence or exposure to the elements; and 3) labor or assembly costs.

IMPLIED WARRANTIES, INCLUDING THE WARRANTY OF MERCHANTABILITY, SHALL NOT EXTEND BEYOND THE DURATION OF THE WRITTEN WARRANTY STATED ABOVE, AND IN NO EVENT SHALL WE BE LIABLE FOR INCIDENTAL OR CONSEQUENTIAL DAMAGES RESULTING FROM USE OF THE PRODUCT.

Some states do not allow a limitation on how long an implied warranty lasts or the exclusion or limitation of incidental or consequential damages, so the above limitation and exclusion may not apply to you.

This warranty gives you specific legal rights. You may also have other rights that may vary from state to state.

## VOTRE GARANTIE

Afin de vous assister rapidement, veuillez inspecter votre mobilier en détail immédiatement après l'ouverture du carton en cas de pièces manquantes ou défectueuses. Pour recevoir une pièce de rechange ou manquante couverte par cette garantie, appelez notre département de service clientèle GRATUITEMENT au 1-800-950-4782. Veuillez tenir à disposition les numéros de modèle, de pièce et de lot qui se trouvent dans le manuel d'instruction pour votre référence. Vous aurez également besoin de votre reçu ou d'une autre preuve d'achat. La (les) pièce(s) de rechange vous sera (seront) envoyée(s) sans frais, se chargeant de tous les frais d'expédition.

Tout le produit est garanti à l'acheteur original à partir de la date d'achat pour une période d'un an.

Nous vous garantissons, à vous l'acheteur original, que notre mobilier et toutes ses pièces et composants sont sans défaut de matériau ou de fabrication. Le terme "défauts" utilisé dans cette garantie, est défini comme étant toutes les imperfections qui compromettent l'utilisation du meuble.

Notre garantie est expressément limitée au remplacement des pièces et des composants du mobilier. Pendant un an après la date d'achat, remplacera toute pièce défectueuse dans le matériau ou sa fabrication.

Cette garantie d'applique sous des conditions d'utilisation normale. Nos produits ne sont pas destinés à être utilisés en plein air. Cette garantie ne couvre pas: 1) les défauts causés par un mauvais assemblage ou démontage, 2) les défauts ayant lieu après l'achat et dus à la modification du produit, des dommages intentionnels, des accidents, une mauvaise utilisation, un mauvais traitement, la négligence ou l'exposition aux éléments, et 3) les frais de main d'œuvre ou d'assemblage.

LES GARANTIES TACITES, Y COMPRIS LA GARANTIE DE QUALITE MARCHANDE, NE S'ETENDRONT PAS AU-DELA DE LA DUREE ECRITE CITEE CI-DESSUS, ET NE SERA EN AUCUN CAS RESPONSABLE DES DOMMAGES ACCESSOIRES OU INDIRECTS RESULTANT DE L'UTILISATION DU PRODUIT. Certains états ne permettent pas d'appliquer une limite à la durée de la garantie tacite, ni une exclusion ou limitation des dommages accessoires ou indirects; dans ce cas les limitations ou exclusion ci-dessus peuvent ne pas s'appliquer à vous.

Cette garantie vous donne des droits légaux spécifiques. Il se peut que vous ayez également d'autres droits qui peuvent varier d'un état à l'autre.

## GARANTIA ESCRITA

Para brindarle asistencia oportuna, por favor, verifique detalladamente que a su mueble no le falte o tenga piezas defectuosas inmediatamente después de abrir la caja. Pararecibir un reemplazo o la parte faltante bajo esta garantía, llame a nuestro Departamento de Servicio al Consumidor GRATIS al 1-800-950-4782. Sírvase traer los números de modelo, parte y lote que se encuentran en el manual de instrucciones disponible para su referencia. Además, necesitará el recibo de su compra u otra prueba de compra. La(s) pieza(s) de reemplazo le será(n) enviada(s) sin recargo por asumiendo los gastos de envío y manipuleo.

Todo mueble es garantizado al comprador original al momento de la compra y por un periodo de uno año en adelante.

Le garantizamos a usted, el comprador original, que nuestros muebles sus partes y componentes están libres de defectos en materiales o trabajo. "Defectos", según se usa en esta garantía, se define como una imperfección que perjudica el uso del producto mobiliario.

Nuestra garantía se limita expresamente al reemplazo de partes y componentes mobiliarios. Durante uno año después de la fecha de compra, reemplazará cualquier parte defectuosa en material o trabajo.

Esta garantía se aplica bajo condiciones de uso normal. Nuestros productos de no son para uso en exteriores. Esta garantía no cubre: 1) defectos causados por un ensamblaje

o desensamblaje inadecuado; 2) defectos que ocurran después de la compra debido a modificación del producto, daño intencional, accidente, mal uso, abuso, negligencia o exposición a los elementos; y 3) costos de trabajo o ensamblaje.

LAS GARANTÍAS IMPLICADAS, INCLUYENDO LA GARANTÍA DE COMERCIABILIDAD, NO SE EXTENDERÁN MÁS ALLÁ DE LA DURACIÓN DE LA GARANTÍA ESCRITA MENCIONADA, Y EN NINGÚN CASO SERÁ RESPONSABLE POR DAÑOS INCIDENTALES O CONSIGUIENTES COMO RESULTADO DEL USO DEL PRODUCTO. Algunos estados no permiten una limitación sobre el tiempo de duración de la garantía implicada o la exclusión o limitación de daños incidentales o consiguientes, de manera que la limitación y exclusión mencionadas pueden no aplicarse para usted.

Esta garantía le otorga derechos legales específicos. Puede también tener otros derechos que pueden variar según los estados.