

# Assembly Instructions

**Caution: You must read this before you proceed**

## Daybed

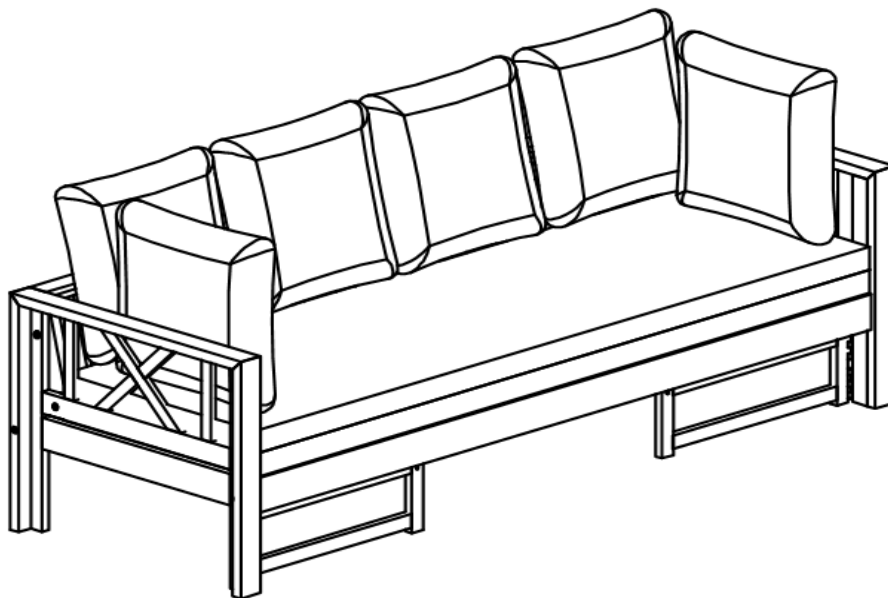

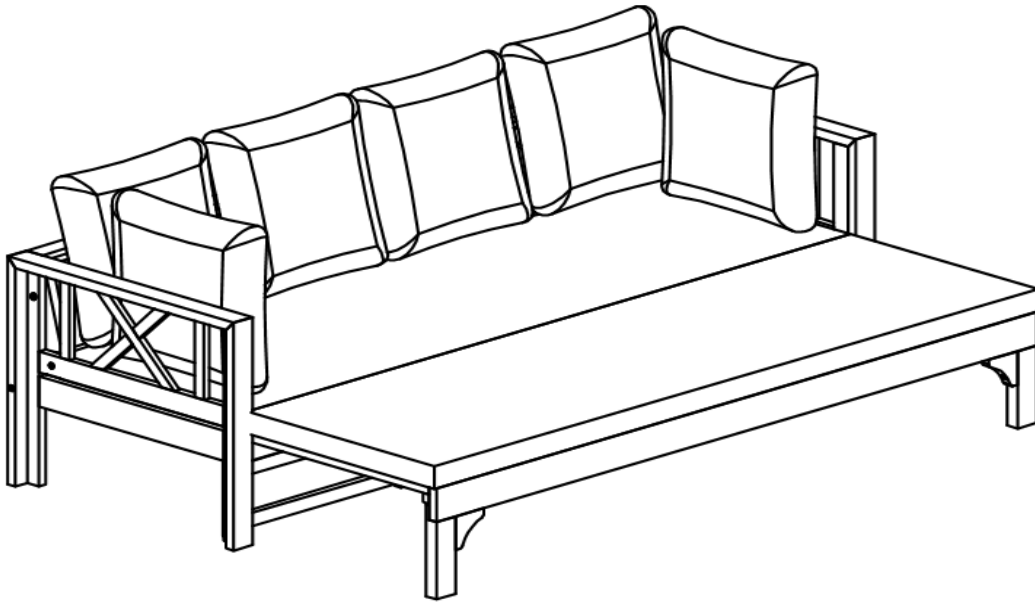

**CAUTION** : This Daybed is NOT a TOY.





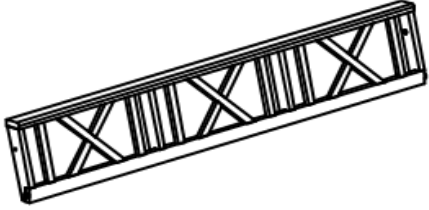
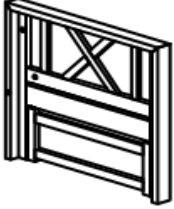
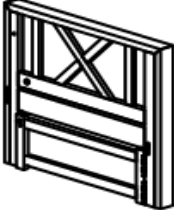
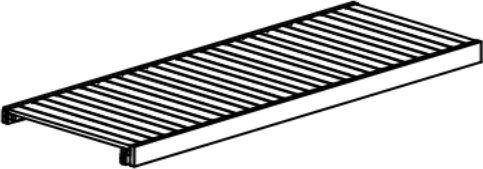
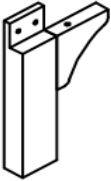
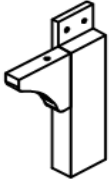
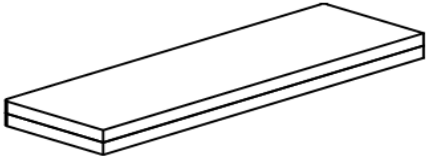

Keep your child/children at bay during the assembly process.

Whenever lifting or moving the Daybed, two adults may be needed to execute these actions.

# Part List

Label	Picture	Description	QTY
A		Backrest Panel	1
B		Left Leg Panel with Support Leg	1
C		Right Leg Panel with Support Leg	1
D		Extendable Seat Panel	1
E		Left Front Leg	1
F		Right Front Leg	1
G		Foldable Seat Cushion	1
H		Back Pillow	6





# Hardware

Label	Picture	Description	QTY
①		Allen Key	2
②		Bolt (M6x25mm)	5
③		Bolt (M6x35mm)	3
④		Sleeve Nut (M6x15mm)	3
⑤		Screw (M7x90mm)	3
⑥		Screw (M7x70mm)	5
⑦		Screw (M6x60mm)	3

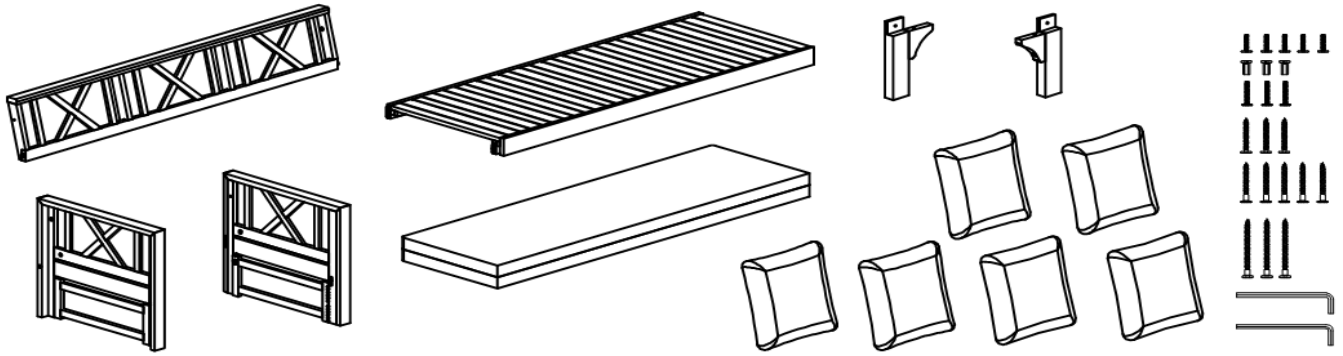
# Assembly Preparation

Before Beginning Assembly:



-  • Read instructions, cover to cover-
-  • Have 2 adults on hand for assembly-
-  • Do not assemble on flooring or carpet-
-  • Assemble on a clean non-marring surface (packing foam)-
-  • Save all packaging until finished-

# Assembly Steps

## Overview

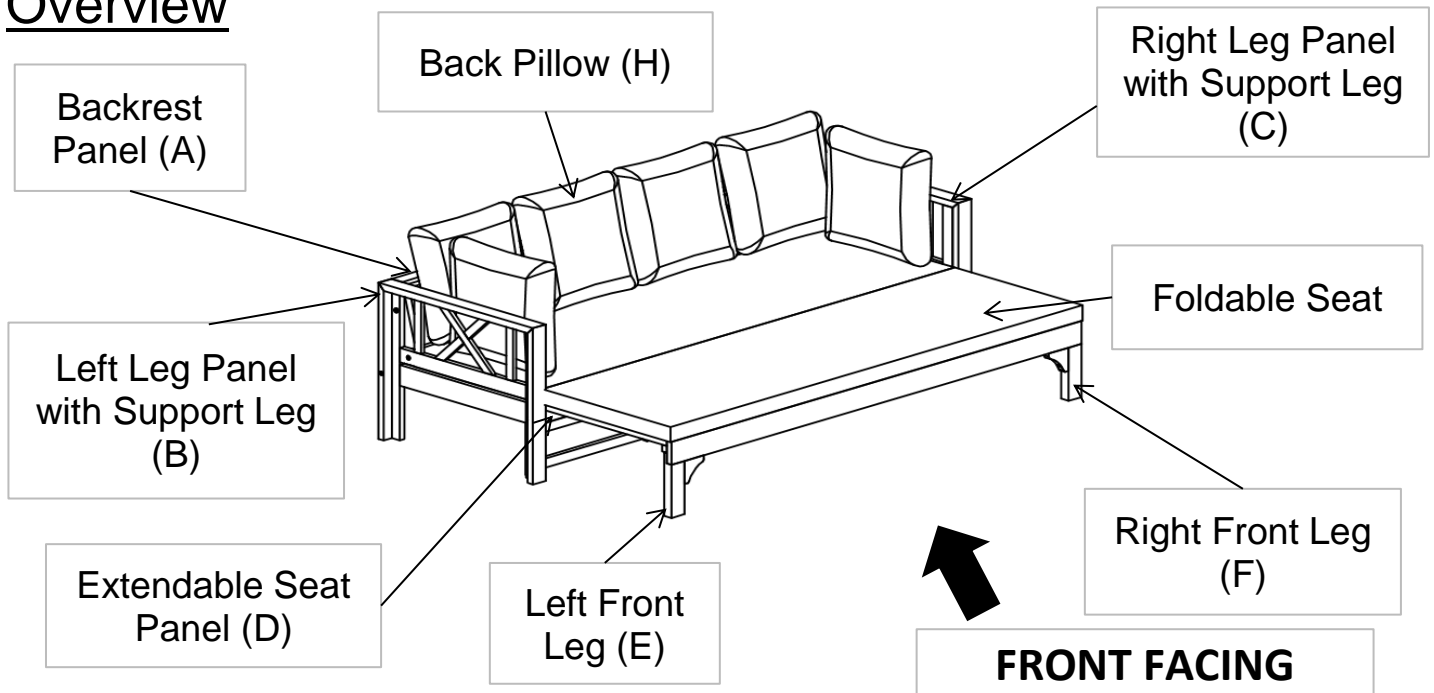

This Daybed has multiple parts and may require up to 30 minutes to assemble. To give you an overview of the Daybed, the above picture is to help you put the various parts into perspective. Please read through the instructions below to familiarise yourself with the parts and steps before assembly.

## Step 1

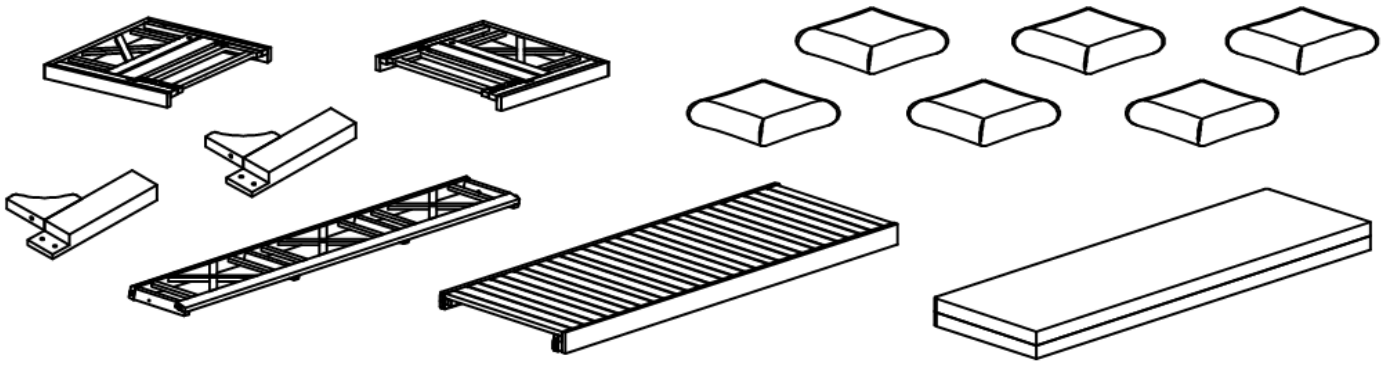

Unpack and place all parts on a clean, non-marring surface.

## Step 2

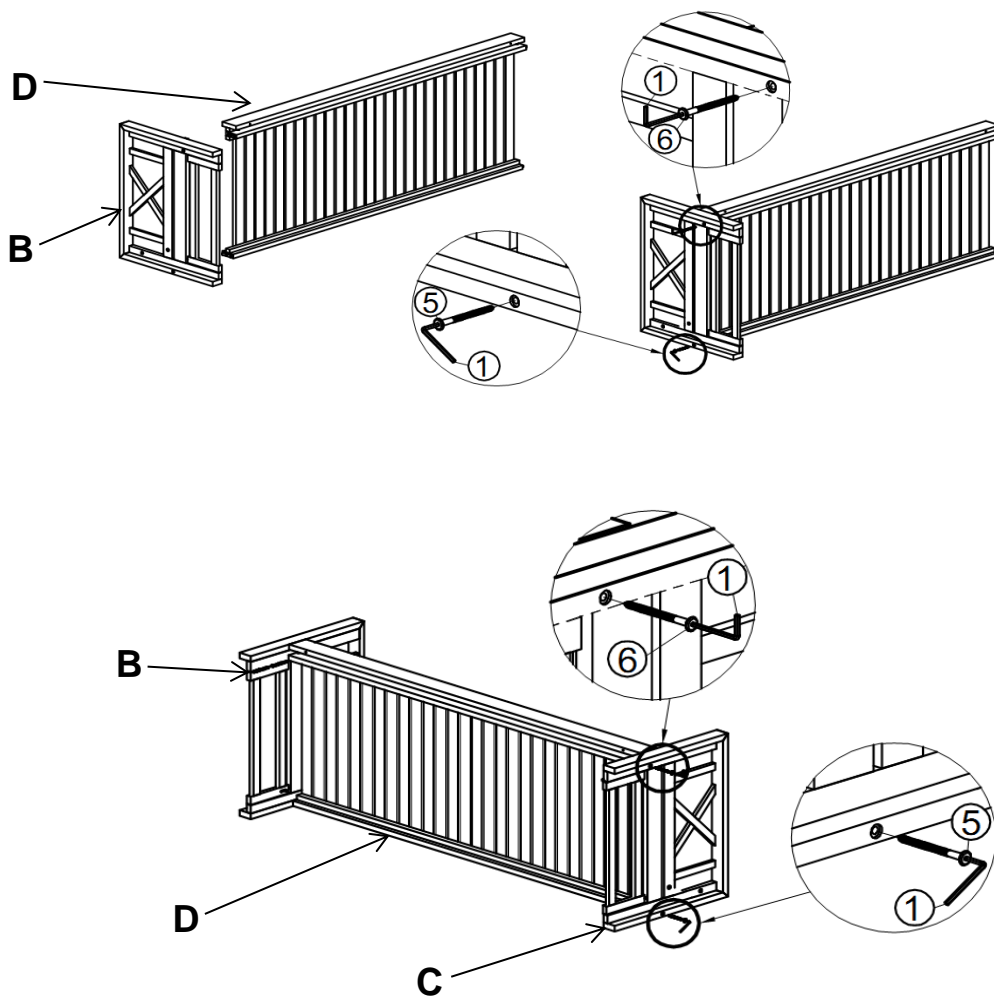

With assistance from your adult partners, attach Left Leg Panel with Support Leg(B) to Extendable Seat Panel(D) using Screw(⑤) and Screw(⑥) with Allen Key(①) as shown in above picture.

Repeat the same process to secure Right Leg Panel with Support Leg(C) to Extendable Seat Panel(D).

**Do not fully tighten the Screws.**

## Step 3

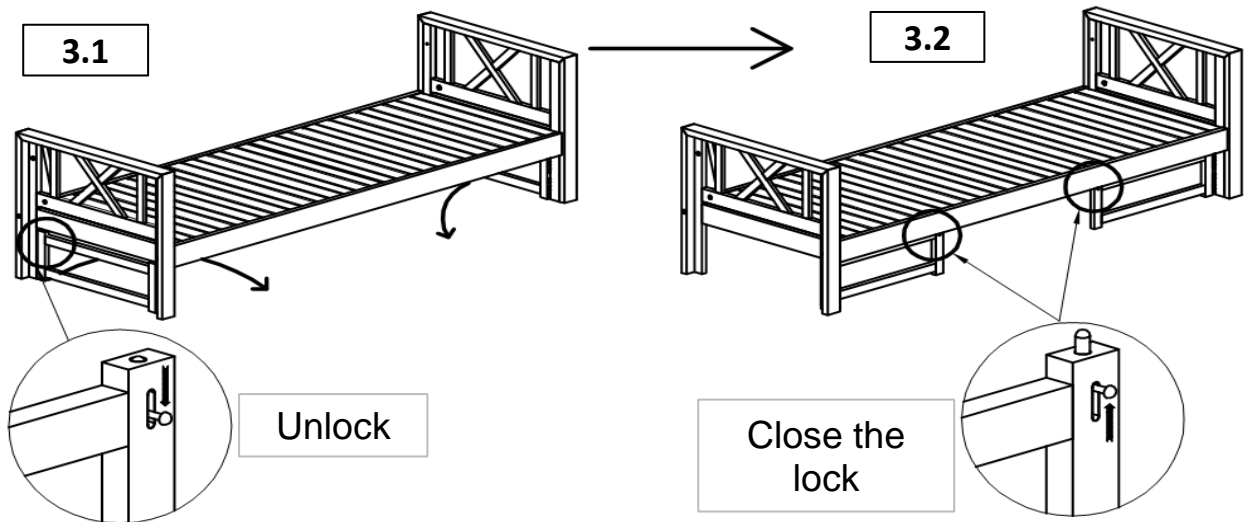

With assistance from your adult partners, turn the Daybed right side up.

**3.1)** Pull down the button on Left Leg Panel with Support Leg(B) to unlock Support Leg.

**3.2)** Turn Support Leg into position as shown in above picture, then pull up the button to lock the Support Leg.

## Step 4

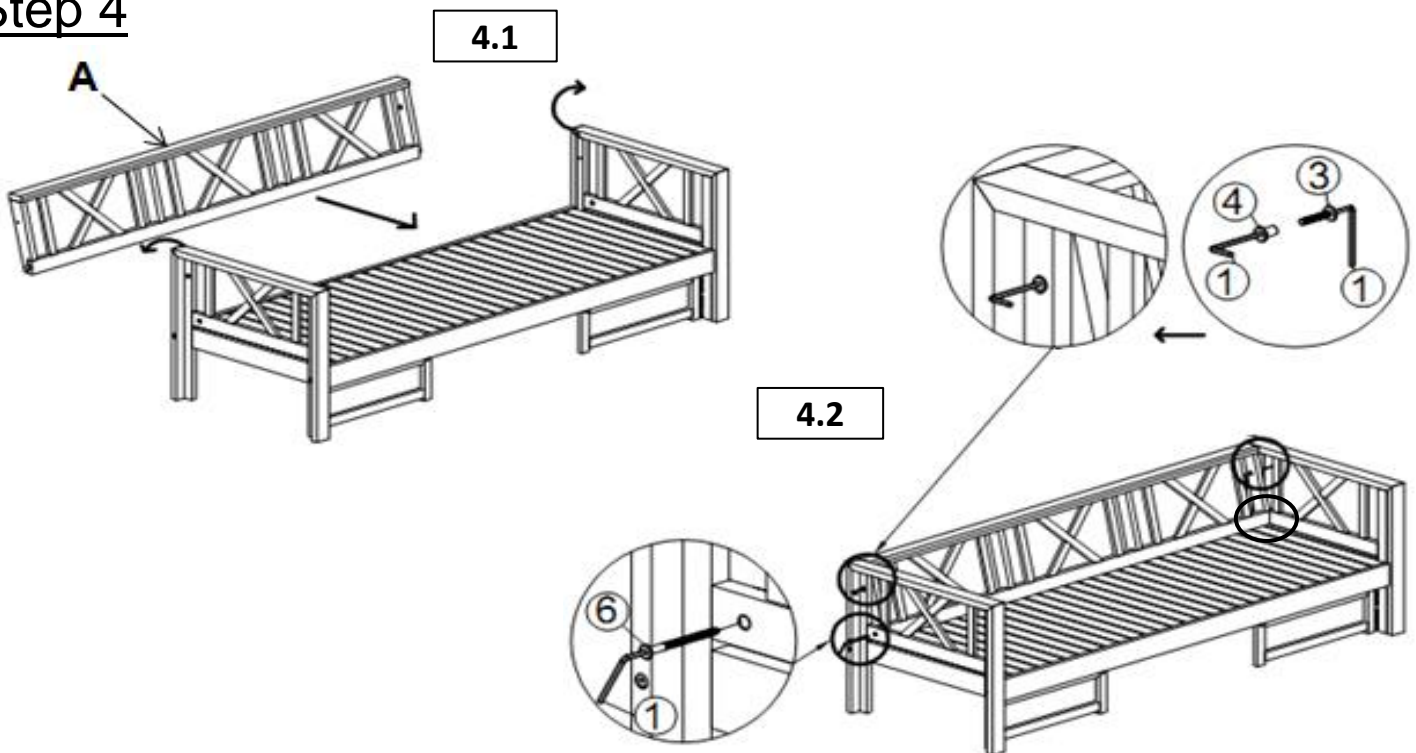

**4.1)** With assistance from your adult partners, slightly pull apart the Leg Panels to position the Backrest Panel(A) between the Leg Panels.

**4.2)** Secure Backrest Panel(A) to Left Leg Panel with Support Leg(B) using Bolt(③) and Sleeve Nut(④) with Allen Keys(①) as shown in above picture.

Then using Screw(⑥) and Allen Key(①) continue to secure Backrest Panel(A) to Left Leg Panel with Support Leg(B).

Repeat the same process to secure Backrest Panel(A) to Right Leg Panel with Support Leg(C).

**Do not fully tighten the Screws and Bolts.**

## Step 5

5.1

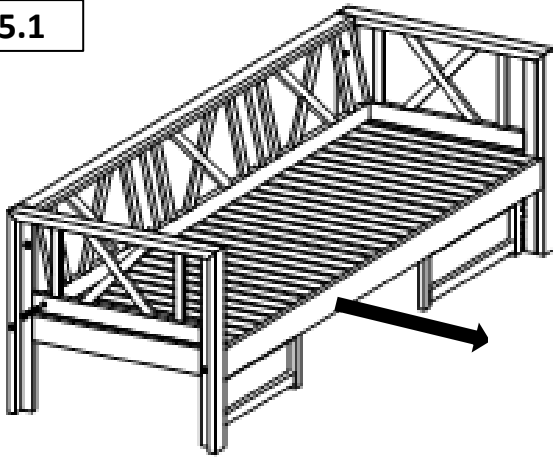

5.2

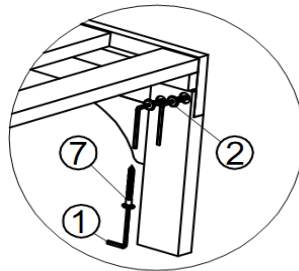
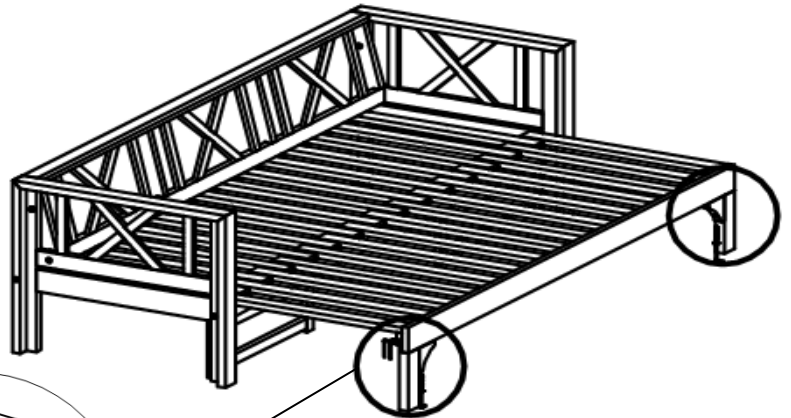

**5.1)** With assistance from your adult partners, pull out the Extendable Seat Panel(D) in the direction of the arrow as shown in above picture.

**5.2)** Vertically, using Screw(⑦) with Allen Key(①) and horizontally, using 2 Bolts(②) with Allen Key(①) attach Left Front Leg(E) to Extendable Seat Panel(D).

Repeat the same process to attach Right Front Leg(F) to Extendable Seat Panel(D).

**Fully tighten all the Screws and Bolts at all joints in a sequential manner.**

## Step 6

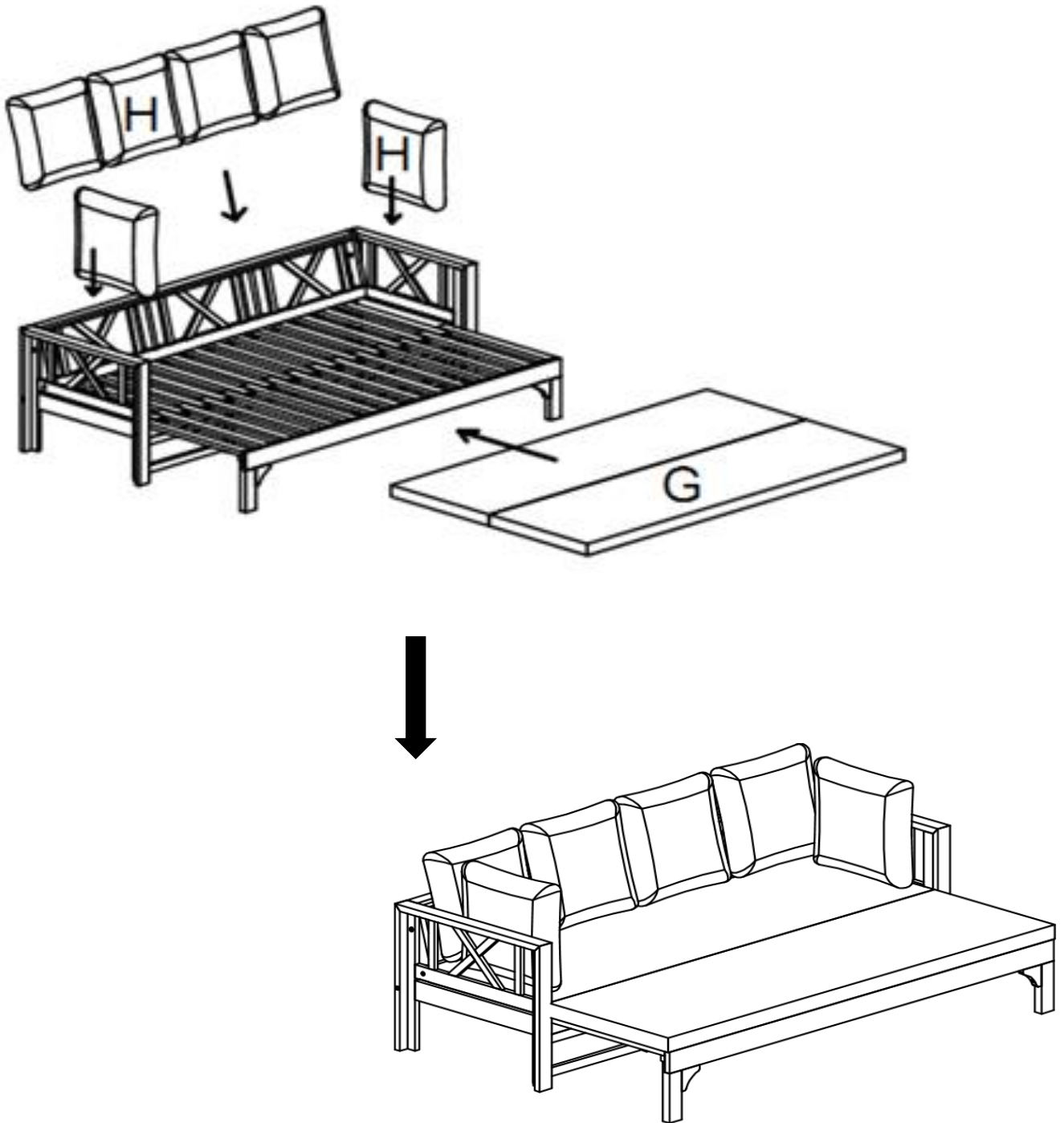

Place Extendable Seat Cushion(G) and Back Pillows(H) onto the Daybed as shown in above picture.

Your Daybed is now ready to used.

**This Daybed can only be used on a flat, level surface.**

## To Retract the Daybed:

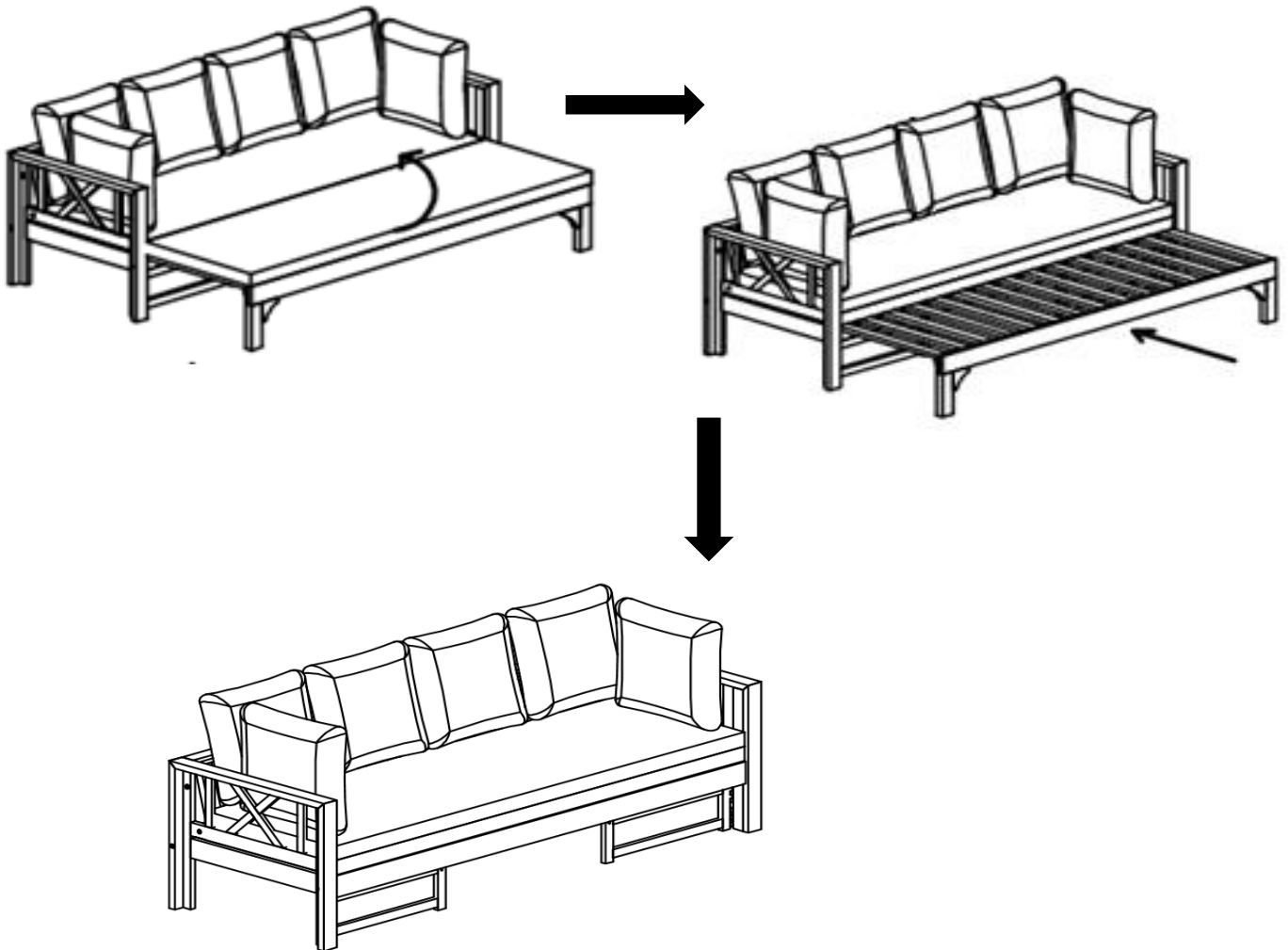









Fold Foldable Seat Cushion(G) in the direction of the arrow and then, push the Extendable Seat Panel(D) to shorten the Daybed as shown in above picture.

Your Daybed is now ready to used.

**This Daybed can only be used on a flat, level surface.**

## Care & Maintenance

- ⊘  ● Do not put hot items directly on furniture surface.
  - ⊘  ● Do not clean furniture with harsh cleansers or polish.
  - ✓  ● To obtain the longest lifespan of your outdoor products, minimizing exposure to direct sunlight is recommended.
  - ⊘  ● Children should not climb or jump on the furniture.
  - ⊘  ● Do not write on furniture without a padded barrier to protect the surface.
  - ✓  ● To obtain the longest lifespan of your outdoor products, avoid extended and lengthy exposure to rain, snow, and direct sunshine. Whenever possible cover the product and /or place under patio or awnings.
  - ⊘  ● Not for commercial use. For residential use only.
  - ⊘  ● Stains may be removed with mild soap solution and damp cloth.
  - ✓  ● Dust and pick-up spills using a clean, non-colored, lint-free cloth .
-