

询价	打样	试制	受控
<input type="checkbox"/>	<input type="checkbox"/>	<input type="checkbox"/>	<input checked="" type="checkbox"/>

标记	处数	变更内容	设变人	日期

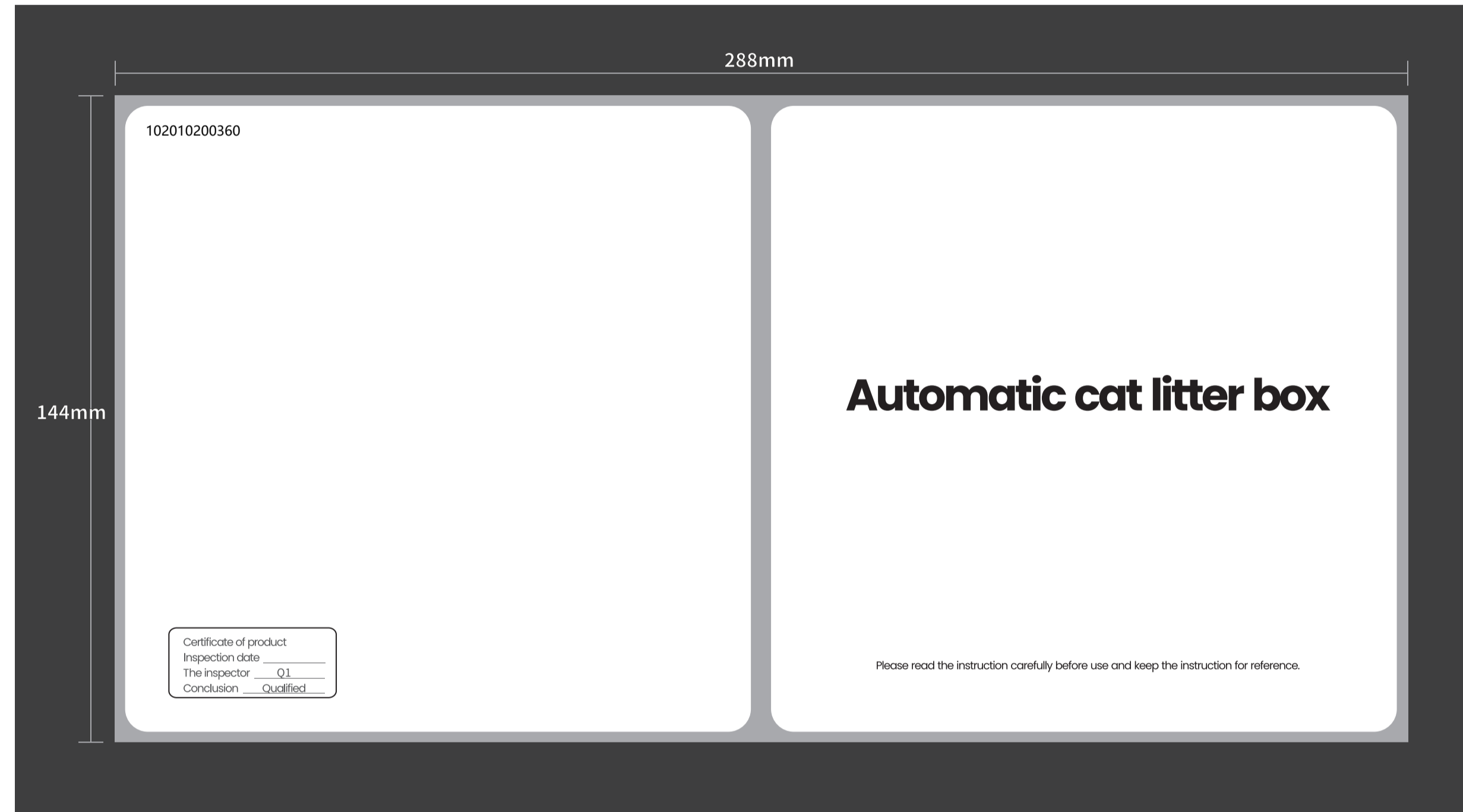

技术要求:

- 规格: 单页144\*144mm。
- 材质: 100g双胶纸\20P
- 颜色: 按图示印刷
- 字体要求: 字体印刷清晰, 无漏印, 错印现象。
- 成型要求: 骑马订成型。

外观区域划分图:		浙江朝泓新材料科技股份有限公司					
		成品编码	/	成品名称	ICB018猫砂盆		
		零件编码	102010200360	零件名称	说明书		
		图号	/	模具编号	/		
基本尺寸	未注公差	材料	/	颜色	/		
0~50	±0.1	设计	张阳	日期	2025/8/30		
> 50~150	±0.3	审核	杨城	日期	2025/8/30		
> 150~300	±0.5	批准	陳小均	日期	2025/8/30		
> 300~500	±1.0	单重	/	版本号	V1.0	单位	mm
> 500~1000	±1.5	投影方向	⊕	图幅	A4	比例	1:1
未注角度	±1°	第1页, 共10页					
/		此图纸为朝泓公司©版权所有, 未经书面许可不得复制!					

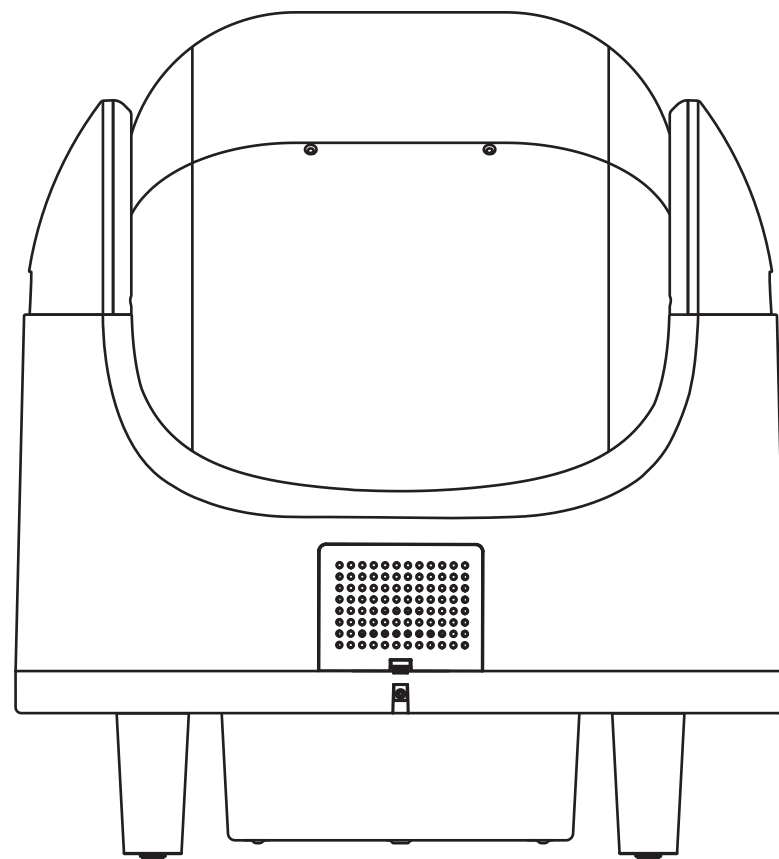
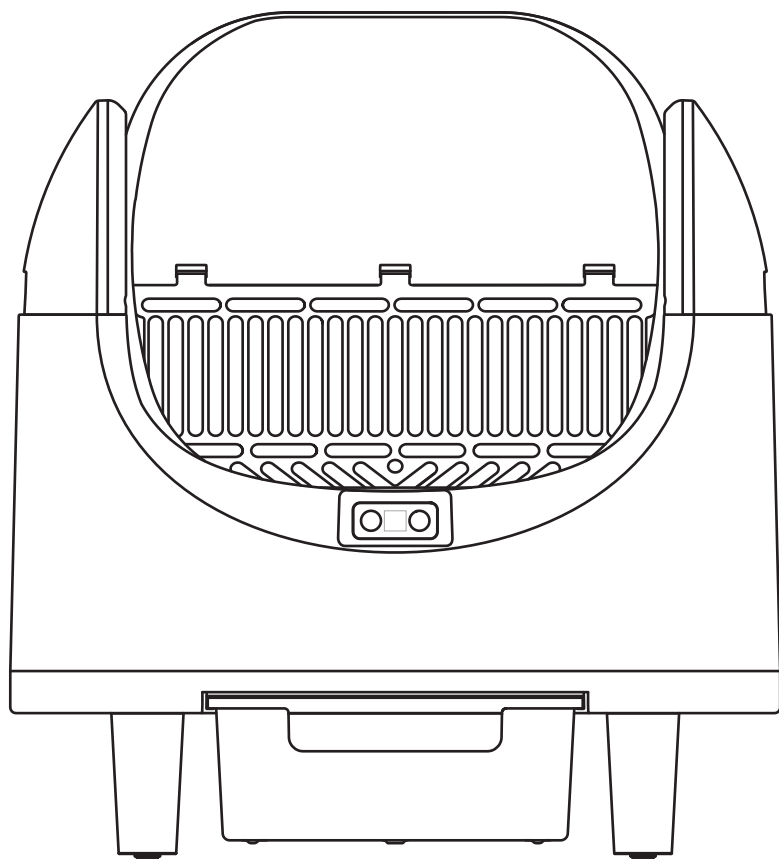

## Directory

### Product Introduction

Body structure description 01  
Operation Panel 02

### Installation instructions

Complete Installation 03  
Aromatherapy box replacement 07

### Cleaning and maintenance

Daily Maintenance 05  
Product Clean 06

### Safety warning

No forced attention 08

### Service guide

Product parameter 10  
Fault self-test 11  
Warranty Notice 13

## WiFi network configuration instructions

This product can through the "Tuya Smart" APP

1. Search for "Tuya Smart" APP in the mobile app store to download and install.
2. Keep the phone's WiFi and Bluetooth turned on - press and hold the cat litter box WiFi button for 3 seconds and a beep will sound - open the APP and click Add Device in the upper right corner - wait for automatic search and discovery of the device - then add the device - enter the WiFi password and wait for the connection to succeed.
3. If the route account or password of a device user is changed, the device cannot connect to the device. In this case, perform the preceding steps and hold down the WiFi button for 3 seconds to reconfigure the network.
4. Because the APP to upgrade or update, the actual operation may be slightly different with the description, please refer to our current APP guidance, or consult the official customer service.

#### Attention!

The device only supports 2.4G WiFi band. Please ensure that the router is in 2.4G band when connecting.

## Product introduction

### Main structure description

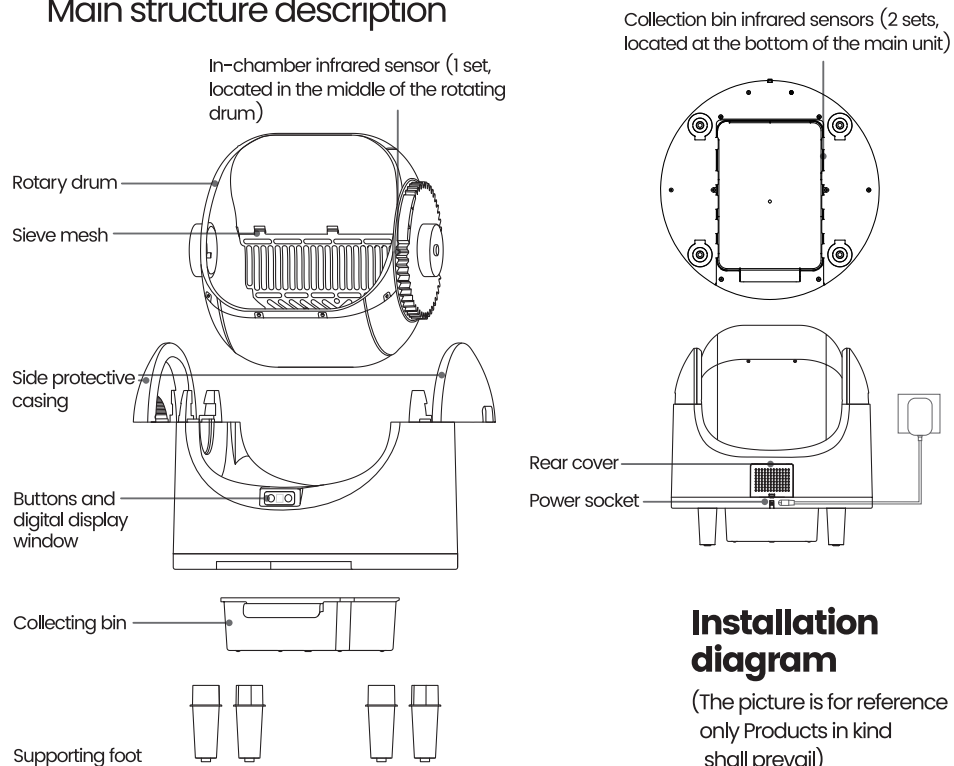

-01-

### List of parts



Instruction x1



Power Adapter x1



Solid aromatherapy box x1



Garbage bag x1

### Operating panel

#### Cleaning button

- **Usage:** Press once to start cleaning, press and hold for 5s to activate cat litter emptying
- **Steady green light:** In operation
- **Slow-flashing yellow light:** Waste collection bin full

#### Digital Display Window

- **Number 0:** Delayed waste removal
- **Number 2:** Anti-pinch activated
- **Number 3:** Waste collection bin full

#### WiFi button

- **Usage:** Press and hold for 3s to configure or deconfigure the network
- **Steady yellow light:** Network disconnected or waiting for connection
- **Slow-flashing yellow light:** In the process of connecting to the network
- **Steady green light:** Network connection successful

--

02

## Installation instructions

### Complete installation

#### Installation of support feet



①. Take out the drum and other accessories, put the machine (as shown) upside down on the table, take out the four support legs and insert them into the corresponding positions in turn, pat them to ensure the installation.

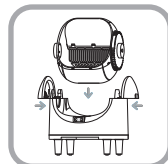

②. Place the machine on a hard and flat floor, install the drum first, and then press both sides of the handle inward by hand to install.

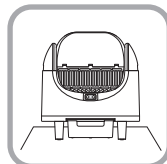

③. Place the machine on a hard and flat floor, install the drum, Side protective casing and collection bin, and ensure that the machine does not shake as the standard. (Prohibited from being placed on carpets.)

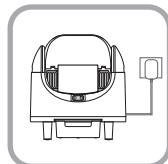

④. Connect the power supply. The machine will start resetting after 10s. Check whether the button display is correct.

#### Aromatherapy box installation



①. Find the cover plate on the side and press the two clasps on the cover plate, and then remove the cover plate.

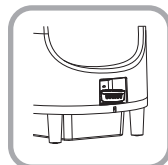

②. Put the aromatherapy box with the protective film removed in the product card slot and push it to the bottom.

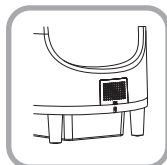

③. Reset the cover plate of the product.

#### Attention!

Before installation, please carefully read the instruction manual and check the accompanying accessories.

#### Add cat litter

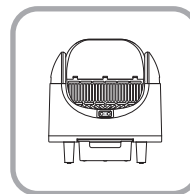

①. Unplug the power and the machine stops running.

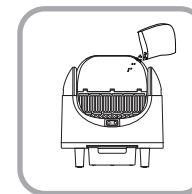

②. Pour an appropriate amount of cat litter. (Recommendation: Use "fine-grained" cat litter)

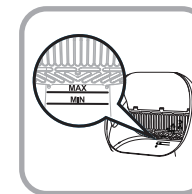

③. The amount of cat litter poured should be between the "MIN" and "MAX" markings.

#### Install bin garbage bags

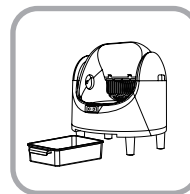

①. Pull out the collection bin

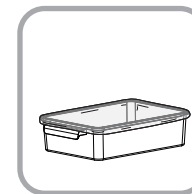

②. The garbage bag is first set to the rear two corners, and then pulled back and stuck on the front two corners, and then smooth, reset the collection bin.

①. Before adding cat litter each time, please unplug the power supply, and plug it back in after adding the litter; alternatively, press the cleaning button briefly once to reset and level the litter after each addition.

②. Recommendation: Use "fine-grained" cat litter!  
③. It is recommended that the cat litter has a length of no more than 10mm and a diameter of no more than 1.5mm.

## Instructions for use

### Operating instruction | Power on

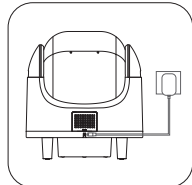

Insert the power adapter connector into the port on the rear of the product, ensuring it is fully inserted.

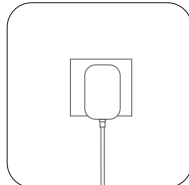

Insert the plug blade end of the power adapter into the electrical outlet.

### Daily maintenance

**Note!** Maintenance work is not within the scope of maintenance.

- A dedicated aromatherapy box should be used to ensure the deodorizing effect.
- Matching special garbage bags should be used to ensure the cleaning effect of products.

## Replacement of toilet bowl and aromatherapy box

### Clean the collection bin

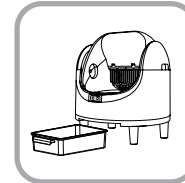

①. Pull out the collection bin.

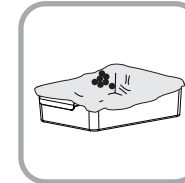

②. Take out the garbage bag and tighten the handle to seal it.

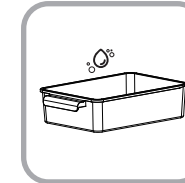

③. The collection bin can be washed dry with clean water, and then reset after loading a new garbage bag.

### Rotary cleaning

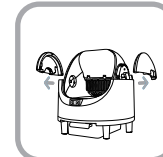

①. Grasp the handle holes on both vertical semicircular plastic casings and pull them out horizontally.

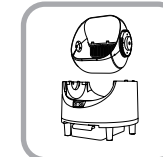

②. Lift out the rotating drum.

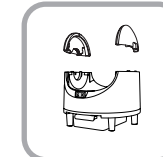

③. Wipe the interior of the product with a damp towel.

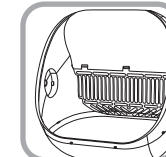

④. Locate the screen mesh inside the rotating drum, grasp its end, pull upward to disengage from the clips, and remove.

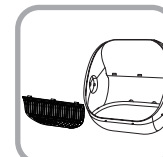

⑤. Take out the screen.

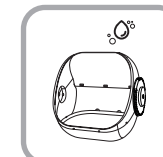

⑥. The rotary cylinder is cleaned directly with water.

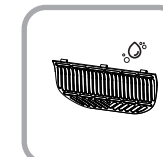

⑦. Screen cleaning alone, dry after reset.

## Aromatherapy box replacement



①. Power off, find the back cover on the back and take it off

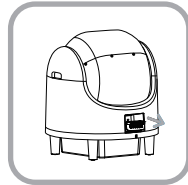

②. Pinch the bottom of the aromatherapy box and take it off



③. Put the good aromatherapy box at the product card slot and push it to the bottom.



④. Reset the rear cover of the product

## Safety warning

### Note!

To ensure safety and avoid injury and property damage to yourself and others, please observe the following safety precautions. Misuse may result in accidents.

⊘ Indicates prohibited content



Keep out the sun



No flammable articles



No wet area



Do not touch with wet hands



Avoid washing or submerging the unit in water



Do not place on uneven ground



Do not place on carpets and soft surfaces

- The machine should be placed in a cool and dry place in the room. Avoid the place exposed to strong sunlight, otherwise it will easily cause aging of product parts.
- Do not allow young children to handle, touch, approach or climb. Children and people with intellectual disabilities should use it with a guardian.
- Do not use gasoline and other organic solution to wipe the fuselage, the product is strictly prohibited to wash, water. Do not put the product in contact with or near inflammable and explosive materials.
- In order to save electricity, disconnect the corresponding power switch when not in use for a long time, and clean the remaining sand in the machine. Install and fix the machine before it can be used.
- Do not connect the booster transformer to the power plug.
- The machine is not allowed to be used in the place where there is water spraying, and electrical appliances are not allowed to be used in the cabinet. The device should be at least 10cm away from the wall, and no other items should be placed on the bottom and surrounding areas.
- The product must be placed on a clean and flat hard surface, and should not be placed on soft carpets or floors.

! Indicates mandatory content



Need professional-  
als

- It is strictly prohibited to extend the power cord arbitrarily to avoid fire
- If the power cord is damaged, it must be replaced by the manufacturer, maintenance department or professionals to avoid danger

### ⚠ May cause minor injury or damage to property

- When cutting off the power supply, do not pull the power cord directly to prevent it from being broken. Keep flammable and volatile substances away from the machine. In the transportation and loading and unloading process, should be handled lightly, prevent a collision scratch products and accessories.
- The machine shall not be installed outdoors. Should be placed in a ventilated, dry, temperature of 4-40 C, relative humidity does not exceed 60%, In an environment without corrosive gases. After the machine is out of service, empty the cat litter in the bucket and the cat feces in the collection bin.
- Keep the power plug clean. Do not insert or remove the power plug with wet hands.
- There will be slight vibration and noise when the drum is rotating, which is a normal phenomenon.
- Wet or dusty areas may cause circuit damage. High magnetic appliances are nearby, which may cause fire, product damage or circuit failure.
- When moving the product, handle it gently and avoid dragging it.
- Do not place other items on the top of the product, which may affect the normal work of the product.
- The product can only be used on the special accessories provided by our company.

#### Precautions and Troubleshooting Causes for networking failure:

- To ensure smooth networking of the product, please ensure that the whole machine is installed in a place with strong wireless network.
- This equipment contains a radio transmitting module with model approval code CMIID:2020DP6462 and device model :WBR3.

## Service guide

### Product parameter

Due to product improvement, the following parameters are subject to change, mainly the product nameplate

Model number	
Rated voltage	12V==
Rated power	9W
Product size	535*535*600mm
Product package size	560*560*440mm
Litter Container Capacity	8L

## Fault self-test

**Note!**

The following is the common judgment and inspection, if simple treatment cannot be eliminated, please send to the maintenance network or Call the customer service hotline for consultation. Please do not disassemble and repair by yourself to avoid danger or Cause damage to the product.

Problem	Cause	Treatment method
<b>Networking failure</b>	The product is not energized	Electrify the product
	No network exists in the place where the product is located	Check whether there is a network
	The phone did not turn on Bluetooth	Turn on Bluetooth
	WiFi is not a 2.4G signal	WiFi is adjusted to 2.4G signal Press and hold the Wi-Fi button to refresh the network
<b>The product is energized, and the drum does not rotate</b>	Product accessories are not installed in place; The required adapter is not used.	Check and reinstall product accessories; Check that the adapter power matches that of the machine nameplate.
<b>The digital display shows the number 1, and the drum does not rotate</b>	Delayed waste removal. (protection mechanism)	Please confirm that the cat has left the litter box, and then wait for the product to clean automatically.
<b>The digital display shows the number 2, and the drum does not rotate</b>	The infrared sensor inside the drum is blocked.(anti-pinch protection activated)	Check if there is any foreign matter blocking the infrared sensors on both sides of the rotating drum. Clean it off to restore normal operation.
<b>The yellow lights of the Emptying and Cleaning buttons flash slowly, the digital display shows the number 3, and the drum does not rotate</b>	The infrared sensor of the waste collection bin is blocked.	Check if the waste collection bin is full, or if there is any foreign matter blocking the infrared sensor beads on both sides. Clean them up to restore normal operation.

## Skills:

1. The machine is placed on a flat hard ground, and there are four black parts on the bottom that should be in contact with the same plane.
2. Make sure the cat weighs more than 1kg, otherwise it may cause the cat to be injured.

QR Code iOS:



QR Code Android:



## Warranty instructions

### Maintenance service guarantee

In case of product failure, please contact our local distribution service network or customer service center. The litter box is guaranteed for one year. Consumables are not covered by warranty, please purchase them by yourself after use.

The start date of the warranty period is subject to the invoice of the product. The following conditions are not covered by the warranty:

1. Damage caused by improper use, storage and maintenance of consumers.
2. Damage caused by disassembly and repair without the company's designated maintenance department.
3. The model of the invoice is inconsistent with the model of the maintenance product or altered.
4. No valid invoice.
5. Force majeure causes damage.
6. We are not responsible for the quality accidents caused by the non-standard gifts or accessories of our company.
7. This product is used for non-household purposes, the whole machine warranty will be implemented for half a year.
8. Failure caused by human or improper use is not covered by warranty.
9. Please use the spare parts provided by our company. Old parts cannot be reused.
10. Failure or damage caused by forced use of the product beyond normal conditions is not covered by the warranty. For products not covered by warranty, our customer service center is still willing to serve you.

Product implementation standards:  
GB 4706.1-2005

### **Note!**

All contents in this manual have been checked. If there is any typographical error or misunderstanding in the content, please refer to the company. If there is any technical improvement, it will be included in the new manual without prior notice. If the appearance and color of the product are changed, the physical object shall prevail.