

# ASSEMBLY INSTRUCTIONS

---

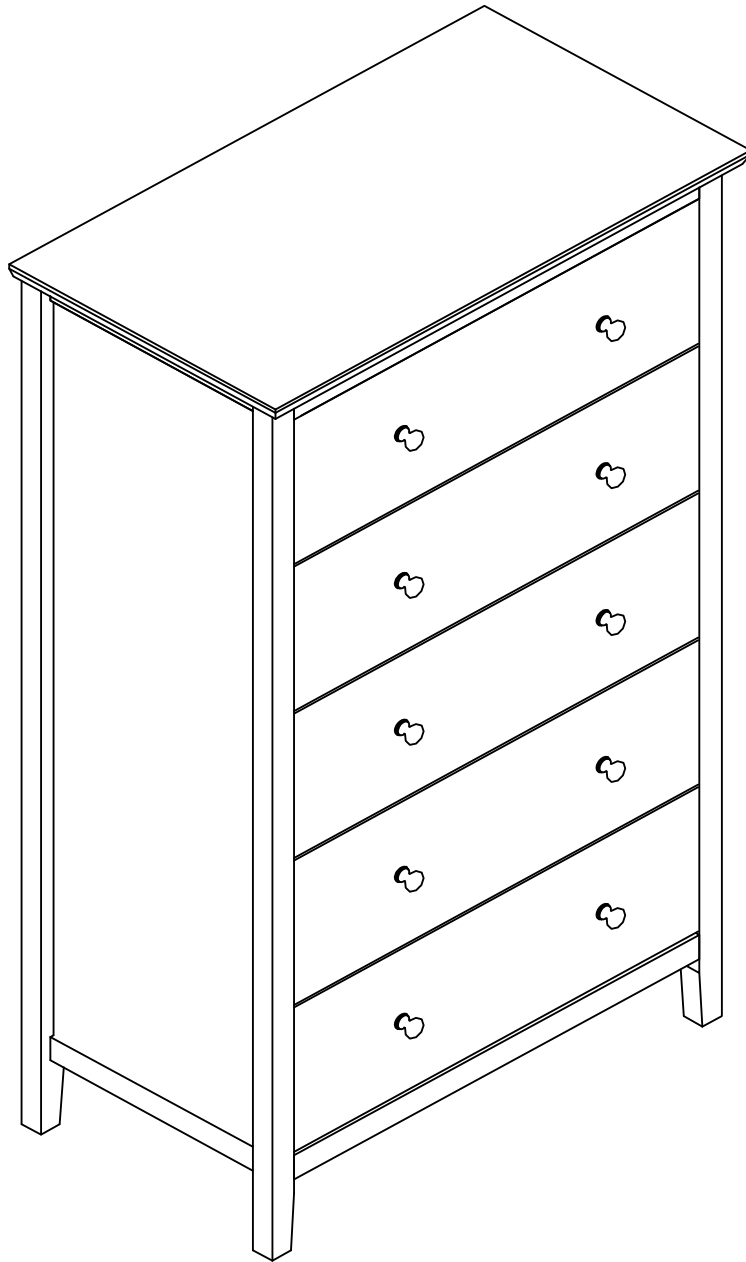

---

Description : 5 DRAWER CHEST RTA

Printed in Vietnam

## BEFORE ASSEMBLY

Thank you for purchasing this quality product. This product has been designed for easy assembly and constructed for durability. All parts were checked prior to packaging to insure quality. Prior to beginning assembly, however, make sure all parts and hardware are included and free of obvious defect. If a part is missing or defective, please contact the store where purchased.

### IMPORTANT NOTE:

- Place all wooden parts on a clean and smooth surface such as a rug or carpet to avoid the parts from being scratched.
- Remove all wrapping material, including staples & packing straps before you start to assemble.
- DO NOT tighten all screws and bolts until completely assembled.
- Keep all hardware parts out of reach of children.

### WARNING:

Long exposure to rubber or soft plastic may cause a chemical reaction and damage the finish of your product. Protect the surface of the product with cloth if you are using any product with rubber feet or base.

### ASSEMBLY TOOLS REQUIRED

NOT INCLUDED

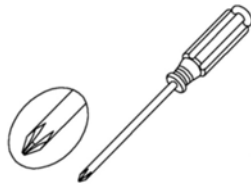





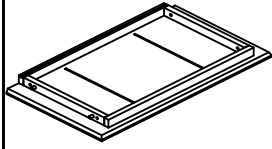
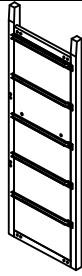
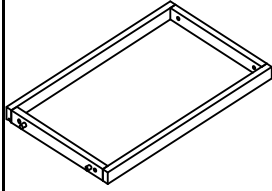
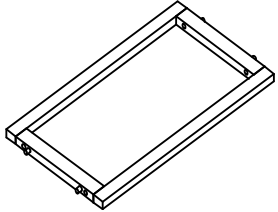
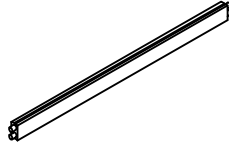
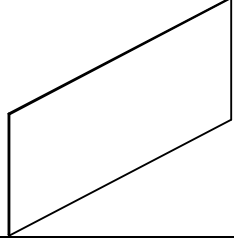
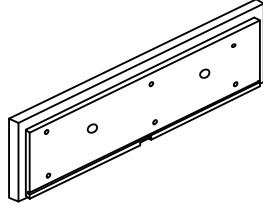
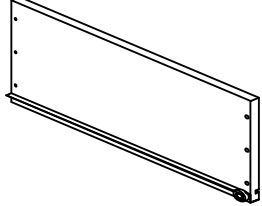
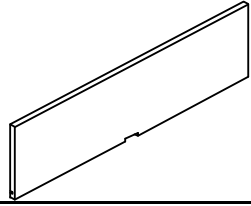
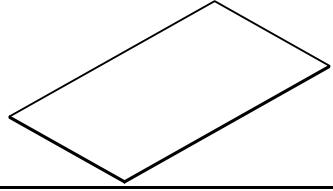
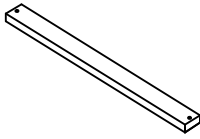

# PART LIST

When unpacking, please be careful not to discard any parts with the packaging. Before continuing, please make sure you have the following parts:

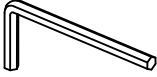
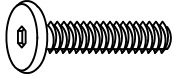
NO	Description	Qty	Sketch	NO	Description	Qty	Sketch
A	Top	1		B	Side panel	2 (L-R)	
C	Bottom panel	1		D	Center panel	1	
E	Back rail	2		F	Back panel	3	
G	Drawer front	5		H	Drawer side	10 (L-R)	
I	Drawer back	5		J	Drawer bottom	5	
K	Support bar	5					

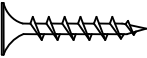
# HARDWARE LIST

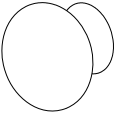
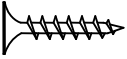
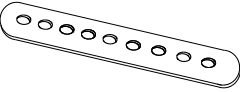
When unpacking, please be careful not to discard any parts with the packaging. Before continuing, please make sure you have all of the following hardware:

NO	Description	Qty	Sketch	NO	Description	Qty	Sketch
1	Allen key (M4x80mm)	1		2	Bolt (M6 X 30mm)	12	
3	Spring washer (Φ6.5x11mm)	12		4	Flat Washer (Φ6.5x13mm)	12	
5	Screw (M4 X 35mm)	65		6	Pan head screw (M4 x 30mm)	10	
7	Knob (Φ30x30mm)	10		8	Screw (M4 X 30mm)	10	
9	Steel band	1		10	Warning label	5	<div style="border: 1px solid black; padding: 5px; width: fit-content;"> <p style="text-align: center; margin: 0;"><b>WARNING!</b></p> <p style="text-align: center; margin: 0; font-size: small;">THIS ITEM IS PRONE TO TIPPING.</p> <p style="text-align: center; margin: 0; font-size: x-small;">USE ANTI-TIPPING HARDWARE (PROVIDED) TO SECURE TO THE WALL.</p> <p style="text-align: center; margin: 0; font-size: x-small;">DO NOT ALLOW CHILDREN TO CLIMB ON FURNITURE.</p> <p style="text-align: center; margin: 0; font-size: x-small;">PLACE HEAVIEST OBJECTS IN LOWER DRAWERS.</p> <p style="text-align: center; margin: 0; font-size: x-small;">DO NOT OPEN MORE THAN ONE DRAWER ON THE UNIT AT THE SAME TIME.</p> <p style="text-align: center; margin: 0; font-size: x-small;">DO NOT PLACE TV ON THE TOP OF THE DRESSER OR DRAWER CHEST.</p> </div>
11	Screw (M3 X 15mm)	2					

## STEP 1

Attach top (A), center panel (D), and bottom panel (C) to a side panel (B) with bolts (2) and washers (3) and (4). Tighten with Allen key (1).  
Slide back panel (F), and back rail (E) into the groove as shown below.

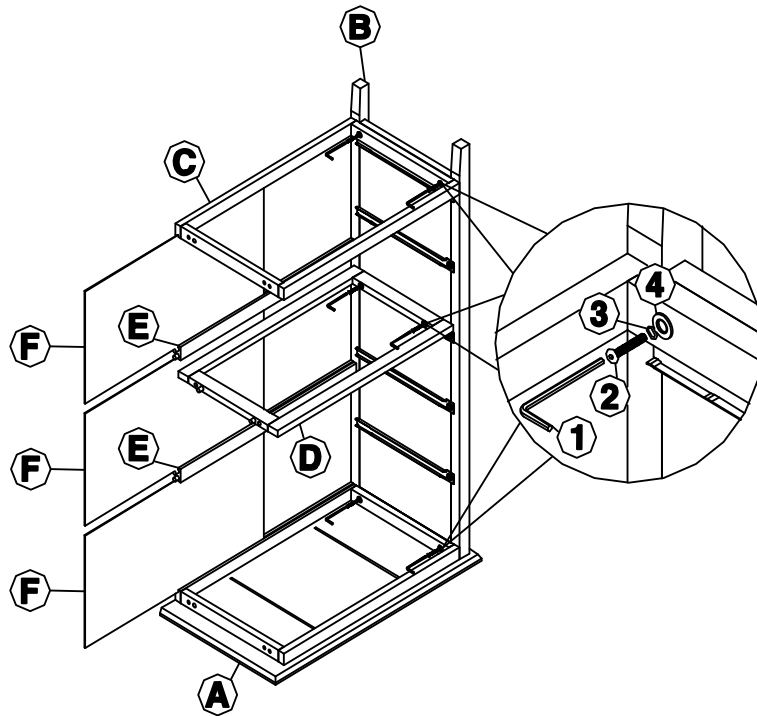

## STEP 2

Attach bottom panel (C), center panel (D), and top (A) to the other side panel (B) with bolts (2), and washers (3) and (4). Tighten with Allen key (1).

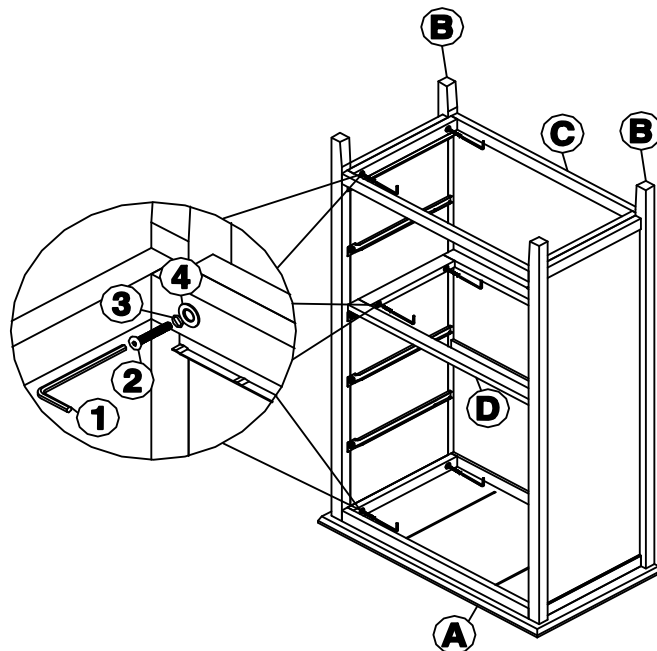

## STEP 3

Attach back rail (E) to side panels (B) with screws (5) .Tighten with a screwdriver.  
Attach the steel band (9) to Chest with screws (11) as shown below.

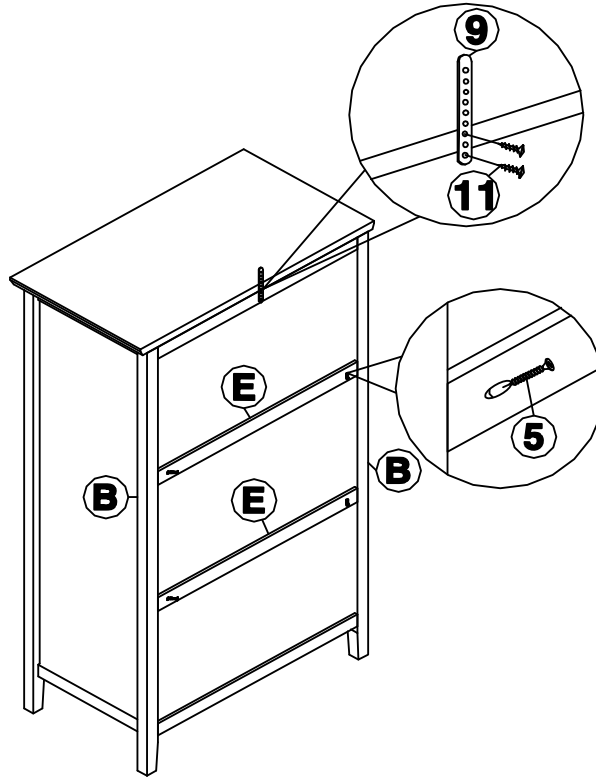

## STEP 4

Attach drawer sides (H) to drawer front (G) with screws (5). Tighten with a screwdriver  
Insert drawer bottom (J) into the grooves at bottom of drawer sides (H), and drawer front (G) as shown below.

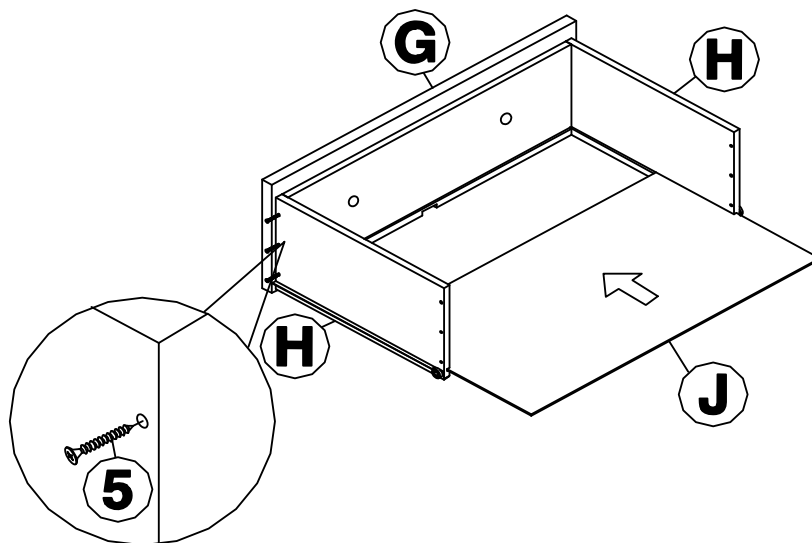

## STEP 5

Attach drawer back (I) to drawer sides (H) with screws (5) as shown below. Tighten with a screwdriver.

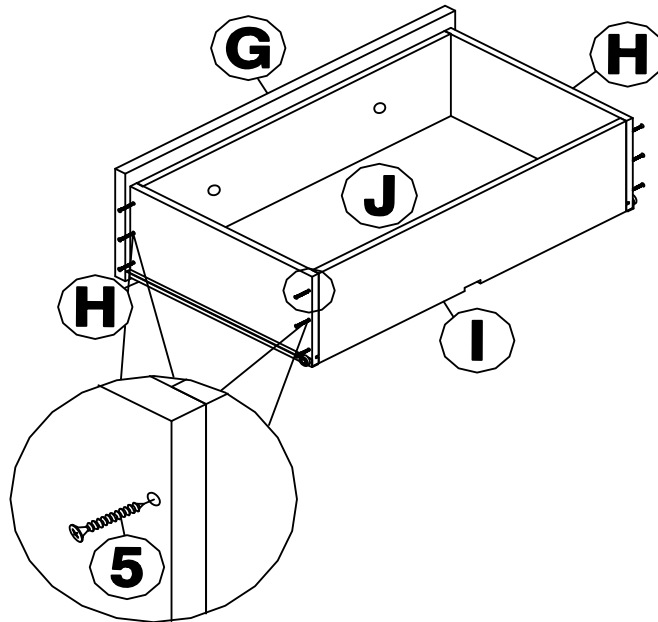

## STEP 6

Attach support bars (K) to bottom of drawers with screws (8) as shown below. Tighten with the screwdriver.

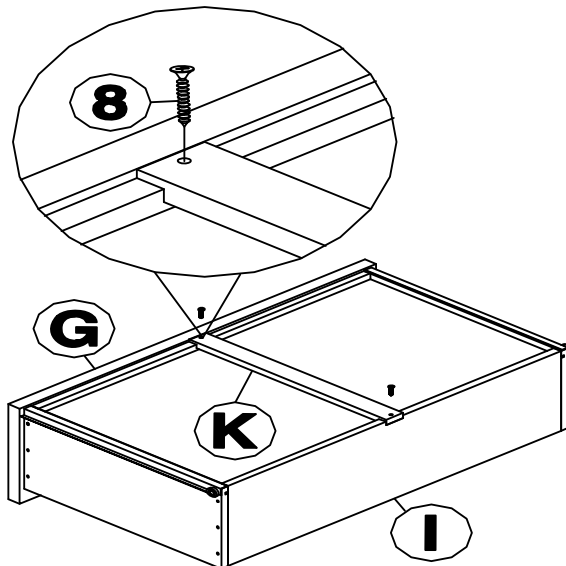

## STEP 7

Attach knobs (7) to front of drawers with screws (6). Tighten with the screwdriver.  
Stick the warning labels (10) inside the drawers before use

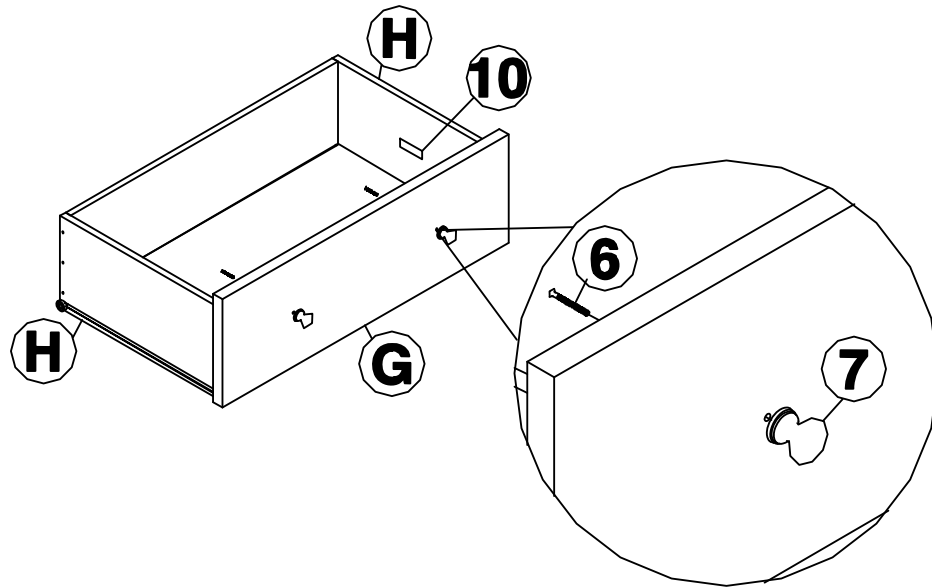

## STEP 8

Attach the steel band (9) to the wall with screws (5) as shown below (to secure the product and prevent tipping).

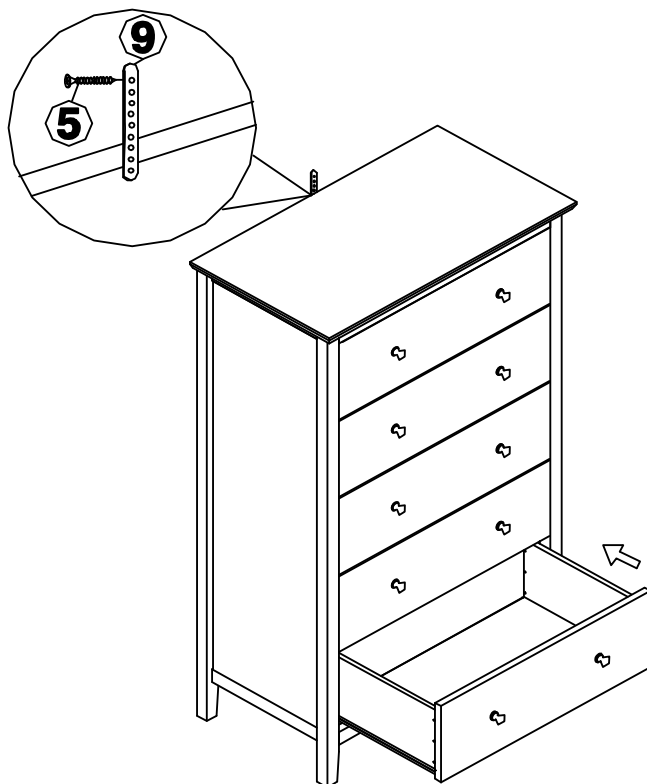

Printed in Vietnam