

Thank you for your purchase!

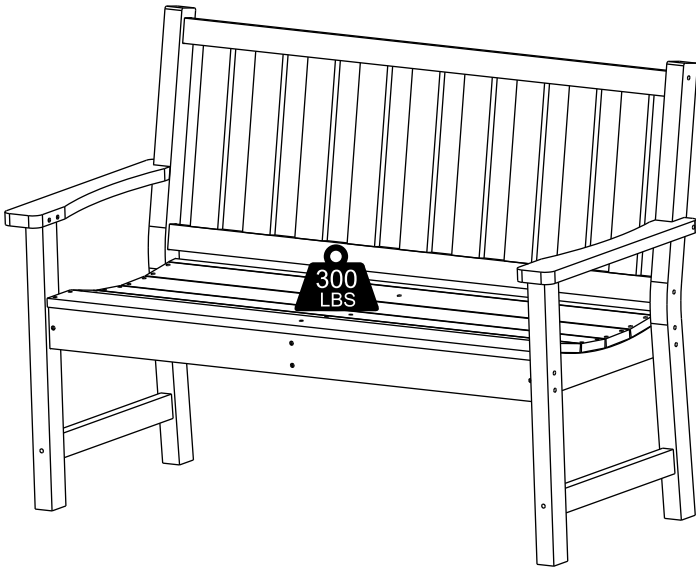

## Commercial Grade Indoor/Outdoor Bench

### ASSEMBLY INSTRUCTIONS

#### Before You Begin:

Please identify all component parts and hardware pieces required before you begin. Carefully remove all of the components from the packaging and set aside for assembly. Assemble on a soft surface to prevent scratching during assembly.

#### Caution:

Tighten all components securely before use. Failure to do so may result in personal injury. DO NOT use any sharp objects to open plastic wrapped components as damage to product or components may result.

#### Warning:

CHOKING HAZARD - Small Parts. Adult Assembly Required.







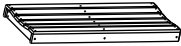

Injury may result from tipping furniture. You must install the Tipping Restraint Hardware with the unit to prevent the unit from tipping and causing any accidental injury, instability, death or damage. The tipping restraint is intended only as a safety measure, it is not a substitute for proper adult supervision.

This tipping restraint is not an earthquake restraint. If you wish to add the extra security of earthquake restraints, they must be purchased and installed separately.

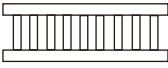
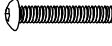
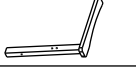
Serious or fatal crushing injuries can occur from furniture tipping over. To prevent furniture from tipping over it must be permanently fixed to the wall. Fixing devices for the wall are not included since different wall materials require different types of fixing devices. Use fixing devices suitable for the walls in your home.

Failure to detach this restraint before moving furniture may result in injury or damage.

DO NOT ALLOW CHILDREN TO CLIMB ON FURNITURE

<b>A</b>	 Seat	1pc	1	 Hex Bolt M6x60mm	14pcs
<b>B</b>	 Backrest	1pc	2	 Hex Bolt M6x70mm	4pcs
<b>C</b>	 Right Armrest & Leg	1pc	3	 Allen Wrench 5#	1pc
<b>D</b>	 Left Armrest & Leg	1pc			
<b>E</b>	 Connector	2pcs			
<b>F</b>	 Right Rear Leg	1pc			
<b>G</b>	 Left Rear Leg	1pc			

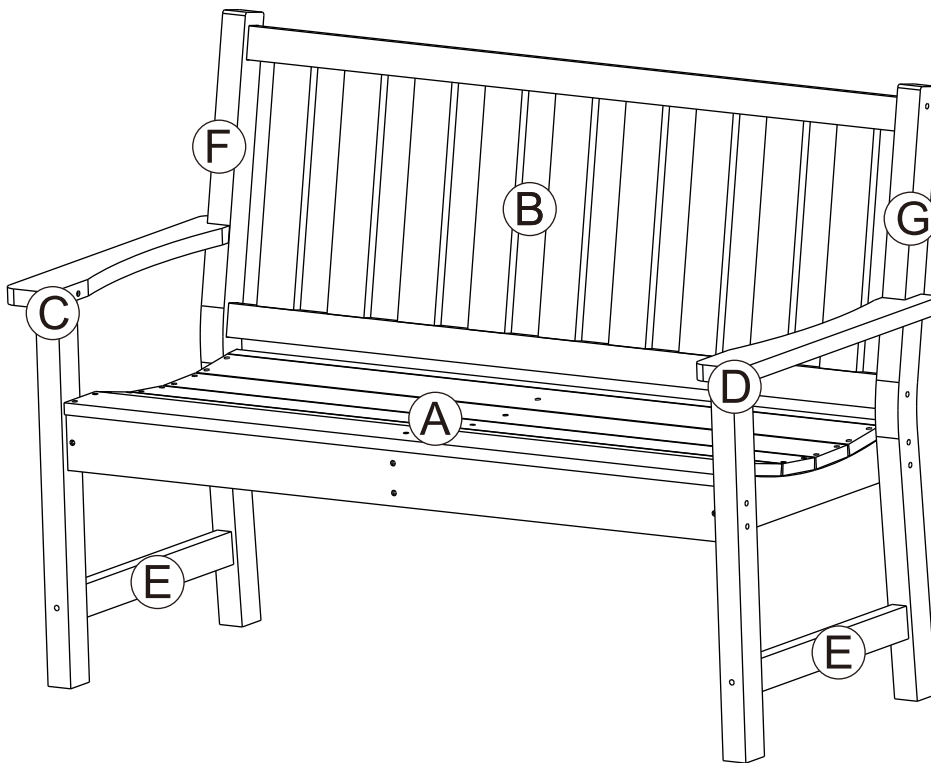

# STEP:1

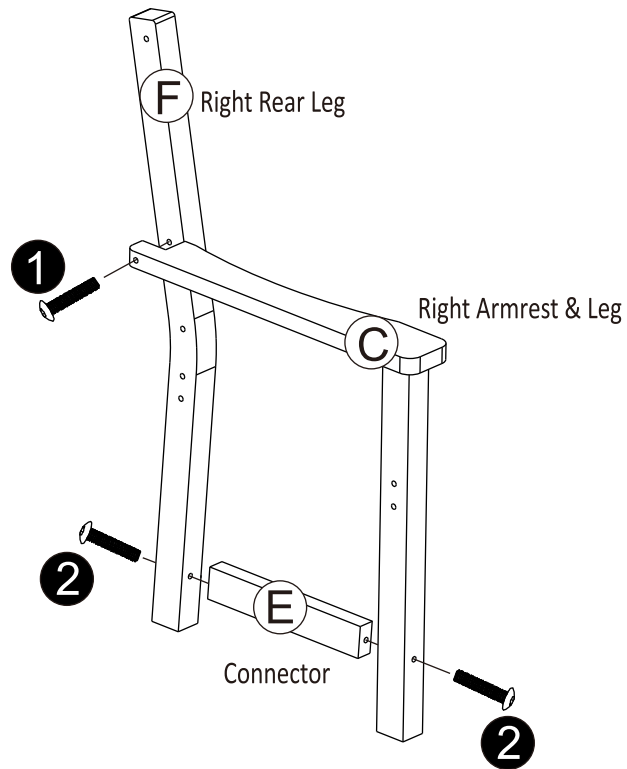

# STEP:2

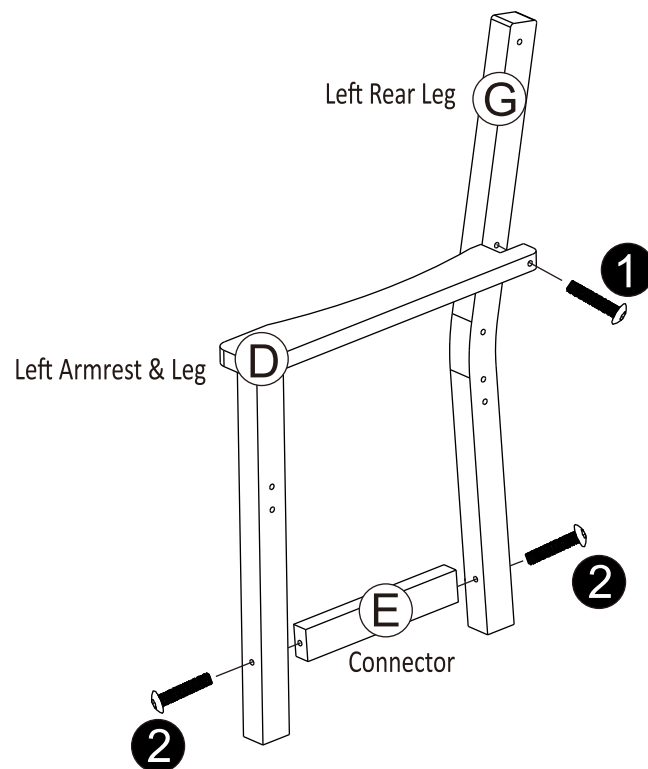

# STEP:3

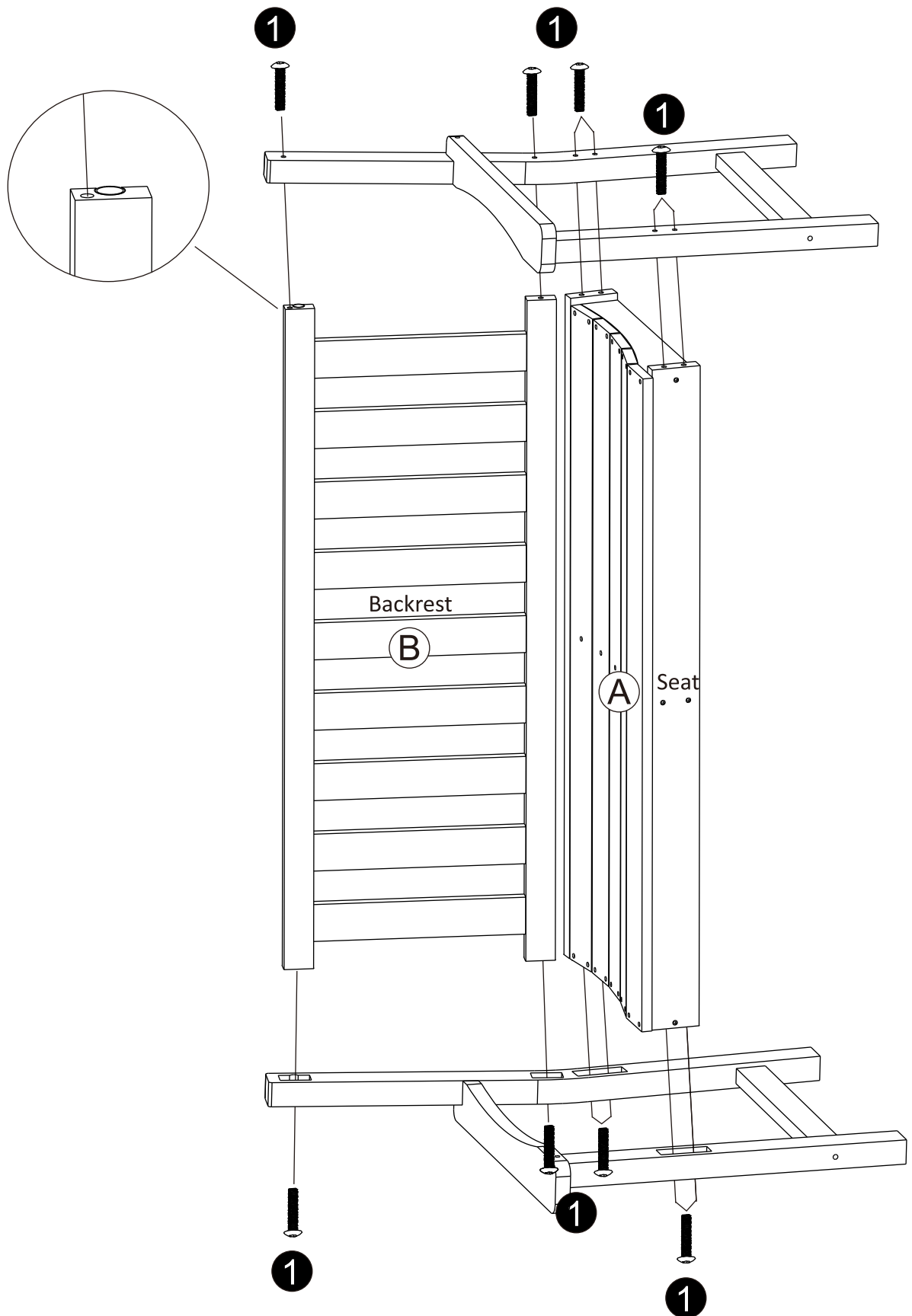

## Quality and Safety Guidelines:

- Please follow the static and dynamic weight capacity limits provided on this item. If you are unsure of the weight capacities for this product, email us
- Please use this item on a stable, level surface only. All bench feet/legs should contact the flooring surface when in use. Do not use this item if any instability is detected.
- Please take care to keep the chair stationary when lowering yourself into a seated position in this bench.
- Please inspect this product regularly to make sure there are no damaged or worn parts. Also inspect to make sure all hardware is tightened correctly and securely. For inspection instructions, please email us
- For maintenance instructions and replacement parts, please email us
- If any parts are damaged or worn, please stop using the product. Repair this product with manufacturer supplied parts only.
- This item is intended for sitting only, do not climb or stand on this item.
- This bench is not intended for significantly reclined positions. To prevent accidental tipping, do not push backward or forward while seated.
- Store indoors away from moisture. For additional storage instructions, please email us