

INSTRUCTION

Libro de instrucciones

INSTRUCTION

Istruzioni per l'installazione

ANWEISUNG

사용설명서 取扱説明書



*Two people for assembly
*Instalieren zwei Personen zusammen
*2人作業が必要です
*Deux personnes pour l'assemblage
*조립을 위해 두 사람 필요
*Due persone per il montaggio
*Dos personas para el montaje

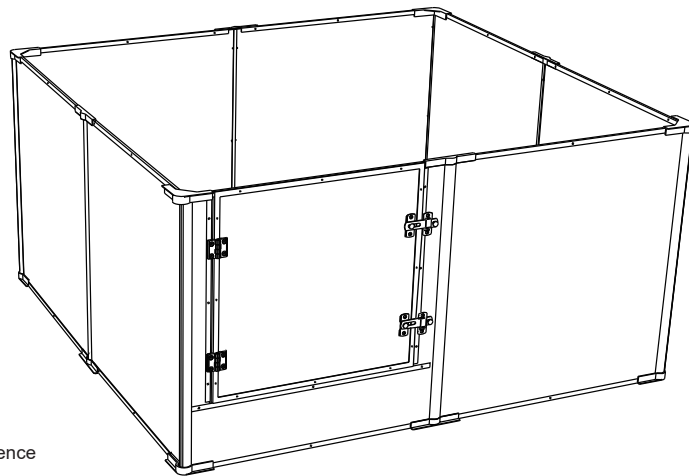

Product Name: Transparent fertility fence
XPETW-161B

Manufacturer: Yingbo Luo

Address:Tangkengwei Tangguang Village,Tangnan Town,
Fengshun County,Meizhou, Guangdong 514300

REPÚBLICA POPULAR DE CHINA

Country of origin:Made in China

Email:BingoPaw@wisfor.com

Warning:

This product is only suitable for pets.

Dieses Produkt ist nur für Haustiere geeignet.

Ce produit convient uniquement aux animaux de compagnie.

Questo prodotto è adatto solo agli animali domestici.

Este producto sólo es apto para mascotas.

本製品はペット以外、本来の用途以外に使用しないでください。

이 제품은 애완동물 전용입니다.

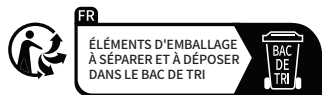

eVatmaster Consulting GmbH
Raiffeisen Street2B11,63110 Rodgau,
Hessen,Germany
contact@evatmaster.com

EU001733275636428rdNW

We simply act as an EU representative for cross-border sellers, and are not manufacturers/importers/distributors for the product, nor involved in the manufacture/import/sale of the product. There-fore, we are not responsible for any after-sales services related to the product. In case of any product quality or infringement issues, the manufacturer/importer/seller shall be solely held responsible.



Company:YH Consulting Limited
Address: C/O YH Consulting Limited Office 147,
Centurion House , London Road ,
Staines-upon-Thames , Surrey , TW18 4AX



A*3

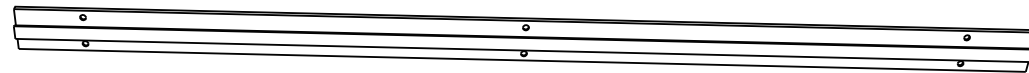

B*3

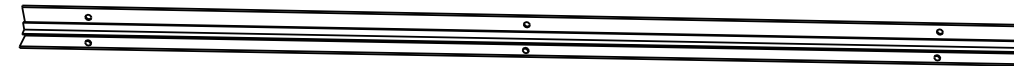

C*7

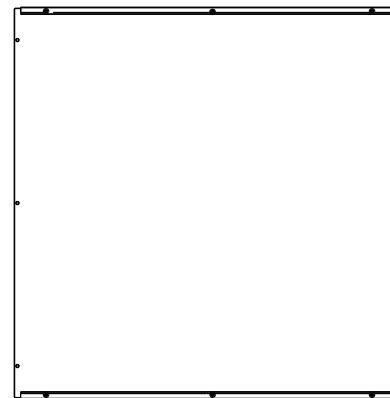

D*1

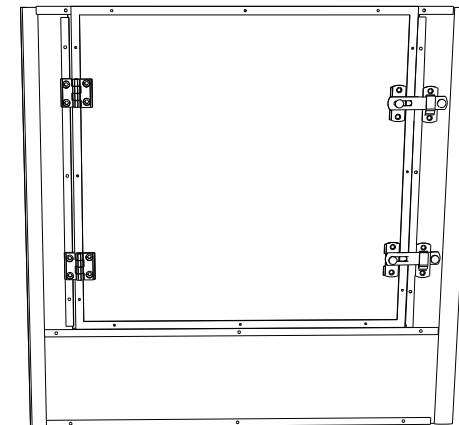

E*8

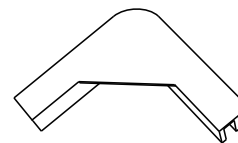

F*4



G*4



H*42



CM4*6

I*4



K*1

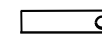

L*1

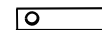

J*1





*This product is not recommended for use with extra-large pets weighing over 30KG.
 *Ce produit n'est pas recommandé pour les animaux de compagnie extra-lourds pesant plus de 30 kg.
 *Dieses Produkt wird nicht für übergroße Haustiere mit einem Gewicht von über 30 kg empfohlen.
 *Questo prodotto non è consigliato per animali domestici extra-large con un peso superiore a 30 kg.
 *Este producto no se recomienda para mascotas extragrandes que pesen más de 30 kg.
 *この製品は、体重が30KGを超える超大型ペットにはお勧めしません。
 *이 제품은 체중이 30KG를 초과하는 초대형 펫에게는 권장되지 않습니다.

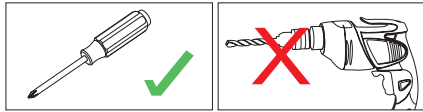

***do not use the electric drill for any other assembly.**
***Verwenden Sie den Elektrobohrer nicht für andere Montagearbeiten.**
***N'utilisez pas la perceuse électrique pour tout autre assemblage.**
***Non utilizzare il trapano elettrico per altri assemblaggi.**
***No utilice el taladro eléctrico para ningún otro ensamblaje.**
 *電動ドリルを他の組み立てに使用しないでください。
 *전동 드릴을 다른 조립에 사용하지 마십시오.

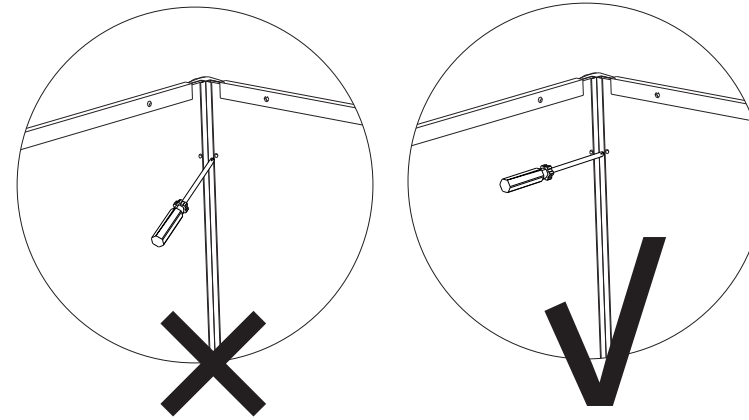

*** Note: When fixing the screws to the corner posts, keep the screwdriver handle perpendicular to the board.**
*** Hinweis: Halten Sie den Griff des Schraubendrehers beim Anbringen der Schrauben für die Eckpfosten senkrecht zur Platte.**
*** Nota: quando si installano le viti per i montanti d'angolo, mantenere l'impugnatura del cacciavite in posizione verticale rispetto al pannello.**
*** Remarque: Lors de l'installation des vis pour les poteaux d'angle, gardez le manche du tournevis perpendiculaire à la planche.**
*** Al instalar tornillos para postes esquineros, mantenga el mango del destornillador perpendicular al tablero.**
 * ご注意:スムーズに操作するため、ネジを回すとき、ドライバーのハンドルをボードに対して垂直に保ってください。
 * 주의: L형 기둥의 나사를 설치 시 드라이버는 판에 수직을 유지하면서 조립하십시오.

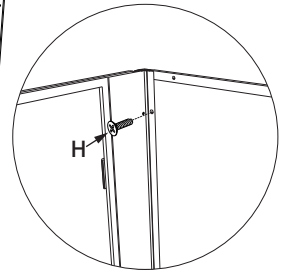
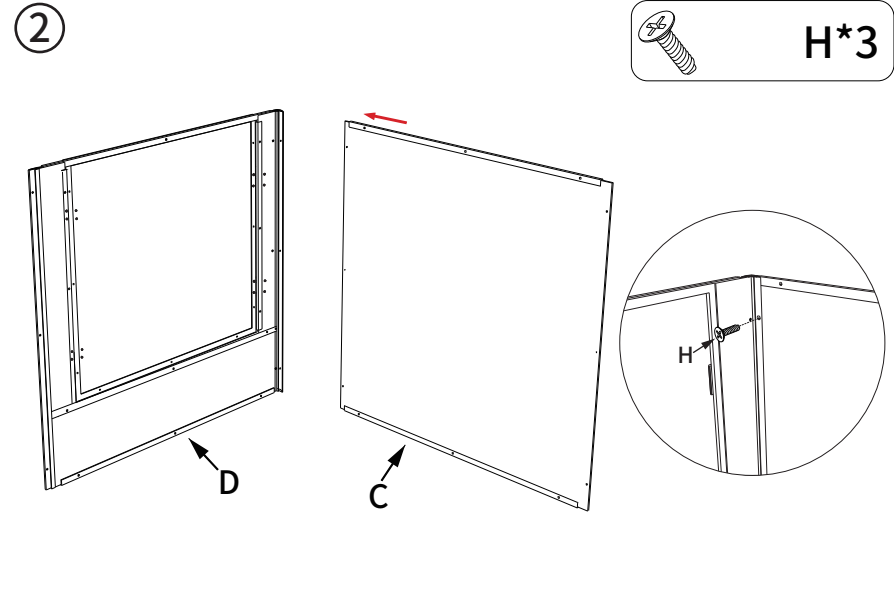
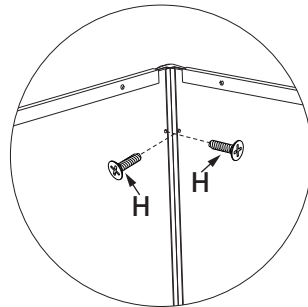
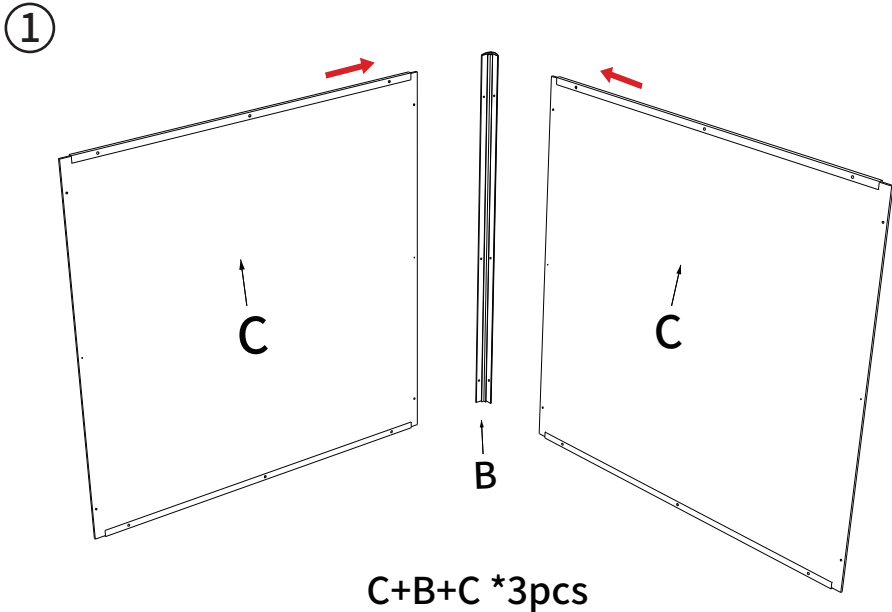

3

 H*21



*Two people for assembly
*Instalieren zwei Personen zusammen
*2人作業が必要です
*Deux personnes pour l'assemblage
*조립을 위해 두 사람 필요
*Due persone per il montaggio
*Dos personas para el montaje

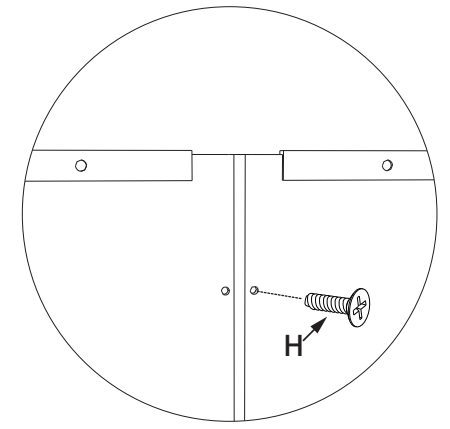
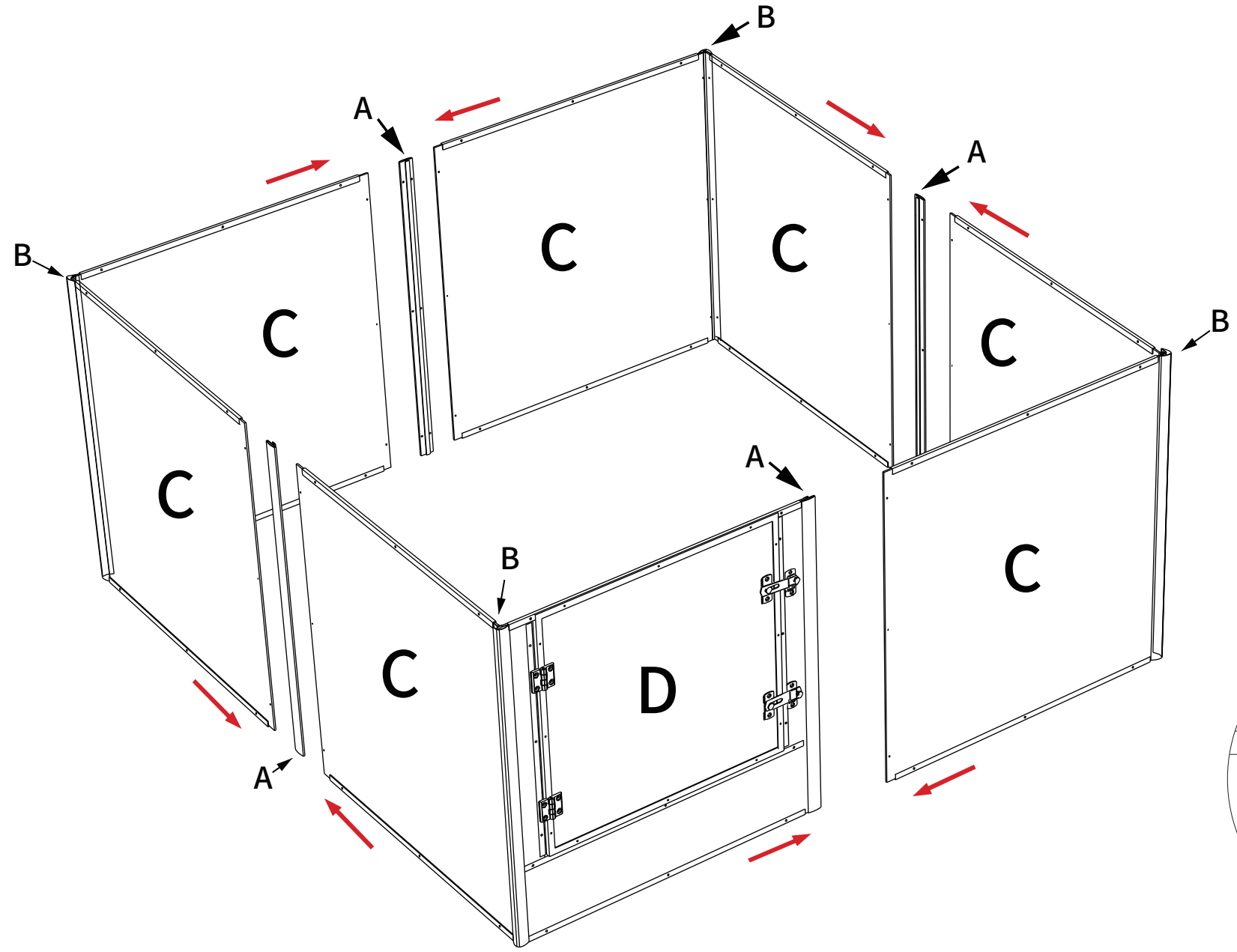

4

This installation method is recommended for large pets.
 Stabilere Montage für größere Haustiere.
 Pour les animaux de grande taille, ce mode d'installation est recommandé.
 Il grande animale da compagnia raccomanda questa installazione.
 Mascotas grandes recomiendan esta instalación.
 大型ペットの場合はこちらの設置方法をご参照ください。
 대형 애완동물은 이 설치 방식을 권장합니다.

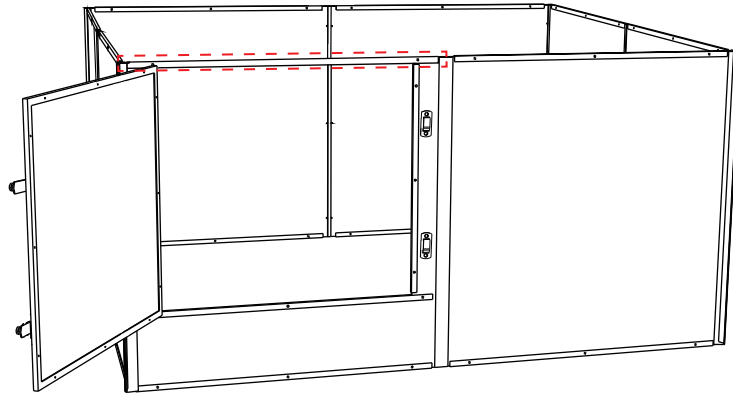

- *If cleaning is required, please remove this long rod.
- *Sie können die Querstange abnehmen, wenn Sie das Produkt reinigen müssen.
- *Si vous devez entrer pour nettoyer, veuillez démonter cette longue barre.
- *Se è necessario entrare per la pulizia, rimuovere il palo lungo.
- *Si necesita entrar para limpiar, retire esta barra larga
- *清掃のため入る場合は、長いポールを外してください。
- *들어가서 청소하시기 전에 이 긴 막대를 제거하십시오.

This installation method for small pets.
 Kleinere Haustiere können diese Montageart verwenden.
 Pour les petits animaux de compagnie, recommandent ce mode d'installation.
 Per gli animali domestici di piccola taglia si consiglia questa modalità di installazione.
 Para mascotas pequeñas, se recomienda este modo de instalación.
 小型ペットの場合はこちらの設置方法をご参照ください。
 소형견 사용할 경우 이 방식으로 설치하십시오.

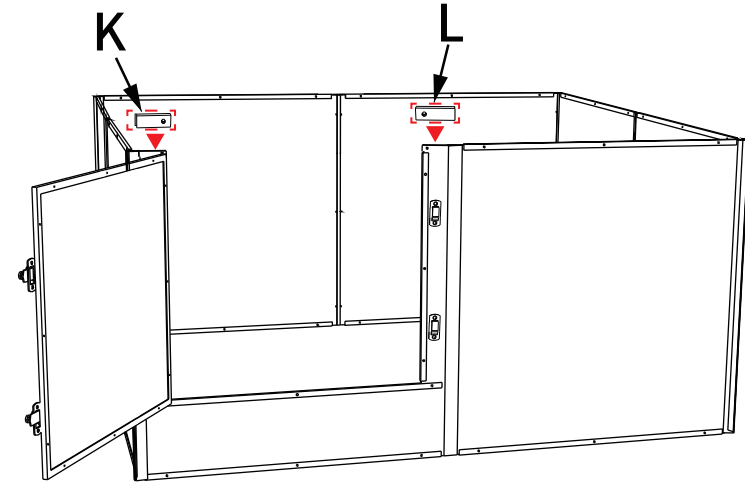

5

*Two people for assembly
 *Installieren zwei Personen zusammen
 *Deux personnes pour l'assemblage
 *조립을 위해 두 사람 필요
 *Due persone per il montaggio
 *Dos personas para el montaje

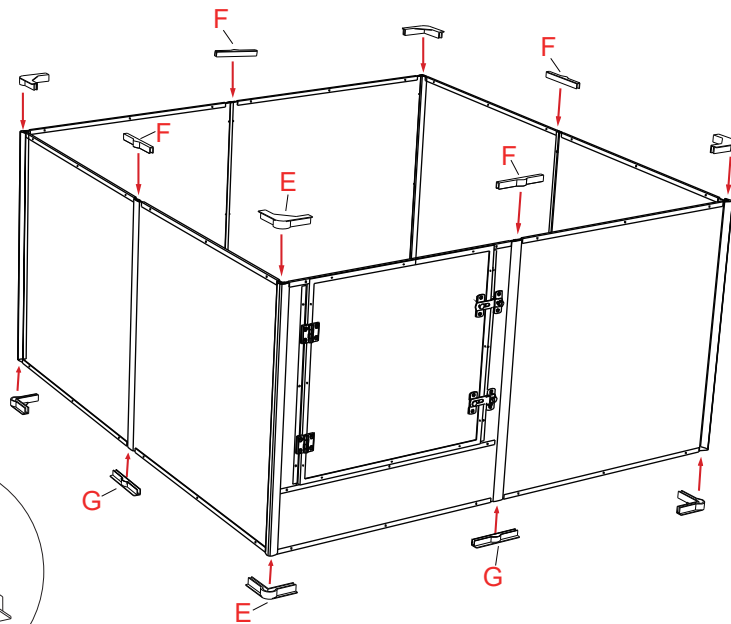

- E *8
- F *4
- G *4
- I *4

