

ASSEMBLY INSTRUCTIONS

STEP 3

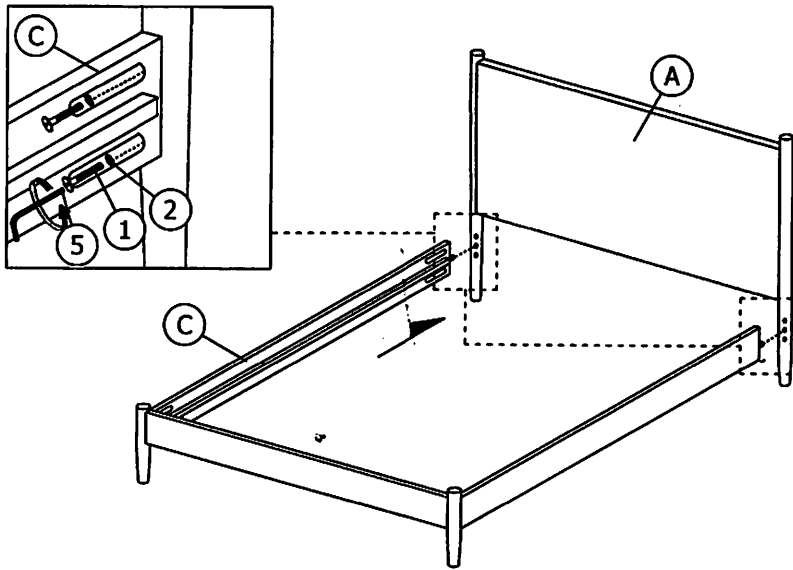

STEP 4

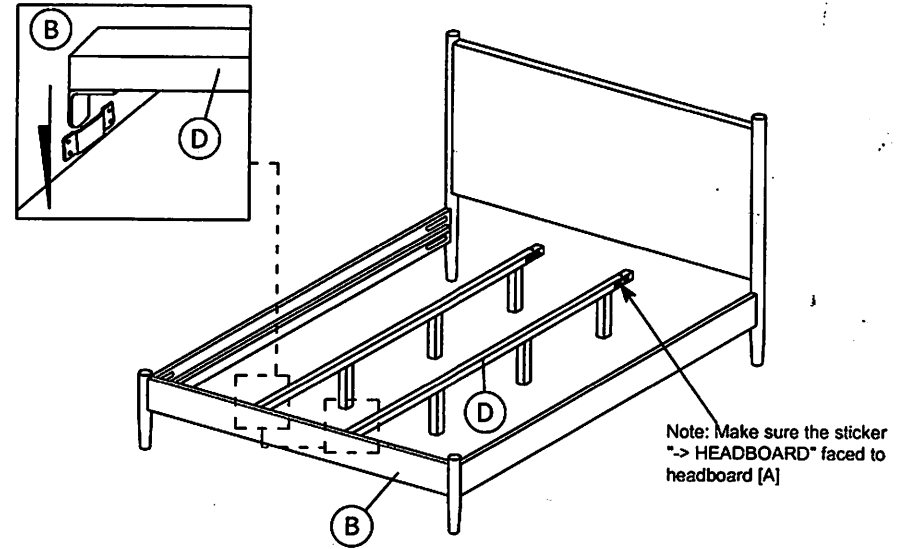

STEP 5

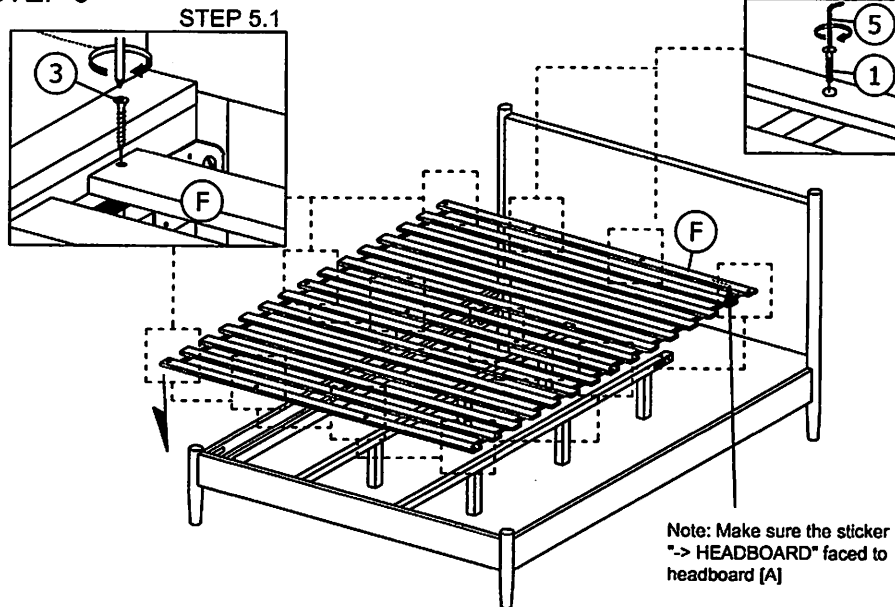

STEP 6

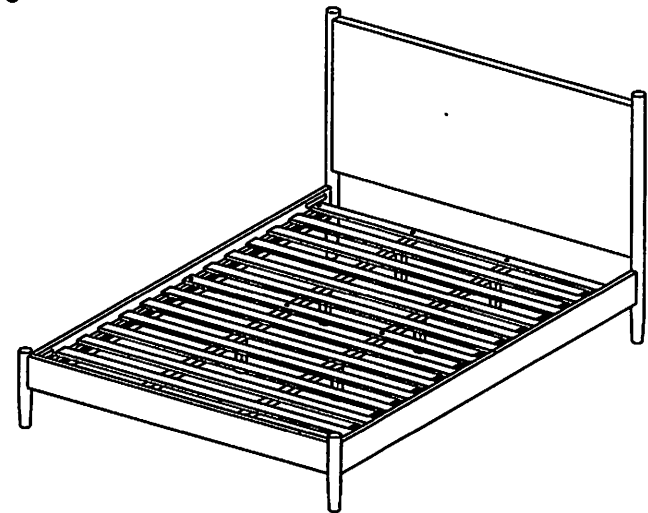

* When moving the bed position, the center support legs must be adjusted to be straight to avoid any damage.