

EXTERNALLY SILICONE SEAL THE WALL PROFILE WHERE IT MEETS THE WALL AND ALONG THE BOTTOM OF THE GLASS. ALL IN A CONTINUOUS BEAD.

DO NOT SILICONE INSIDE THE ENCLOSURE

ALLOW THE SILICONE AT LEAST 24 HOURS TO FULLY CURE.

AFTERCARE - ENSURE YOU CLEAN YOUR PRODUCT USING A MILD DETERGENT DILUTED IN WATER, REMOVING ANY RESIDUE WITH A SOFT DAMP CLOTH.

MAINTENANCE - ENSURE MOVING PARTS ARE FREE FROM ANY DEBRIS OR SOAP BUILD UP.

TROUBLE SHOOTING GUIDE

1. IS THE TRAY LEVEL (SEE STEP 1).
2. ARE THE WALL PROFILES PLUMB VERTICALLY (SEE STEP 2).
3. DO THE FINISHED TRAY MEASUREMENTS COMPLY WITH THE ADJUSTMENTS LISTED IN THE PRODUCT SPECIFICATION.

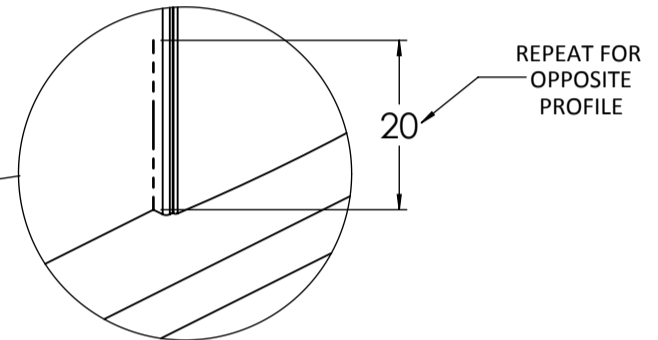

WETROOM SCREEN INSTRUCTION

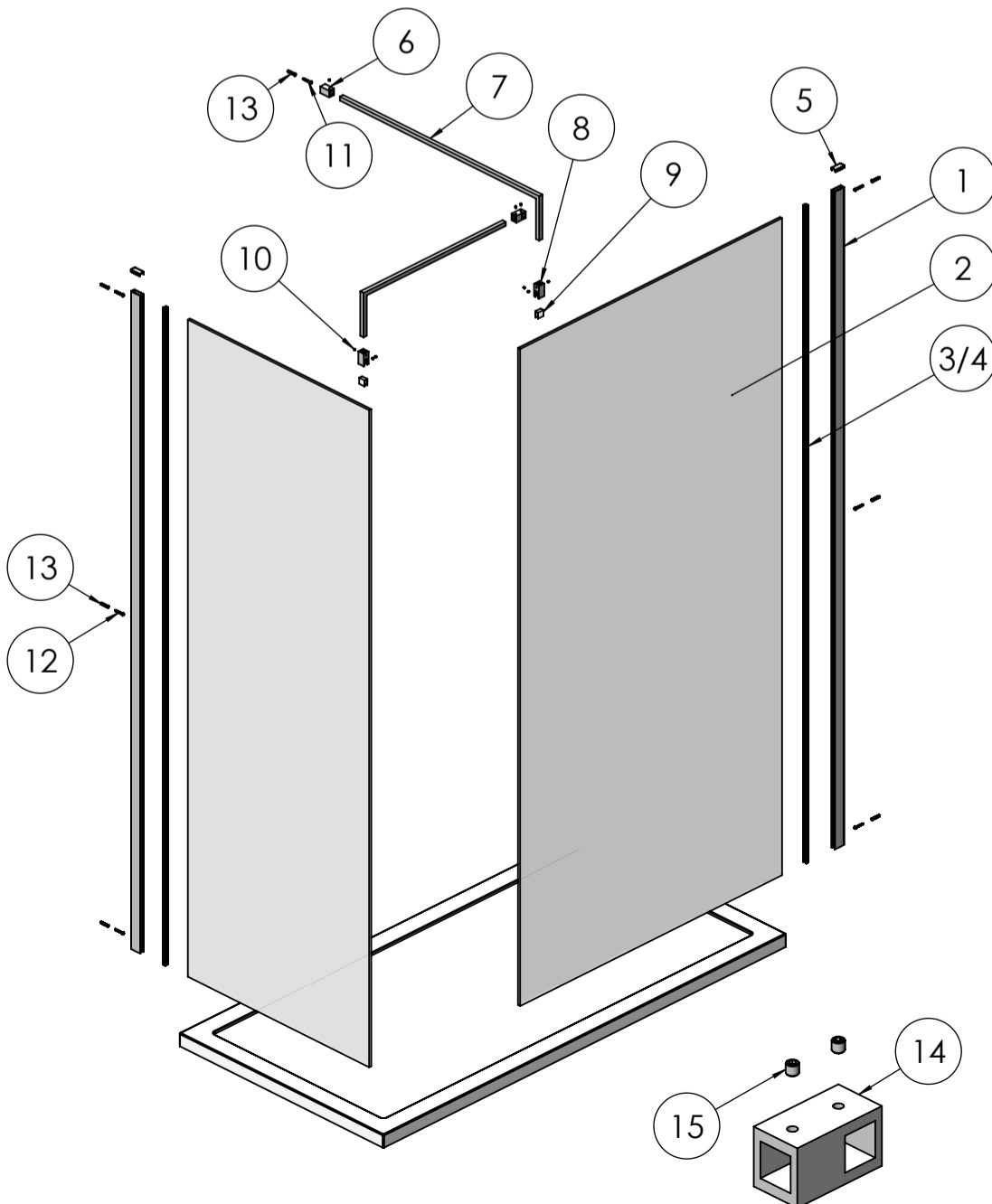

UNPACK THE BOX AND ENSURE ALL COMPONENTS ARE PRESENT.

NO REFUNDS OR REFITTING COST WILL BE GIVEN IF INCOMPLETE OR DAMAGED GOODS ARE FITTED.

THE TOUGHENED SAFETY GLASS SHOULD BE HANDLED WITH CARE AS IMPACTS WILL DAMAGE THE GLASS OR ENCLOSURE.

FIT THE SHOWER TRAY AS PER THE MANUFACTURERS INSTRUCTIONS.

NOTE: IF THE TRAY ISN'T TRUE AND LEVEL, IT MUST BE RECTIFIED BEFORE SILICONING AROUND THE TOP EDGE OF THE TRAY WHERE IT MEETS THE TILES. ALLOW THE SILICONE TO DRY BEFORE FITTING THE ENCLOSURE.

TOOLS REQUIRED

- POWER DRILL - 6mm MASONRY DRILL BIT
- CROSS HEAD SCREW DRIVER - TAPE MEASURE - PENCIL
- SILICONE GUN WITH SANITARY GRADE SEALANT - SPIRIT LEVEL.

FOR A SINGLE SCREEN			
ITEM	DESCRIPTION	Note	QTY
1	WALL PROFILE		1
2	SHOWER WALL GLASS		1
3	PUSH IN 'V' SEAL THICK	FOR 8mm GLASS	1
4	PUSH IN 'V' SEAL THIN	FOR 10mm GLASS	1
5	WALL PROFILE CAP		1
6	TOP BAR WALL SOCKET		1
7	TOP BAR		1
8	GLASS CLAMP		1
9	PVC SADDLE		1
10	GRUB SCREW		4
11	30mm CSK SCREW		1
12	30mm SELF TAPPER SCREW	FOR FIXING TO WALL	3
13	PLASTIC WALL PLUG		4

WALK-IN "T" PIECE SOCKET SET			
ITEM	DESCRIPTION	Note	QTY
14	"T" PIECE SOCKET		1
15	GRUB SCREW		2

1

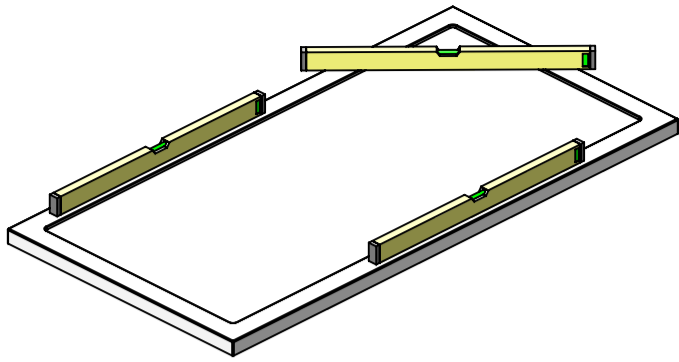

ENSURE THE TRAY IS LEVEL IN ALL PLANES.
IF THE TRAY IS NOT LEVEL IT WILL CAUSE FITTING ISSUES.

2

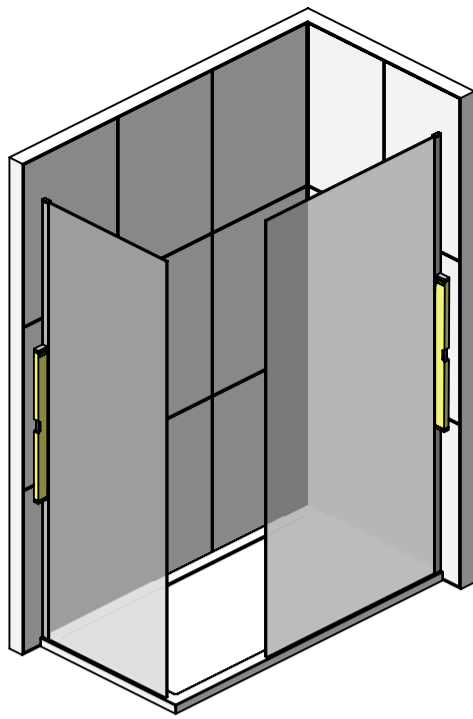

POSITION THE WALL PROFILES ON THE TRAY IN A SUITABLE POSITION. MAKE SURE THEY'RE TRUE WITH A SPIRIT LEVEL, THEN MARK THROUGH THE FIXING HOLES WITH A PENCIL. REMOVE PROFILES THEN DRILL AND PLUG THE WALL (ITEM 13). NOW FIX THE WALL PROFILE IN PLACE USING ITEM 12.

BEFORE FIXING ENSURE THAT THE CURVED FACE OF THE PROFILE IS FACING OUTWARDS FROM THE ENCLOSURE.

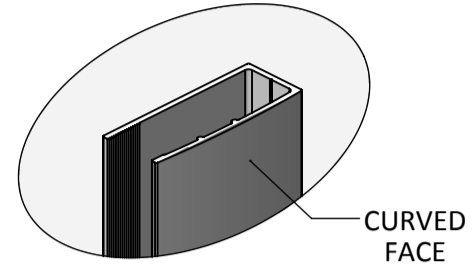

3

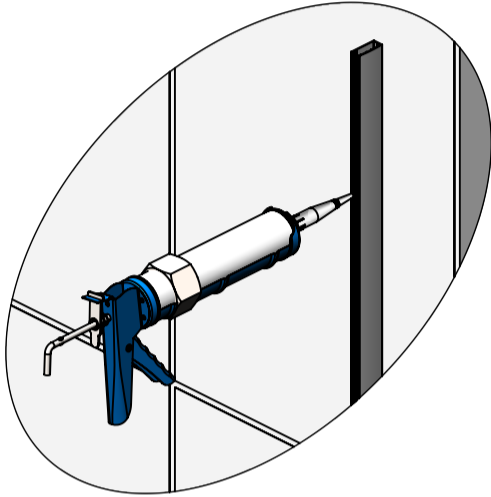

OPTIONAL
RUN A SMALL BEAD OF SILICONE DOWN THE INSIDE OF THE WALL PROFILES BEFORE FITTING GLASS. NOW SLIDE THE GLASS PANELS (ITEM 2) INTO THE PROFILES.

4

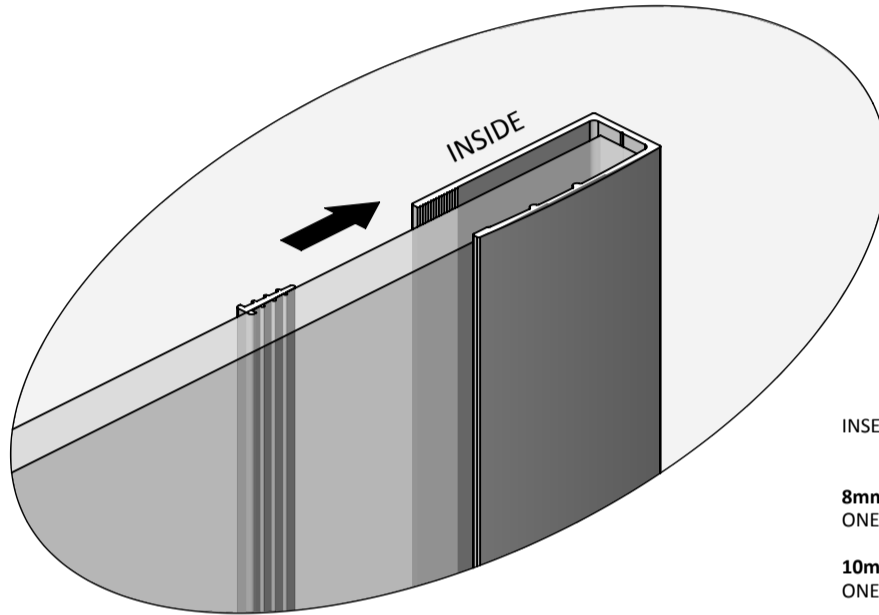

INSERT PUSH IN 'V' SEALS AS FOLLOWS:

8mm GLASS
ONE THICK SEAL ON THE INSIDE OF THE GLASS PANEL.

10mm GLASS
ONE THIN SEAL ON THE INSIDE OF THE GLASS PANEL.

5a SINGLE SCREEN

ASSEMBLE THE TOP BAR (SUPPLIED WITH SCREEN) AS PER THE DIAGRAM BELOW FOR A SINGLE SCREEN CUTTING BAR "A" TO REQUIRED LENGTH.

ASSEMBLE THE TOP BARS.

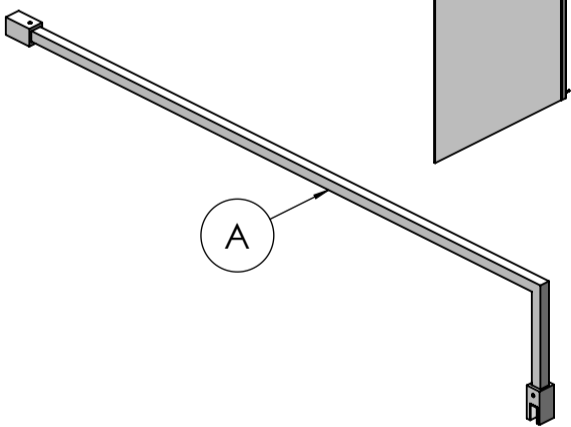

5b WALK-IN CONFIGURATION

ASSEMBLE THE TOP BARS (SUPPLIED WITH SCREEN) AS PER THE DIAGRAM ACROSS FOR A WALK-IN CONFIGURATION CUTTING BAR "A" TO REQUIRED LENGTH.

ENSURE BEFORE FIXING THE TOP BAR WALL SOCKET THAT YOU HAVE POSITIONED THE 'T' PIECE SOCKET (ITEM 14) ONTO BAR "A" WITH THE GRUB SCREWS (ITEM 15) FACING UPWARDS.

NOW MEASURE AND CUT BAR "B" TO SUIT.

ASSEMBLE THE TOP BARS.

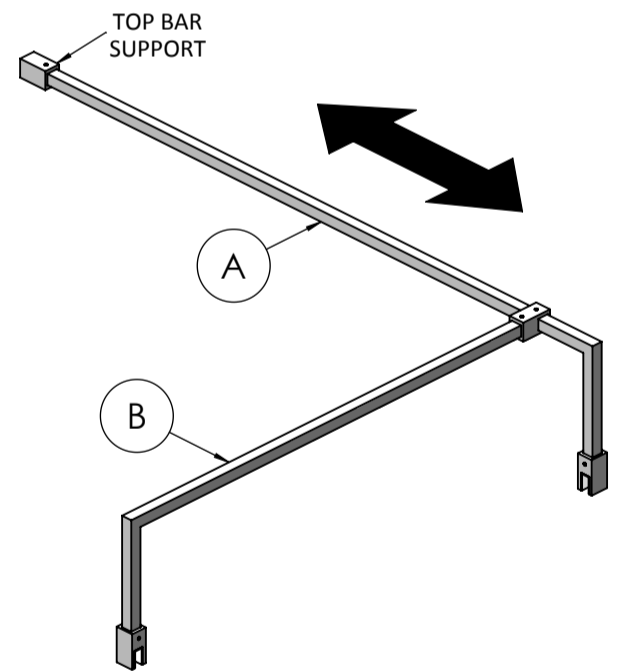
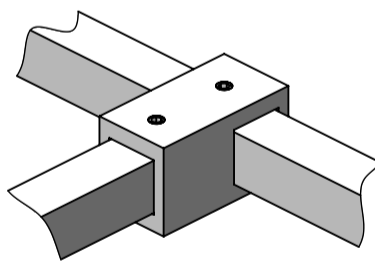

6

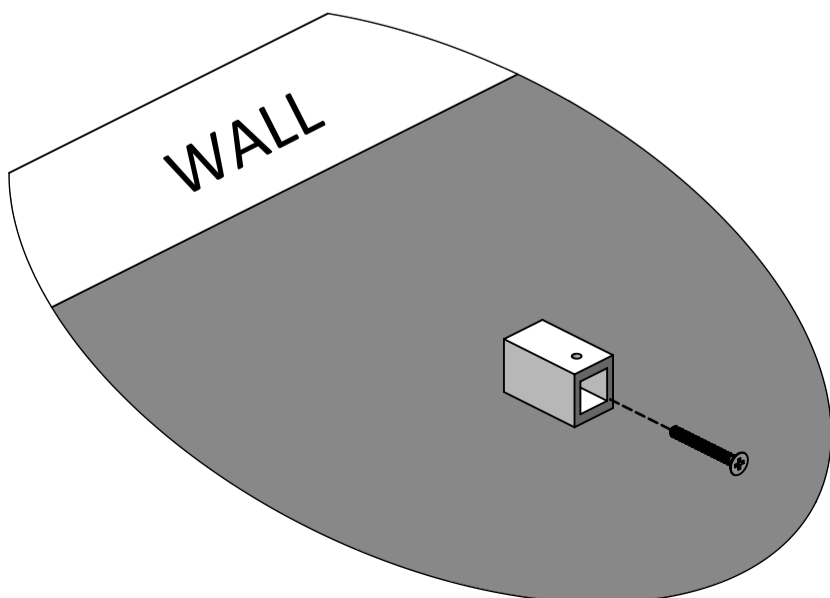

ONCE ASSEMBLED MARK AND DRILL THE TOP BAR WALL SOCKET (ITEM 6). ENSURE THE TOP BAR WALL SOCKET IS LEVEL AND THAT THE GRUB SCREW IS FACING UPWARDS BEFORE FIXING IT TO THE WALL USING ITEMS 11 & 13.

FIT BAR ASSEMBLY.

7

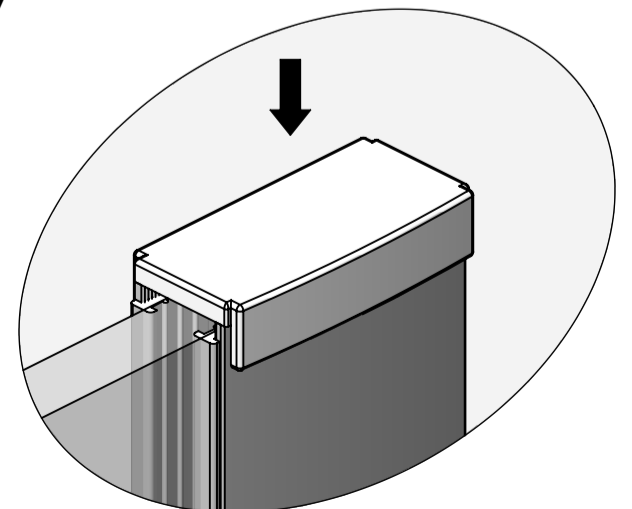

FINALLY FIT THE WALL PROFILE CAP (ITEM 5). A SMALL BLOB OF SILICONE CAN BE APPLIED TO THE UNDERSIDE OF THE CAP TO HOLD IT IN PLACE IF NECESSARY.