

4" TABLE SAW



Specifications

ITEM	DESCRIPTION
Motor	<input type="checkbox"/> 220V-230V AC;50Hz;at 4500 RPM;1/8HP;90Watts
	<input type="checkbox"/> 110V-120V AC;60Hz;at 4500 RPM;1/8HP;90Watts
Depth of Cut	5/8"
Table Size	190x142mm
Arbor Diameter	12mm
Blades (included)	4"Dry Diamond Blade
	4"Carbide Tipped Blade
Net Weight	7.3Lbs

Save This Manual

You will need the manual for the safety warning and precautions, assembly instructions, operating and maintenance procedures, parts list and diagram. Keep your invoice with this manual. Write the invoice number on the inside of the front cover. Keep the manual and invoice in a safe and dry place for future reference.

Safety Warnings and Precautions

WARNING:When using this tool,basic safety precautions should always be followed to reduce the risk of personal injury and damage to equipment.

Read all instructions before using this tool!

1. Keep work area clean.Cluttered areas invite injuries.
2. Observe work area conditions.Do not use machines or power tools in damp or wet locations. Don't expose to rain. Keep work area well lighted. Do not use electrically powered tools in the presence of flammable gases or liquids.
3. Keep children away. Children must never be allowed in the work area.Do not let them handle machines,tools,or extension cords.
4. Store idle equipment. When not in use, tools must be stored in a dry location to inhibit rust. Always lock up tools and keep out of reach of children.
5. Do not force fool.It will do the job better and more safely at the rate for which it was intended.Do not use inappropriate attachments in an attempt to exceed the tool capacity.
6. Use the right tool for the jod. Do not attempt to force a small tools or

Assembly Drawing

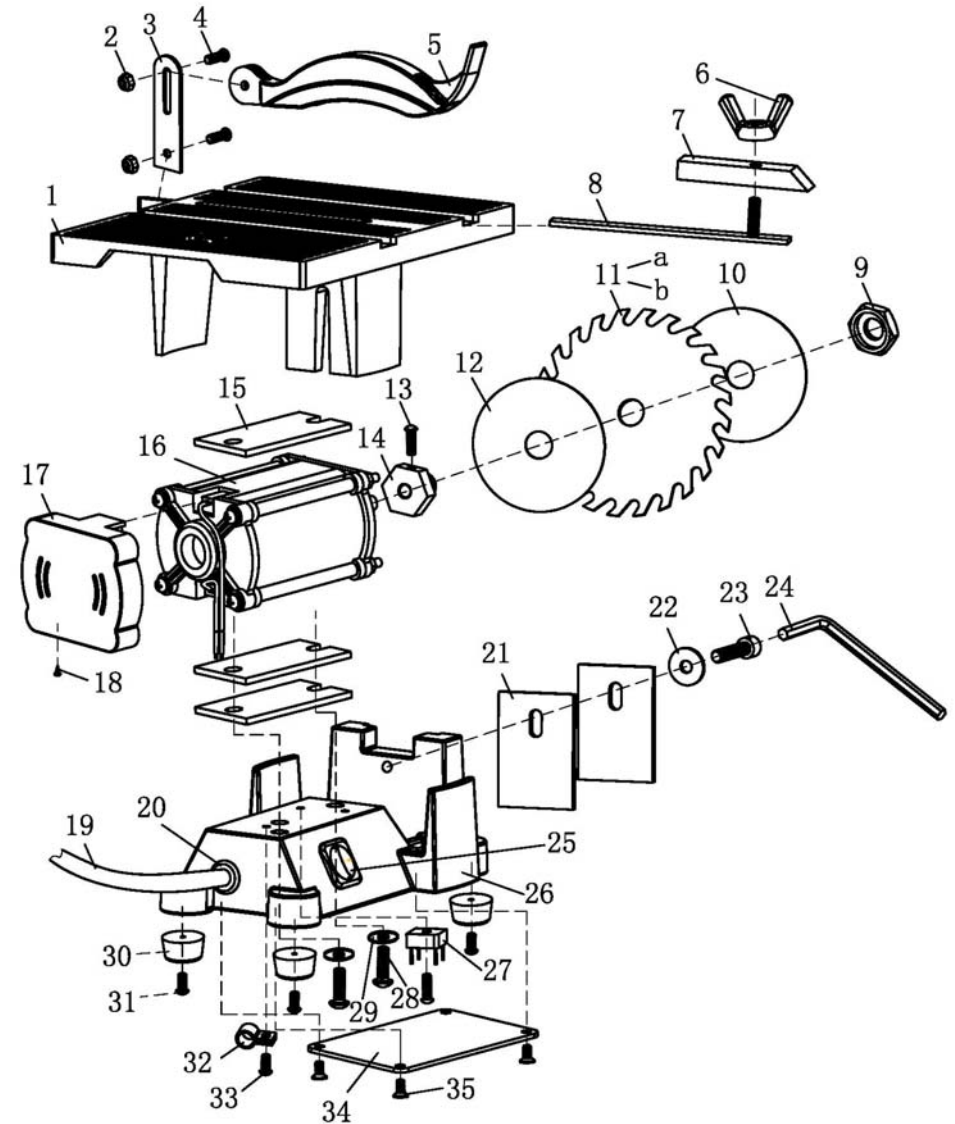

NOTE:Some parts are listed and shown for illustration purposes only and are not available individually as replacement parts.

Parts List

NO:	Description	Qty
1.	Table	1
2.	Screw Nut	2
3.	Guard Bracket	1
4.	Screw	2
5.	Protective Cover	1
6.	Wing Nut	1
7.	Straight Edge Guide	1
8.	Straight Edge Shaft	8
9.	Mounting Nut	1
10.	Rt.Blade Bushing	1
11.a	Carbide Saw Blade	1
11.b	Diamond Coated Blade	1
12.	Lt.Blade Bushing	1
13.	Screw	1
14.	Blade Spindle Lock Nut	1
15.	Vibration Absorption Pad	3
16.	Motor	1
17.	Motor Shell	1
18.	Screw	1
19.	Power Cord	1
20.	Cord Strain Relief	1
21.	Depth Adjustment Pad	2
22.	Washer	1
23.	Depth Adjustment Screw	1
24.	Depth Adjustment Wrench	1
25.	Power Switch	1
26.	Motor Base	1
27.	Bridge Rectifiers	1
28.	Screw	2
29.	Washer	2
30.	Foot	4
31.	Screw	4
32.	Pressure Line Board	1
33.	Screw	1
34.	Cover	1
35.	Screw	4

- attachment to do the work of a larger industrial tool. There are certain applications for which this tool was designed. Do not modify this tool and do not use this tool for a purpose for which it was not intended.
7. Dress properly. Do not wear loose clothing or jewelry as they can be caught in moving parts. Protective, electrically non-conductive clothes and non-skid footwear are recommended when working. Wear restrictive hair covering to contain long hair.
 8. Use eye and ear protection. Always wear ANSI approved impact safety goggles. Wear a full face shield if you are producing metal filings or wood chips. Wear an ANSI approved dust mask or respirator when working around metal, wood, and chemical dusts and mists.
 9. Do not overreach. Keep proper footing and balance at all times. Do not reach over or across running machines.
 10. Maintain tools with care. Keep tools sharp and clean for better and safer performance. Follow instructions for lubricating and changing accessories. Inspect tool cords periodically and, if damaged, have them repaired by an authorized technician. The handles must be kept clean, dry, and free from oil and grease at all times.
 11. Disconnect power. Unplug tool when not in use.
 12. Remove adjusting keys and wrenches. Check that adjusting wrenches are removed from the tool or machine work surface before plugging it in.
 13. Avoid unintentional starting. Be sure the switch is in the Off position when not in use and before plugging in.
 14. Stay alert. Watch what you are doing. Use common sense. Do not operate any tool when you are tired.
 15. Take caution as some woods contain preservatives such as copper chromium arsenate (CCA) which can be toxic. When cutting these materials extra care should be taken to avoid inhalation and minimize skin contact.
 16. Check for damaged parts. Before using any tool, any part that appears damaged should be carefully checked to determine that it will operate properly and perform its intended function. Check for alignment and binding of moving parts; any broken parts or mounting fixtures; and any other condition that may affect proper operation. Any part that is damaged should be properly repaired or replaced by a qualified technician. Do not use the tool if a switch does not turn On and Off properly.
 17. Guard against electric shock. Prevent body contact with grounded surfaces such as pipes, radiators, ranges, and refrigerator

enclosures.

18. Replacement parts and accessories. When servicing, use only identical replacement parts. Use of any other parts will void the warranty. Only use accessories intended for use with this tool. Approved accessories are available from Harbor Freight Tools.
19. Do not operate tool if under the influence of alcohol or drugs. Read warning labels on prescriptions to determine if your judgment or reflexes are impaired while taking drugs. If there is any doubt, do not operate the tool.
20. Use proper size and type extension cord. If an extension cord is required, it must be of the proper size and type to supply the correct current to the tool without heating up. Otherwise, the extension cord could melt and catch fire, or cause electrical damage to the tool. This tool requires use of an extension cord of 0 to 10 amp capability (up to 50 feet), with wire size rated at 18 AWG. Longer extension cords require larger size wire. If you are using the tool outdoors, use an extension cord rated for outdoor use. (Signified by "WA" on the jacket)
21. Maintenance. For your safety, service and maintenance should be performed regularly by a qualified technician.

Note: Performance of this tool (if powered by line voltage) may vary depending on variations in local line voltage. Extension cord usage may also affect tool performance.

Warning: People with pacemakers should consult with their physician(s) before using this product; operation of equipment in close proximity to a heart pacemaker could cause interference or failure of the pacemaker.

Warning: The warnings, cautions, and instructions discussed in this instruction manual cannot cover all possible conditions and situations that may occur. It must be understood by the operator that common sense and caution are factors which cannot be built into this product, but must be supplied by the operator.

WARNING: Some dust created by power sanding, sawing, grinding, m drilling, and other construction activities, contain chemicals known [to the State of California] to cause cancer, birth defects or other reproductive harm. Some examples of these chemicals are:

- *Lead from lead-based paints
- *Crystalline silica from bricks and cement or other masonry products
- *Arsenic and chromium from chemically treated lumber

Your risk from these exposures varies, depending on how often you do this type of work. To reduce your exposure to these chemicals: work in a well ventilated area, and work with approved safety equipment, such as those dust masks that are specially designed to filter out microscopic particles. (California Health Safety Code 25249.5,

et sep.)

Unpacking

When unpacking, check to make sure all parts listed on page 6 are included.

If any parts are missing or broken, please call Harbor Freight Tools at the number on the cover of this manual.

Changing/Replacing/Installing the Blades

1. Be sure the Table Saw is unplugged before you begin installing or changing the accessories.
2. You will need two adjustable Wrenches (not included) to install, change or replace the Blades. Use one wrench to hold the Blade Spindle Lock Nut [14] in place and the other wrench to turn the Mounting Nut [9]. See Assembly Diagram on Page 7.
3. Remove the Mounting Nut and the Right Blade Bushing [10]. Slide the Blade [11a,b] over the arbor, in line with the Left Blade Bushing [12]. Replace the Right Blade Bushing and the Mounting Nut. Tighten with the wrench.

Operation

1. Place your Table Saw on a flat, level surface capable of supporting weight of Table Saw and material being cut before use. Always wear ANSI- approved safety goggles when operating this tool.
2. Mark your work pieces with a pencil or other writing instrument before you begin cutting. Loosen the wing nut [6] on the Straight Edge Guide [8] and turn the Guide to the appropriate angle for your specific cutting requirements. Tighten the wing nut to hold the Guide in place.
3. Plug in the power Cord [19].
4. Lift the Eye Guard [5] and slide the Straight Edge Guide out far enough to allow you to lay your work piece flat on the Table [1]. Lower the Eye Guard onto your work piece. Never attempt to operate this tool without the Eye Guard [5] in place.
5. Flip the Power Switch [25] to the On position.
6. Using the Straight Edge Guide to hold your work piece steady, gently feed your work piece toward the Blade. Keep your fingers and all other body parts away from the Blade at all times. If your work piece is particularly small, you may want to use another small piece of wood or other material to push your work piece toward the Blade. Do not push forcefully against the Blade, or use materials that are particularly difficult to cut. If the Blade slows down as you are feeding your work piece toward it, you are pushing too forcefully, or the material is too hard for this tool to cut.