

LC137

GALVANIZED METAL GAZEBO

10 × 12

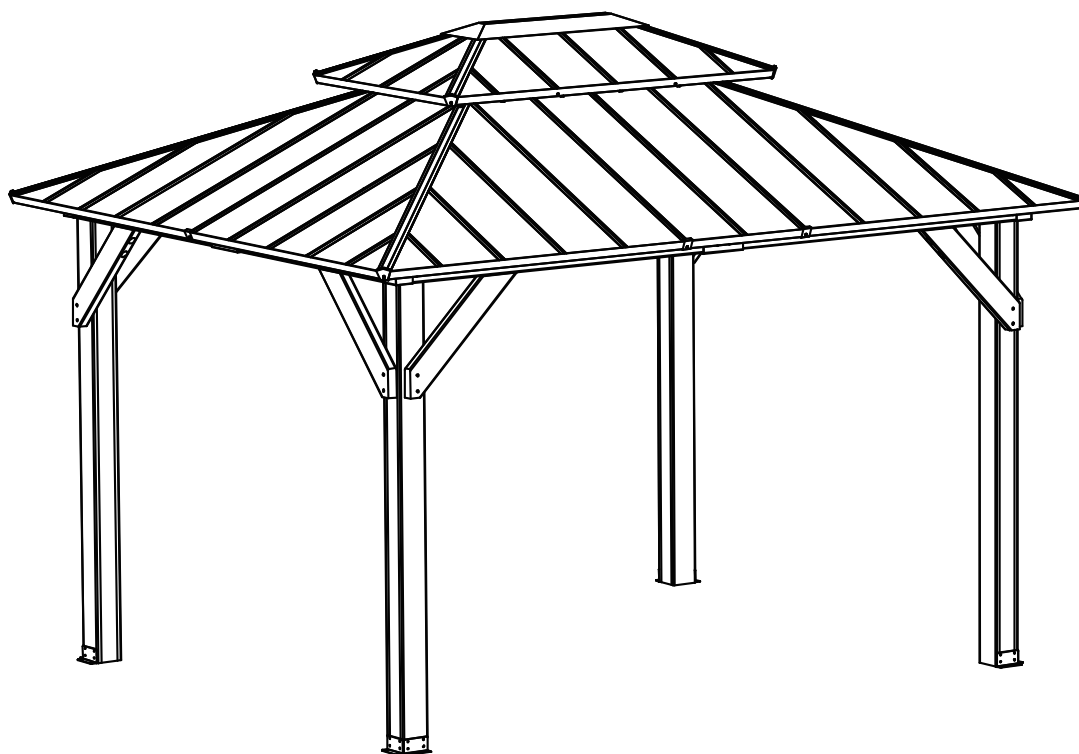

SKU: T-GZB25-1259-120BG

This warranty covers defects in materials or workmanship for a period of 1 year from the original date of purchase. Replacement parts may be provided after review and examination by our Consumer Support. **Proof of purchase and defect is required.**











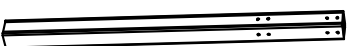









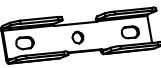

Please contact our Consumer Support for guidance before returning the gazebo.













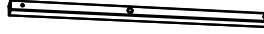

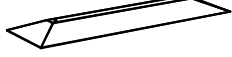



We strongly advise that you save and thoroughly read the manual instructions prior to using the gazebo. This warranty is exclusively valid for the original purchaser and cannot be transferred to any subsequent owners. To ensure the safety and longevity of the gazebo, it is essential to take necessary precautions during setup and regular usage. Additionally, adhering to the care and maintenance tips provided in the manual will greatly assist in preserving the quality and functionality of the gazebo.



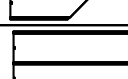







Warranty Exclusions:



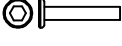

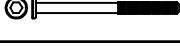

- Normal wear and tear, accidental or deliberate damage, abuse, misuse, or non-compliance with product instructions.
- Damage from inclement weather conditions, including wind, rain, hail, snow, or extreme temperature fluctuations.
- Gazebo purchased through non-authorized dealers or online auction websites.
- Altered or modified gazebo.
- Personal loss, injury, or indirect damages resulting from product use.
- Fading or deterioration due to prolonged exposure to UV rays.
- The conditions in some regions can be particularly harsh on the gazebo regardless of their type.

E-mail: hofficeservice@gmail.com

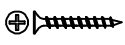
A		4
B1		2
B2		2
B3		2
B4		2
C		8
F1		4
F2		8
F3		6
F4		4
G1		4
G2		6
G3		6
G4		4
G5		4
G6		2
G7		4
J1		2
J2		2
J3		4
J4		4
J5		2

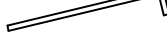
K1		4
K2		4
K3		6
K4		4
L1		1
L2		1
M		4
N1		8
N2		2
P1		4
P2		4
P3		4
P4		4
P5		4
P6		4
P7		6
P8		2
Q1		2
Q2		2
S		8

H1		M6X15	194
H2		M6X25	17
H3		M6X40	11
H4			2
H5		M6X40	16
H6		M8X60	42
H7		M8X120	8
H8		M6X16	222
H9		M8X18	84
H10		RUBBER	2
H11		M4X16	9

H12		M4X25	72
H13		M4X40	34
H16			37
HQ1			8
HQ2		M8X70	8
HW1		4MM-100	2
HW3		10-14	2
			4

Before beginning the assembly process, we recommend that you familiarize yourself with the product. Ensure that all parts listed in the packing list are included. If any parts are missing or damaged, please do not proceed with installation and contact us immediately.

Do not attempt to install the gazebo by yourself. Contact a professional if:

- You are unsure whether the chosen installation location is suitable.
- You do not understand any part of the instruction manual.
- You lack the necessary tools.
- You do not have the required technical knowledge.

A minimum of two healthy adults is required to move and install the gazebo.

Keep children and pets away from the assembly and work area.

This product and its components are only suitable for installation on a stable, flat surface like a cement wall or solid brickwork. If the wall or brickwork is cracked, consult a professional before proceeding.

Do not alter the design or structure of the gazebo without prior approval from the manufacturer or an authorized representative.

Make sure your hands are clean during assembly to avoid soiling the frame or gazebo top.

Do not climb on the gazebo. Hanging heavy items from it is strictly prohibited.

This structure is non-permanent. The warranty does not cover damage caused by extreme weather conditions, including heavy rain, high winds, or excessive heat from heaters or BBQs.

Never leave children unsupervised around or underneath the gazebo.

Do not attempt to assemble or use the gazebo in moderate to heavy wind conditions.

Never set up or use the gazebo during rain, wind, or stormy conditions, especially during lightning storms. Severe damage may occur, and there is a risk of injury.

Always follow safety precautions during assembly and use to minimize the risk of personal injury and equipment damage.

Please read all instructions carefully before assembly and use.

Sorting Parts

We recommend that you have a separate table to organize the hardware. You can organize your hardware by part number or group by hardware type (i.e. bolts, nuts, etc.). Refer to the part number carefully during assembly.

Tools Required



Electric
Drill



Tape
Measure



Hammer



Ladder

Attention:

1. Secure all screws loosely at first-do not tighten them completely. Once the assembly is fully completed, tighten all screws at the end.
2. Before beginning installation, make sure the area is cleared and the ground is flat and stable.
3. Some parts might have sharp edges/corners. Please follow basic safety precautions
4. Ensure all components are securely fastened according to the instructions, including anchoring it firmly to the ground to prevent tipping or displacement.

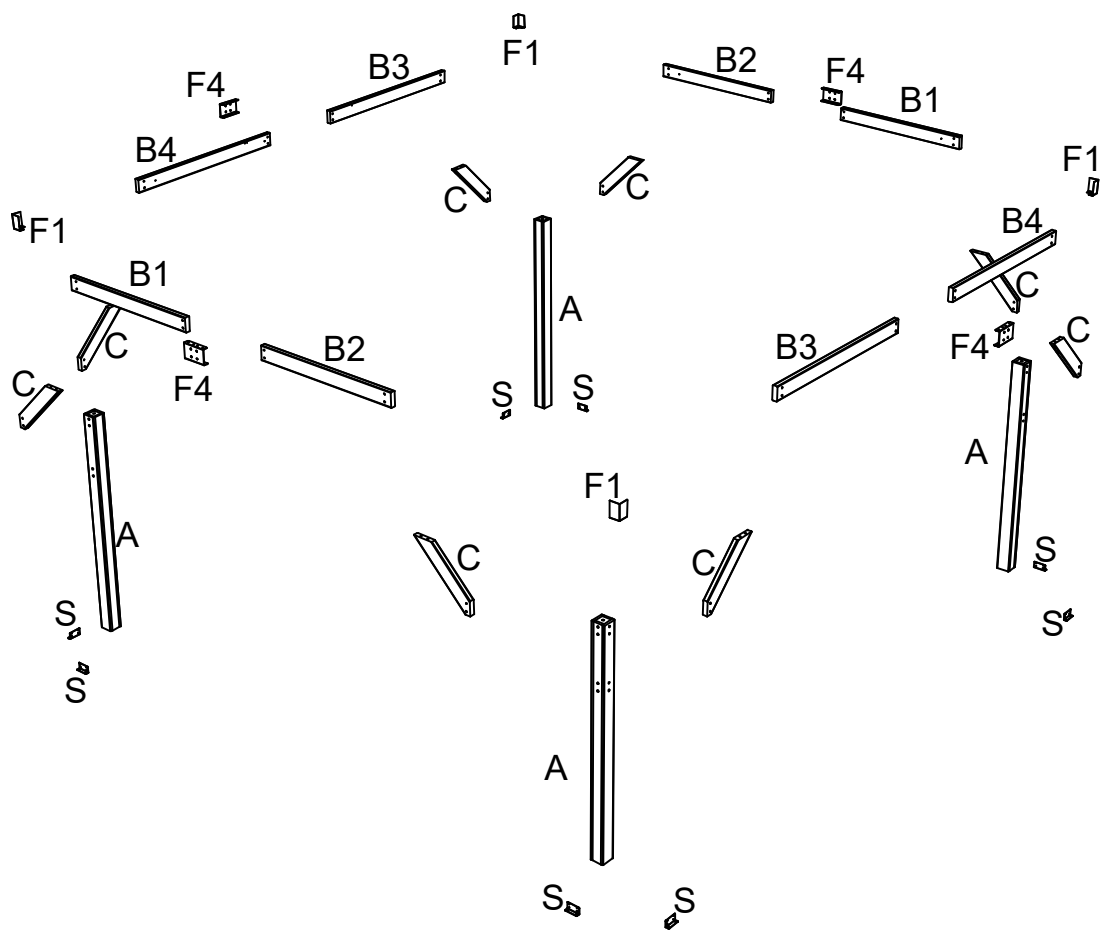

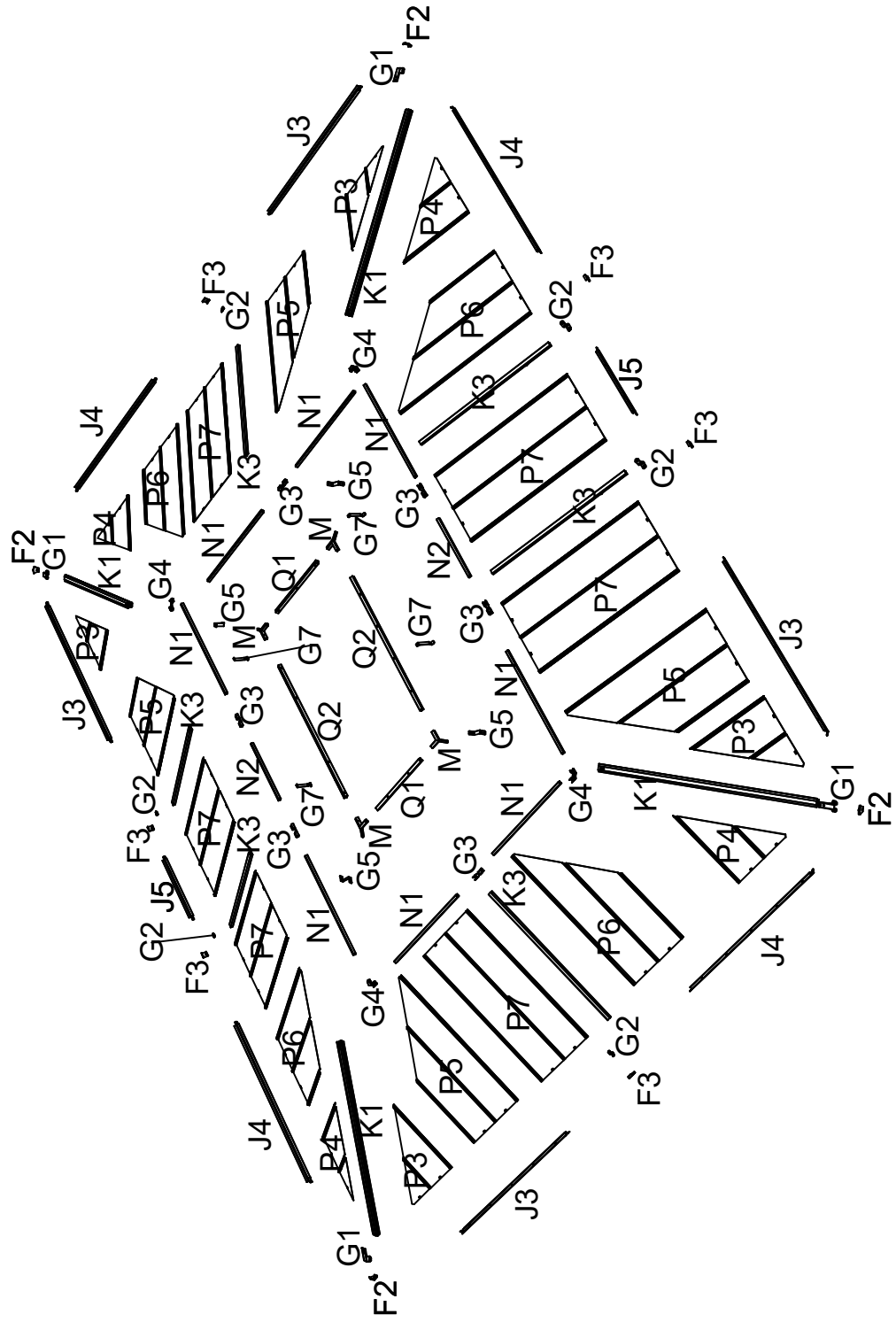

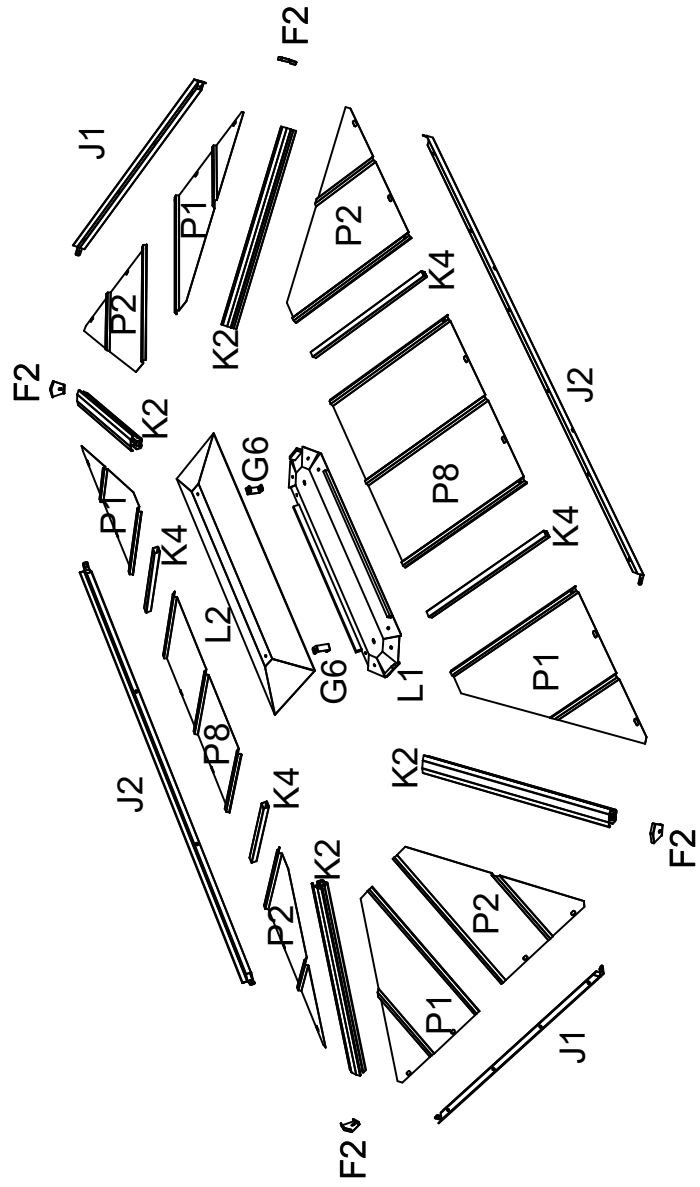



1

B1		2
B2		2
B3		2
B4		2
F4		4

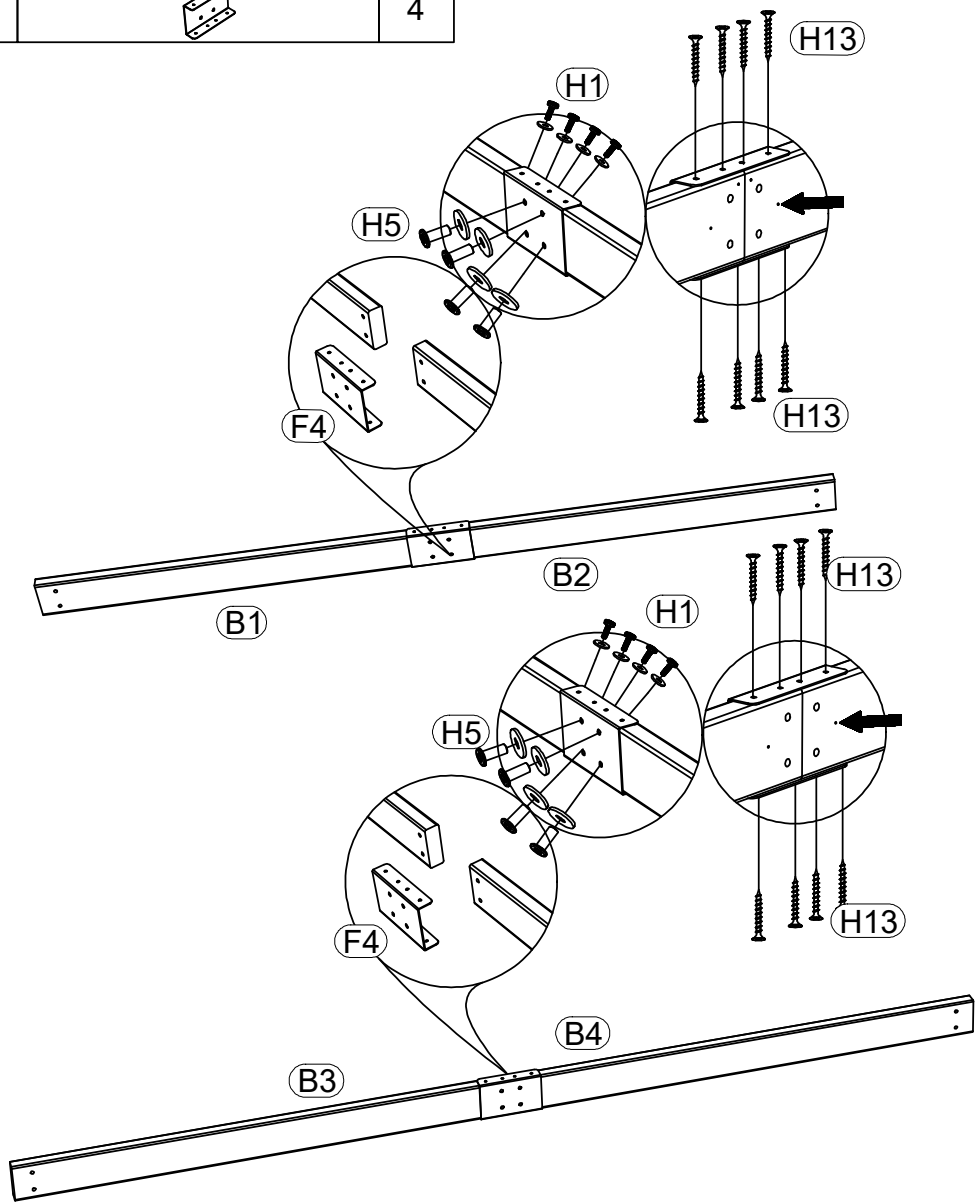
H1		M6X15	16
H5		M6X40	16
H9		M8	32
H13		M4X40	32





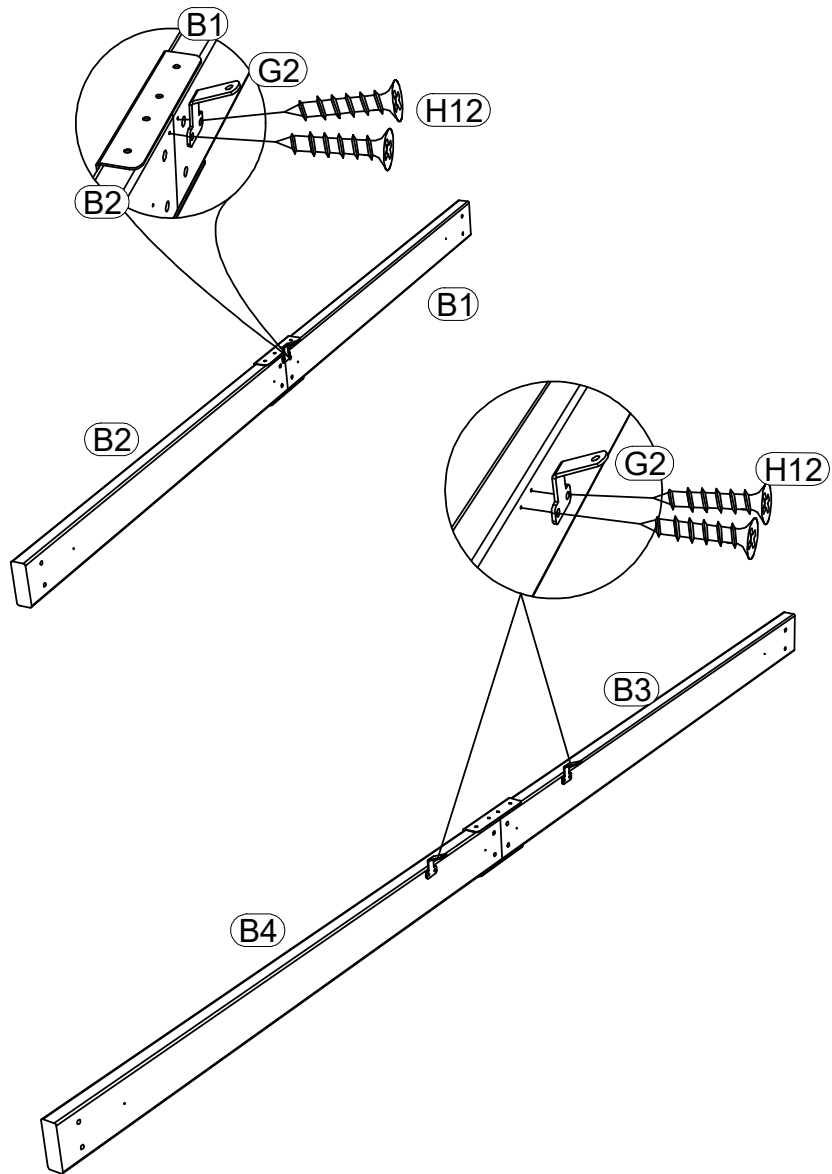

2

G2		6	H12		M4X25	12
----	---	---	-----	--	-------	----

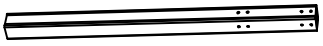

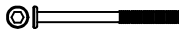

3

A		4
C		4

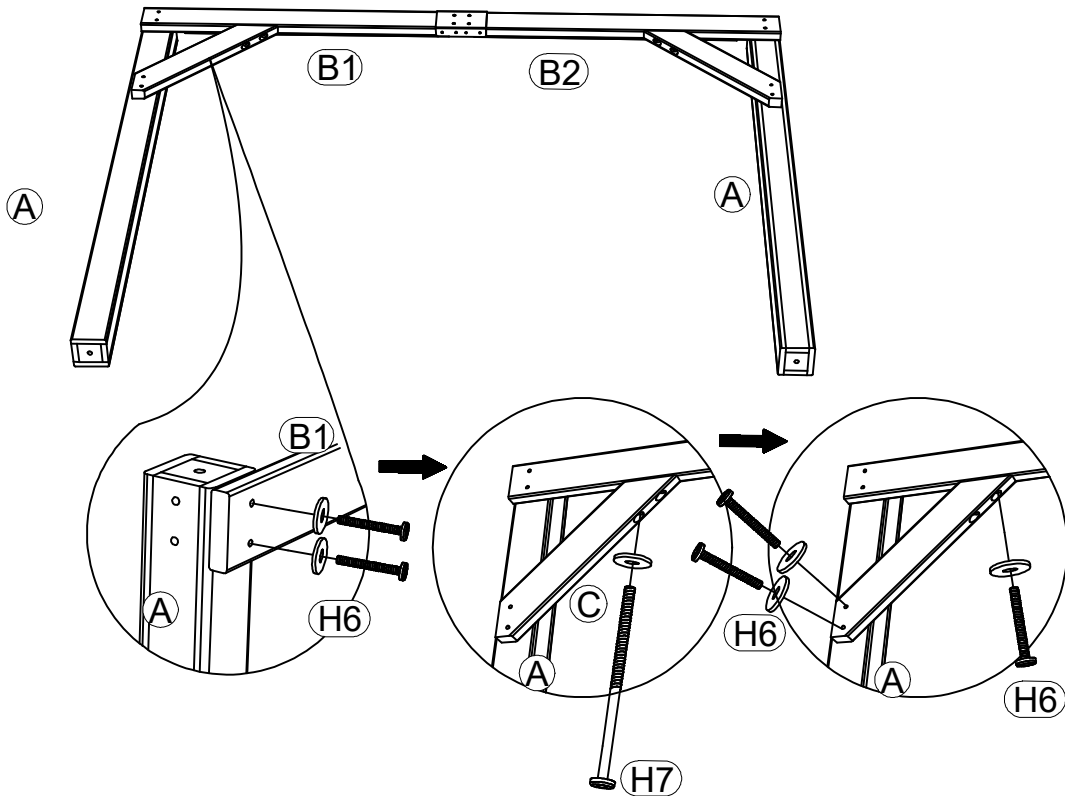
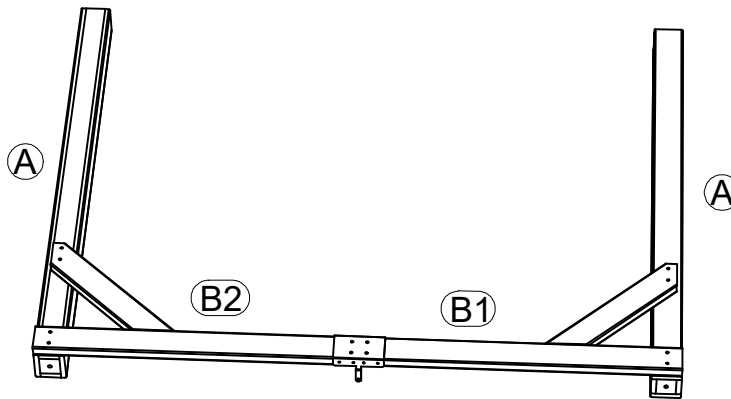
H6		M8X60	20
H7		M8X120	4
H9		M8	24



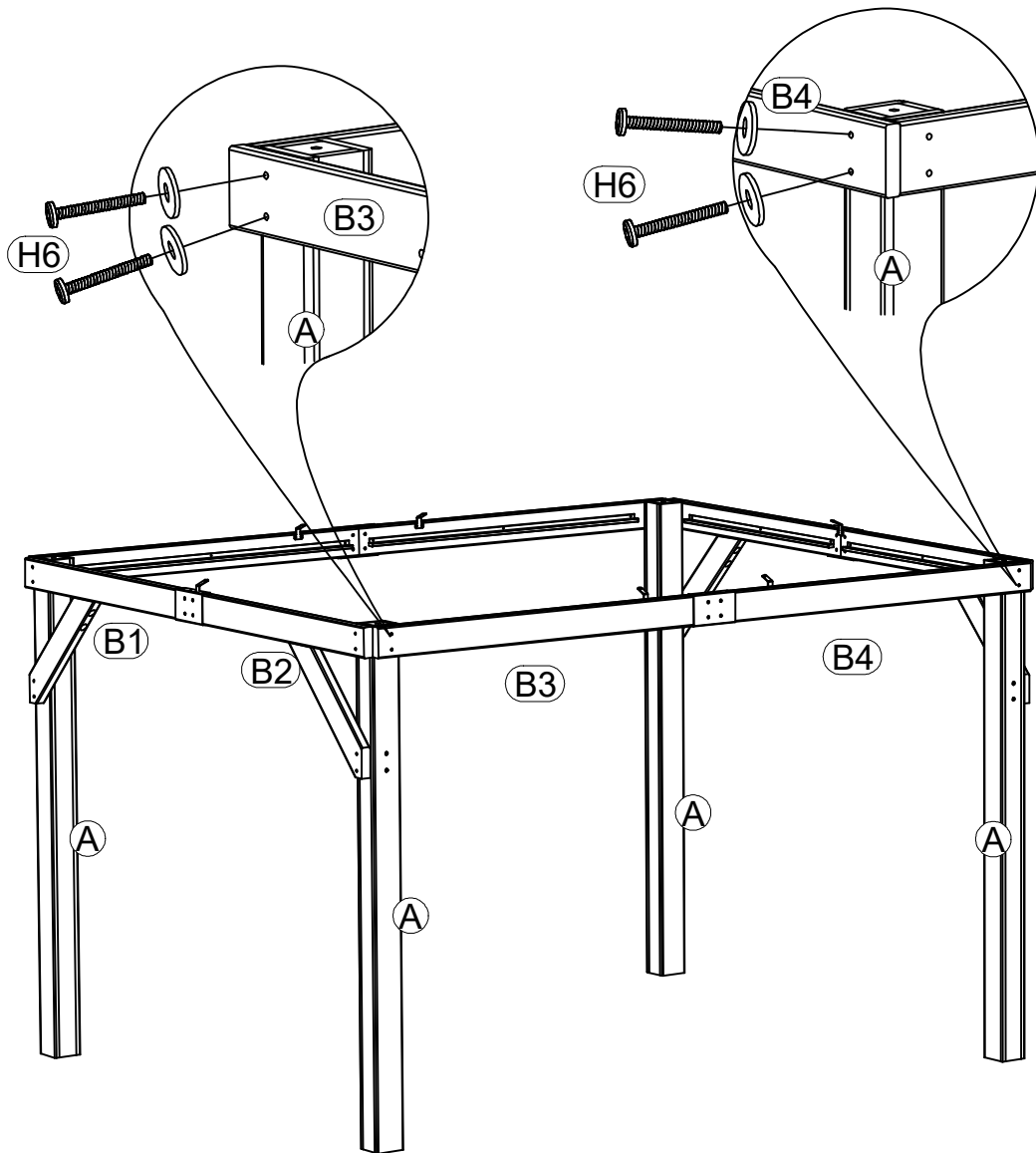

4

H6		M8X60	8
H9		M8	8





5

C		4
H6	 M8X60	12

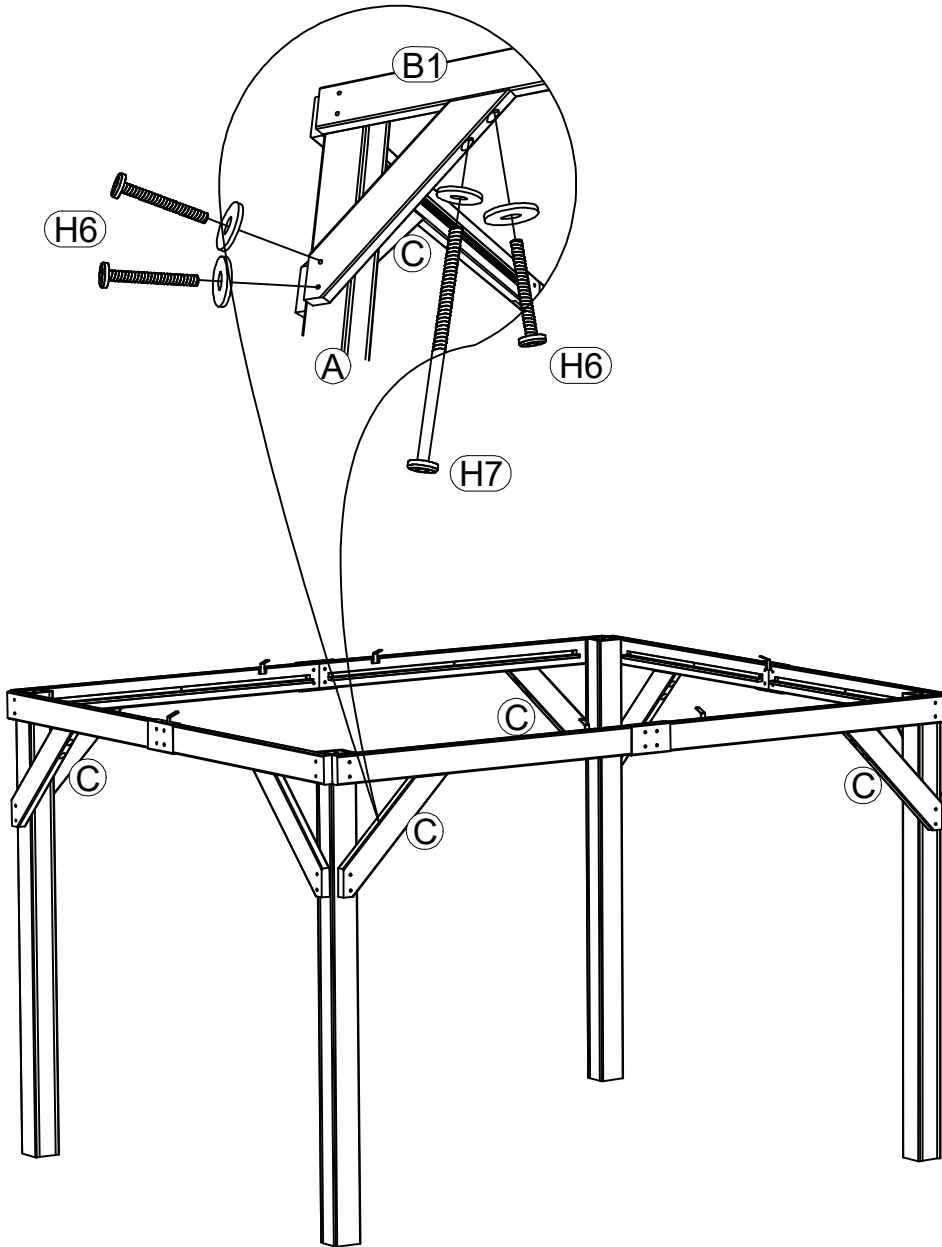
H7		M8X120	4
H9		M8	16





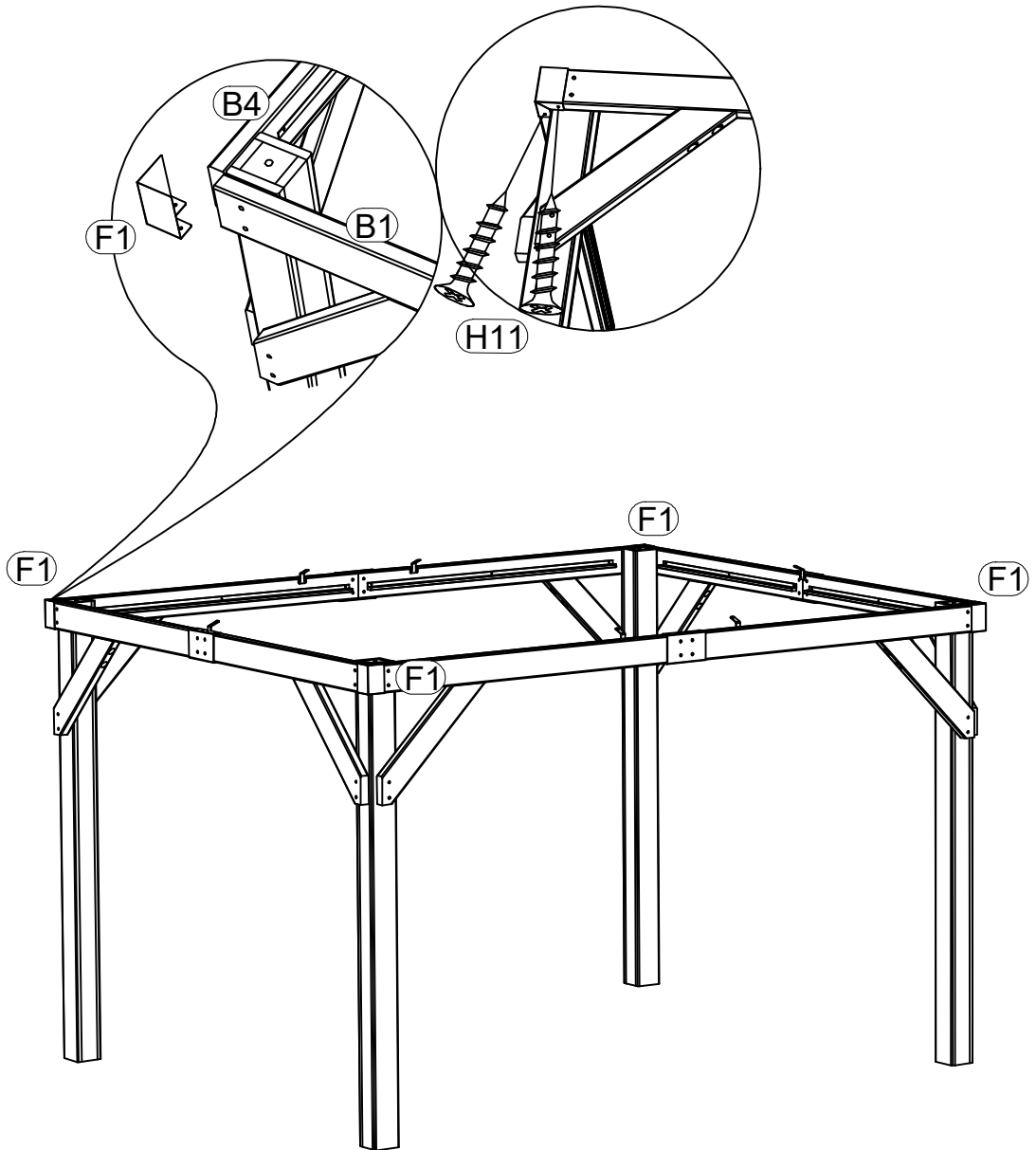

6

F1			4
H11		M4X16	8



7

K1		4
G1		4
G5		4

H1		M6X15	16
H8		M6	16

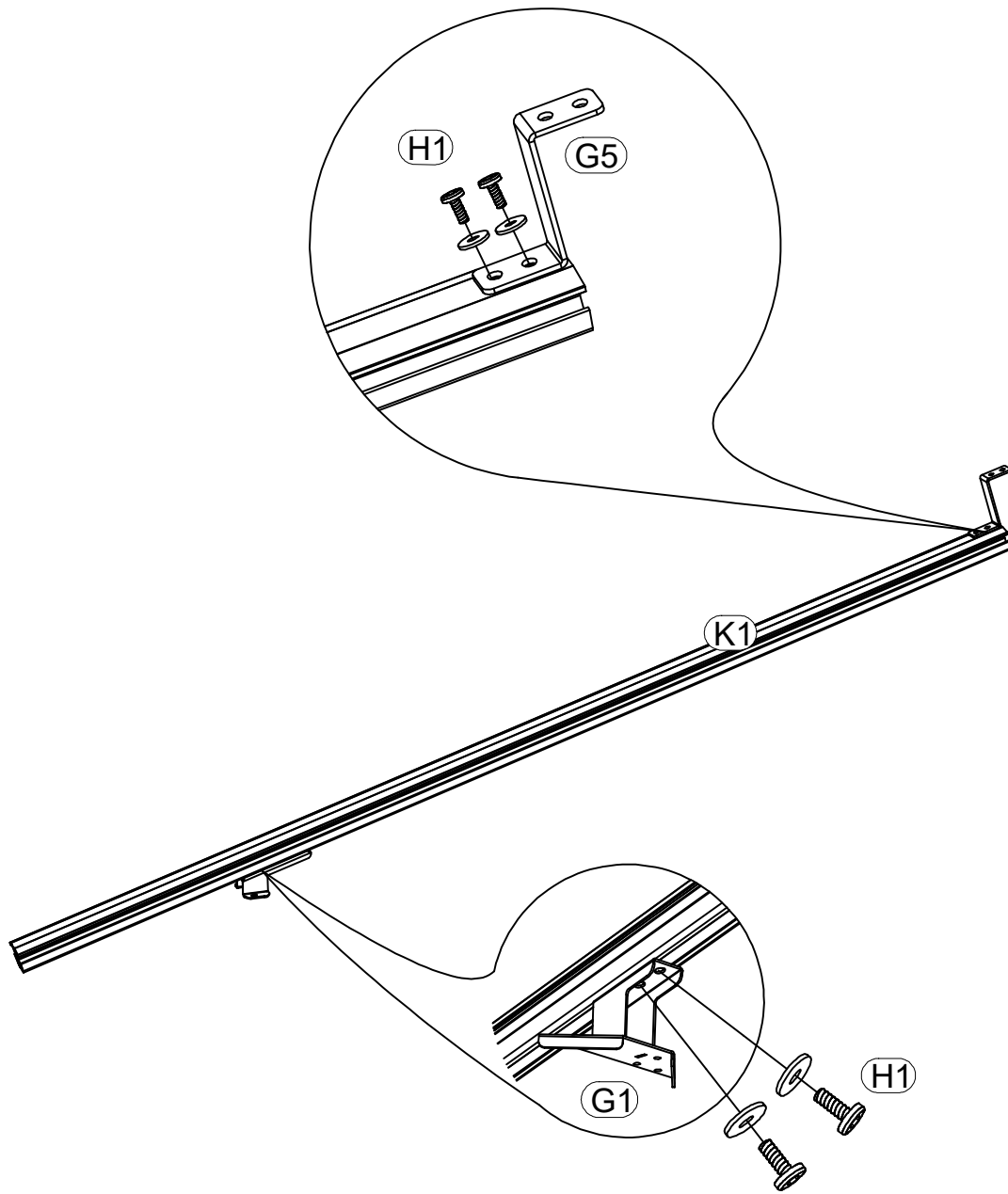



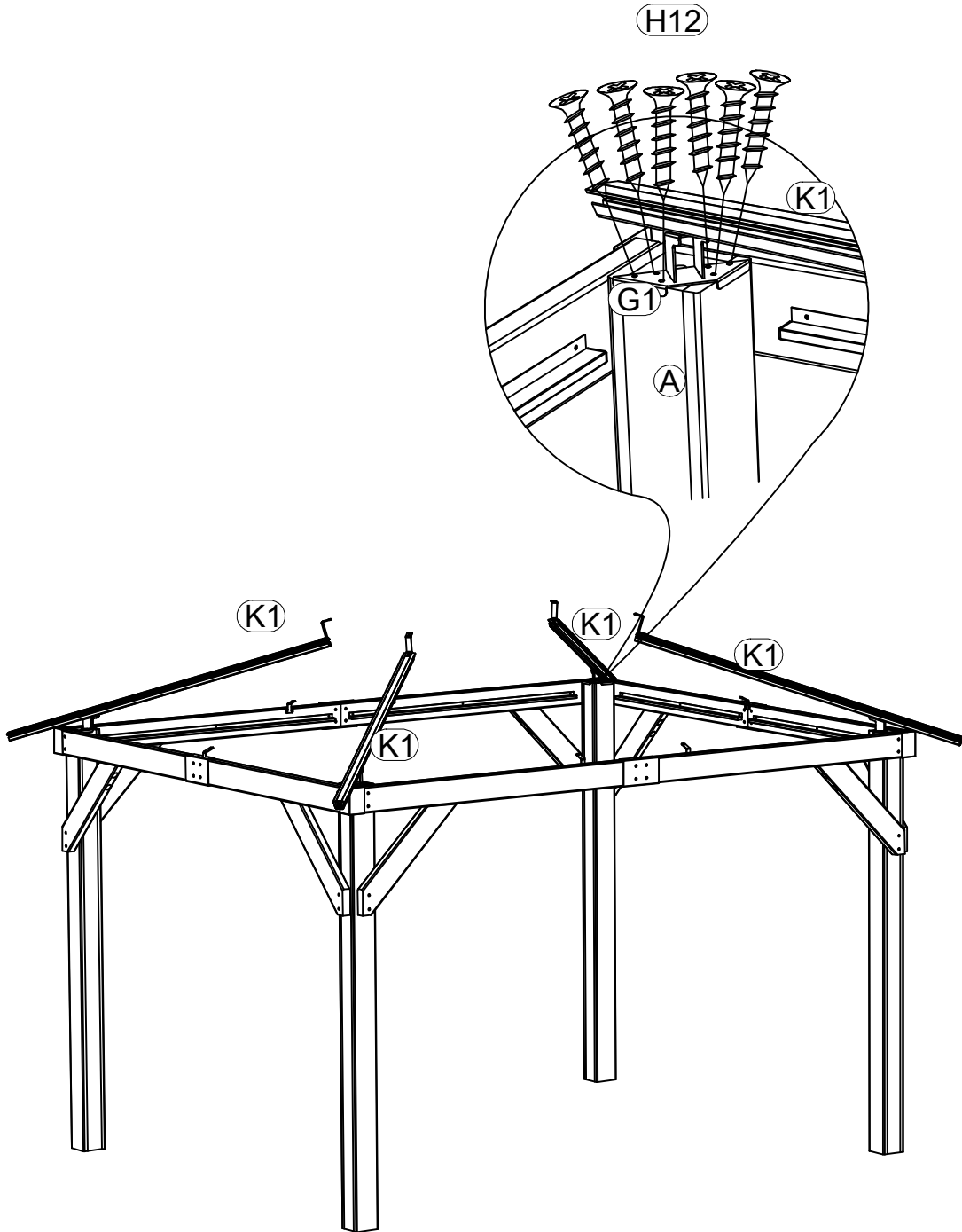

8

H12		M4X25	24
-----	---	-------	----



9

Q1		2
Q2		2
M		4

H1		M6X15	8
H8		M6	8

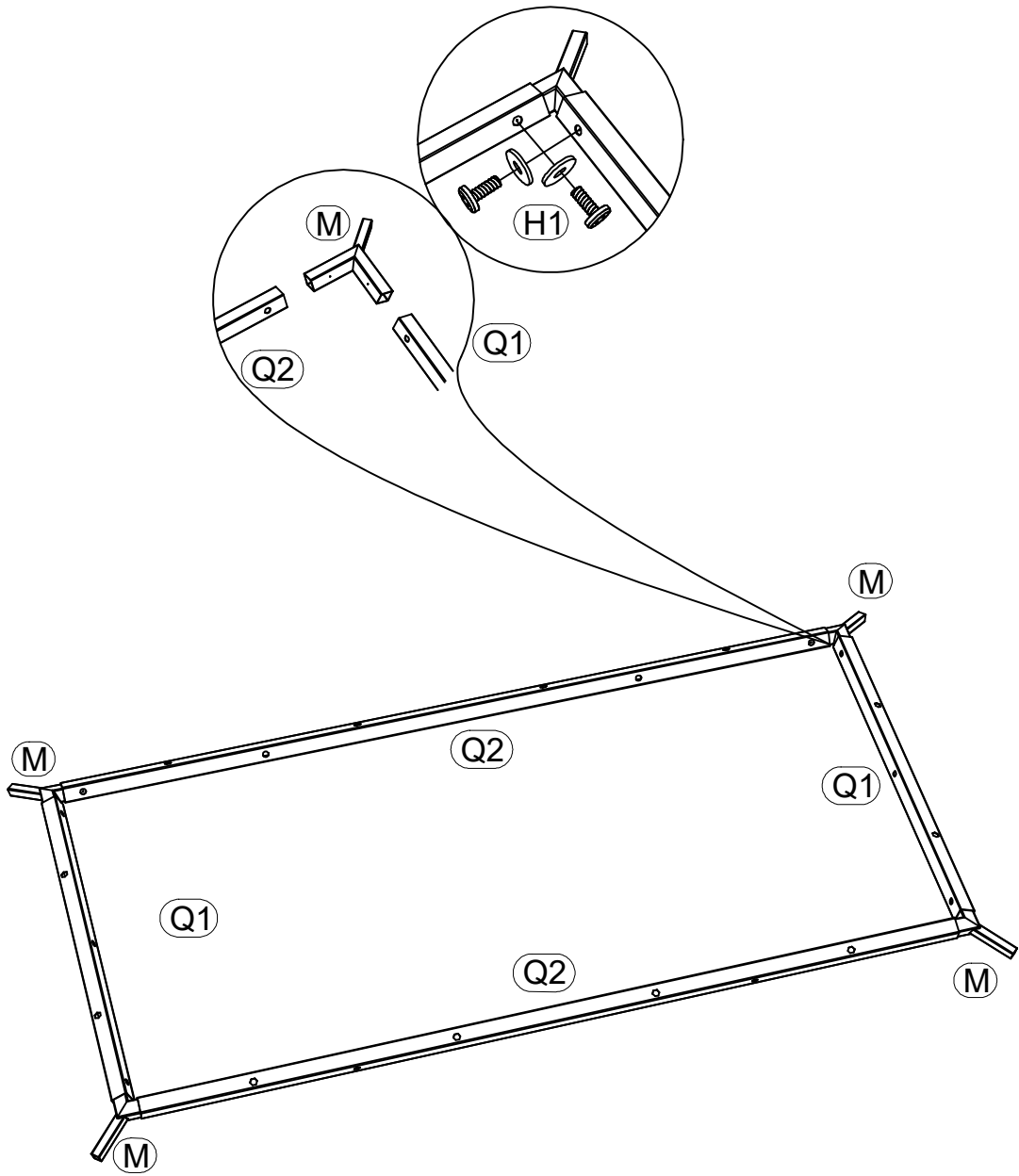



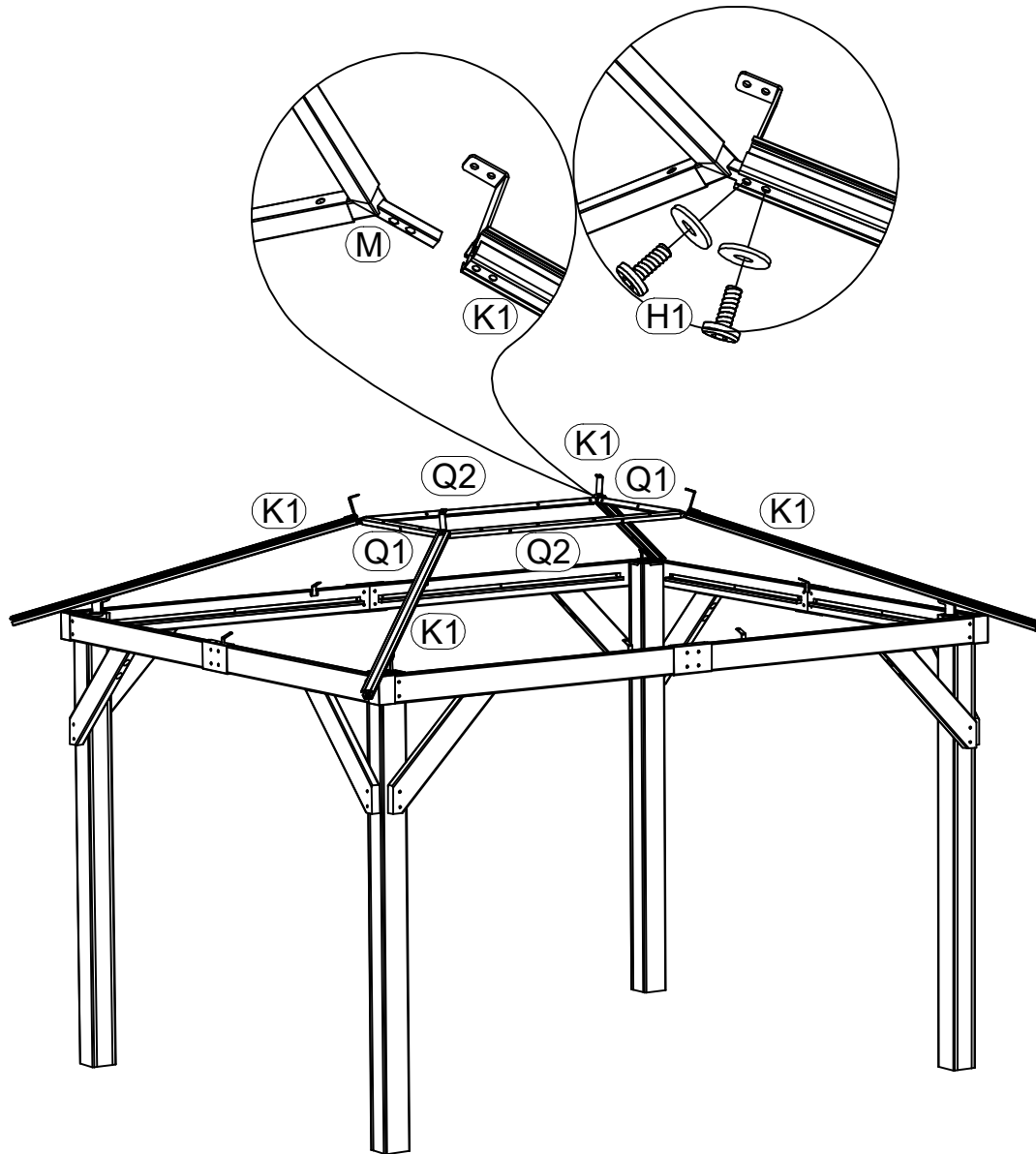

10

H1		M6X15	8
H8		M6	8





11

K3		6
G7		4

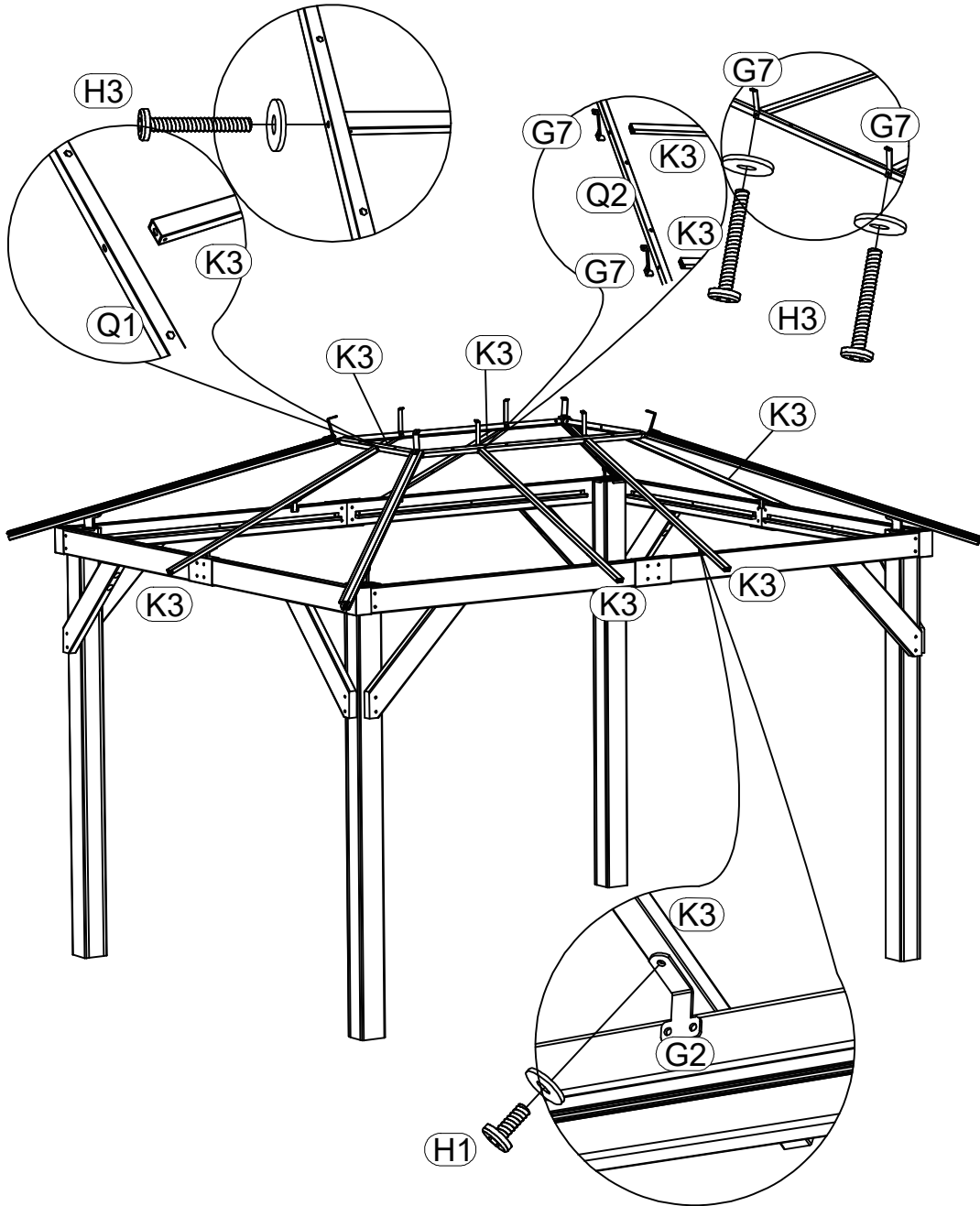
H1		M6X15	6
H8		M6	12
H3		M6X40	6



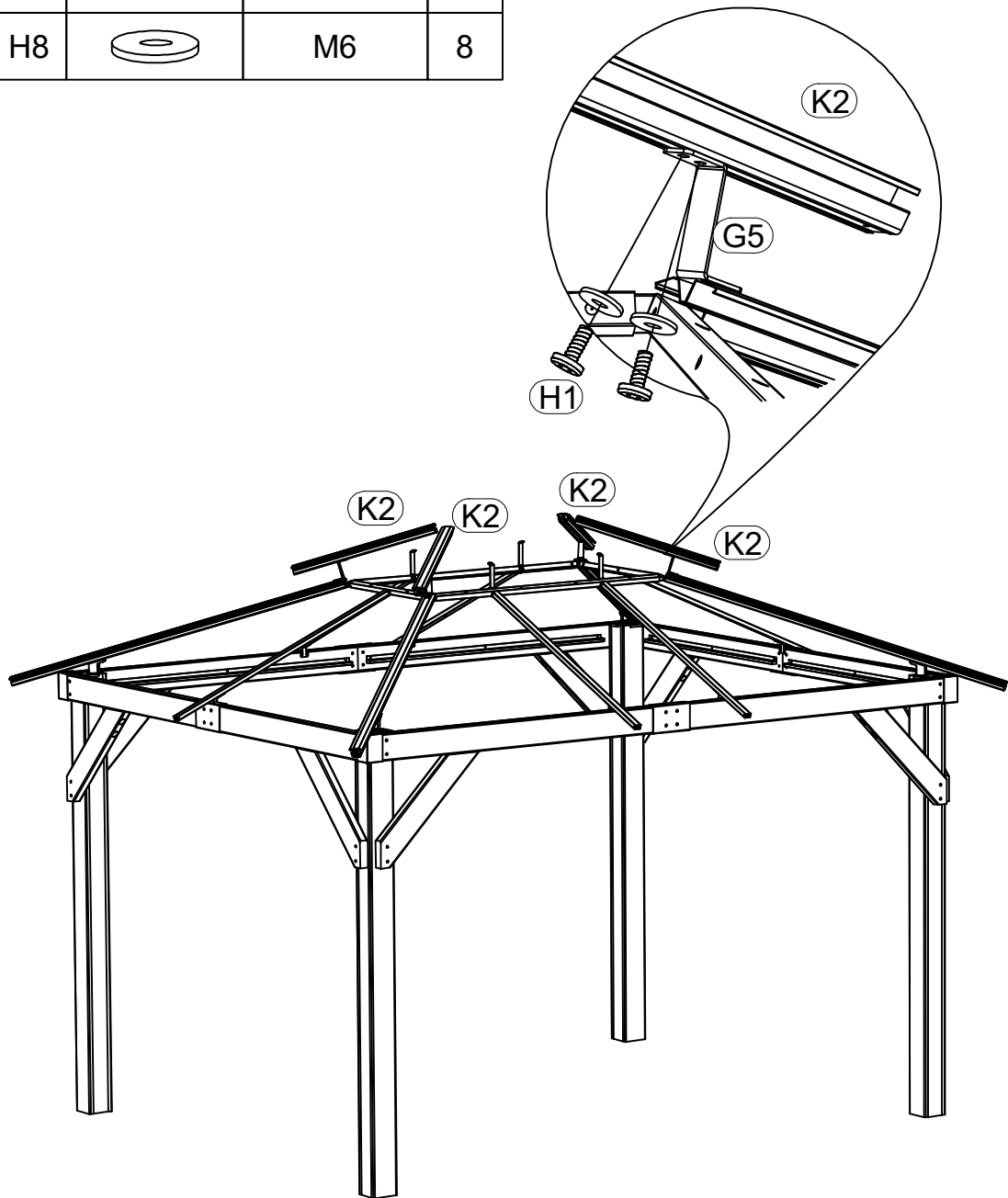

12

K2			4
H1		M6X15	8
H8		M6	8



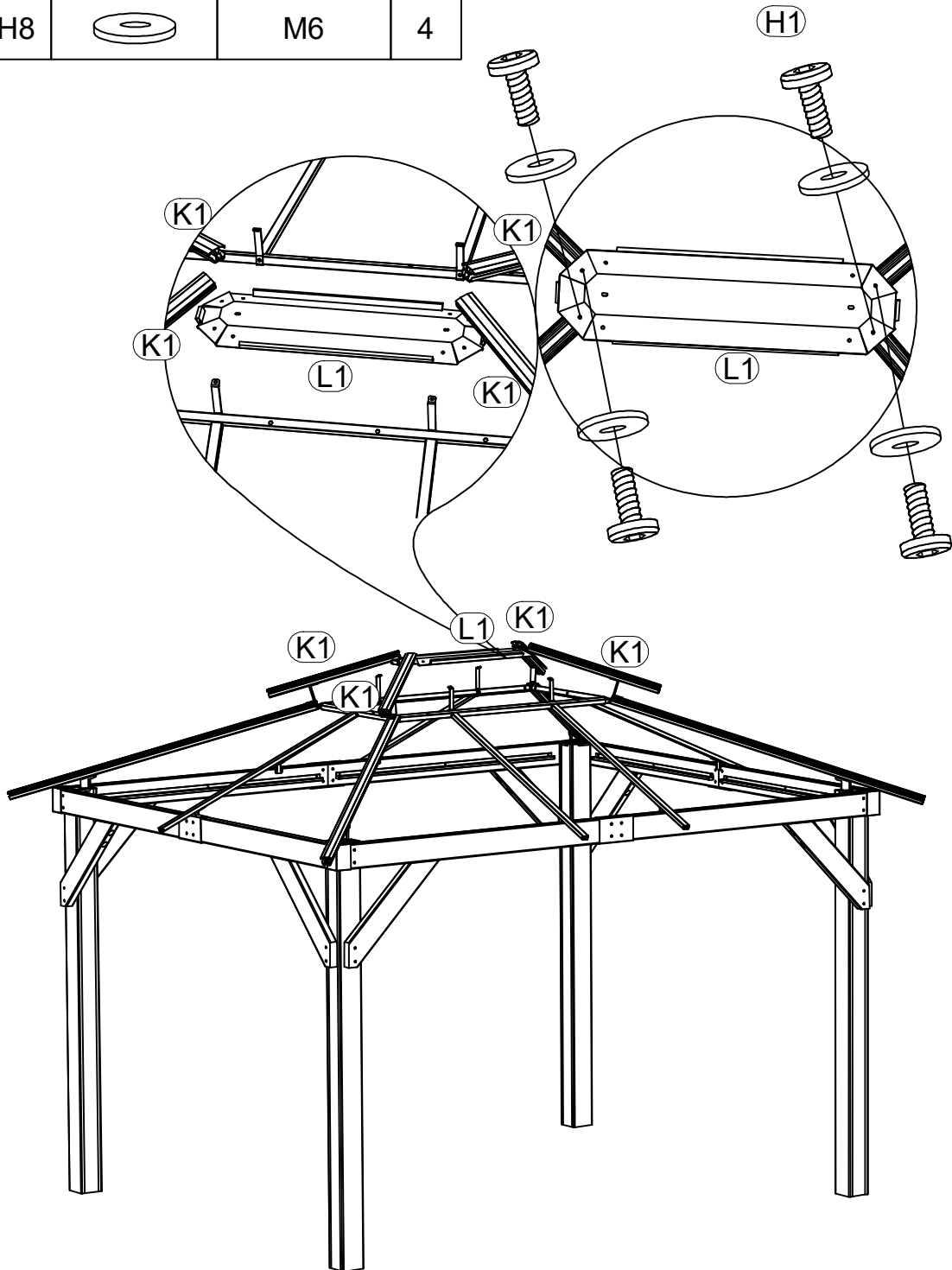

13

L1			1
H1		M6X15	4
H8		M6	4





14

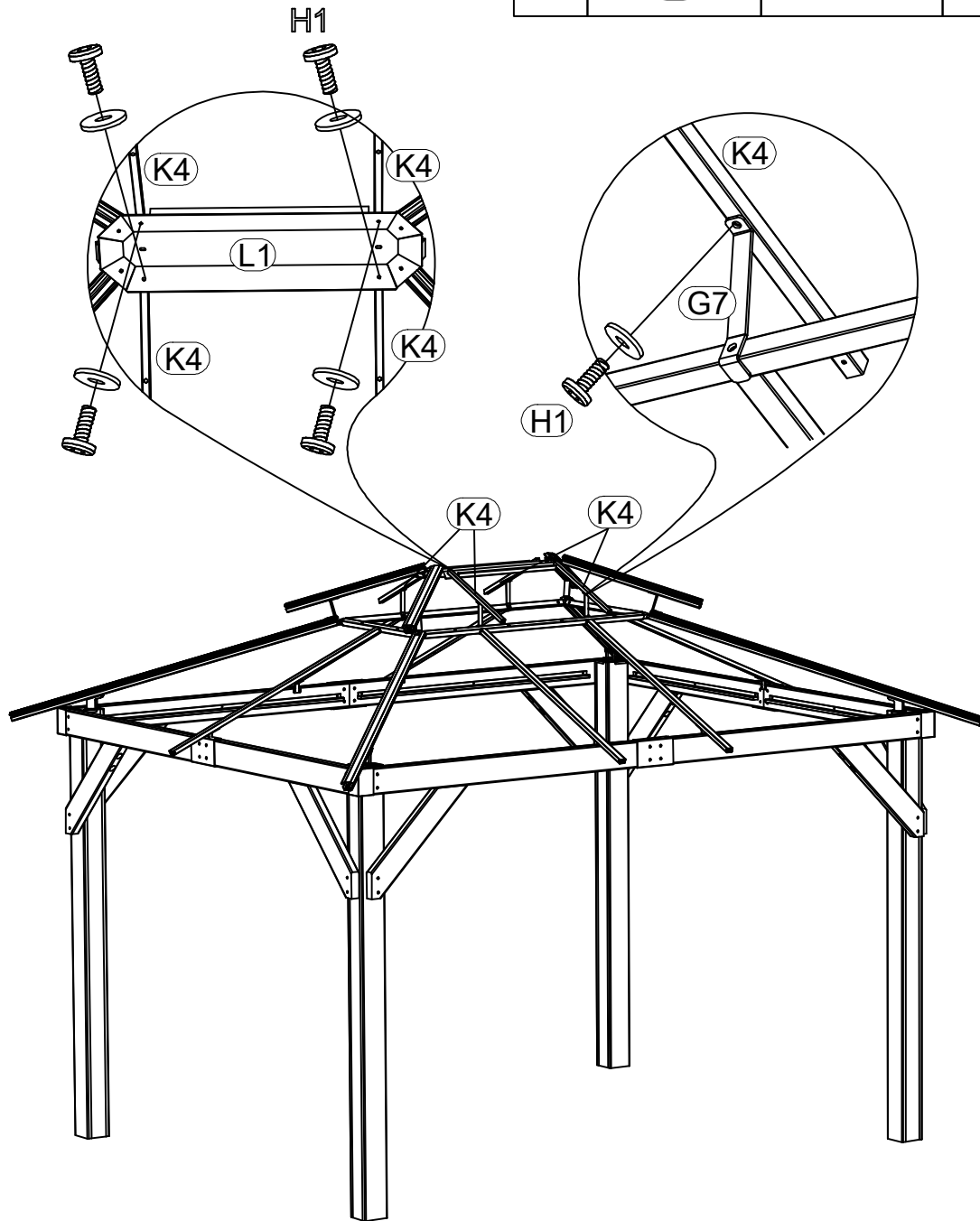

K4		4
----	---	---

H1		M6X15	8
H8		M6	8





15

J1		2
J2		2
F2		4

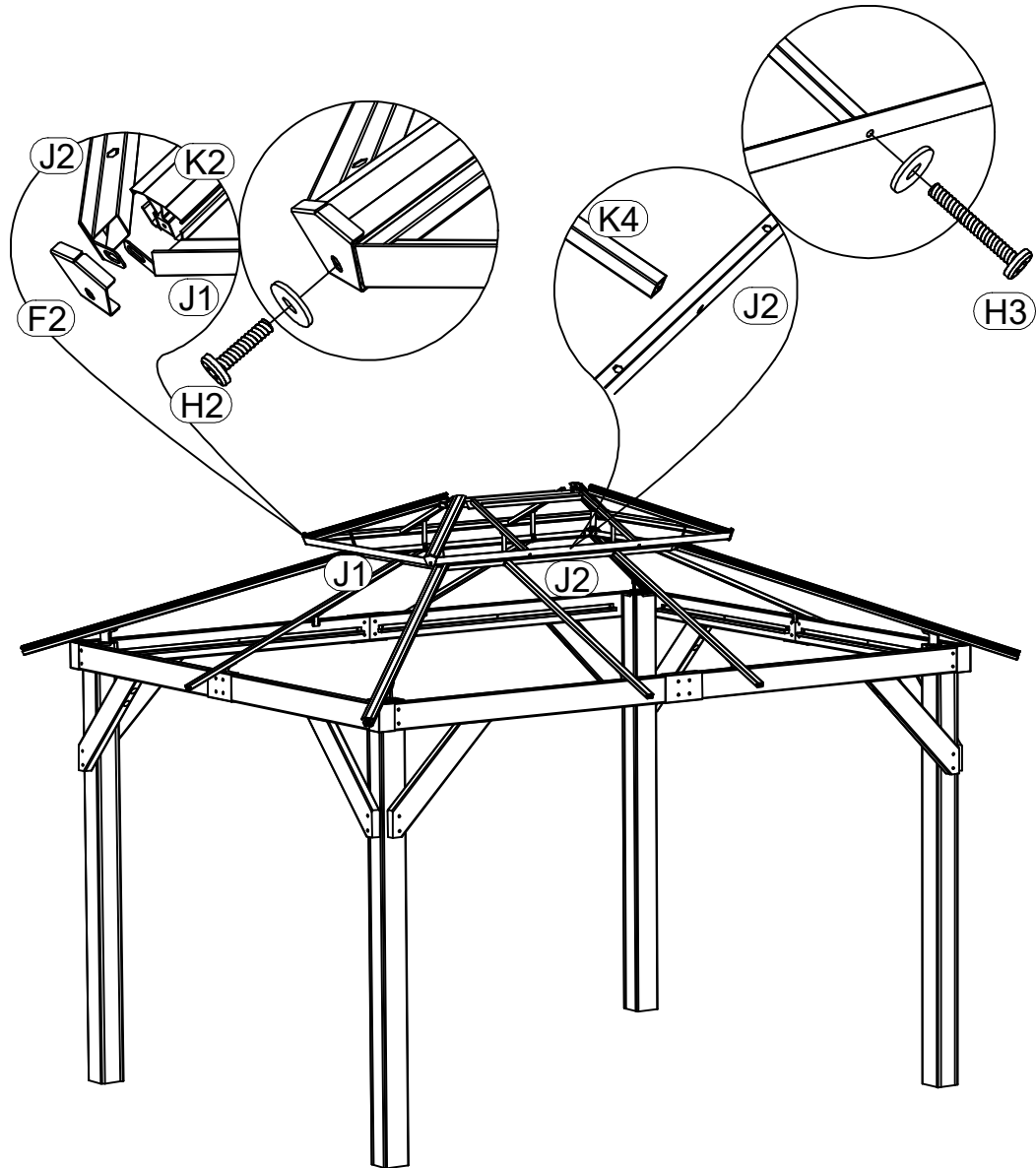
H2		M6X25	4
H8		M6	8
H3		M6X40	4



16

P1		4
P8		2

P2		4
----	---	---

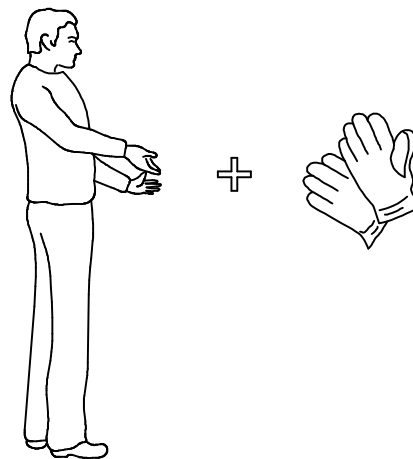
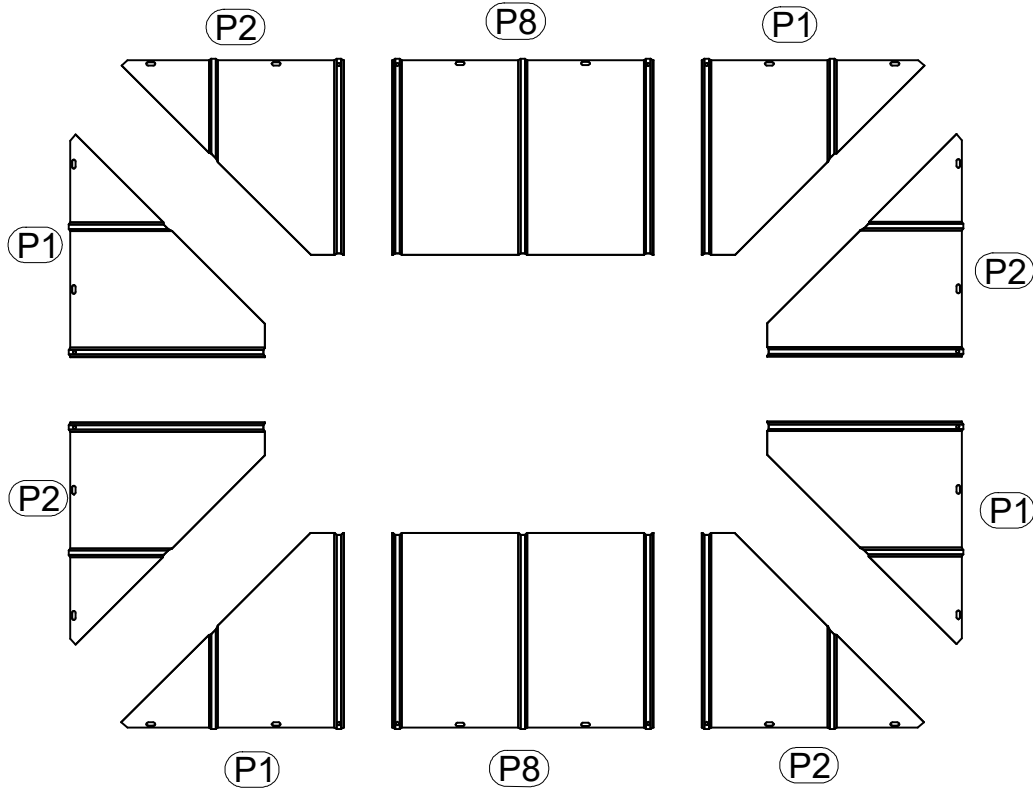



When instructions for installing the roof panels, Please wear gloves!

17

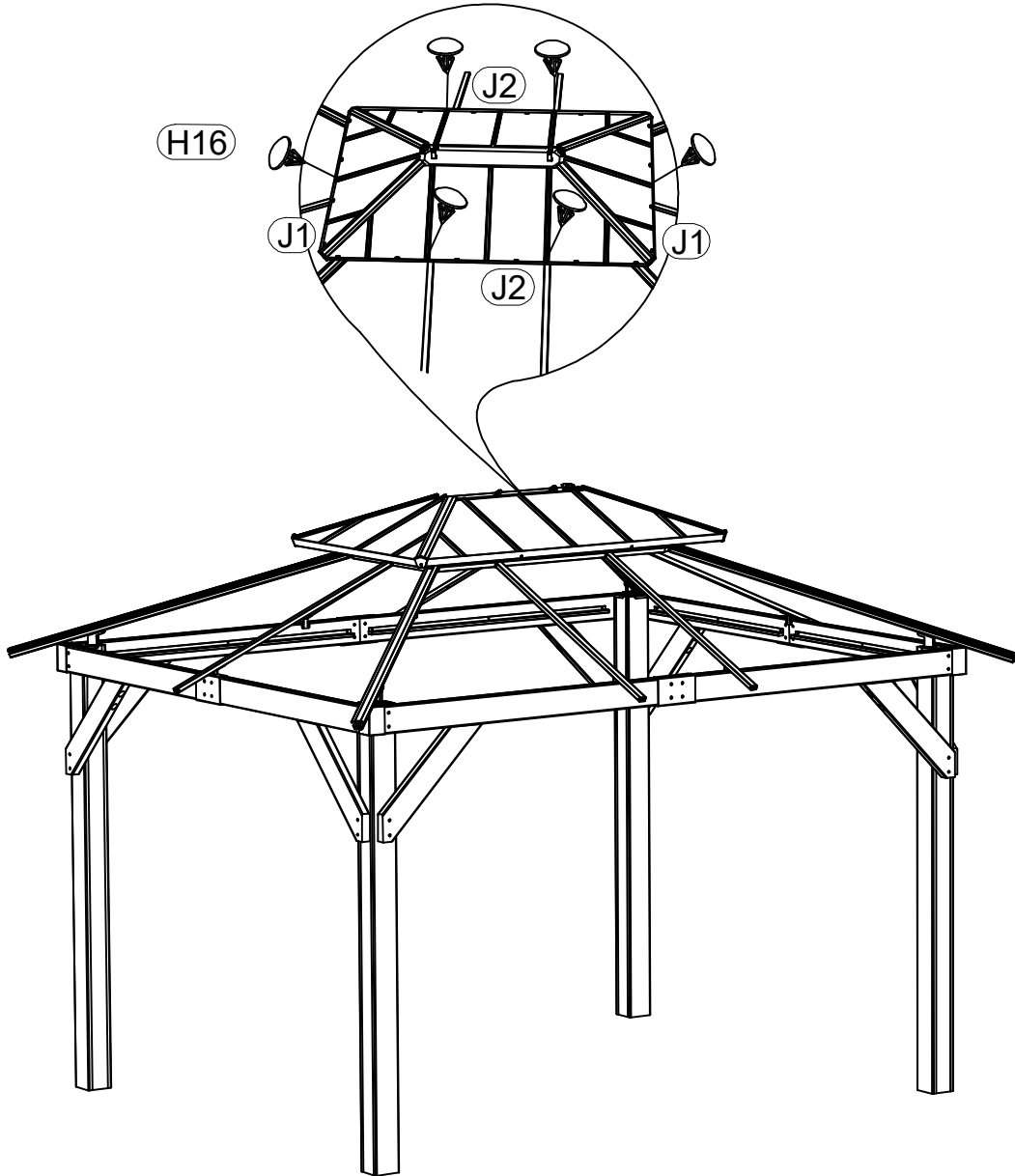
H16			6
-----	---	--	---





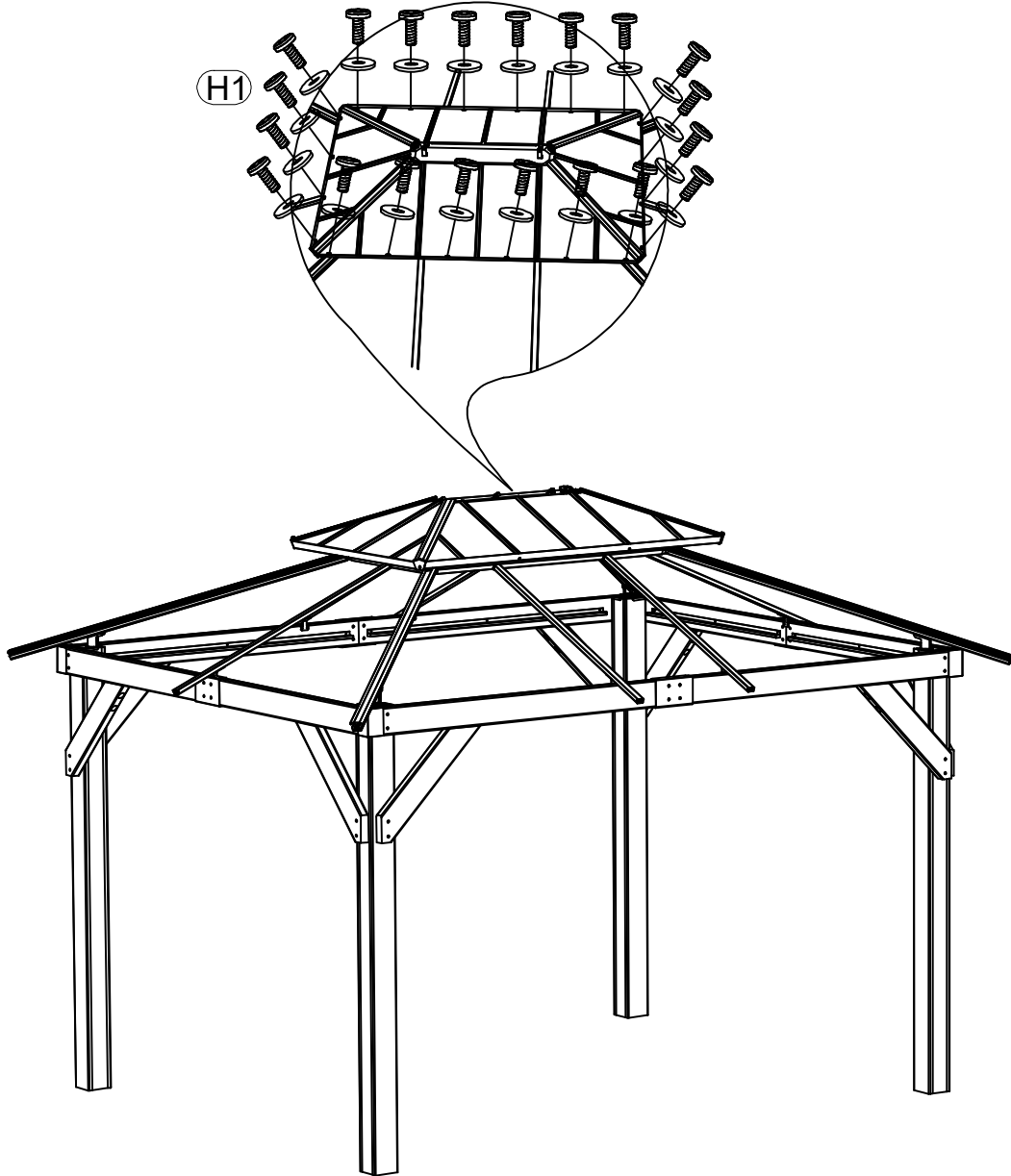

18

H1		M6X15	20
H8		M6	20

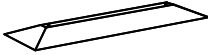

19

G6		2
L2		1

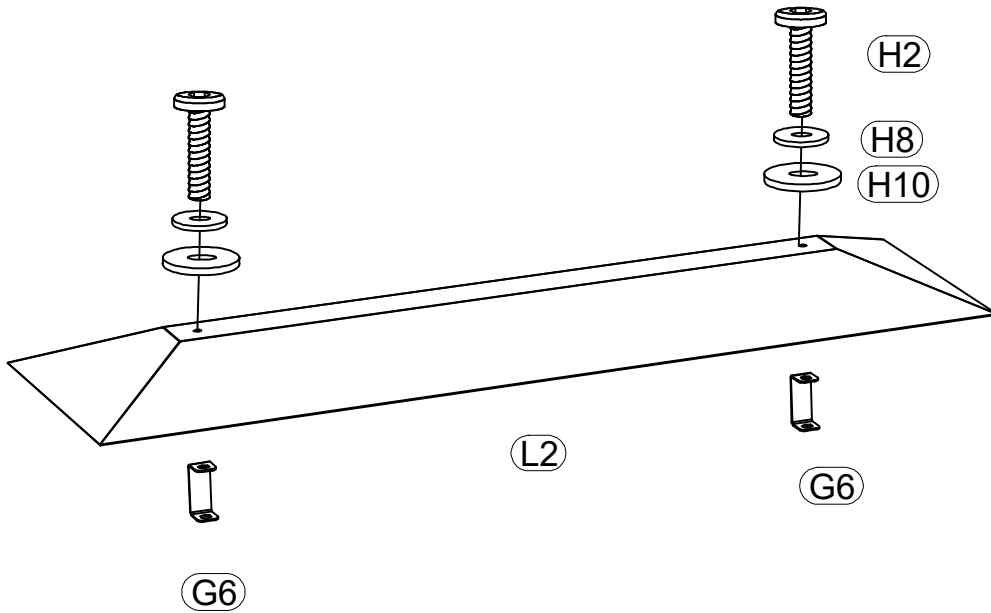

H2		M6X25	2
H10		RUBBER	2
H8		M6	2

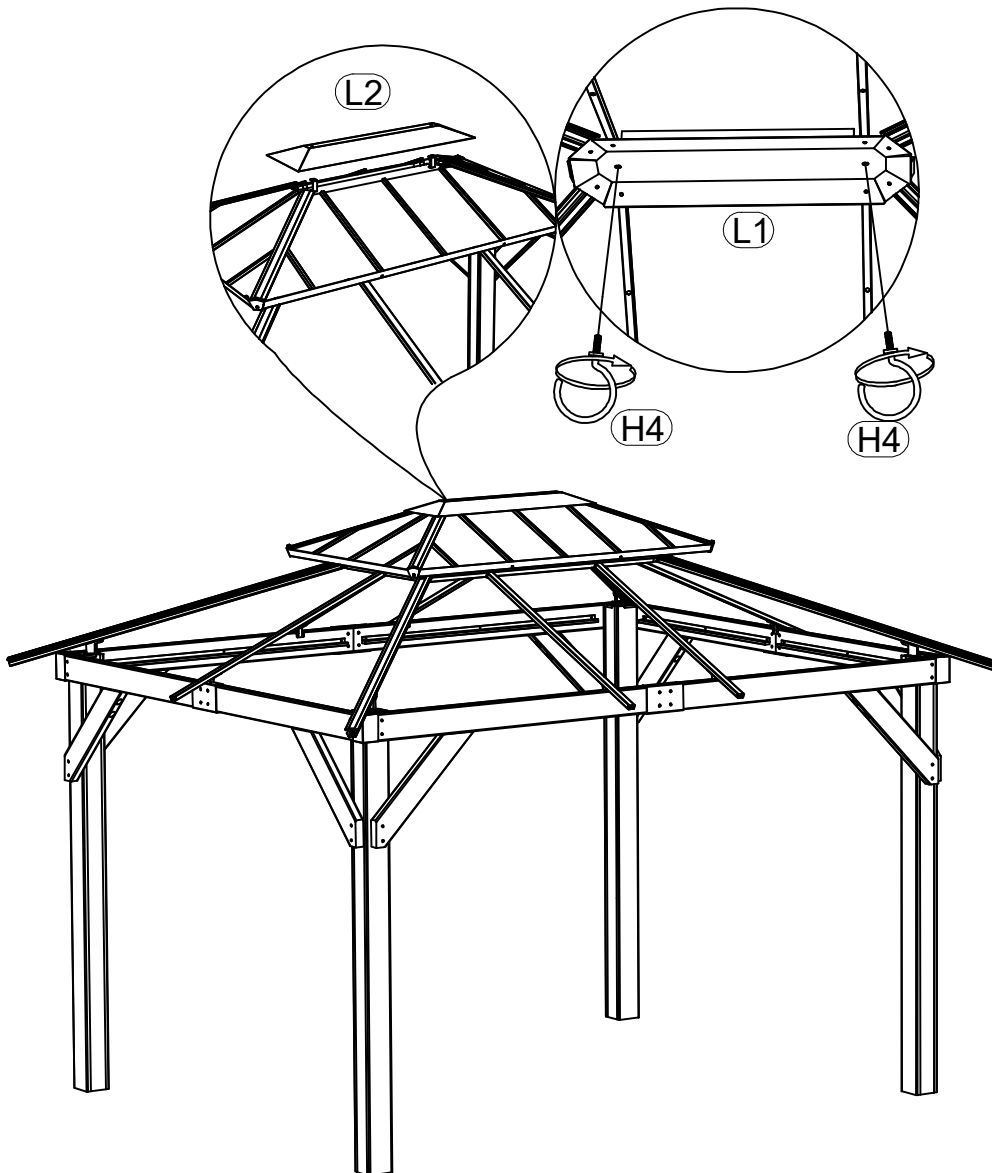

H4		2
----	---	---





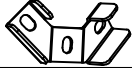

21

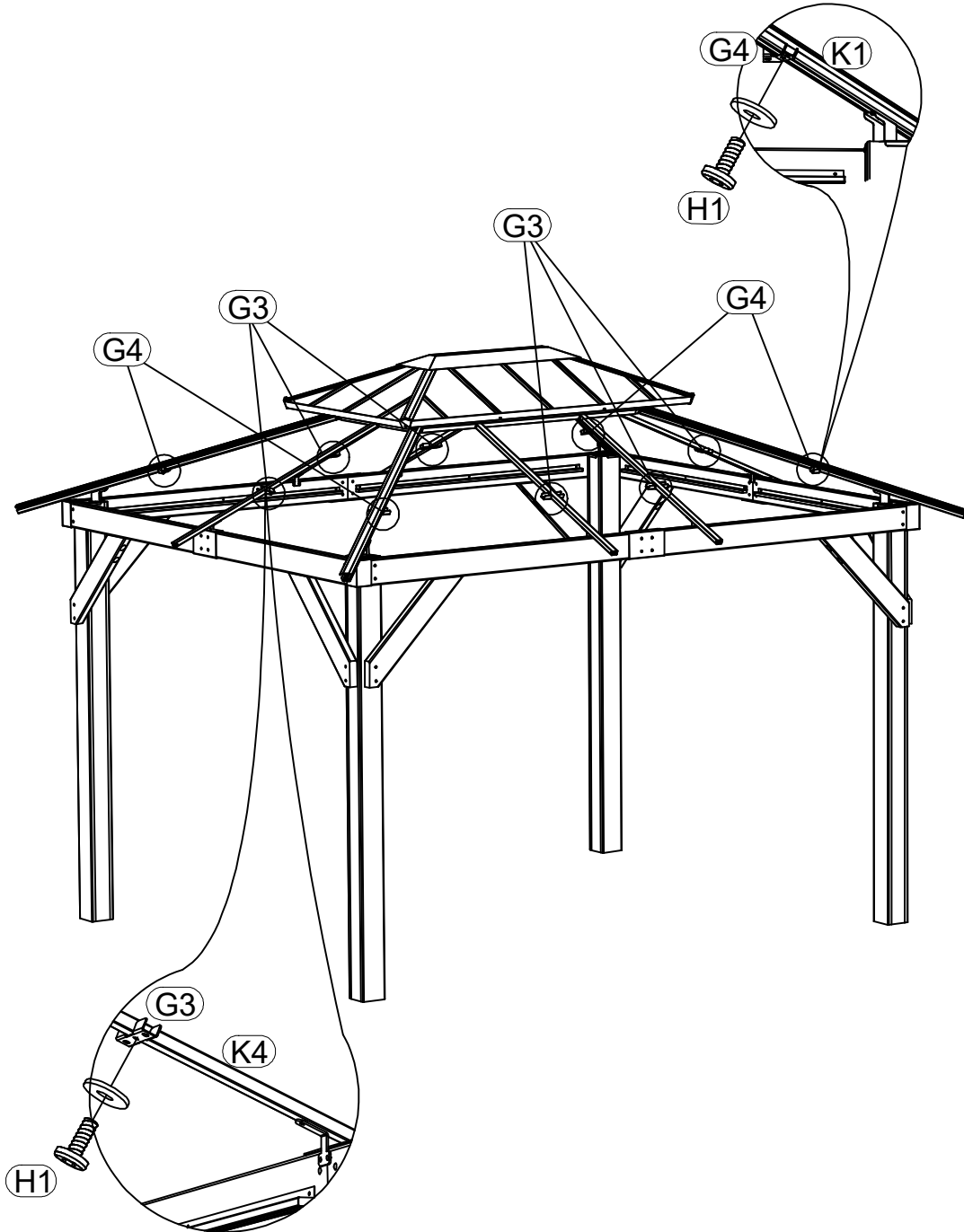
H1		M6X15	10
H8		M6	10

G3		6
G4		4







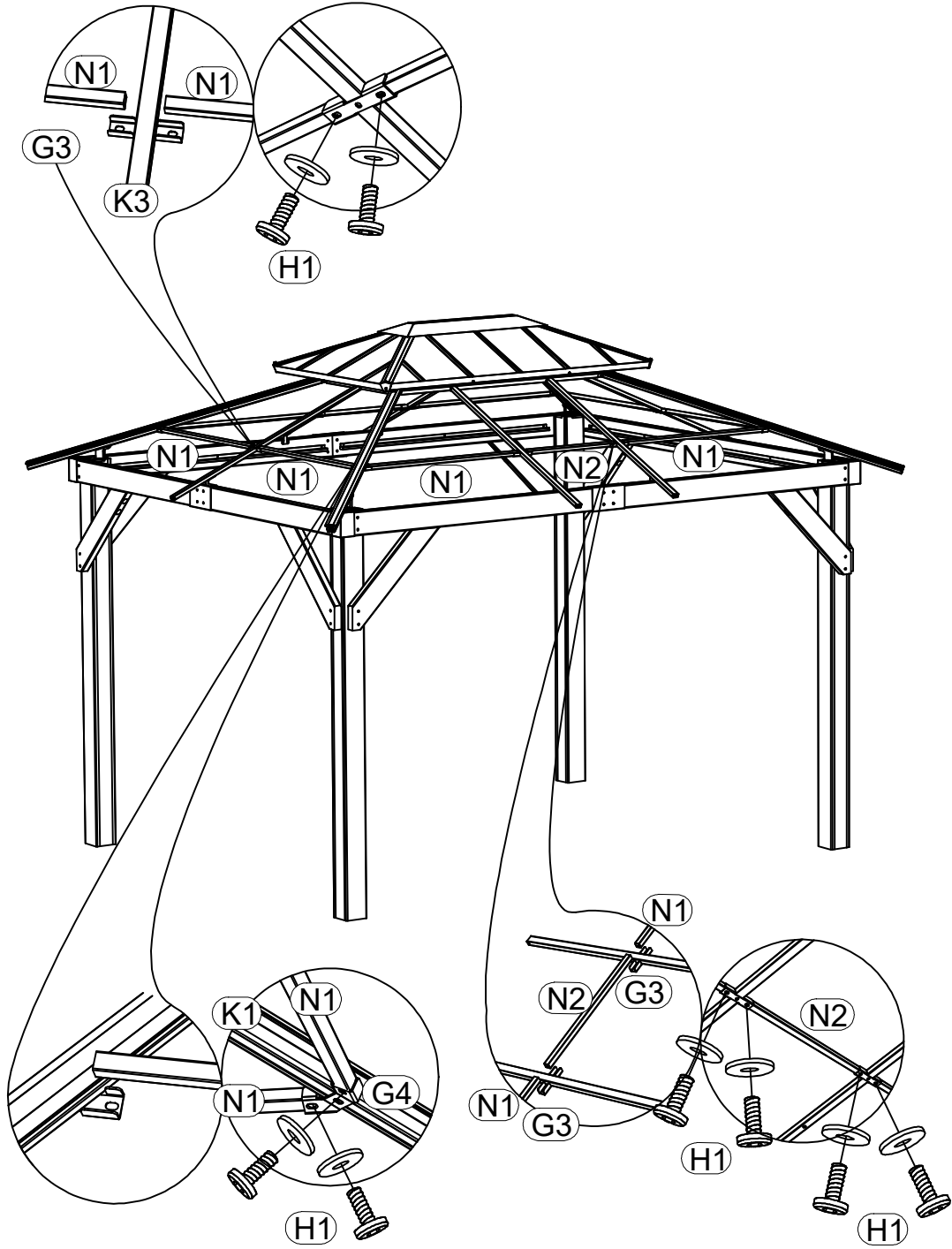

N1		8
N2		2

H1		M6X15	20
H8		M6	20





23

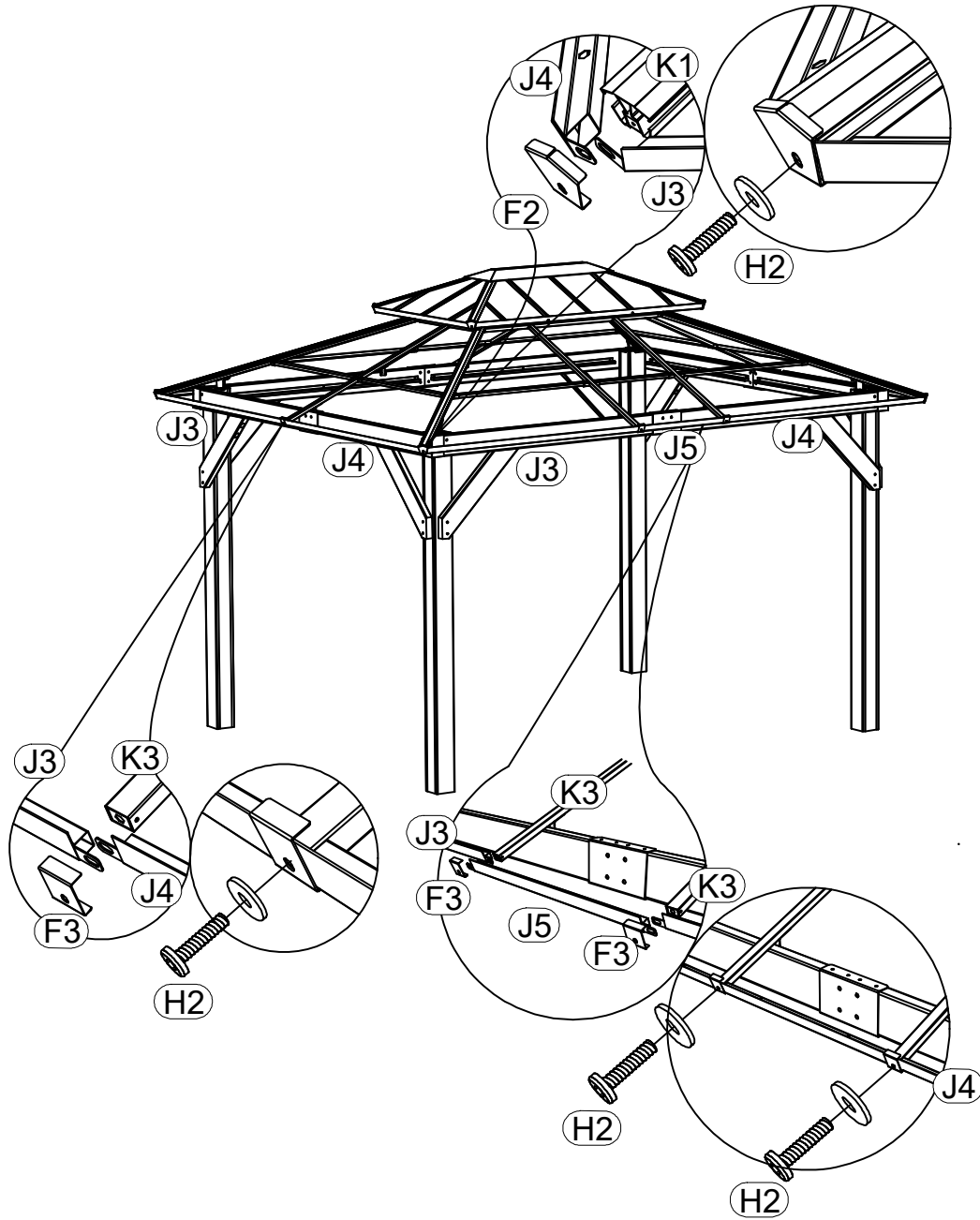

J3		4
J4		4
J5		2

H2		M6X25	10
H8		M6	10
F2			4
F3			6

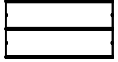

24

P3		4
P5		4
P7		6

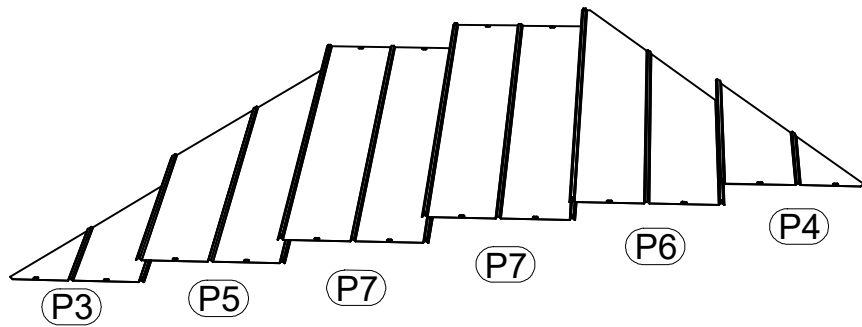
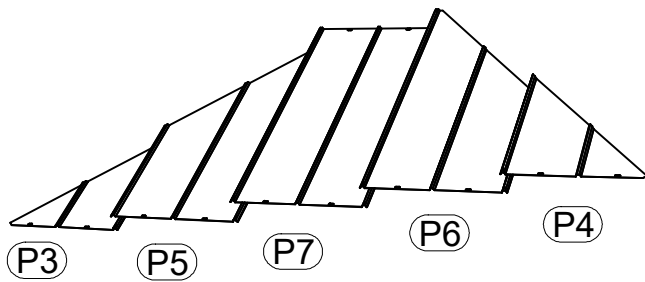
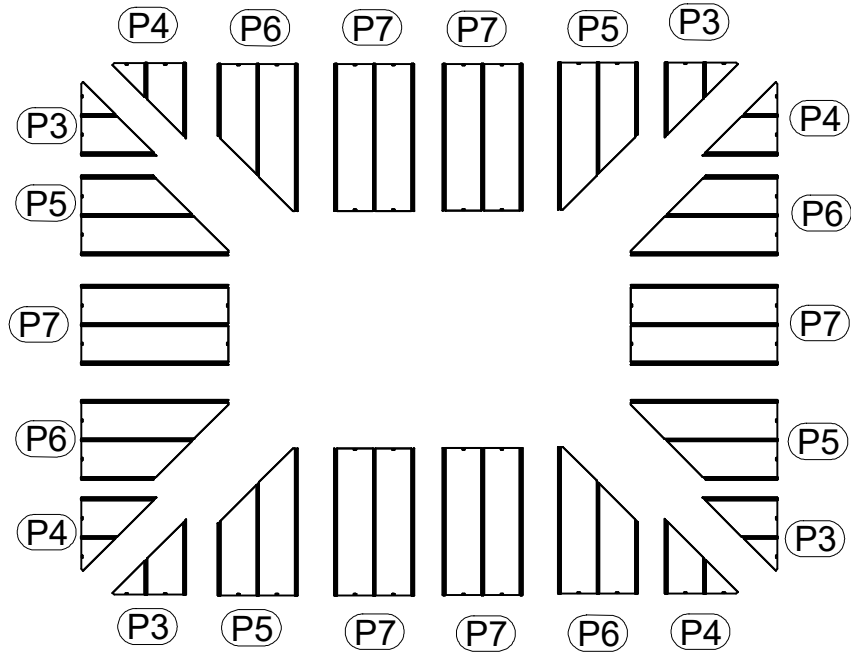

P4		4
P6		4



25

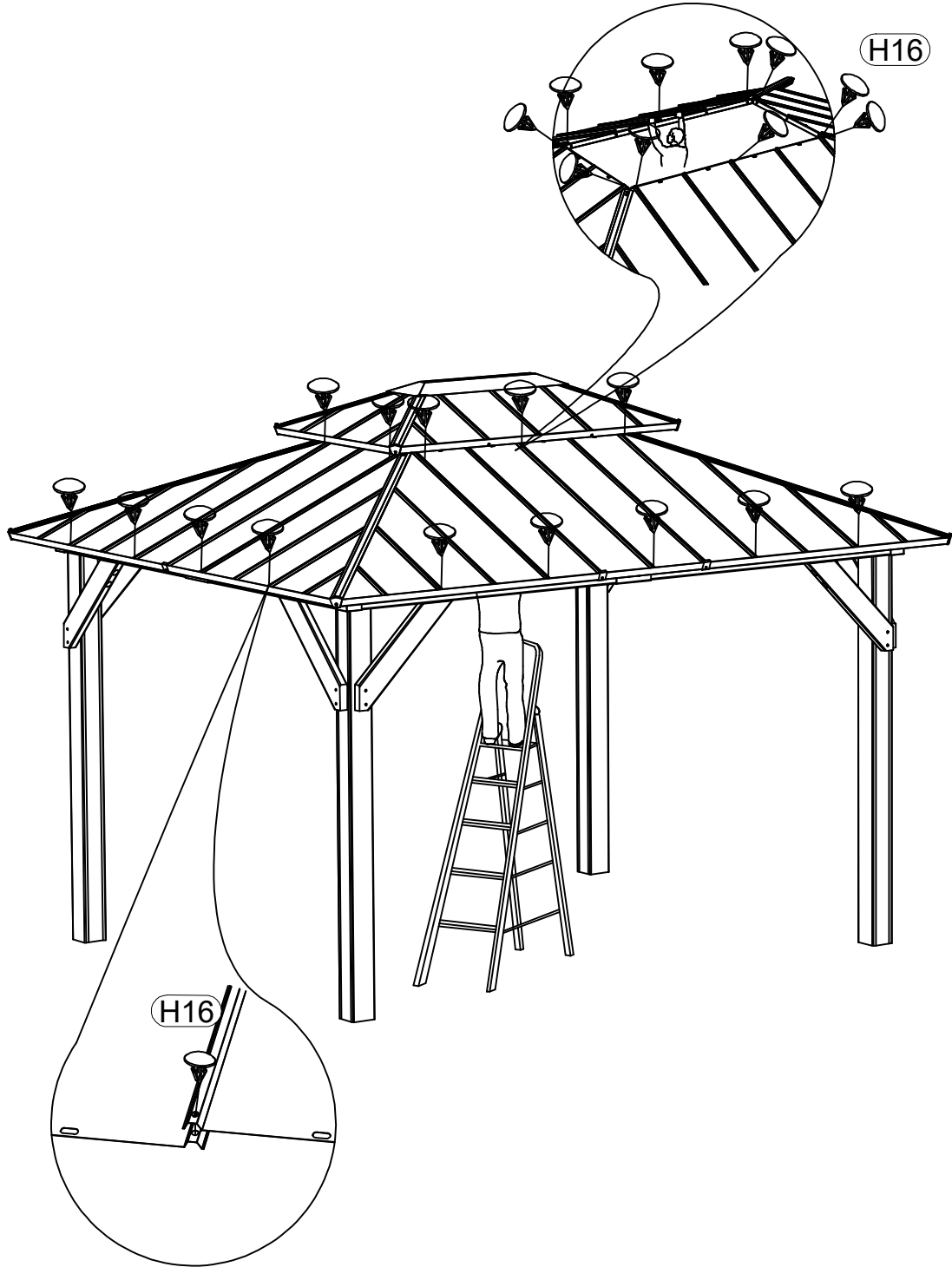

H16			28
-----	---	--	----



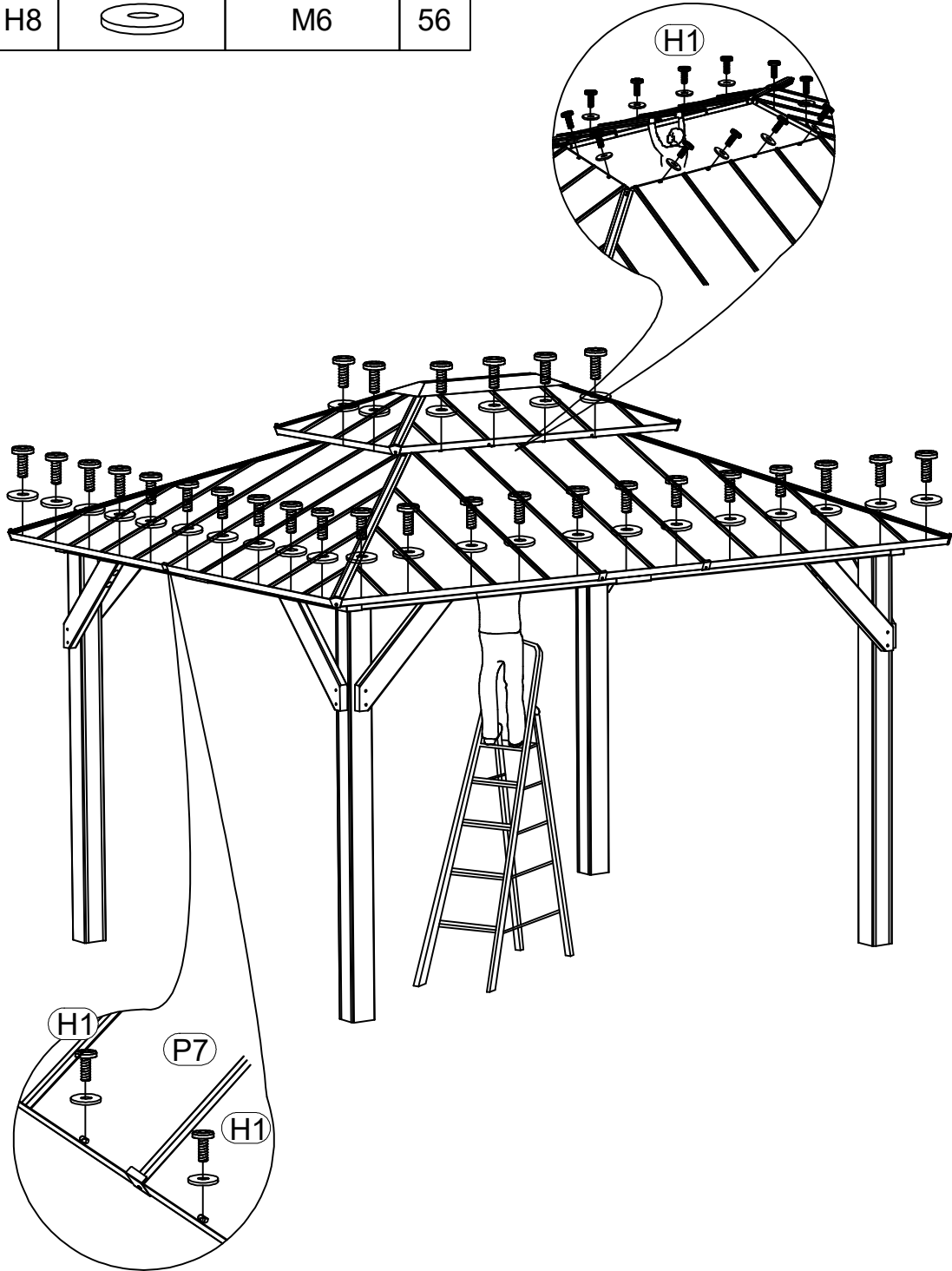

H1		M6X15	56
H8		M6	56

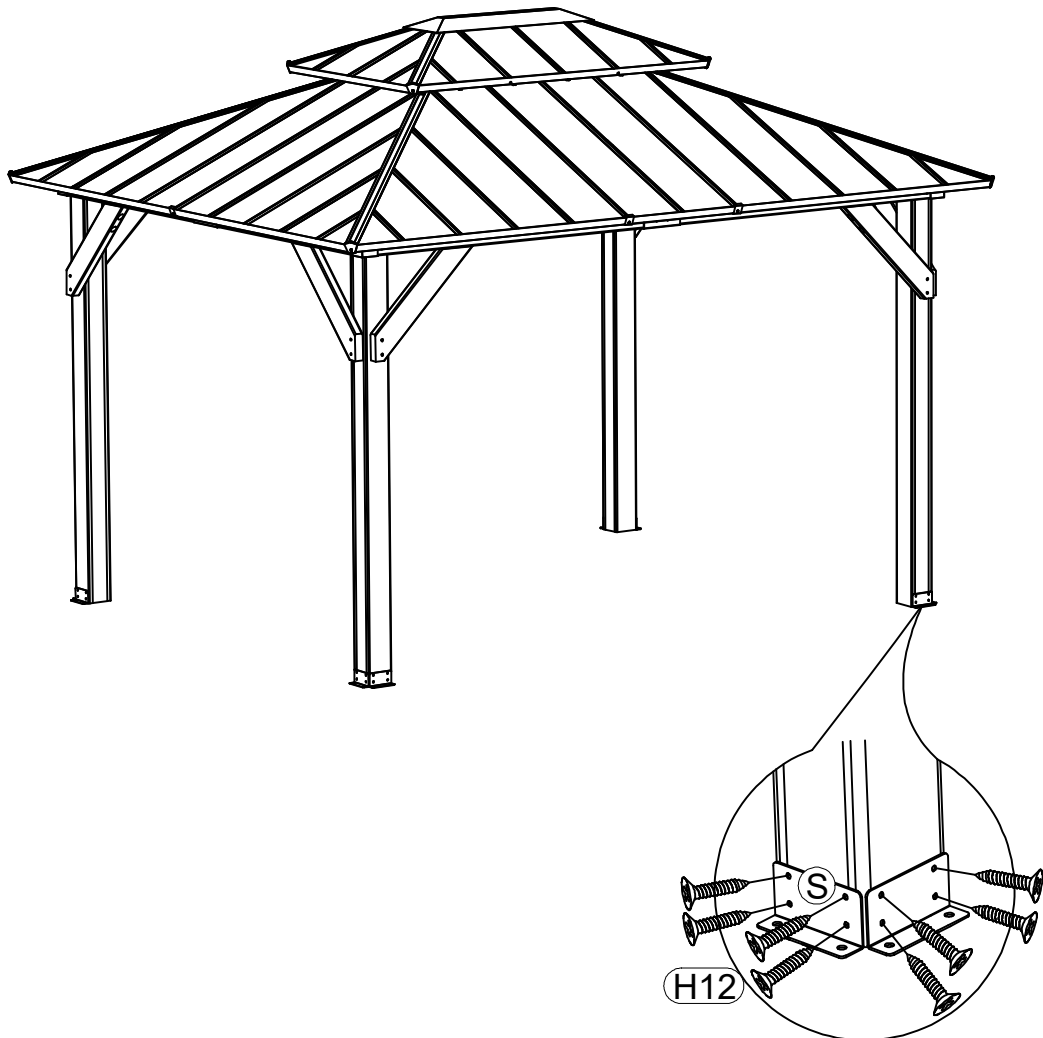

27

S		8	H12		M4X25	32
---	---	---	-----	--	-------	----



HQ1			8
HQ2		M8X70	8

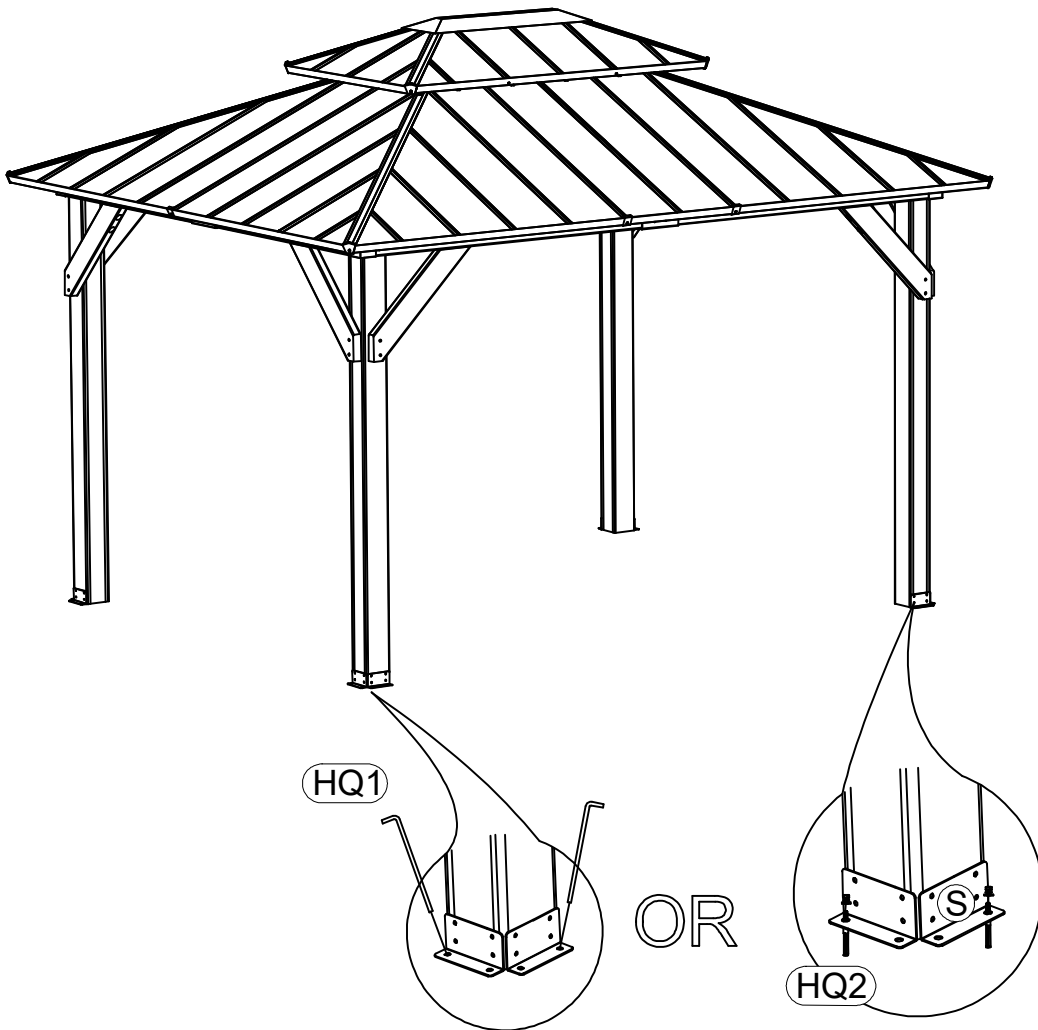

REGULAR MAINTENANCE:

LC137

Cleaning:

Regularly clean the gazebo to remove dirt, dust, and debris. Use a mild detergent and water solution to clean the curtains, then wait for them to thoroughly dry.

Important Note:

When washing, do not use steam heating or water temperatures exceeding 100 degrees Fahrenheit. Do not use bleach. Do not use solvents. Do not use chlorine-containing cleaners. Please keep the gazebo distanced from heat sources and open flames at all times.

Inspect for Damage:

Routinely inspect the structure for signs of wear, such as loose screws. Promptly repair any damage to prevent further deterioration.

Rust Prevention:

Apply a rust-resistant coating or paint to the metal frame as needed to prevent corrosion and maintain its appearance.

Safety Hazards:

When snow accumulates too heavily during the winter, please clear it promptly to prevent exceeding the roof's weight limit and to avoid safety issues such as collapse.