

---

# Instruction

---

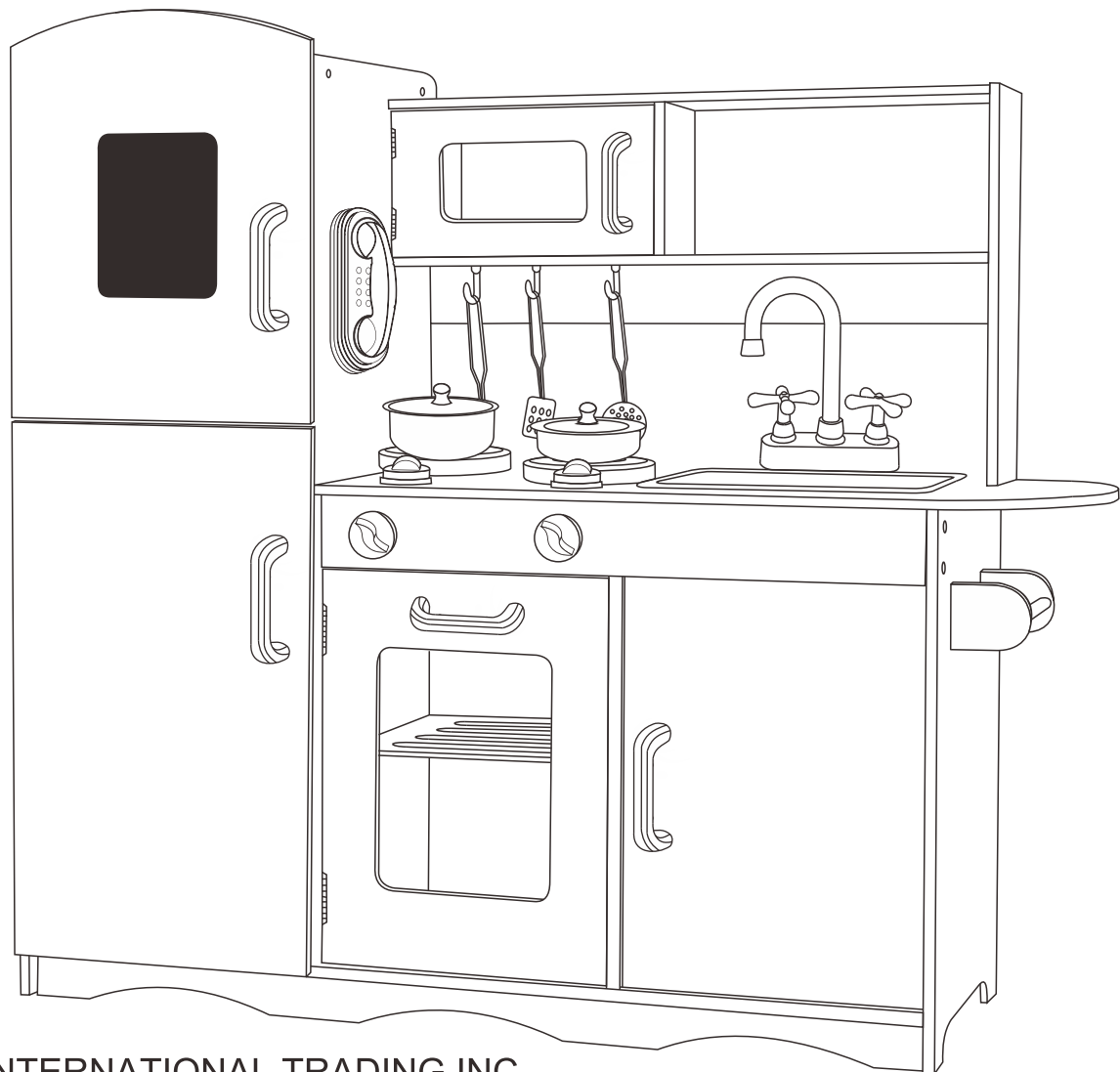

NATURE INTERNATIONAL TRADING INC.  
597 BEAVER CREEK CT, BRIGHTON, CO  
80601

Email Add: [todefull@todefull.com](mailto:todefull@todefull.com)

## **USER'S MANUAL**

---

### **Kids Kitchen toy ETD042**

### **KEEP INSTRUCTIONS FOR FUTURE USE**

Read all instructions before assembling and using the product.

Never use this product if any parts are missing, damaged, or broken. Contact seller for replacement parts and instructional literature if needed. Never substitute parts.

**IMPORTANT INFORMATION:**

1. Before installing, please refer to the manual to check each part.
2. If you experience any issue during the installation, please reach out to our service team for assistance: [todefull@todefull.com]

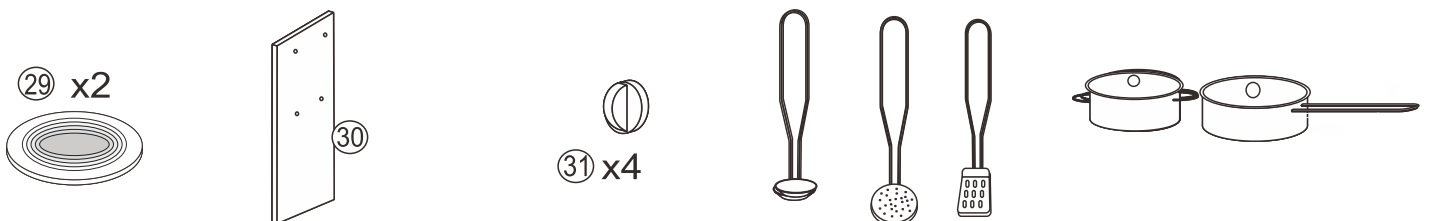
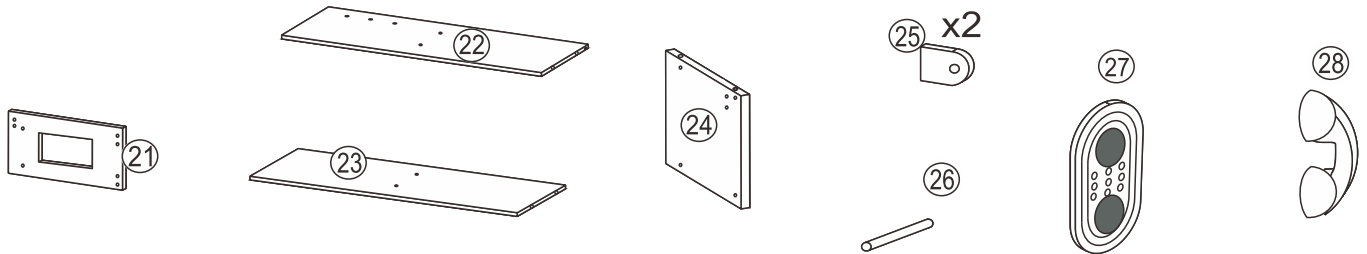
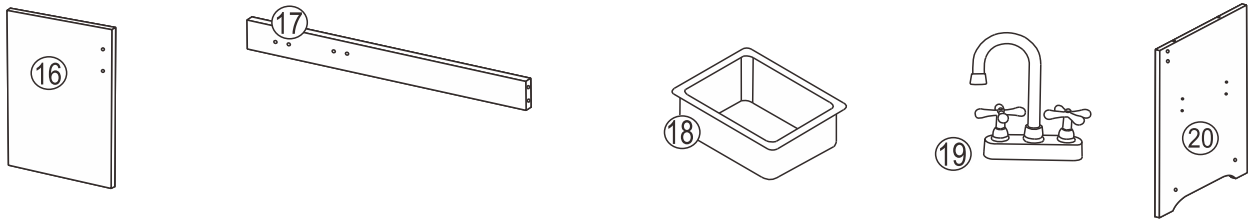
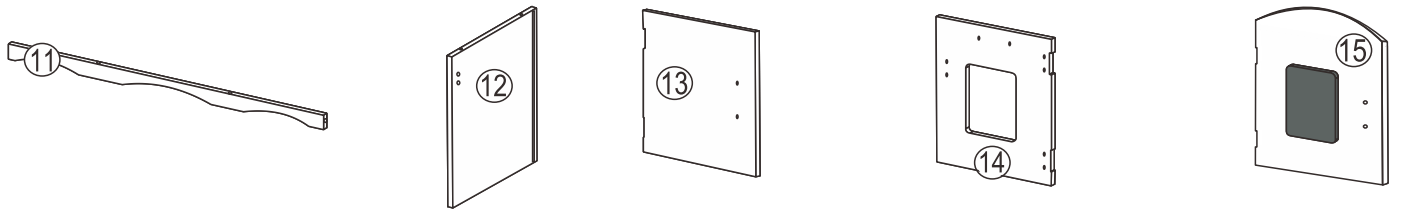
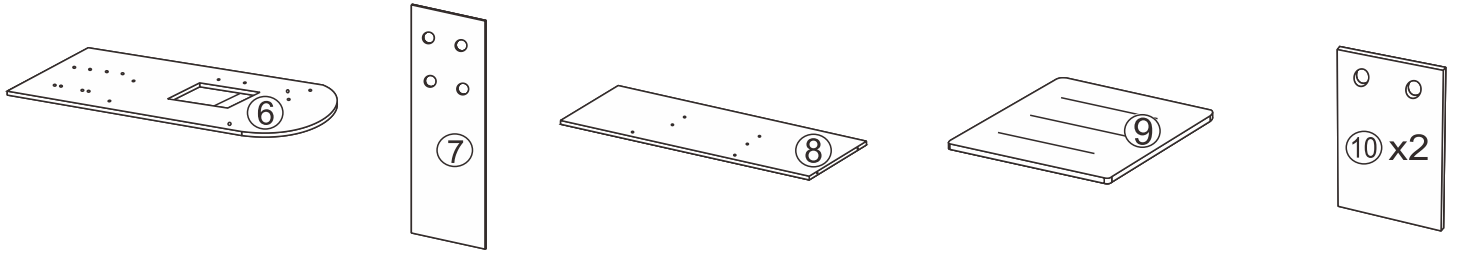
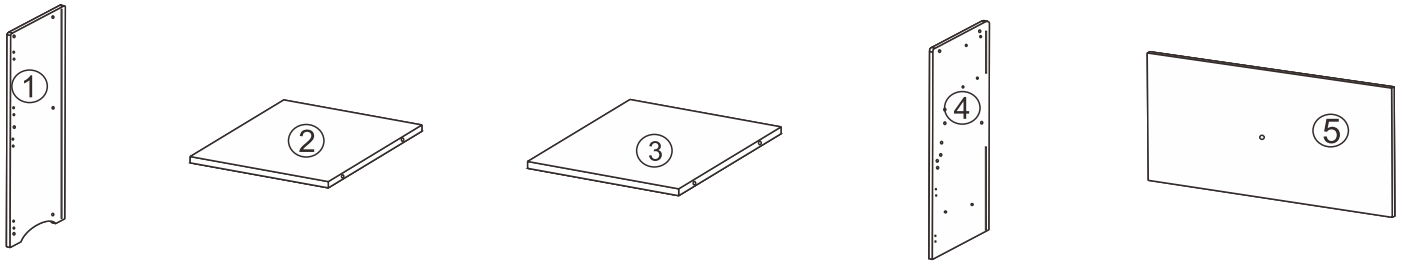

**IMPORTANT INFORMATION:**

1. Before installing, please refer to the manual to check each part.
2. If you experience any issue during the installation, please reach out to our service team for assistance: [todefull@todefull.com]

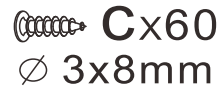

**1**

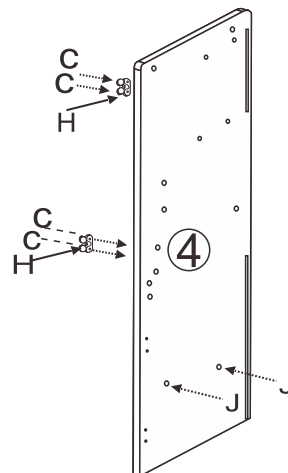
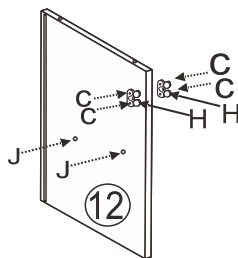
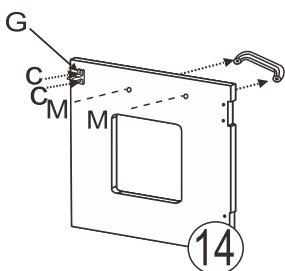
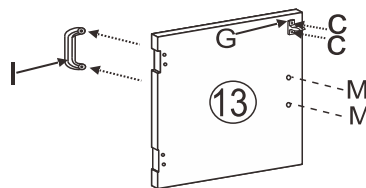
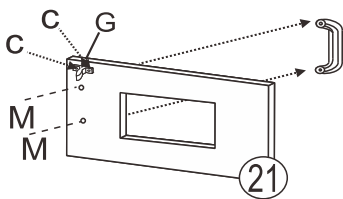
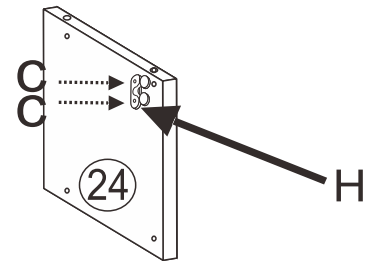
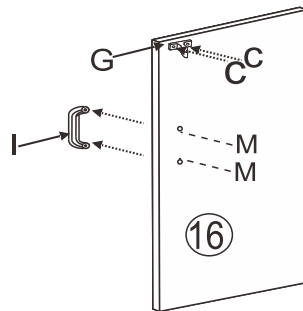
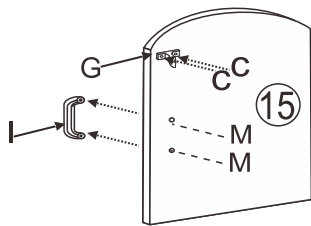

	<b>Cx20</b>
	<b>Mx10</b>
	<b>Jx4</b>
	<b>Gx5</b>
	<b>Hx5</b>
	<b>Ix5</b>

**IMPORTANT INFORMATION:**

1. Before installing, please refer to the manual to check each part.
2. If you experience any issue during the installation, please reach out to our service team for assistance: [todefull@todefull.com]

**2**

 Mx4

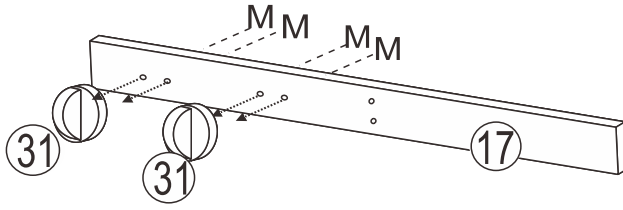

**3**

 Ax2

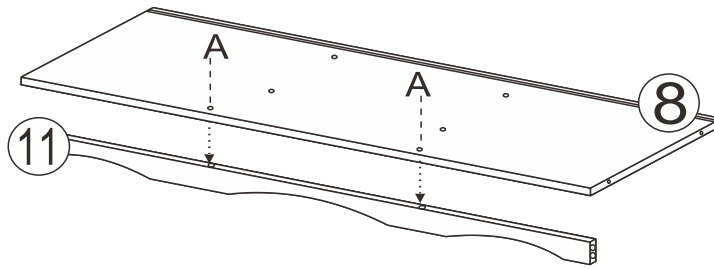

**4**

 Ax4

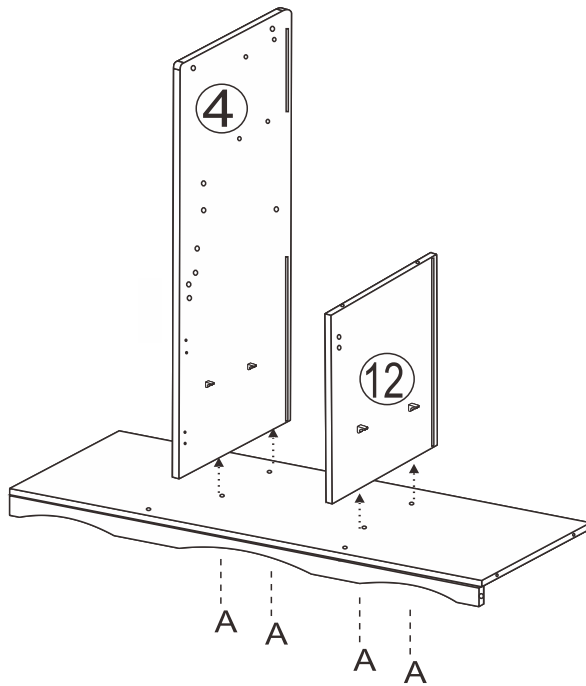

**5**

 Ax6

 Bx1

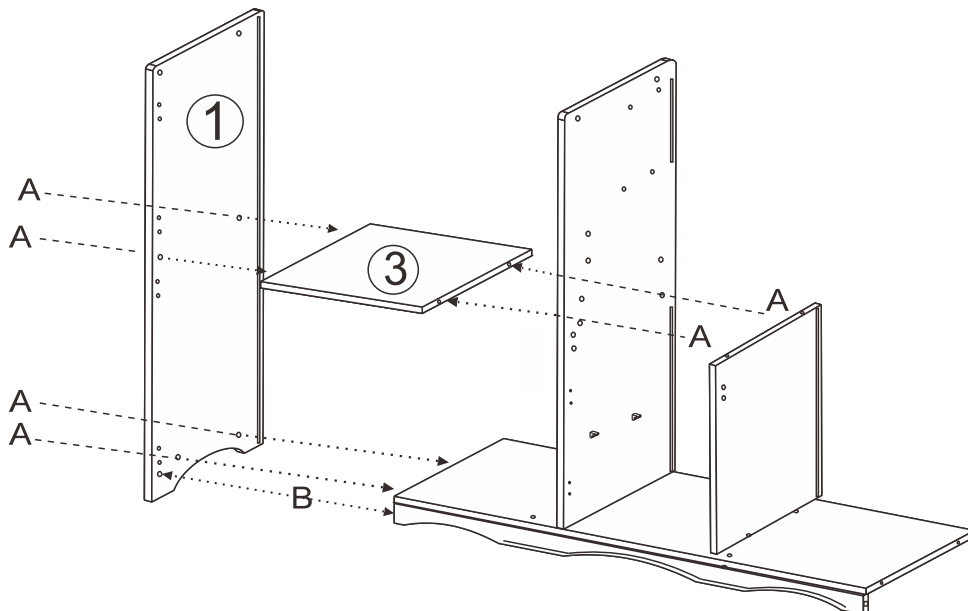

**IMPORTANT INFORMATION:**

- 1. Before installing, please refer to the manual to check each part.
- 2. If you experience any issue during the installation, please reach out to our service team for assistance: [todefull@todefull.com]

# 6

 Mx2

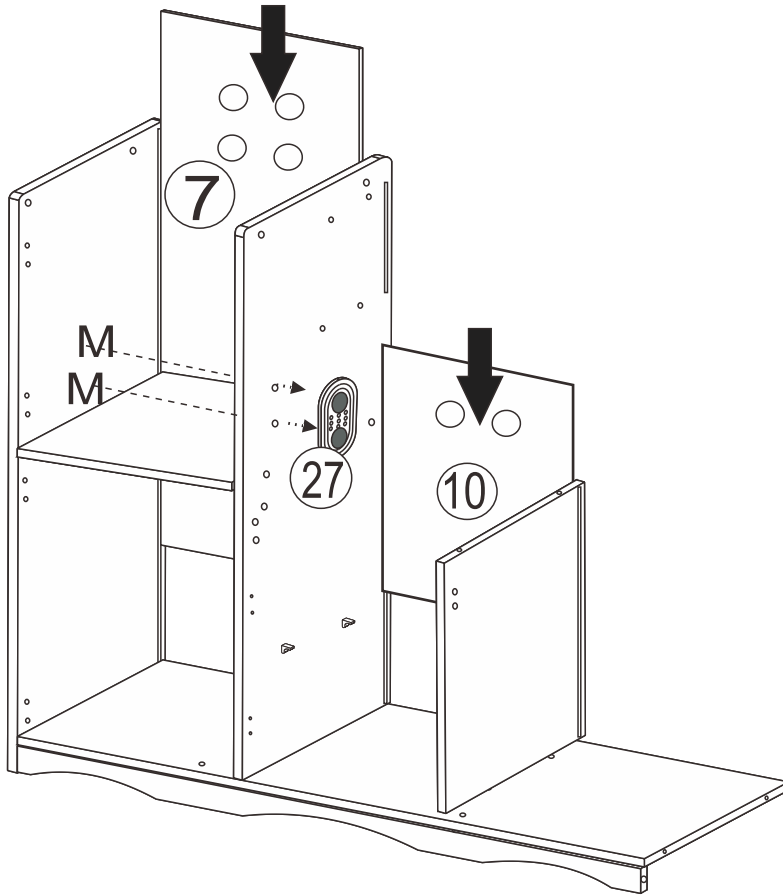

# 7

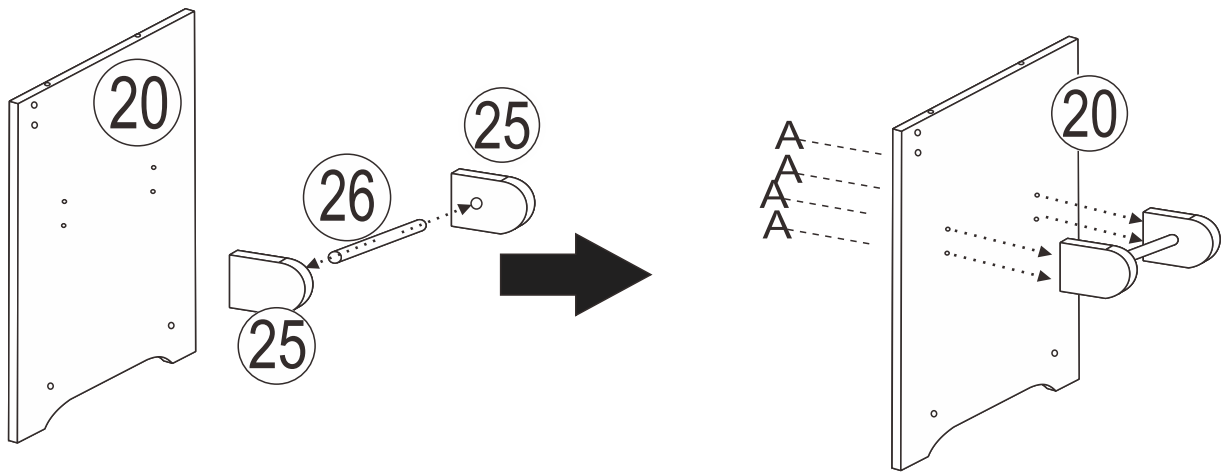

 Ax4



**IMPORTANT INFORMATION:**



- 1. Before installing, please refer to the manual to check each part.
- 2. If you experience any issue during the installation, please reach out to our service team for assistance: [todefull@todefull.com]

# 8

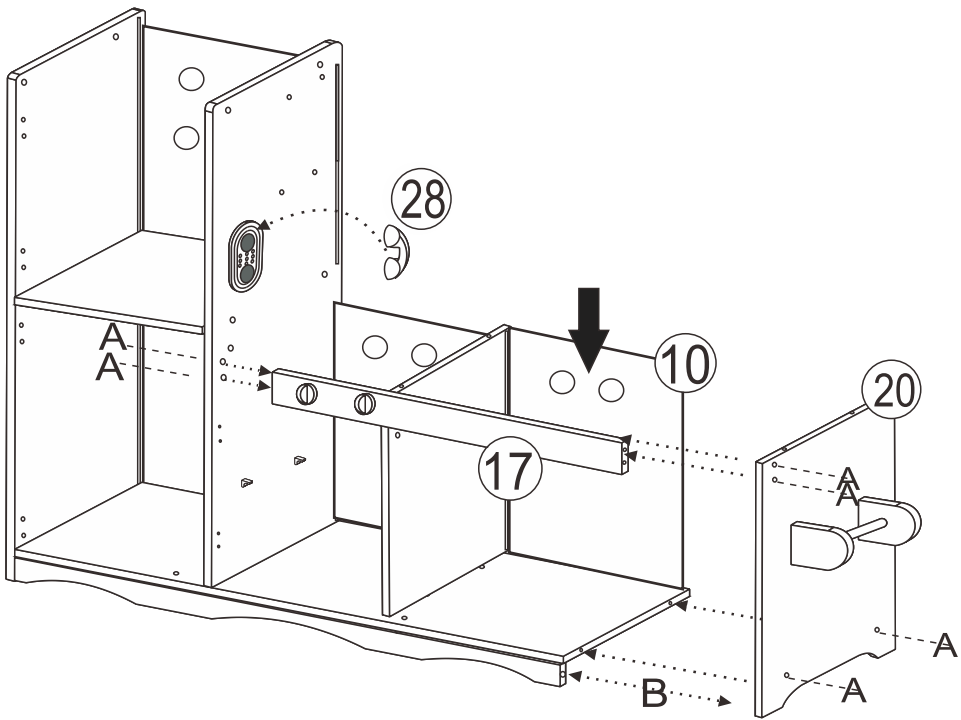
-  Ax6
-  Bx1



# 9

-  Mx4
-  Nx6

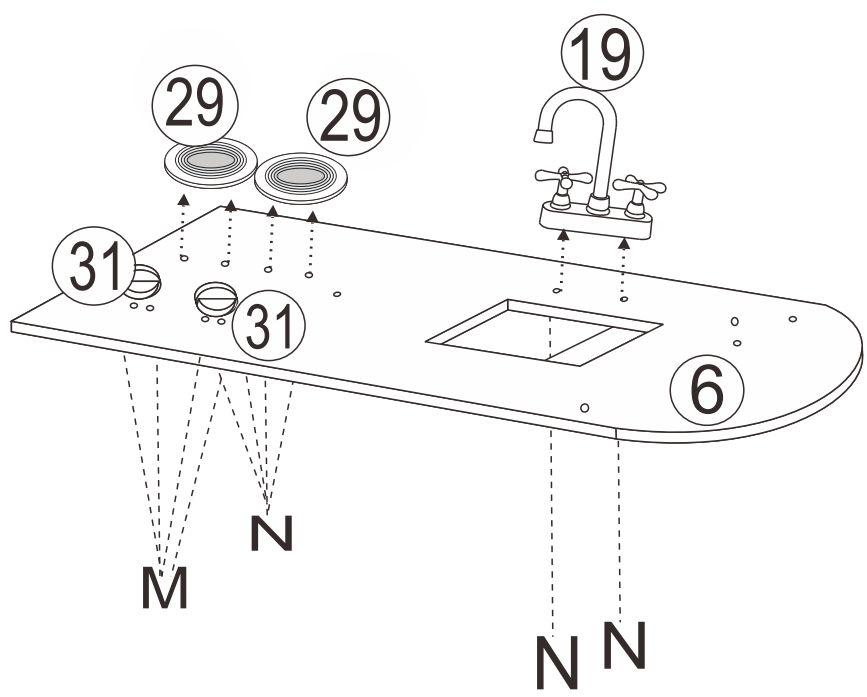

**IMPORTANT INFORMATION:**

1. Before installing, please refer to the manual to check each part.
2. If you experience any issue during the installation, please reach out to our service team for assistance: [todefull@todefull.com]

# 10

 Ax4

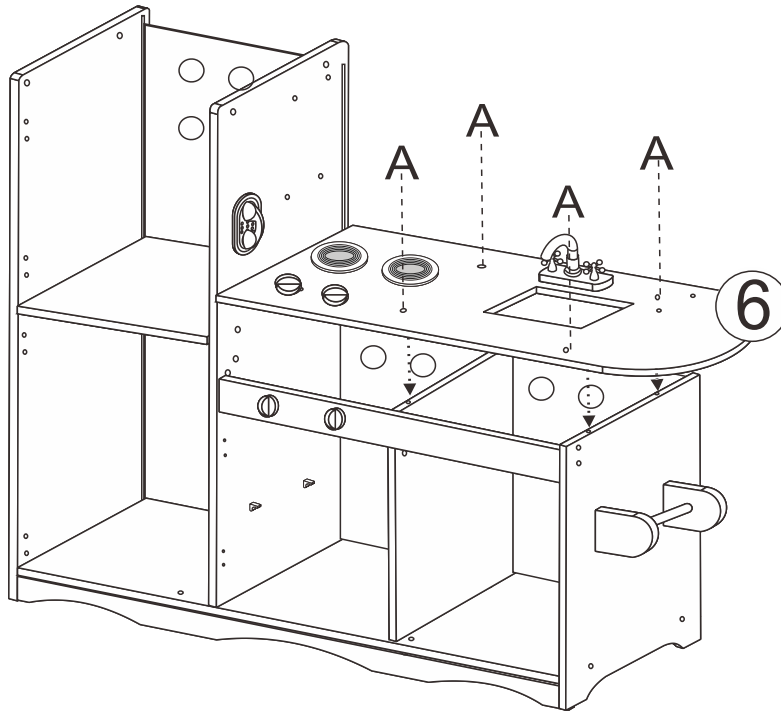

# 11

 Ax4

 Nx3

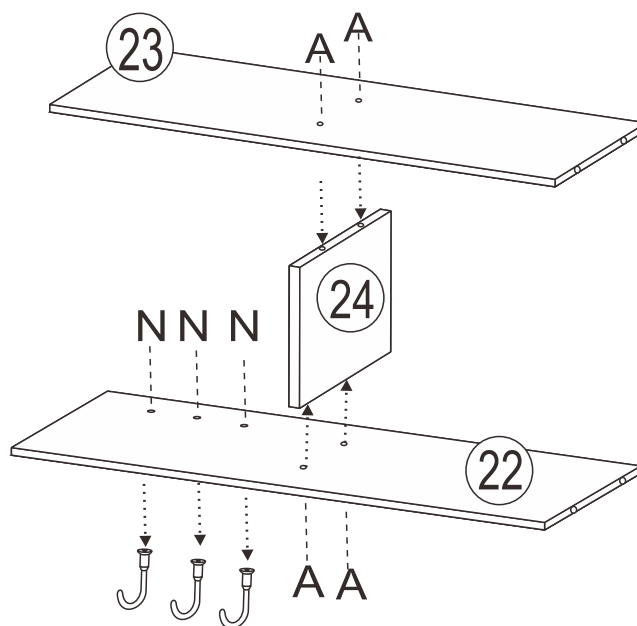

**IMPORTANT INFORMATION:**

1. Before installing, please refer to the manual to check each part.
2. If you experience any issue during the installation, please reach out to our service team for assistance: [todefull@todefull.com]

**12**

 Ax6

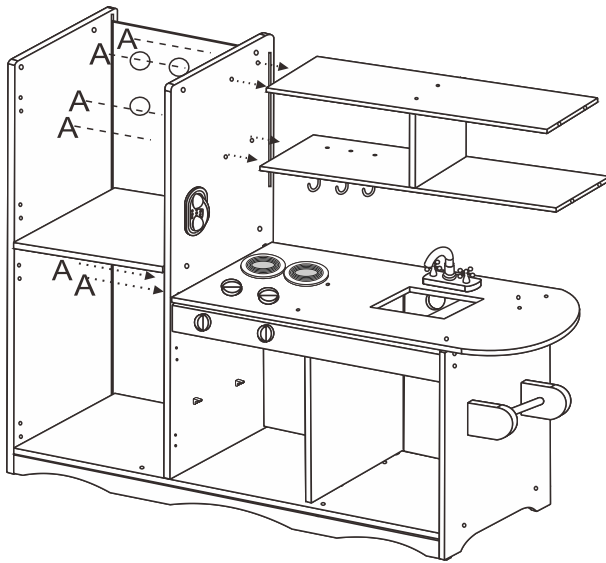

**13**

 Ax4

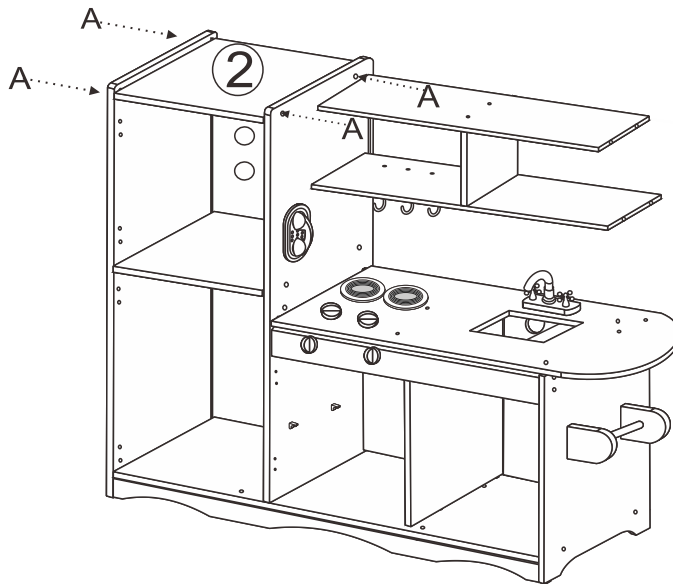

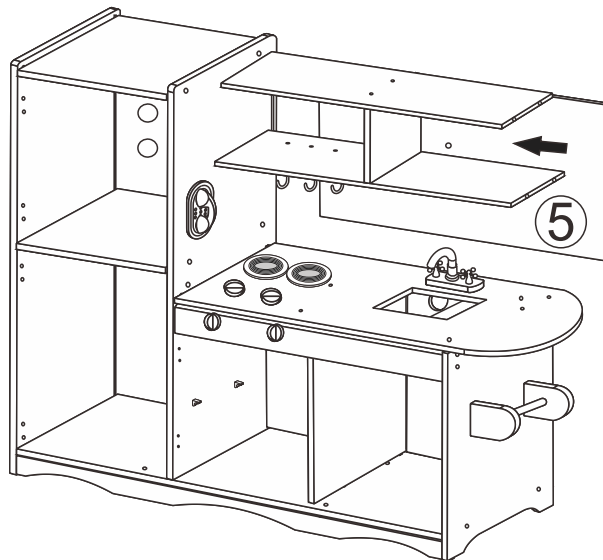

**14**



**IMPORTANT INFORMATION:**



1. Before installing, please refer to the manual to check each part.
2. If you experience any issue during the installation, please reach out to our service team for assistance: [todefull@todefull.com]

# 15

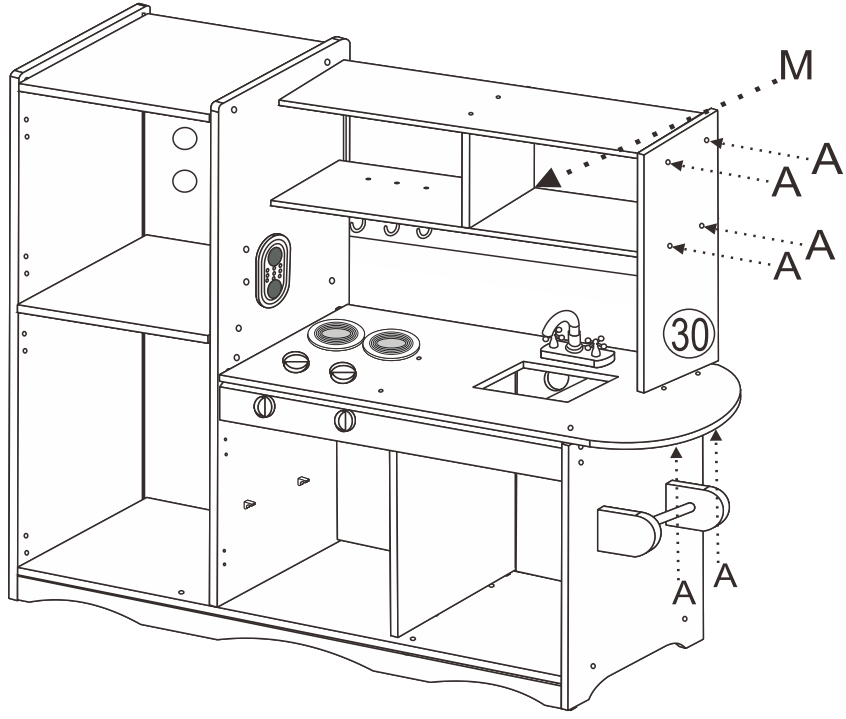
 Ax6
 Mx1



# 16

 Cx40
 Fx8
 Kx2

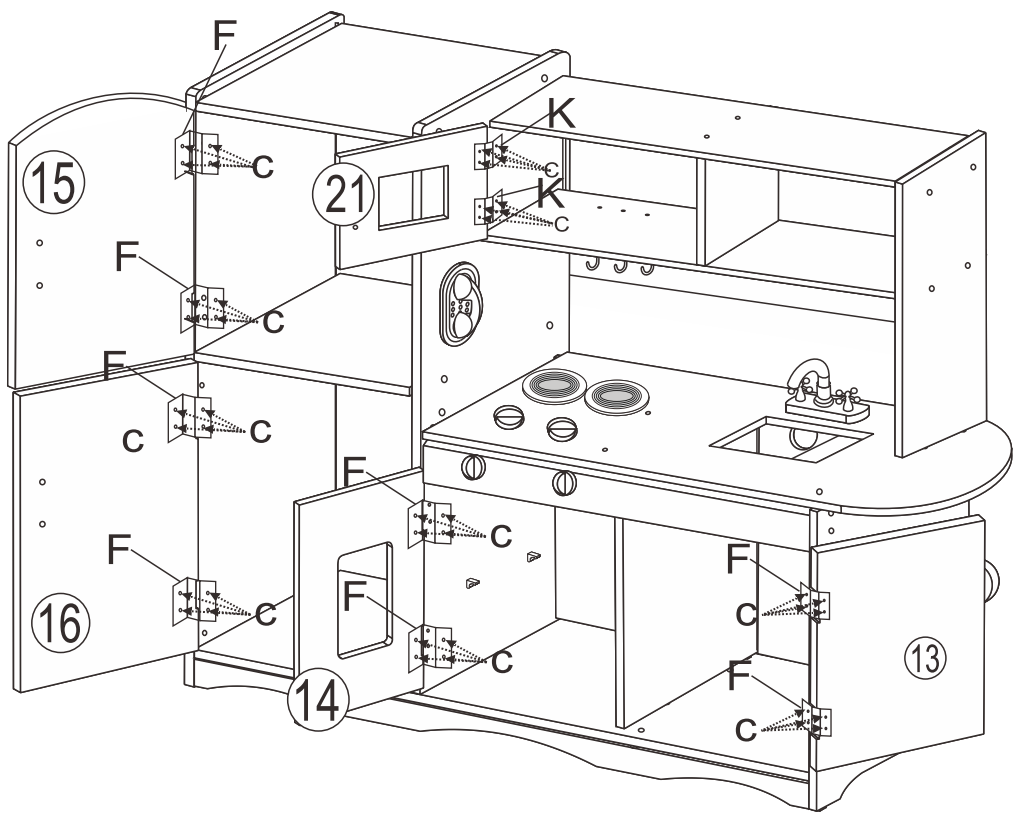

**IMPORTANT INFORMATION:**

- 1. Before installing, please refer to the manual to check each part.
- 2. If you experience any issue during the installation, please reach out to our service team for assistance: [todefull@todefull.com]

# 17

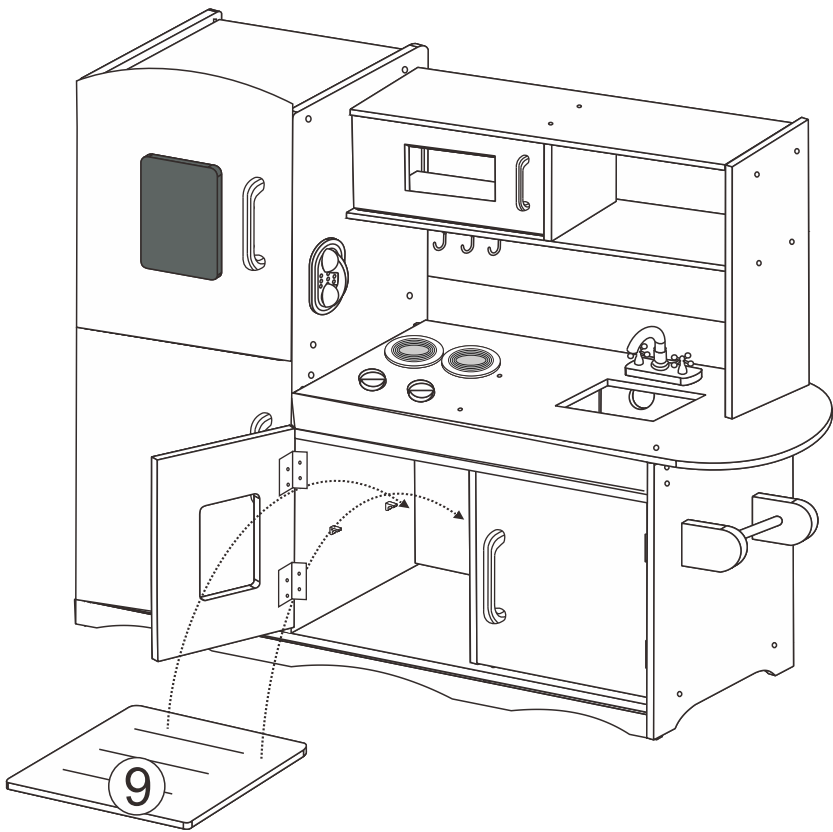

# 18

