

Installation & Assembly

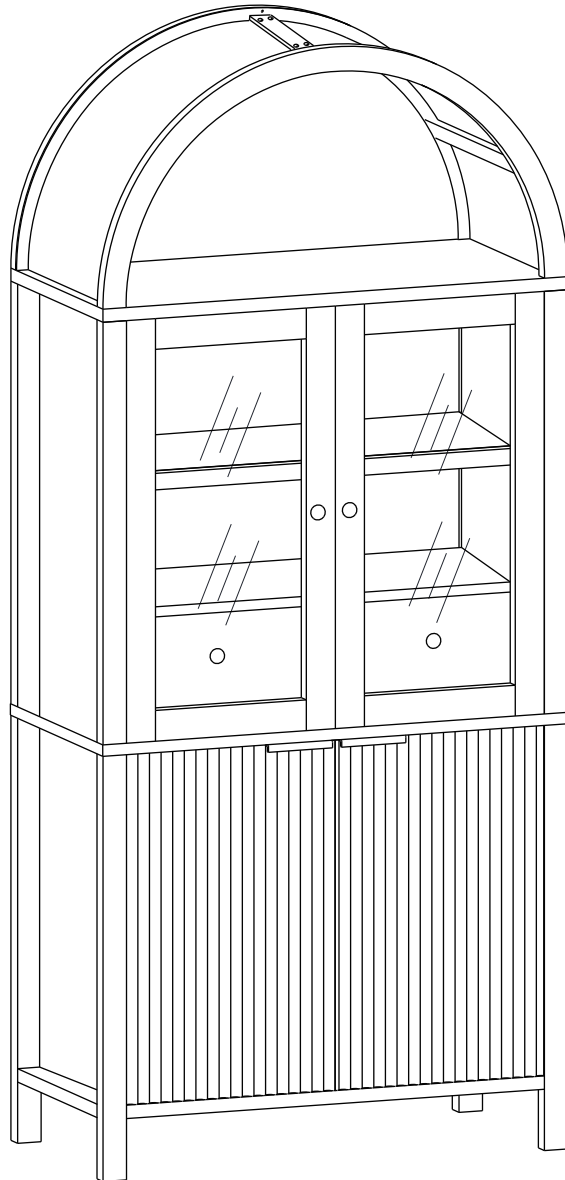

As this item contains many parts, please read the installation instruction carefully before installation . Please use tools properly and carefully.

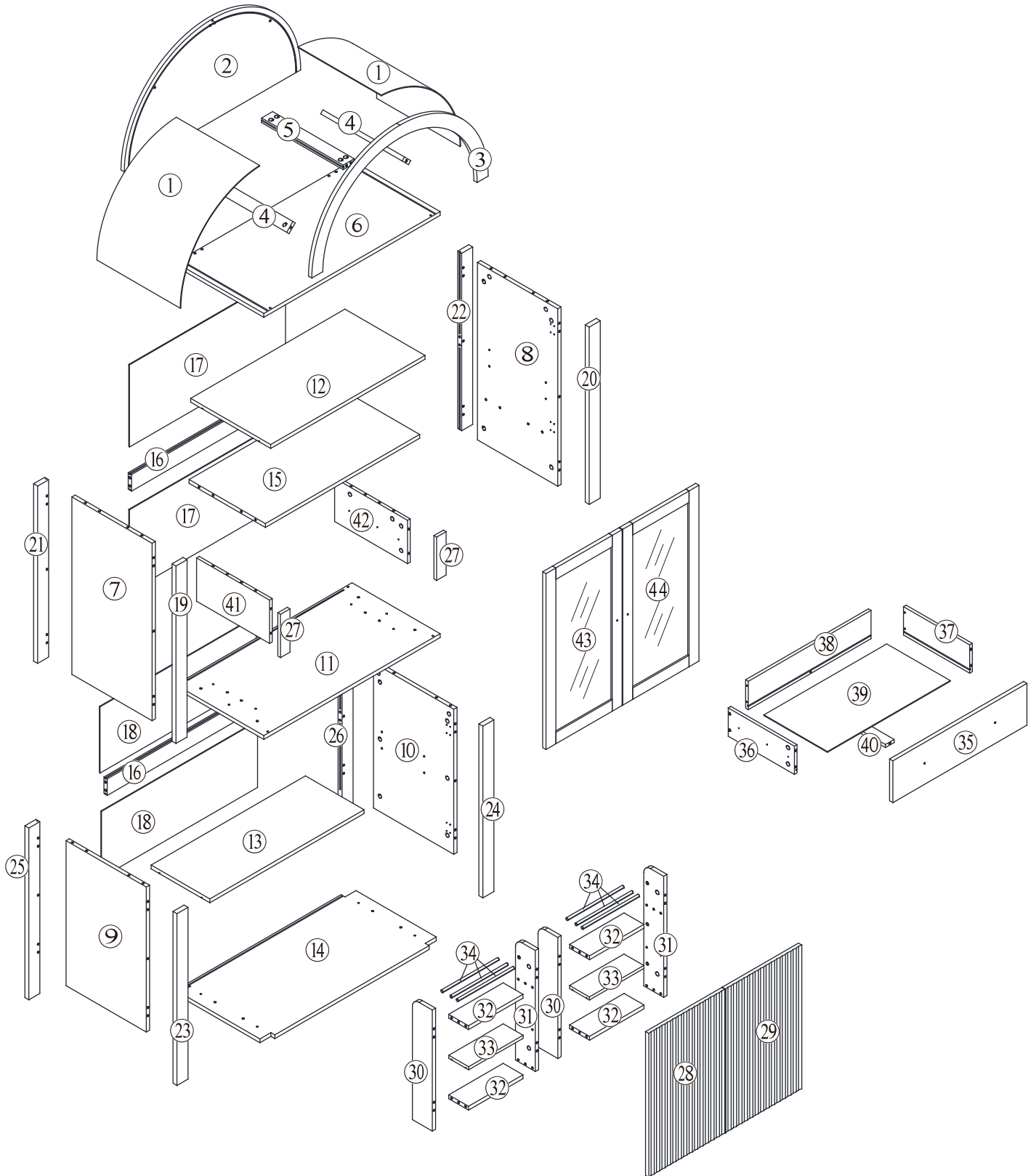









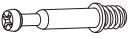

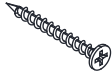





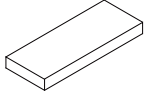

Assembly Instruction







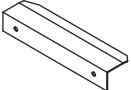





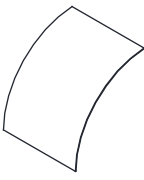
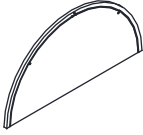







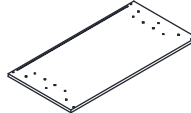
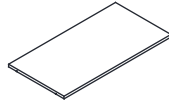
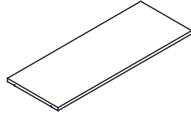
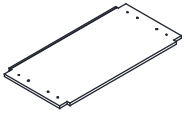
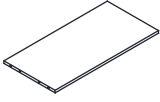

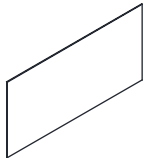
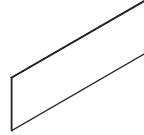
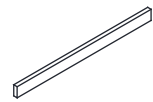
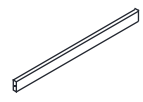

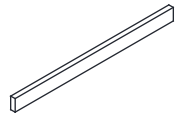
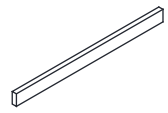
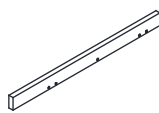

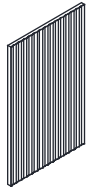
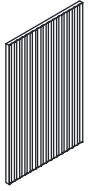
Components - Fittings

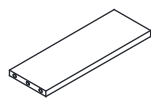
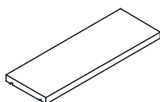
Please check you have all the panels listed below

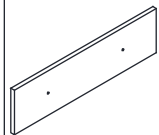
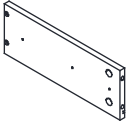
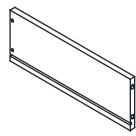
Note: The quantities below are the correct amount to complete the assembly. In some cases, more fittings may be supplied than required.

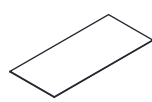
 A: 92PCS	 B: 92PCS	 $\varnothing 4 \times 35 \text{mm}$ C: 18PCS	 $\varnothing 4 \times 30 \text{mm}$ D: 5PCS	 $\varnothing 3.5 \times 10 \text{mm}$ E: 20PCS	 F: 4PCS	
 M4x18mm G: 4PCS	 H: 8PCS	 $\varnothing 3.5 \times 14 \text{mm}$ I: 52PCS	 $\varnothing 5 \times 25 \text{mm}$ J: 16PCS	 $\varnothing 6 \times 30 \text{mm}$ K: 64PCS	 L: 4PCS	 M: 2PCS
 N: 2PCS	 O: 1PC	 $\varnothing 5 \times 40 \text{mm}$ P: 1PC	 Q: 16PCS	 $\varnothing 3 \times 16 \text{mm}$ R: 16PCS	 S: 1PCS	 T: 2PCS
 U: 92PCS	 V: 1PC					

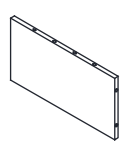
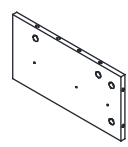
Assembly Instruction

							
1: 2PCS	2: 1PC	3: 1PC	4: 2PCS	5: 1PC	6: 1PC	7: 1PC	
							
8: 1PC	9: 1PC	10: 1PC	11: 1PC	12: 1PC	13: 1PC	14: 1PC	
							
15: 1PC	16: 2PCS	17: 2PCS	18: 2PCS	19: 1PC	20: 1PC	21: 1PC	
							
22: 1PC	23: 1PC	24: 1PC	25: 1PC	26: 1PC	27: 2PCS	28: 1PC	
							
29: 1PC	30: 2PCS	31: 2PCS	32: 4PCS	33: 2PCS	34: 6PCS	35: 1PC	36: 1PC
							
37: 1PC	38: 1PC	39: 1PC	40: 1PC	41: 1PC	42: 1PC	43: 1PC	44: 1PC

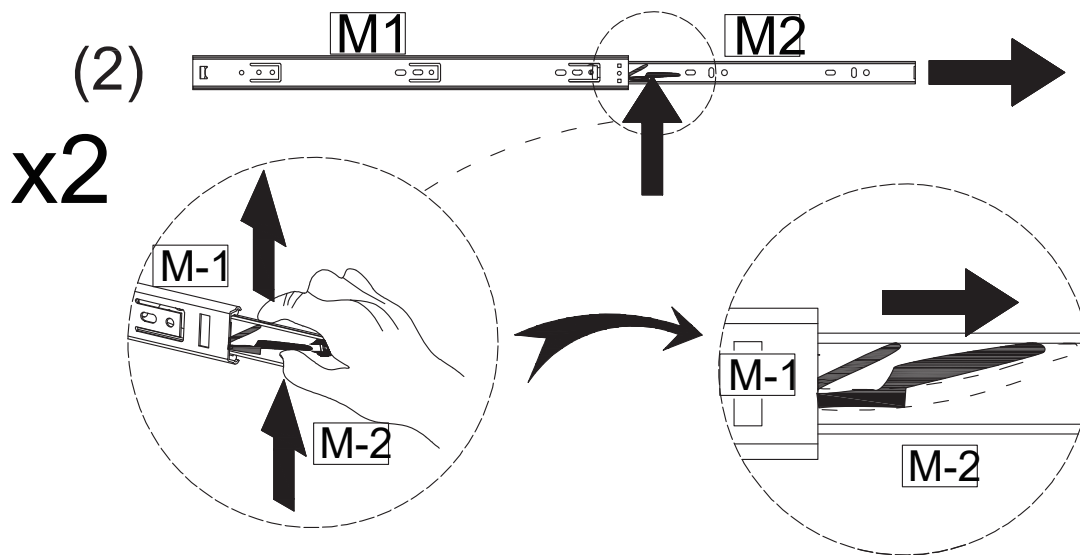
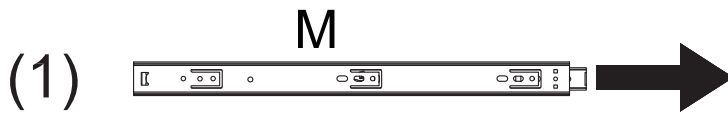
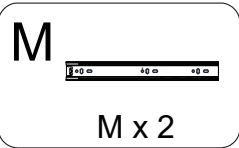

Move the black paddle upward and pull out (M2) to the right.
Déplacez la palette noire vers le haut et tirez (M2) vers la droite.

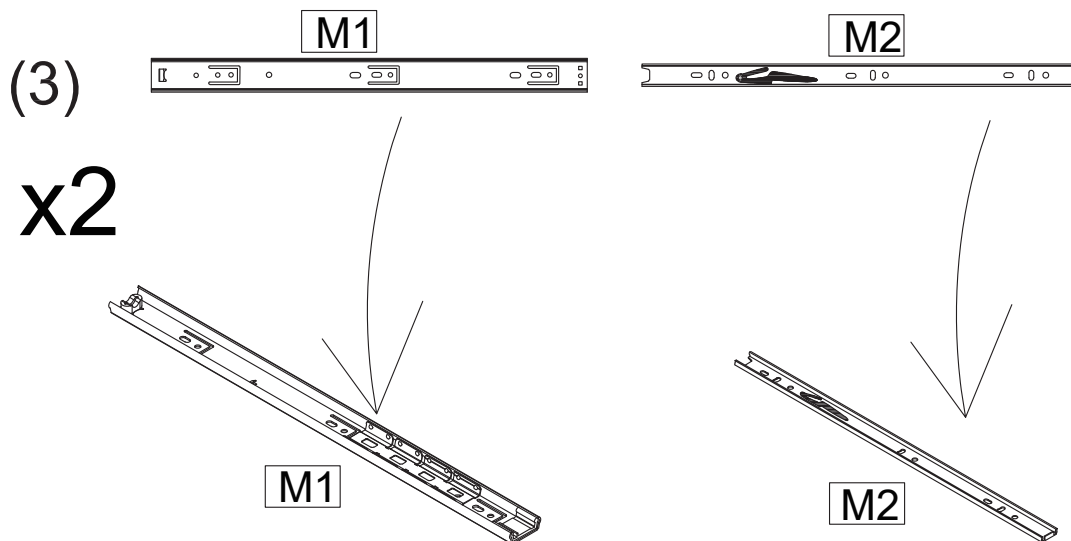

Step 1

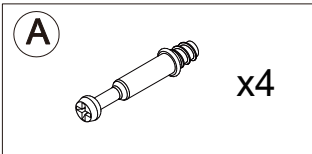
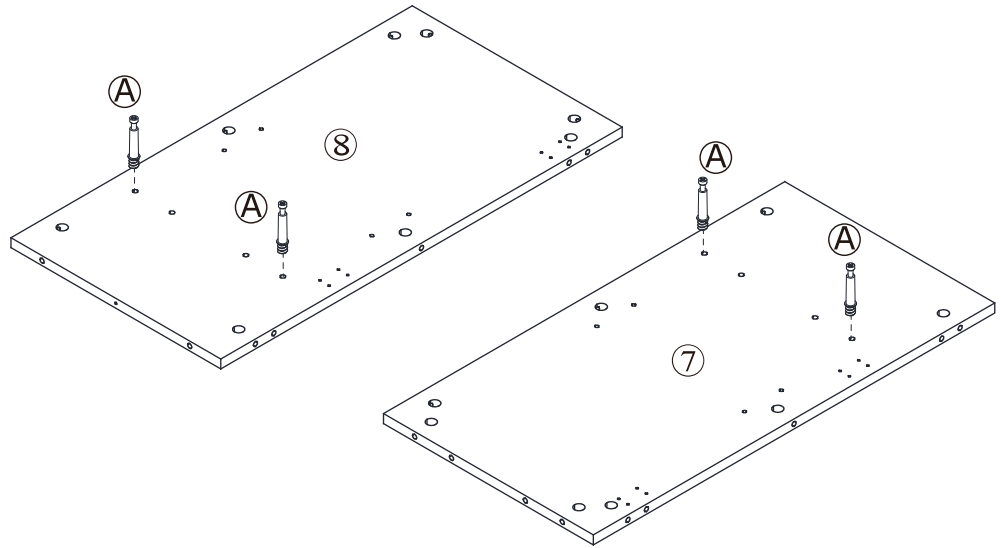

Step 2

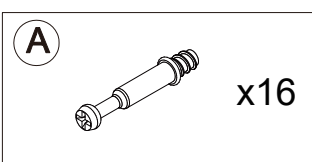
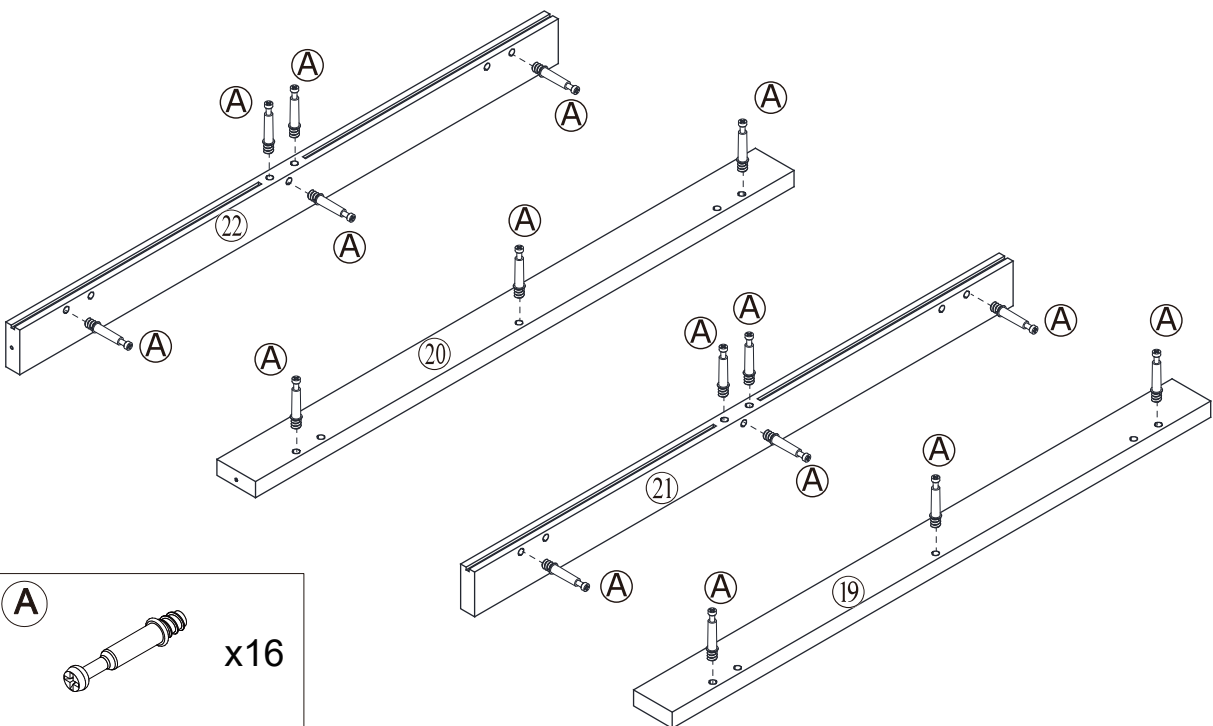

Step 3

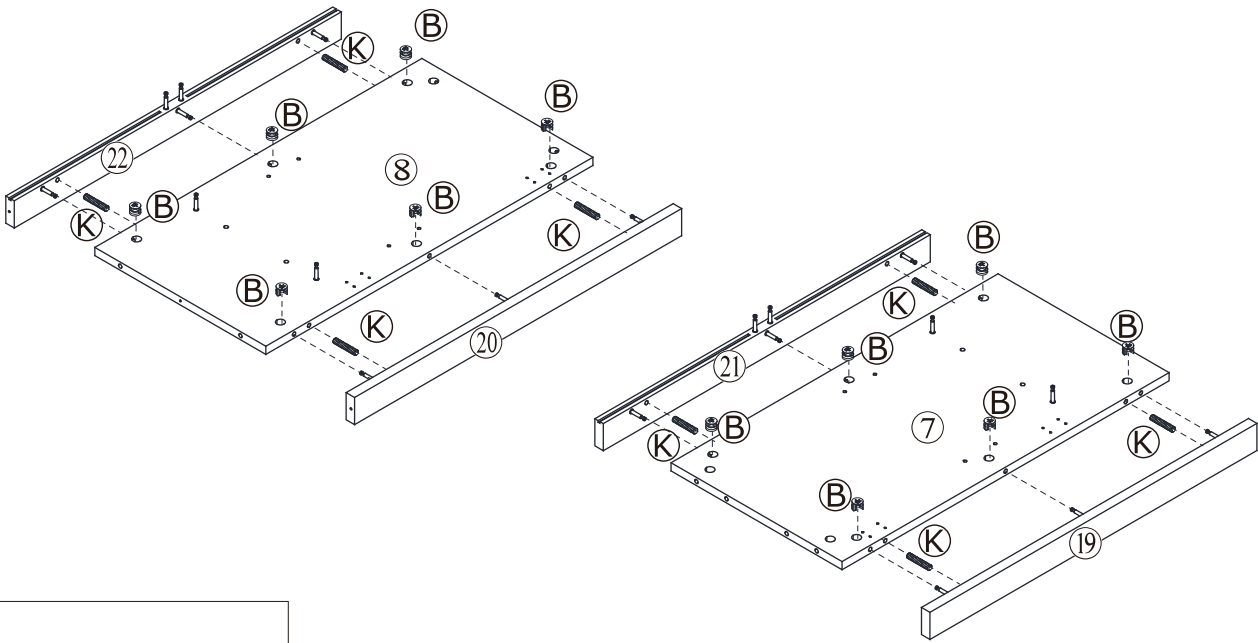

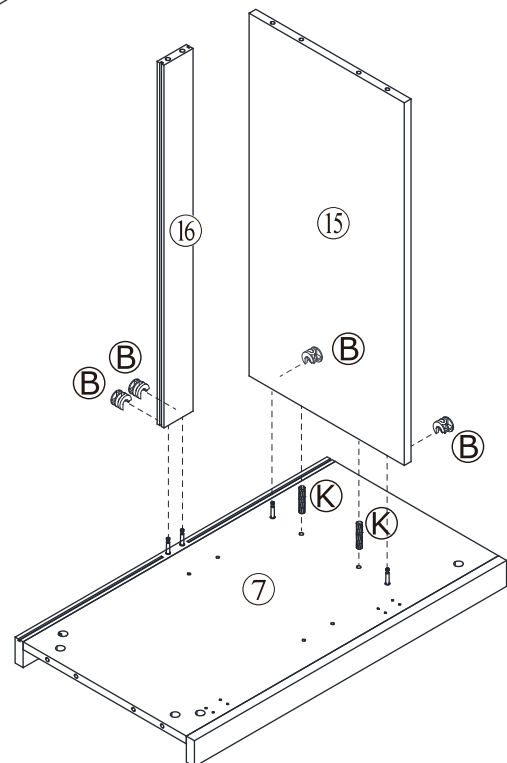
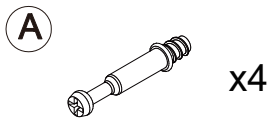
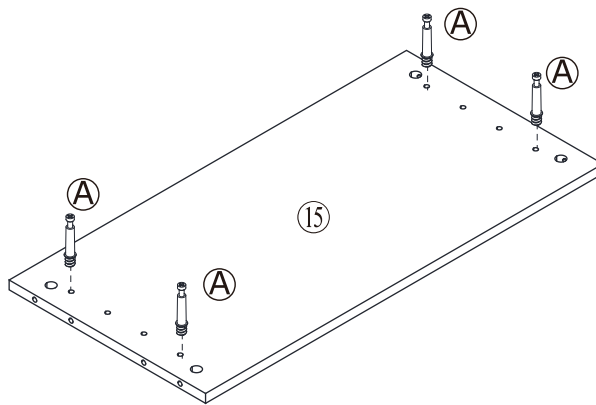

Step 4



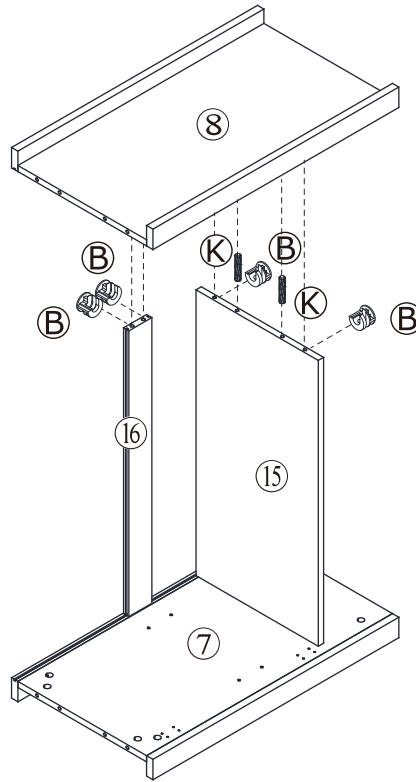

Step 5

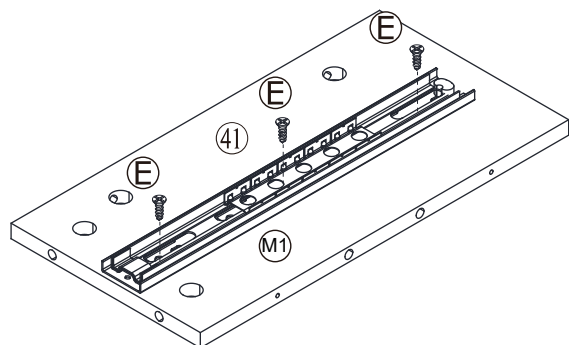
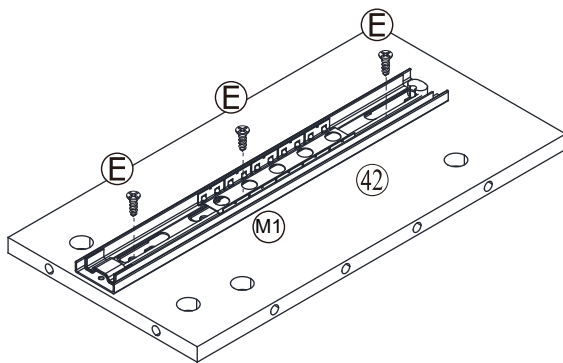

B		x4
K		x2

Step 6



E		x6
M		x2



Step 7

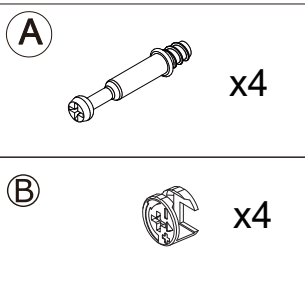
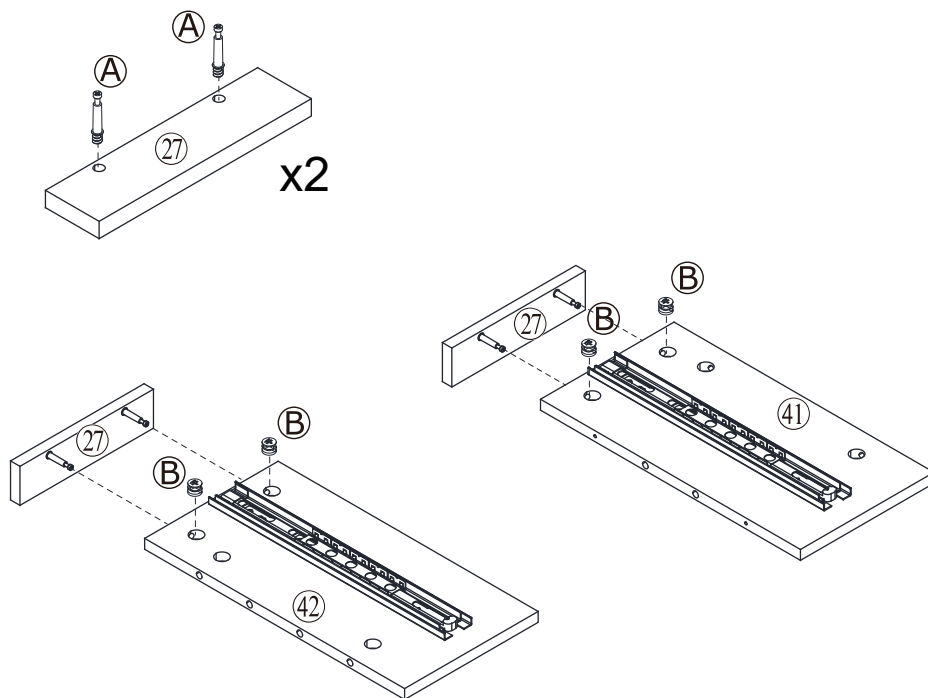



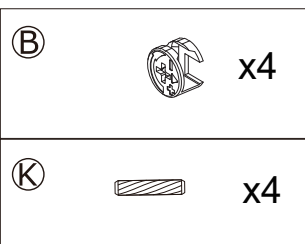
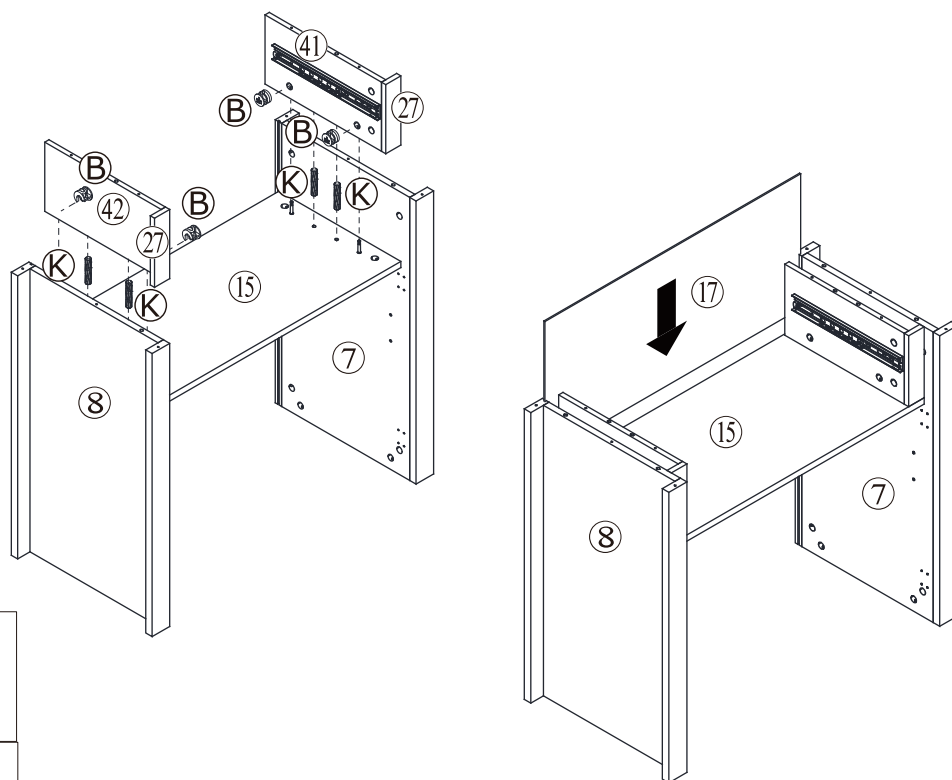

Step 8

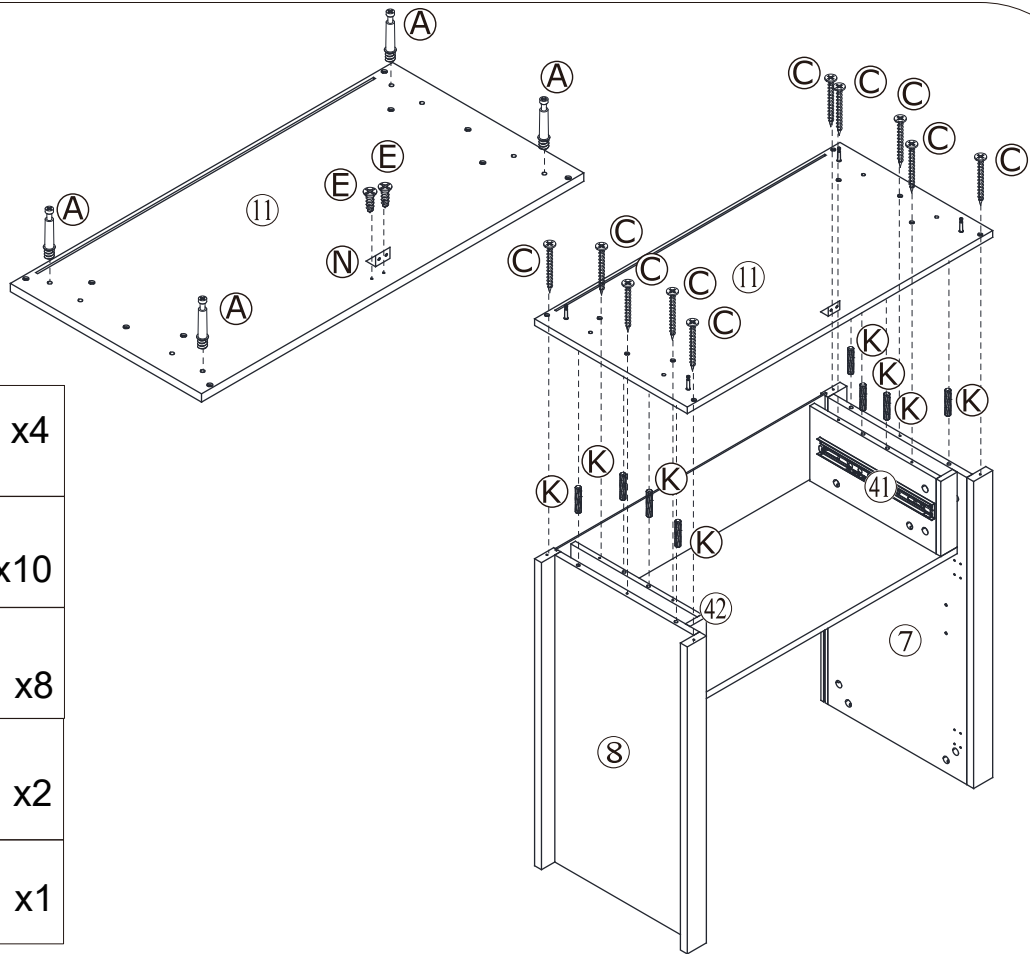

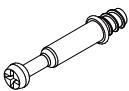
Step 9



A		x4
C		x10
K		x8
E		x2
N		x1

Step 10

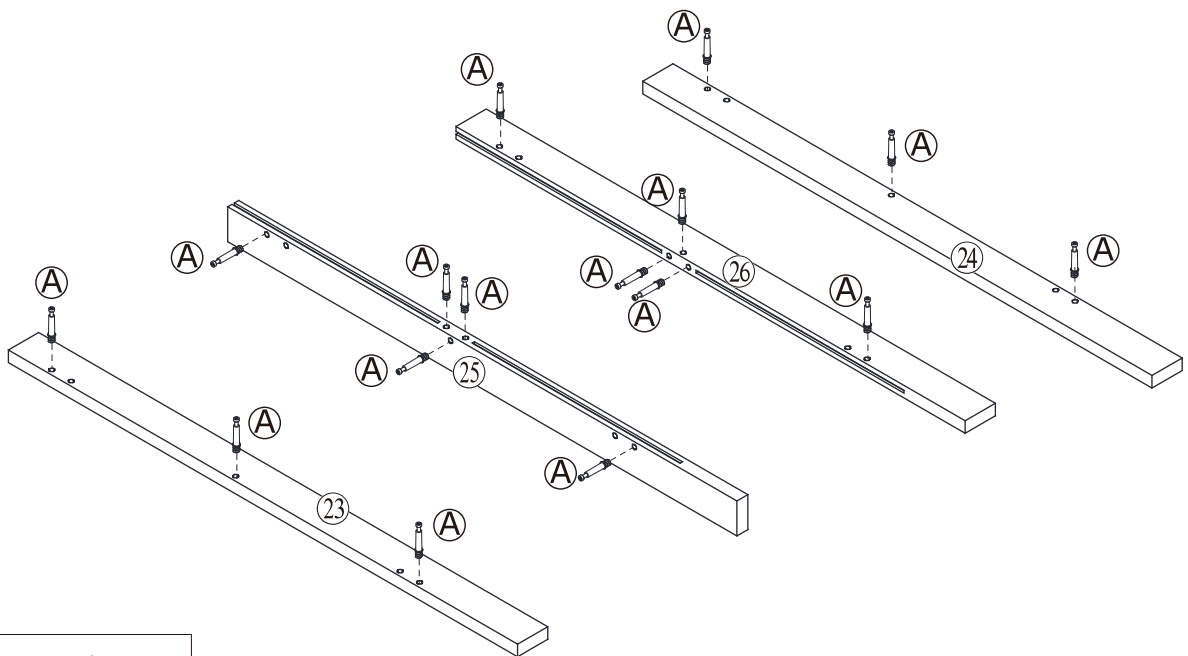

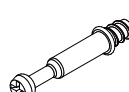
A		x16
----------	---	-----

Step 11

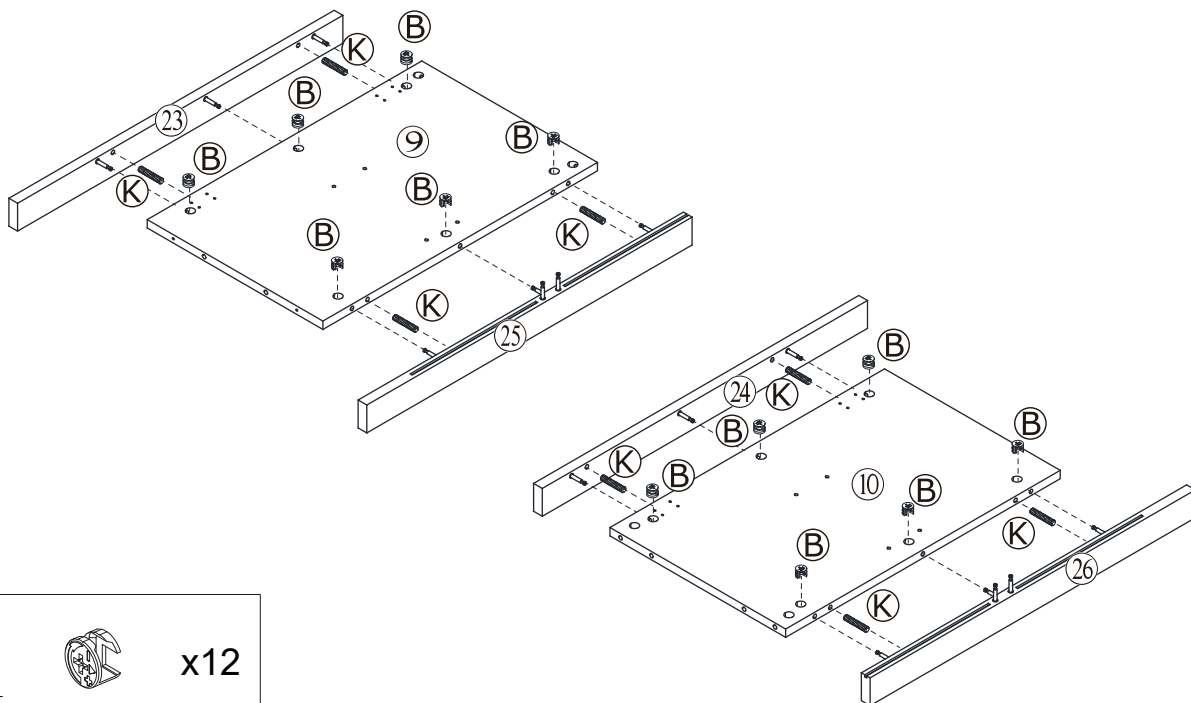

(B)



x12

(K)



x8

Step 12

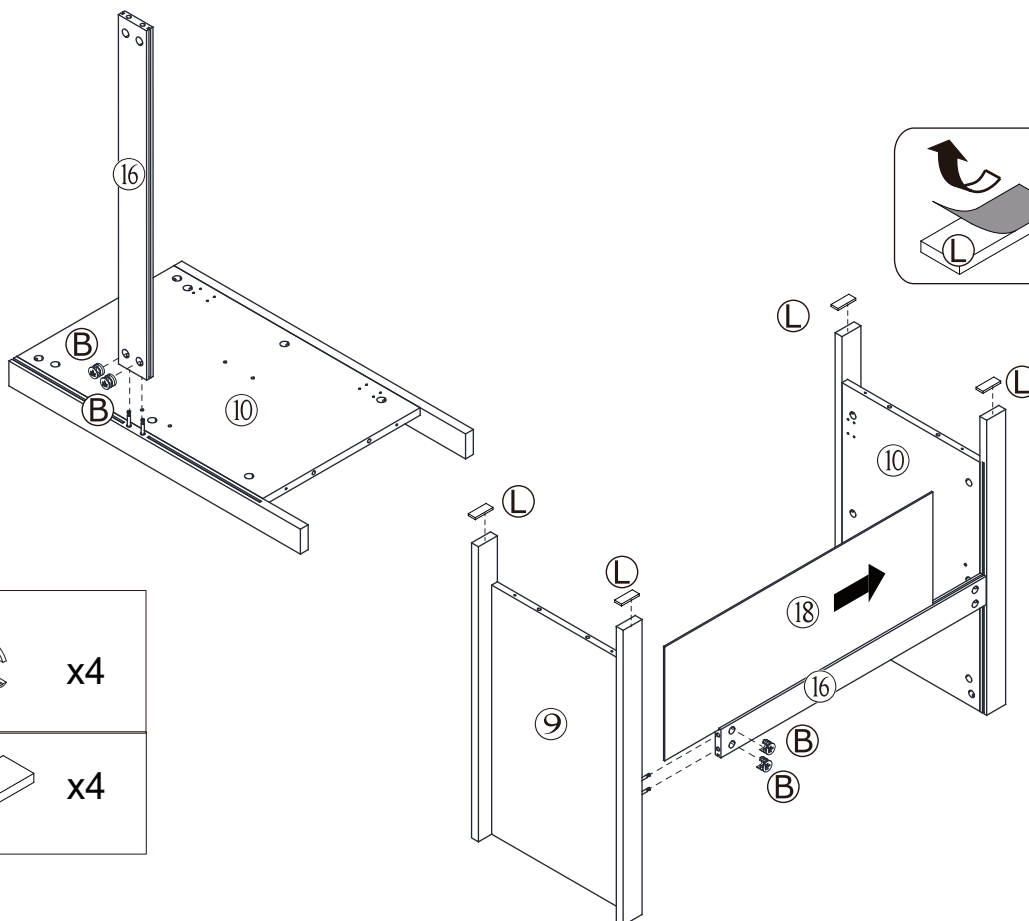

(B)



x4



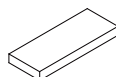

(L)

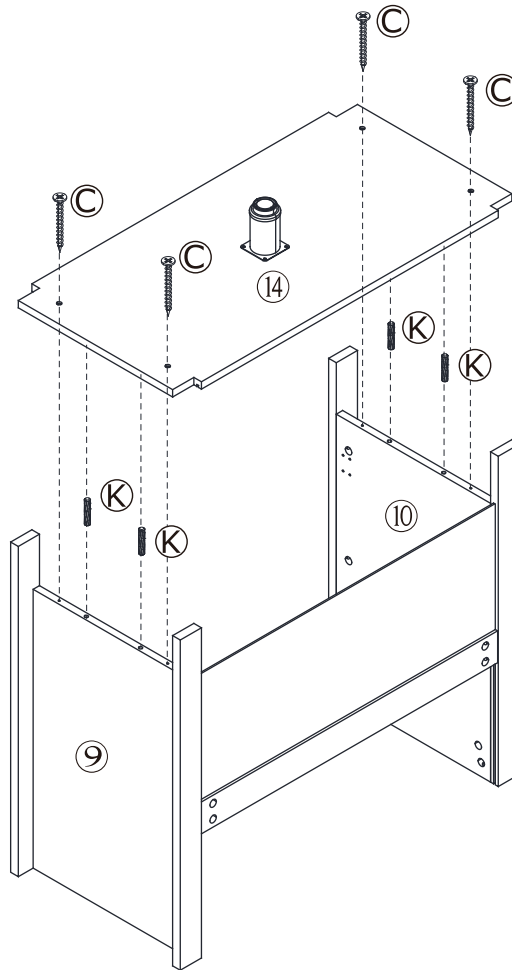
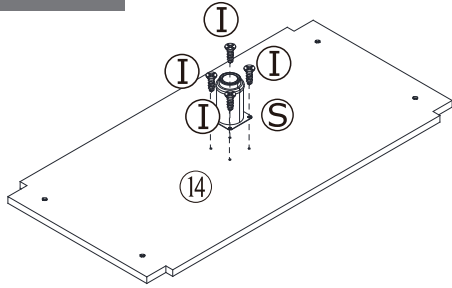

x4

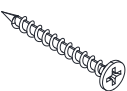
Step 13



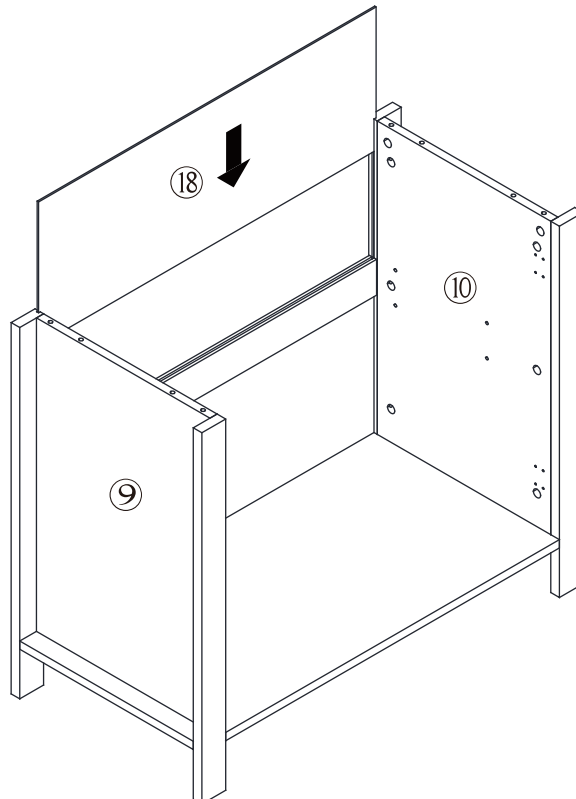

C		x4
K		x4
S		x1
I		x4

Step 14

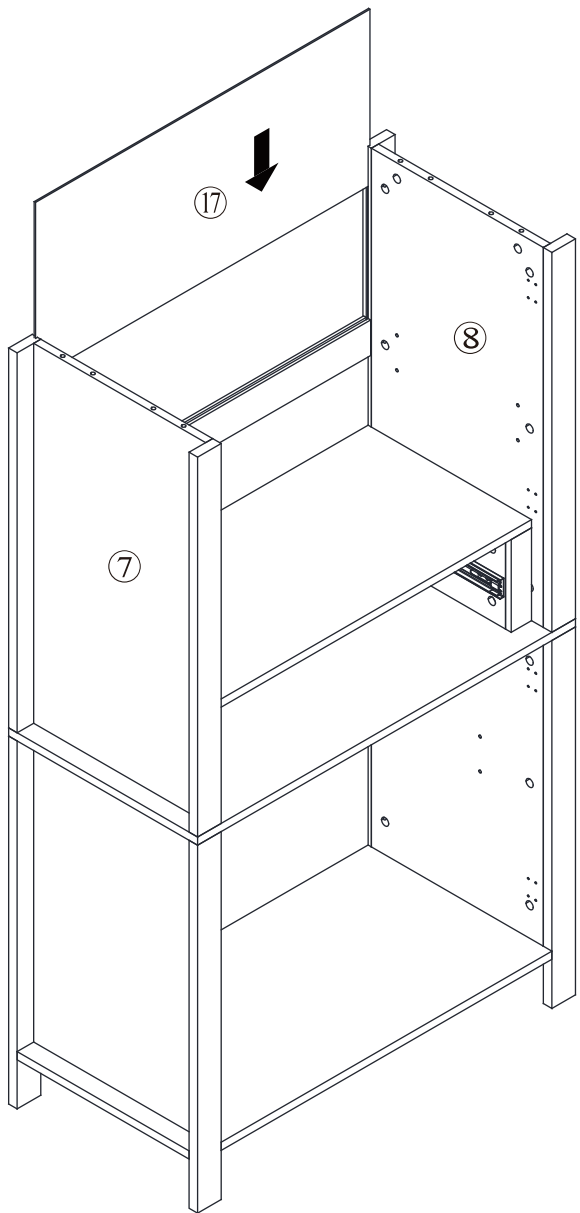
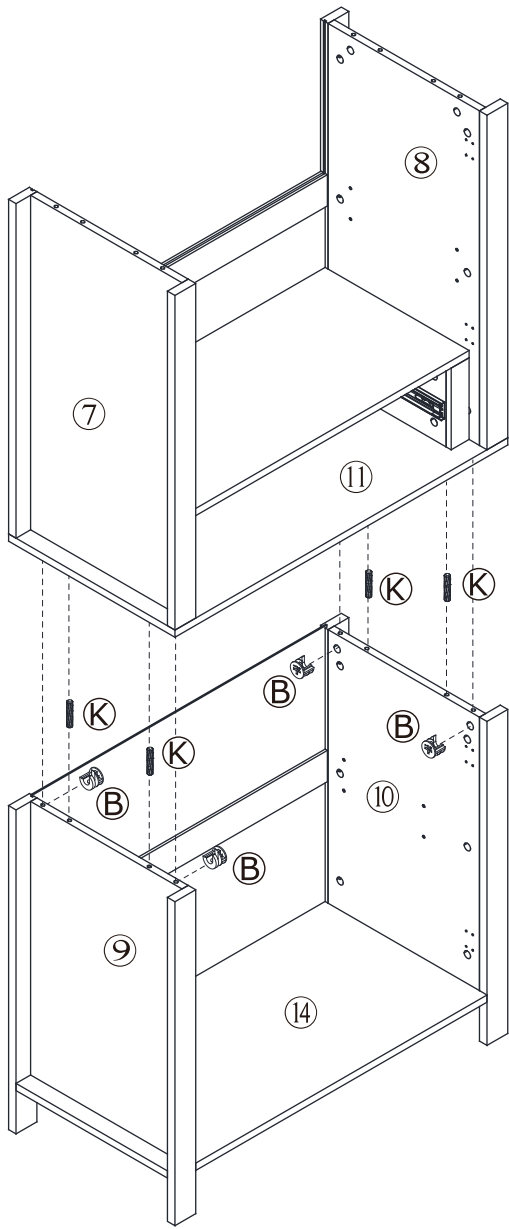

Step 15







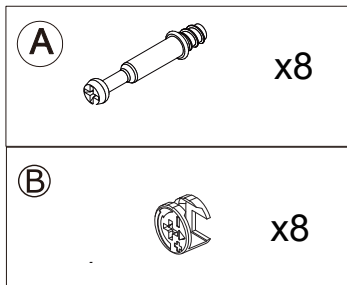
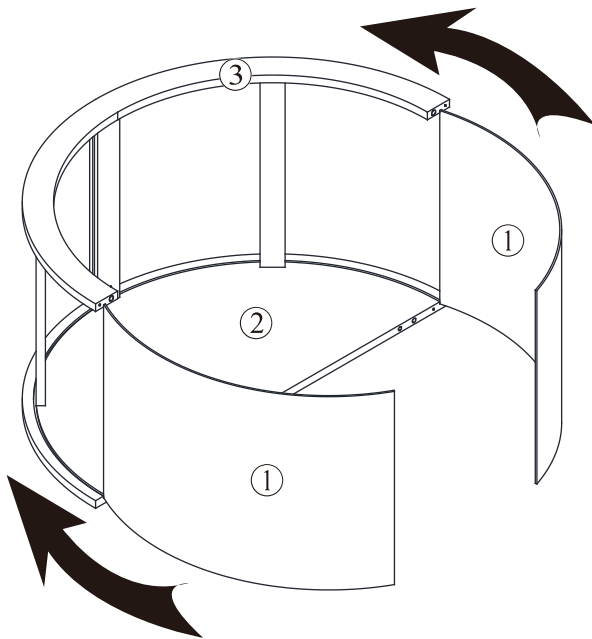
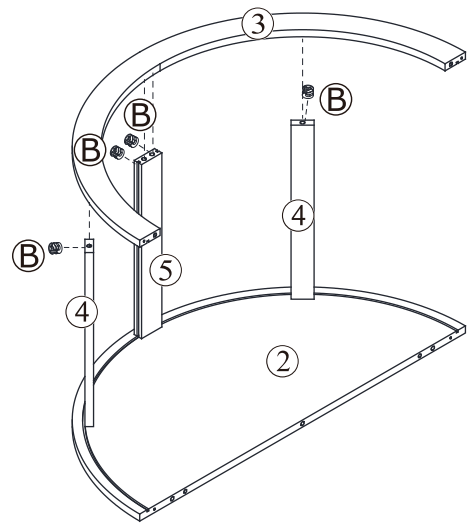
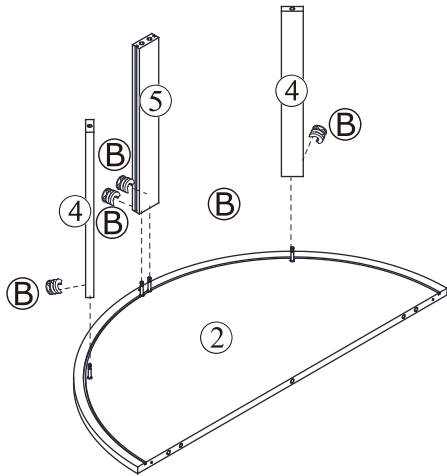
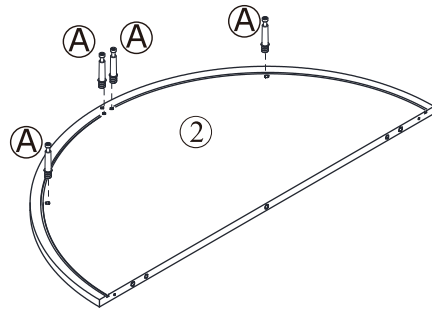
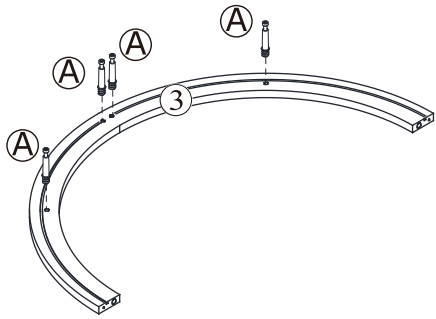

Ⓑ		x4
Ⓚ		x4

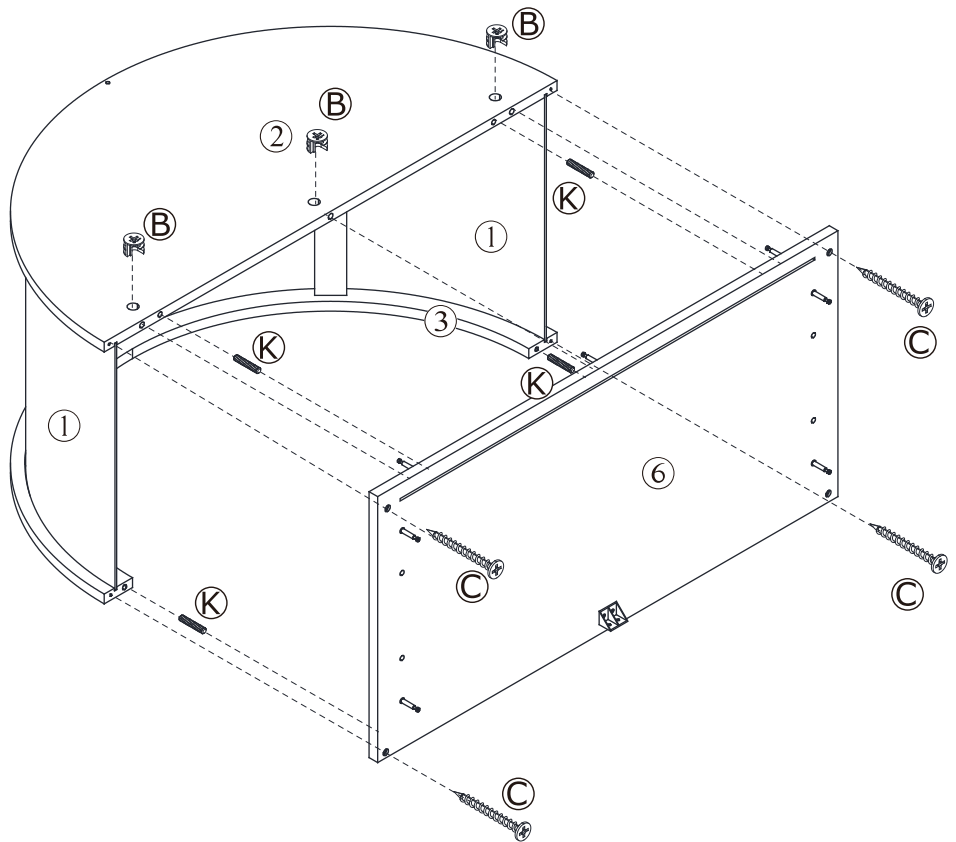
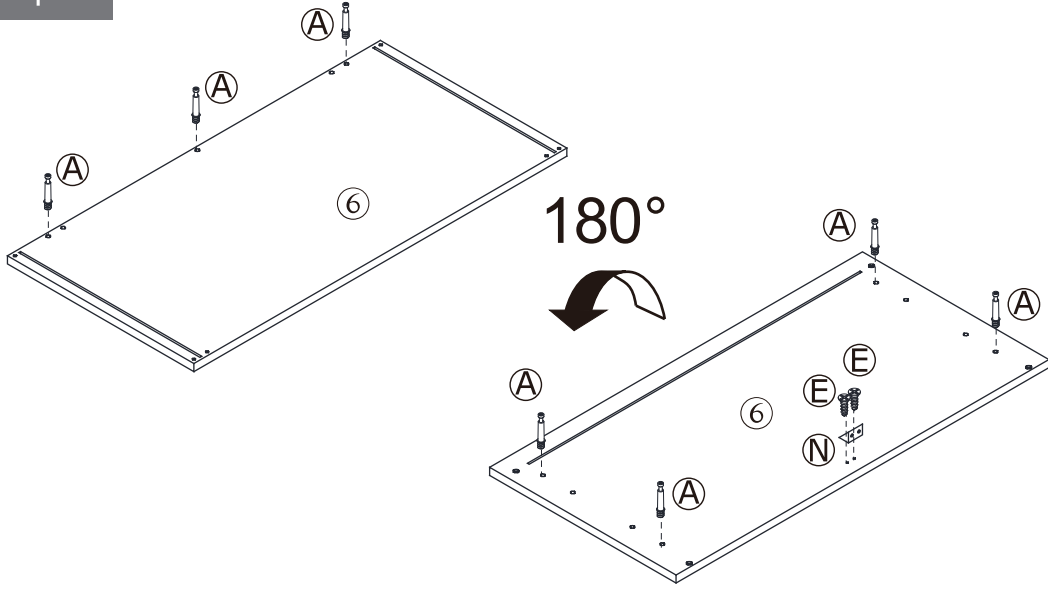
Step 16

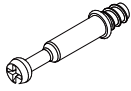

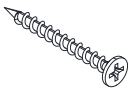
Step 17



(A)		x7
(B)		x3
(C)		x4
(K)		x4
(E)		x2
(N)		x1

Step 18

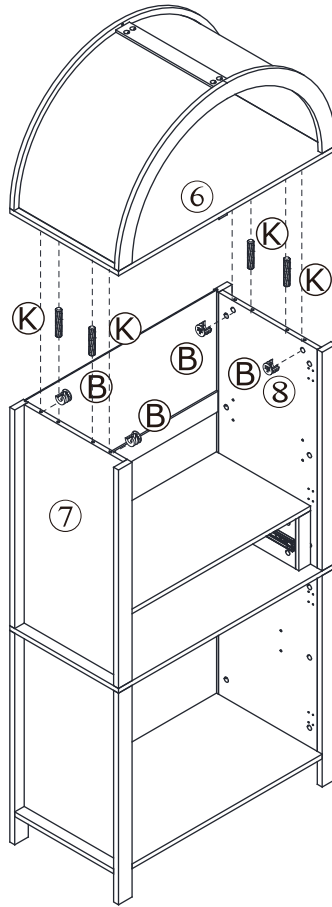

(B)		x4
(K)		x4

Step 19

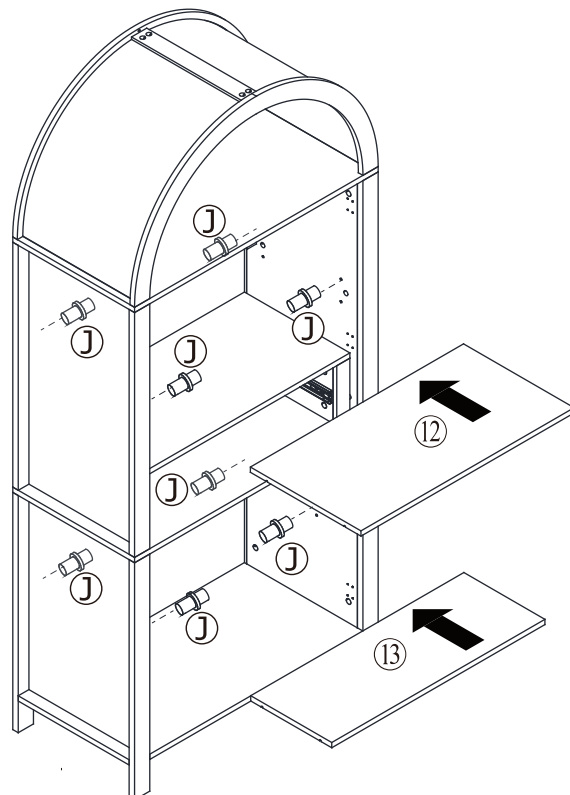

(J)		x8
-----	--	----

Step 20

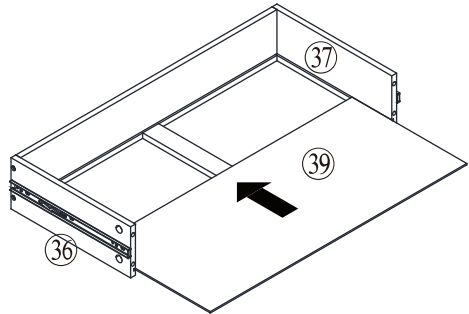
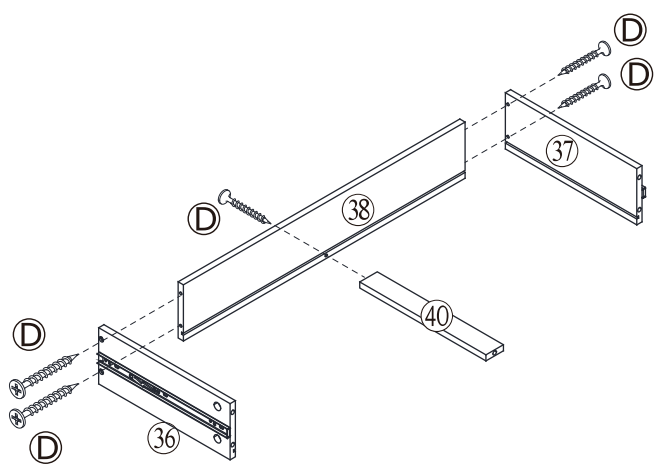
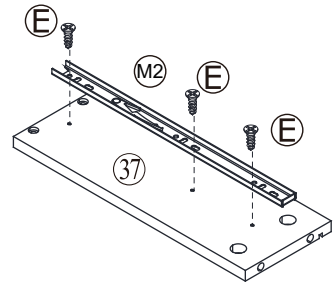
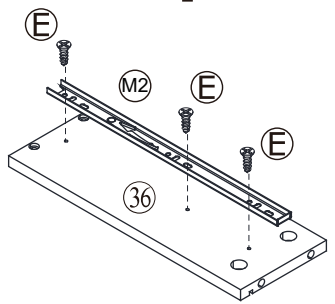
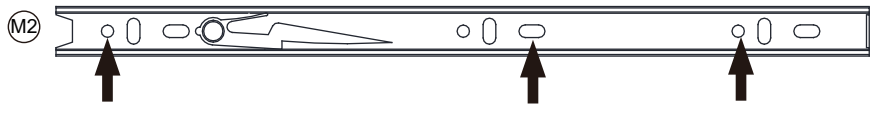

- | | | |
|----------|--|----|
| A | | x5 |
| B | | x5 |
| D | | x5 |
| E | | x6 |
| F | | x2 |
| G | | x2 |
| M | | x2 |

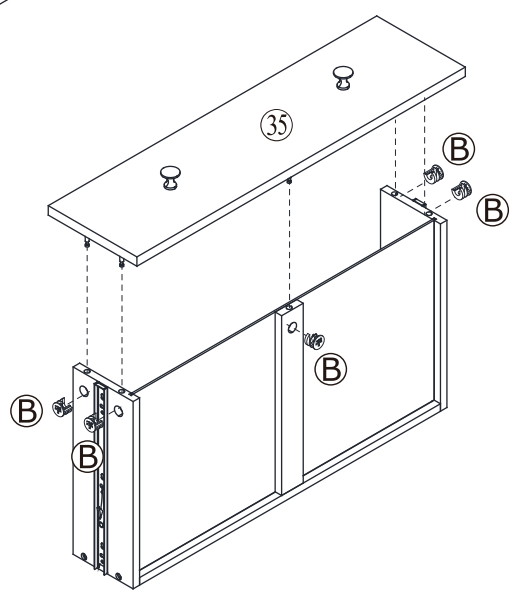
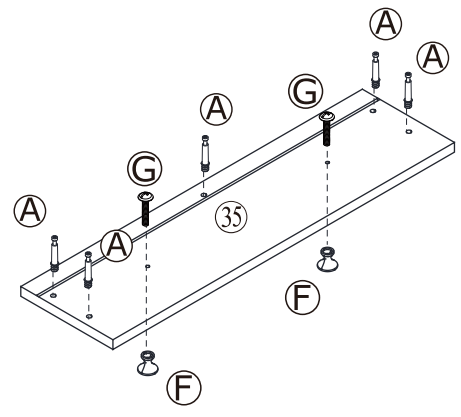

Step 21

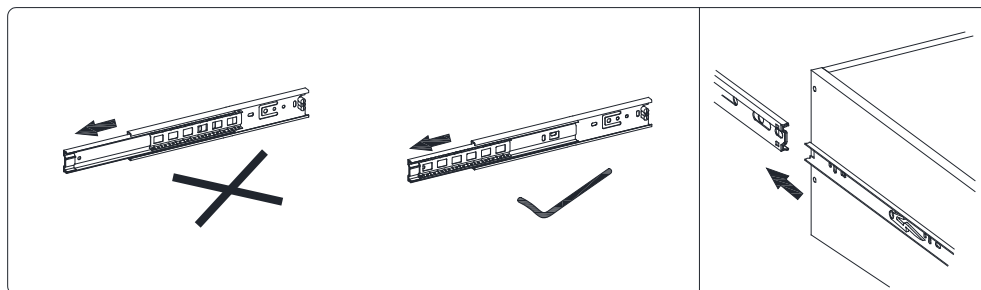
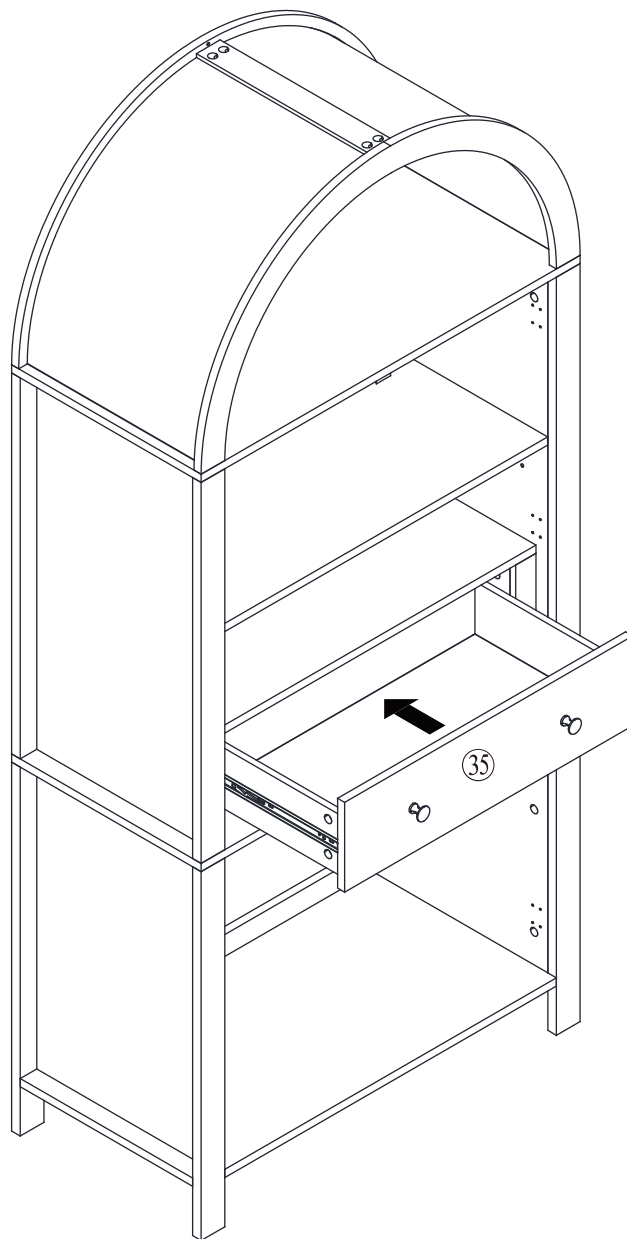



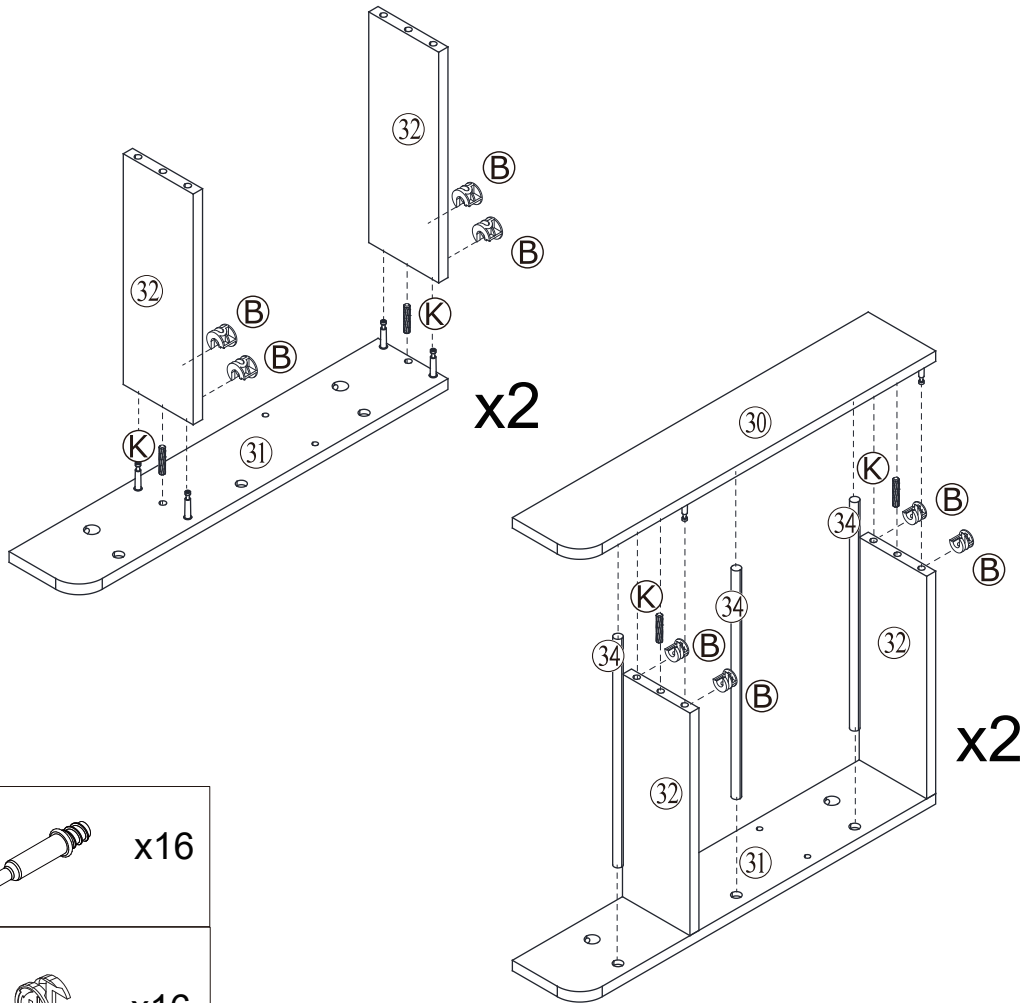
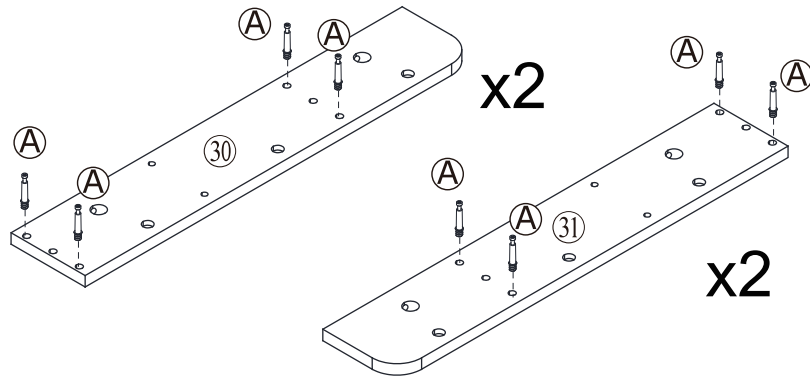

Step 22

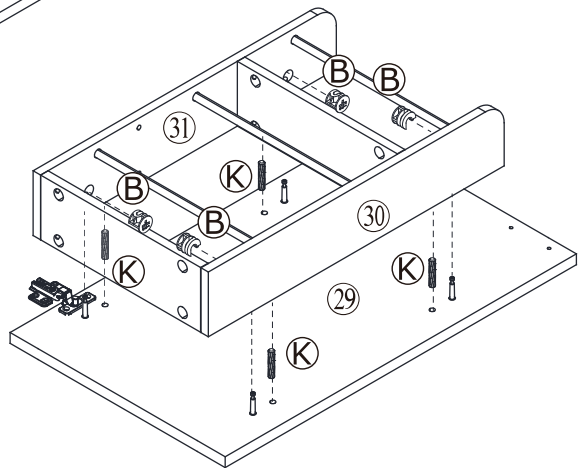
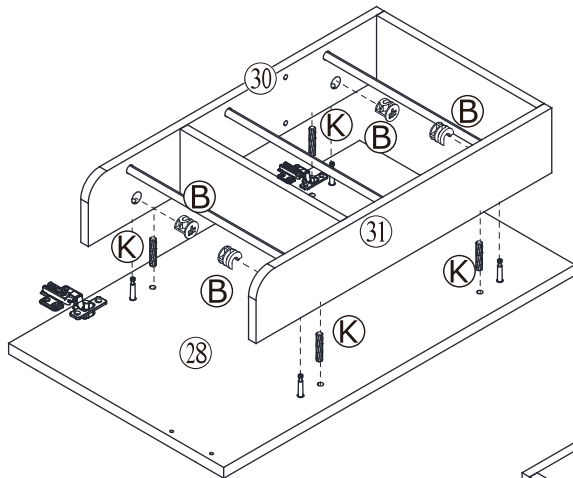
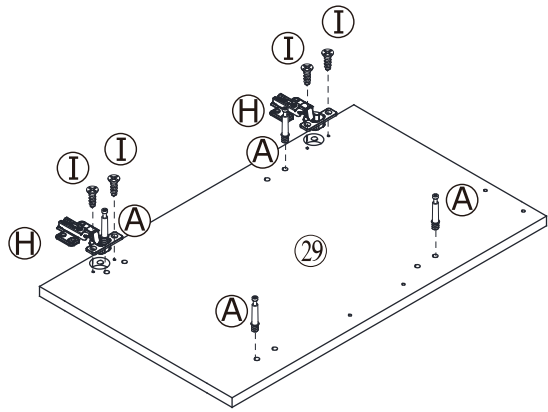
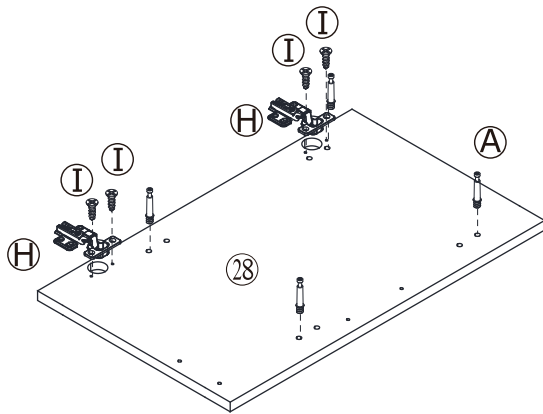

(A)		x16
(B)		x16
(K)		x8

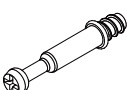
Step 23

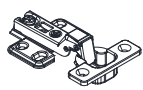



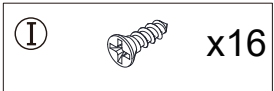
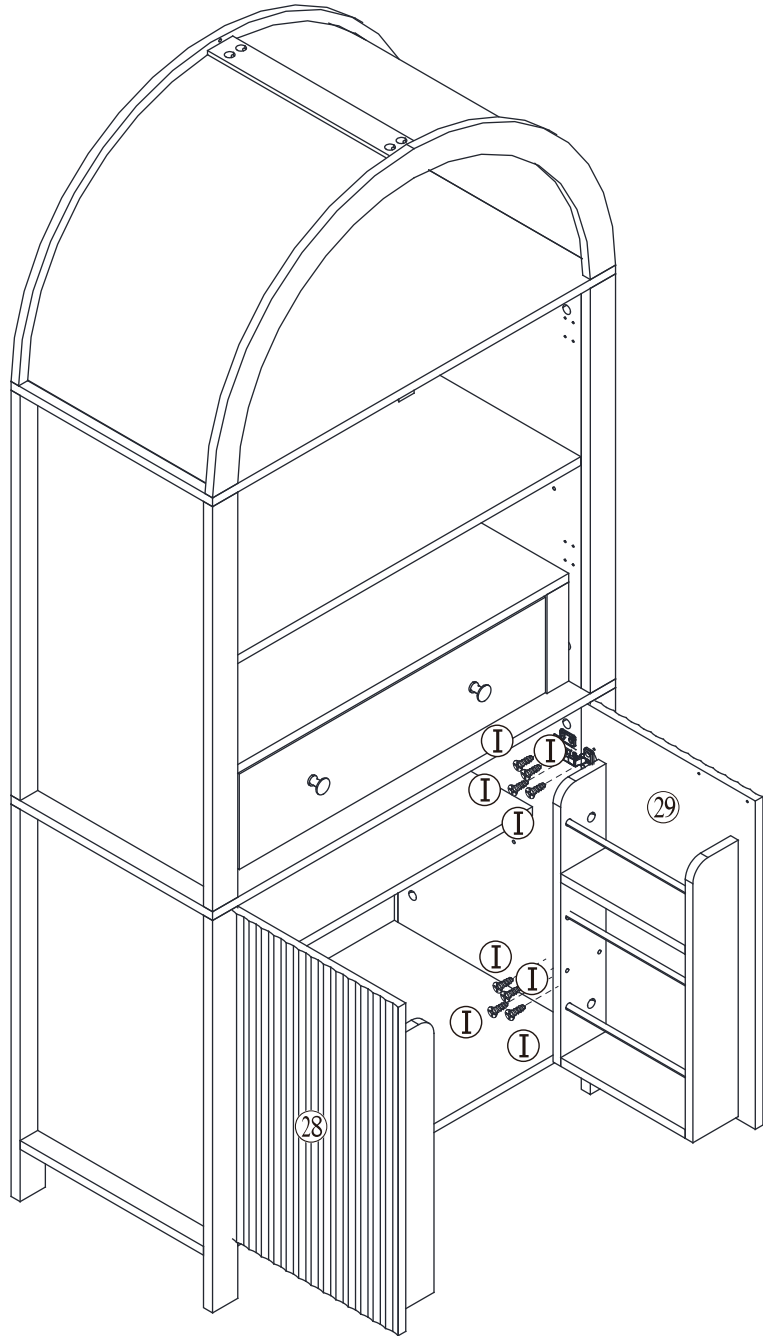
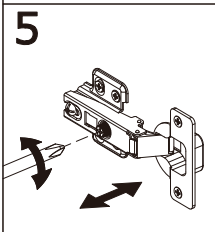
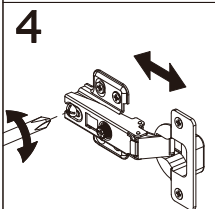
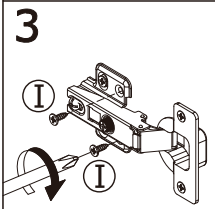
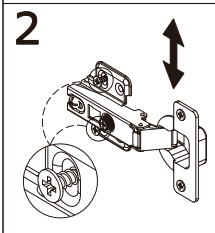
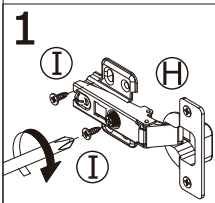

A		x8
B		x8
K		x8
H		x4
I		x8

Step 24

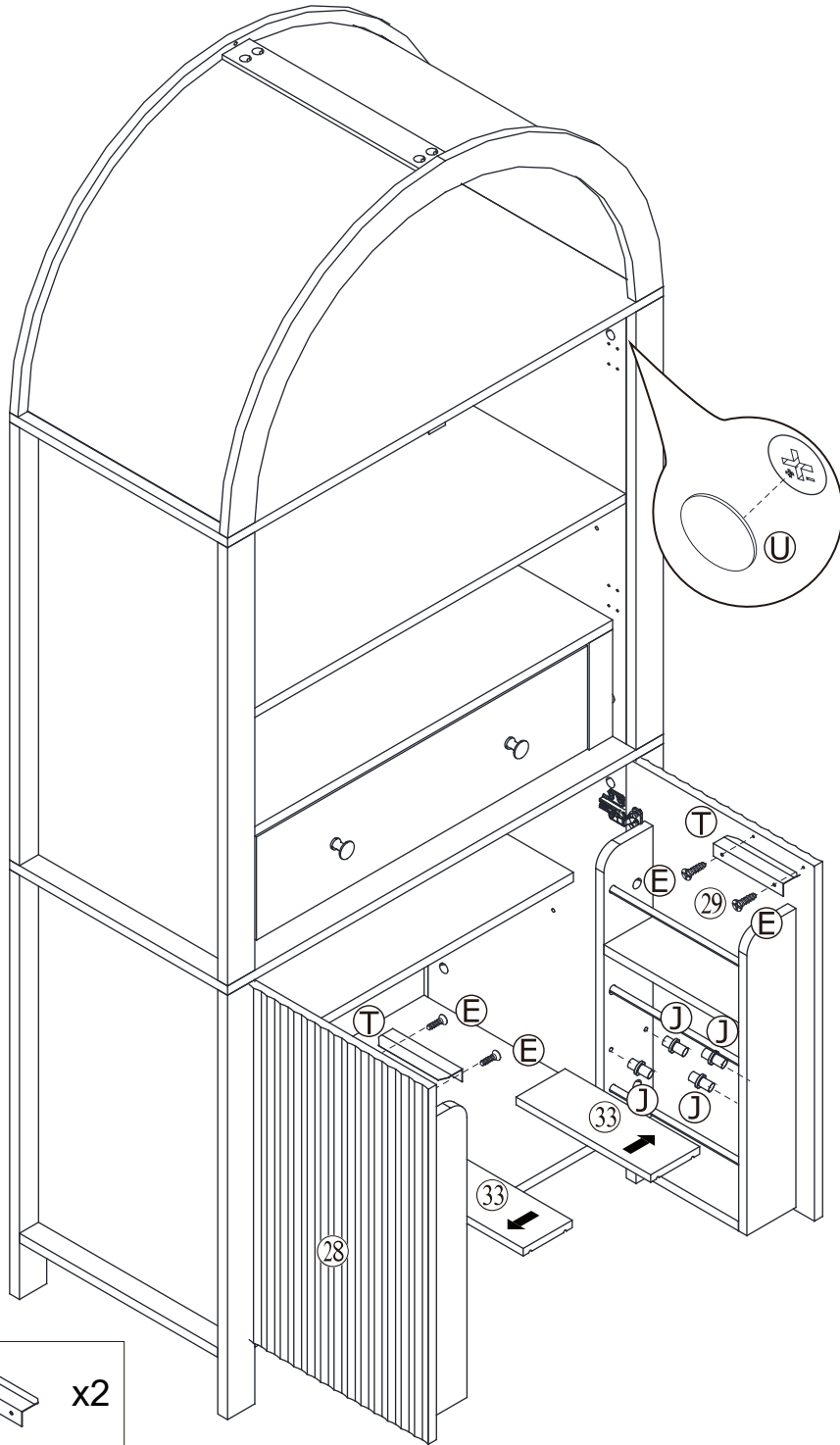

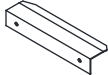
Step 25



Ⓣ		x2
ⓔ		x4
Ⓝ		x8
Ⓤ		x92

Step 26

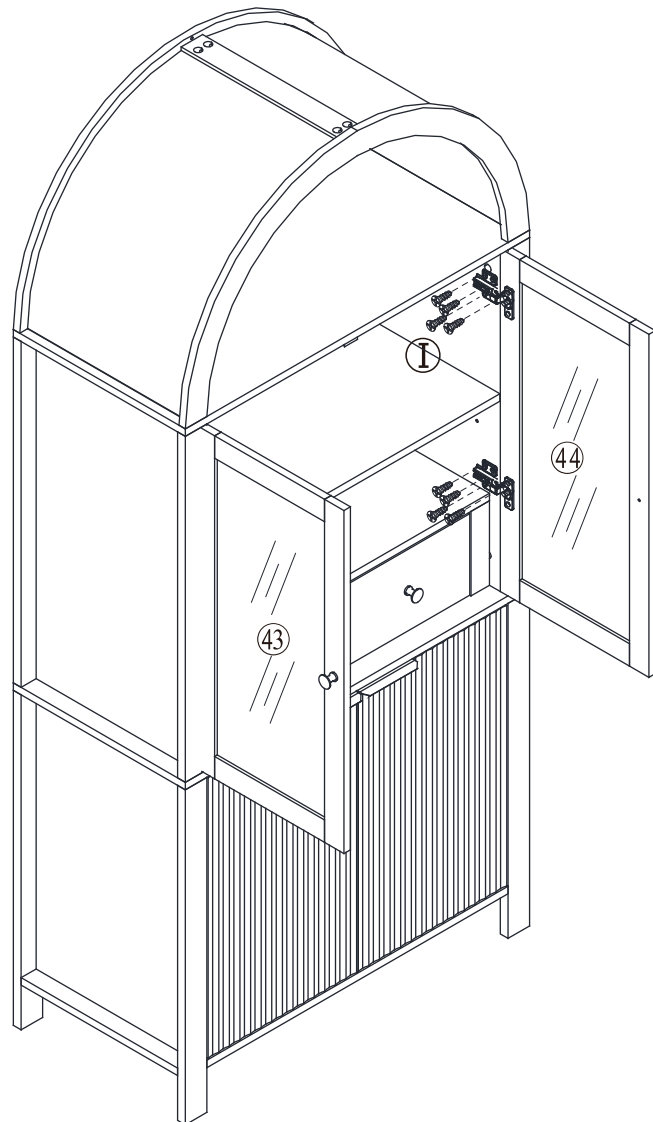
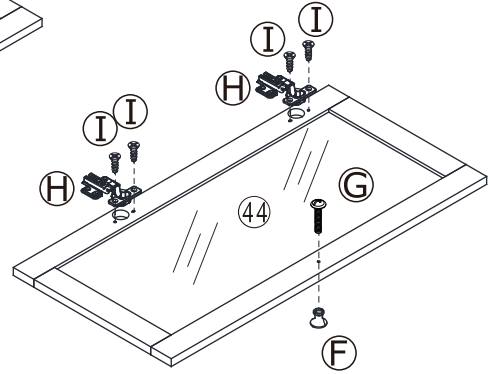
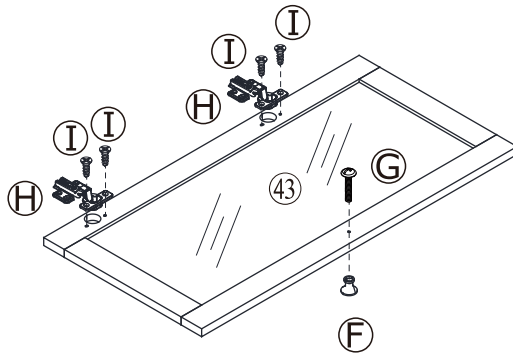
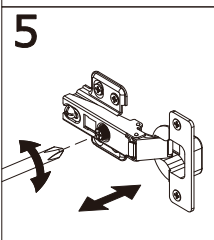
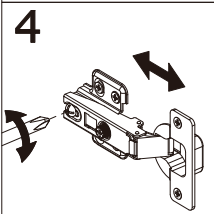
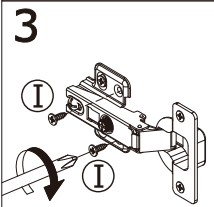
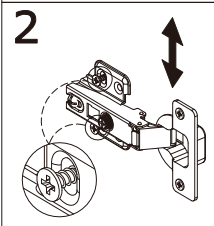
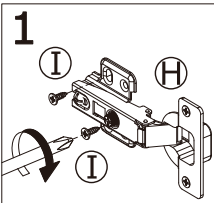

ⓕ  x2



ⓖ  x2

ⓗ  x4

ⓘ  x24

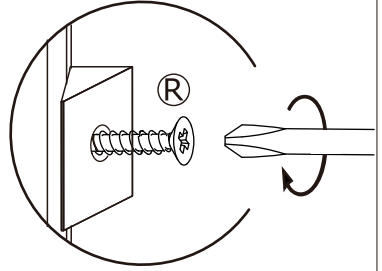
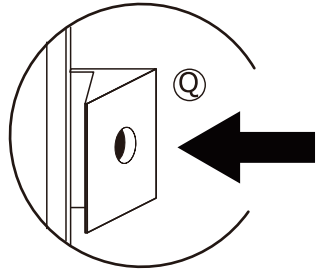
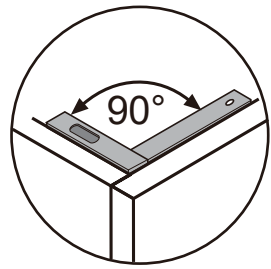
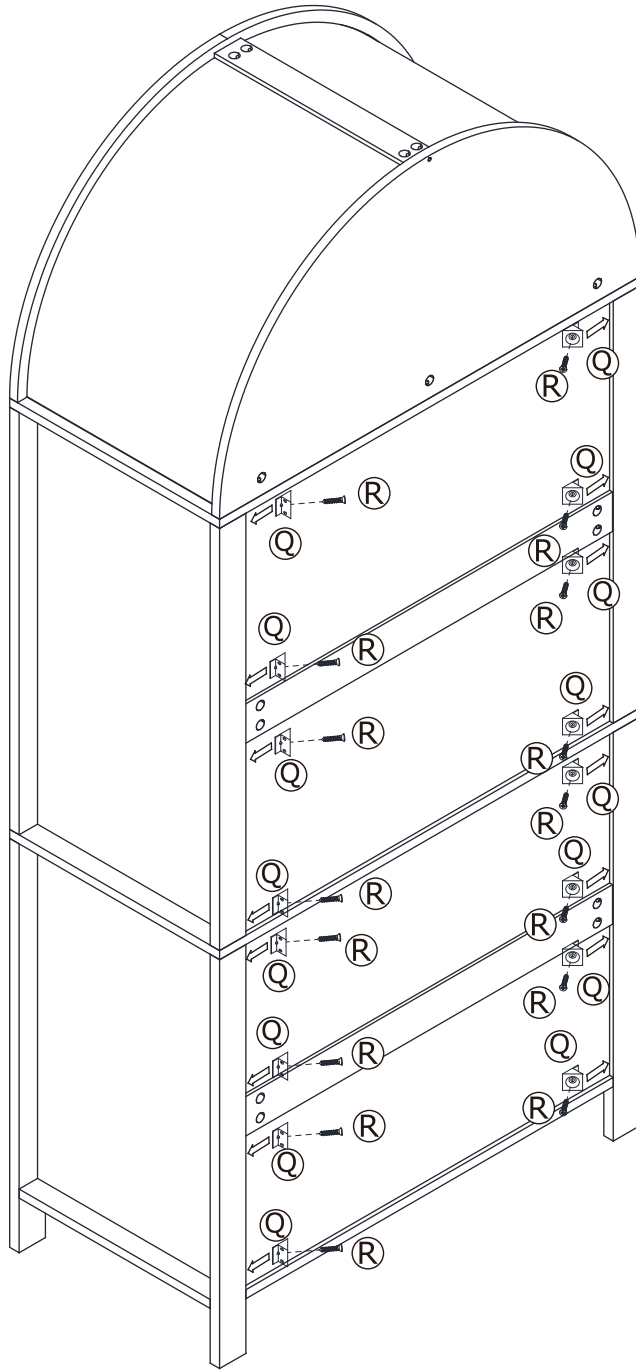

Step 27

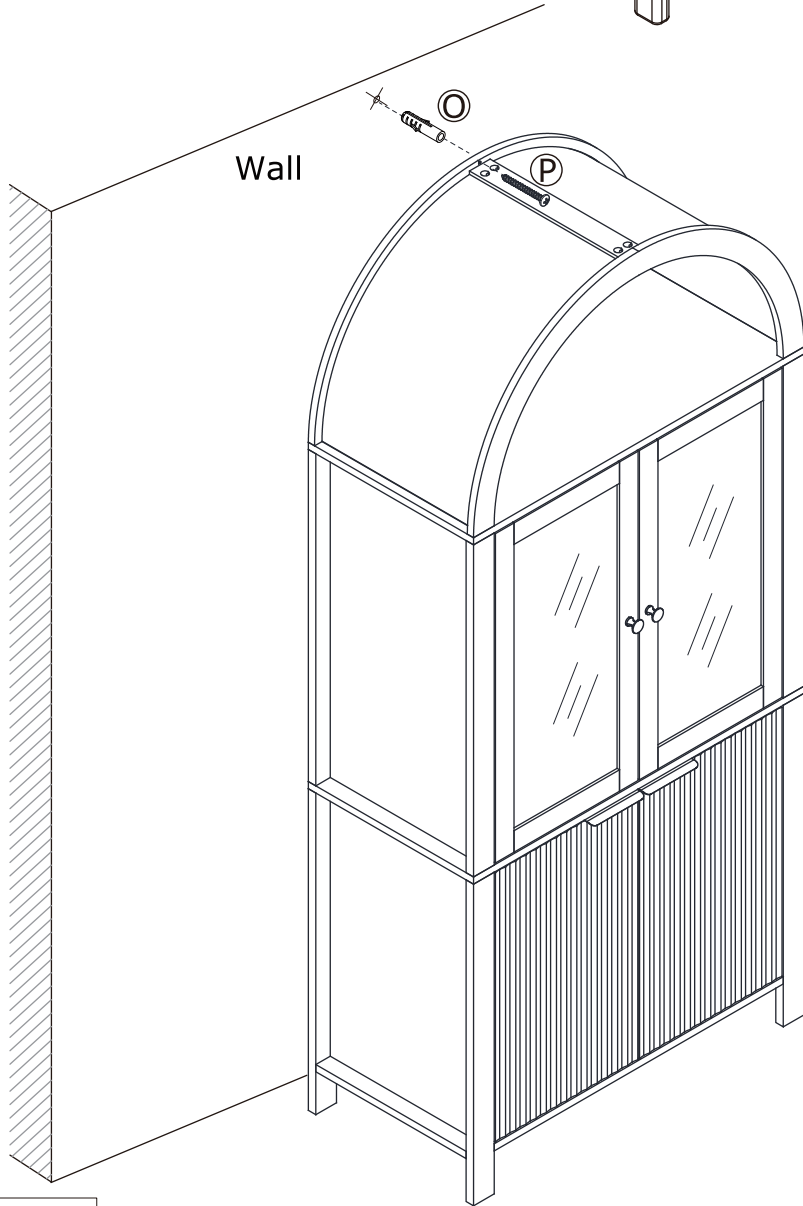
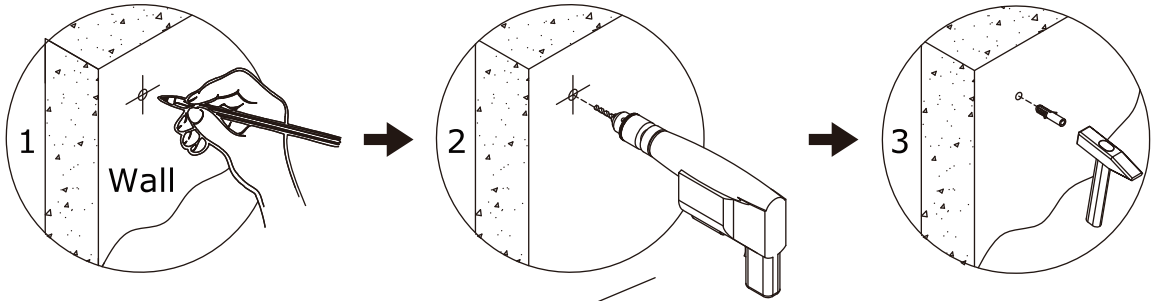

- | | | |
|---|---|-----|
| Q |  | x16 |
| R |  | x16 |

Step 28



- | | | |
|---|---|----|
| ○ |  | x1 |
| Ⓟ |  | x1 |