

Product size: L166.5*W110*H72 cm

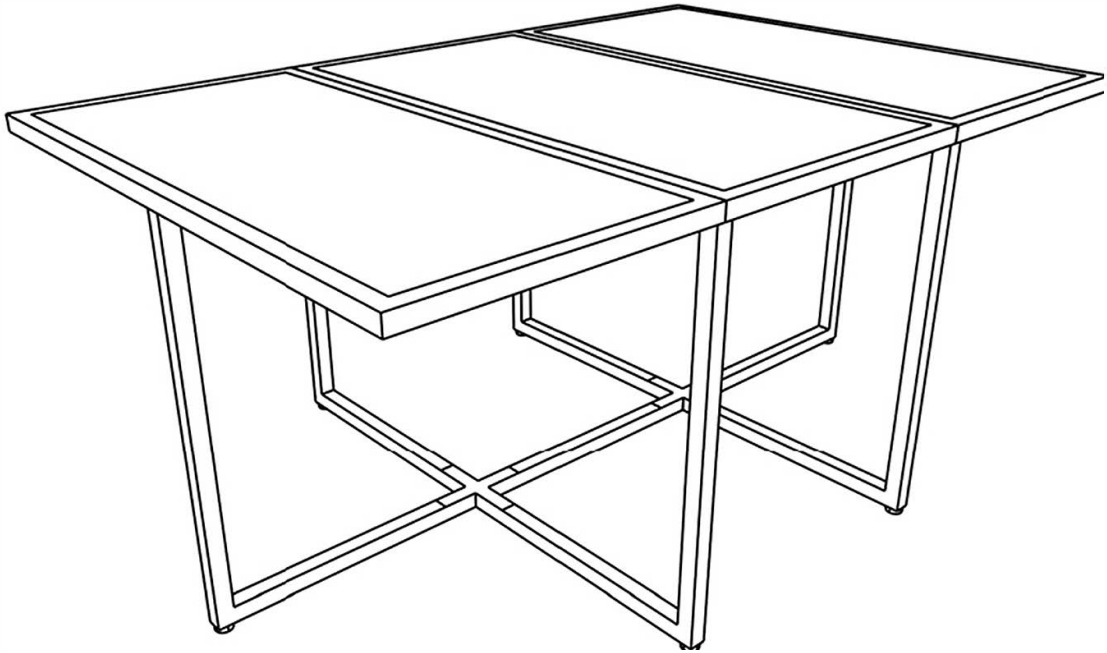

The frame of this product is manufactured from mild steel coated with a weather resistant paint. Steel has a natural tendency to rust over time and, whilst we expect you to be able to enjoy your furniture for many years to come, we recommend that you check the product from time to time for signs of paint damage and/ or rust. If the paint should become damaged, or if rust begins to form, you should clean the affected area and apply a suitable "thinners based" touch-up paint. Such paints are readily available from all good hardware and DIY stores.

The intended use of this product is for domestic use only.

Important, please retain for future reference.

Read carefully.

Before you start



Warnings

IMPORTANT, RETAIN FOR FUTURE REFERENCE READ CAREFULLY

See enclosed instructions for assembly, safety and care information.

Failure to follow the warnings could result in serious injury.

Handle heavy parts with care.

Ensure that this product is fully assembled as illustrated before use.

This product should only be used on firm, level ground.

Keep small parts out of reach of children.

Do not stand or climb onto this product.

This product is intended for **domestic use** only.
Ensure the table is always placed on level ground.

Furniture can be dangerous if incorrectly used. No liability will be accepted for damage or injury caused by incorrect use of this product.



Dos

When you are ready to start, make sure that you have the right tools, plenty of space and a clean, dry area for assembly.

Unwrap all packaging materials and place the components on suitable surface to prevent scratching your product.

Check the pack and make sure you have all of the parts listed. In the event of problems or missing parts, please contact the seller.

Check all screws and bolts are tightened and inspect regularly.

This product is suitable for all year outdoor use, but we recommend that a furniture cover be used to add additional protection to your product when not in use.

During server weather conditions, including high winds, rain, hail, thunderstorms, extreme heat and cold temperatures, the product should be stored inside in a cool, dry place.

During prolonged sunny spells, we recommend that furniture should be covered over with a protective furniture cover and/or stored inside when not in use. This will help prevent harmful UV rays from damaging and discolouring the material.

To best preserve the material (synthetic rattan) we recommend the use of a UV protector spray like Fabsil. This will block the harmful UV rays from damaging the material.

Before storage, ensure that the product is clean and dry.

To clean, wipe down with a sponge and warm soapy water and wipe with a clean, dry cloth.

When cleaning glass panels use a damp cloth or leather with washing up liquid or soft soap if necessary; do not use washing powders or any other substances containing abrasives since these substances scratch glass.

X Don'ts

Do not stand or climb onto the product.

Do not use power tools to construct this product.
Do not sit or lean onto the rims of this product.

Do not use this product if parts are missing, damaged or worn.

Never use scourers, abrasives or chemical cleaner.

Do not use this table as a ladder as this could lead to the table becoming unbalanced and overturning.

Do not place very hot or very cold items on the glass surface unless adequately thick table-mats are used to prevent such items from coming into contact with the glass.

Do not use the glass as a chopping surface. Do not strike glass with hard or pointed items.

Never drag furniture when moving it, always lift it.

Number of people required for assembly

Two people

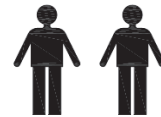

Time to assemble

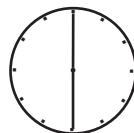

30 Minutes

Tools required

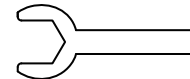





Tips:

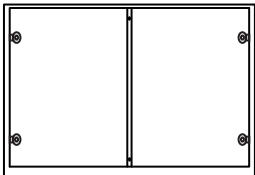
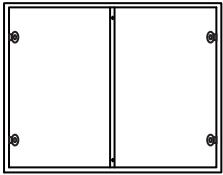

It is best not to fully tighten the nuts and bolts until they are all correctly located. Only carefully tighten them when you are satisfied with the alignment of all components.

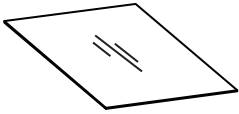
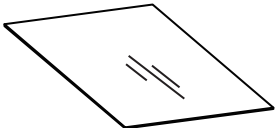
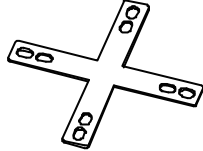
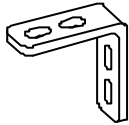
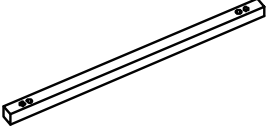
Be careful not to overtighten.

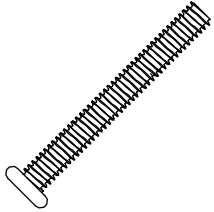
Components, fixtures & fittings (not actual size)

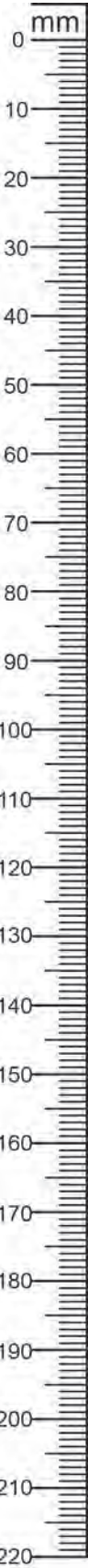
Parts List					
Part No.	Diagram	Qty.	Part No.	Diagram	Qty.
A	 Table Top Frame(Side)	2 PCS	B	 Table Top Frame(Middle)	1 PC
C	 Table Leg	6 PCS	D	 1033*498mm Glass Top (Side)	2 PCS
E	 1033*524mm Glass Top(Middle)	1 PC	F	 Connecting Panel	2 PCS
G	 L-Shape Connecting Bar	12 PCS	H	 Connecting Bar	1 PC
N15	 M6*15mm Bolt	64 PCS	N45	 M6*45mm Bolt	8 PCS

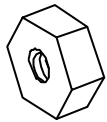

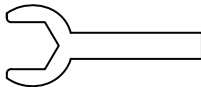
F2	 Nut	8 PCS	F3	 Washer	80 PCS
AK	 Allen Key	1 PC	S1	 Spanner	1 PC

Step by step assembly instructions

Step One

With the help of another person, attach the Connecting Panel (F) to the Table Legs (C) and Connecting Bar (H) using Washers (F3) and Bolts (N15).

At this stage, please do not tighten all Bolts, just let it can be rotated freely.

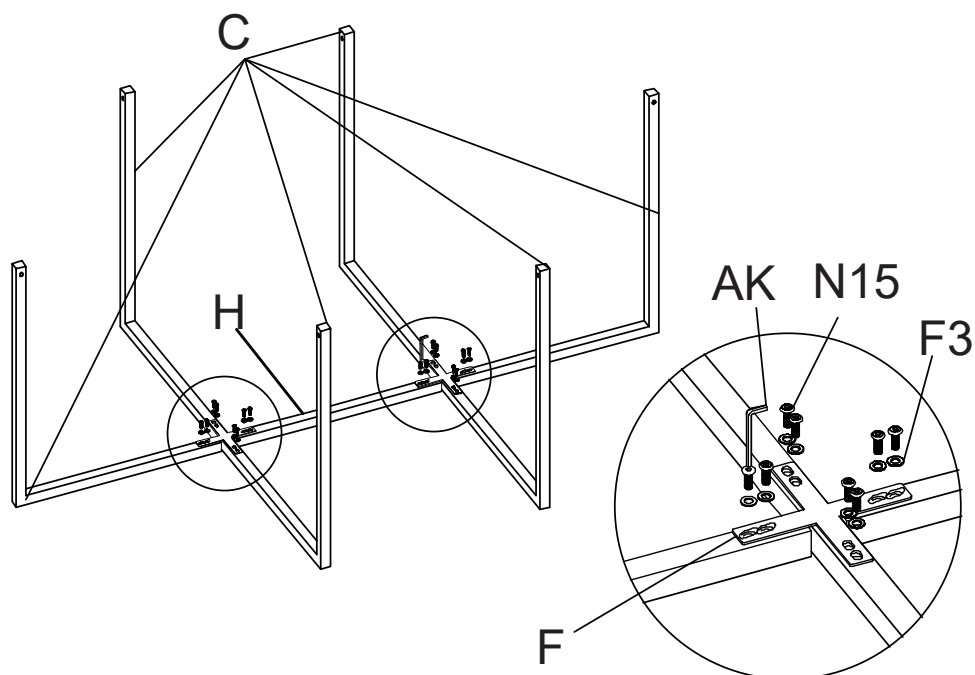

Step Two

With the help of another person, combine the Table Top Frame(Side) (A) and Table Top Frame(Middle) (B) using Washers (F3) , Bolts (N45) and Nuts (F2).
At this stage, please do not fully tighten all Bolts and Nuts.

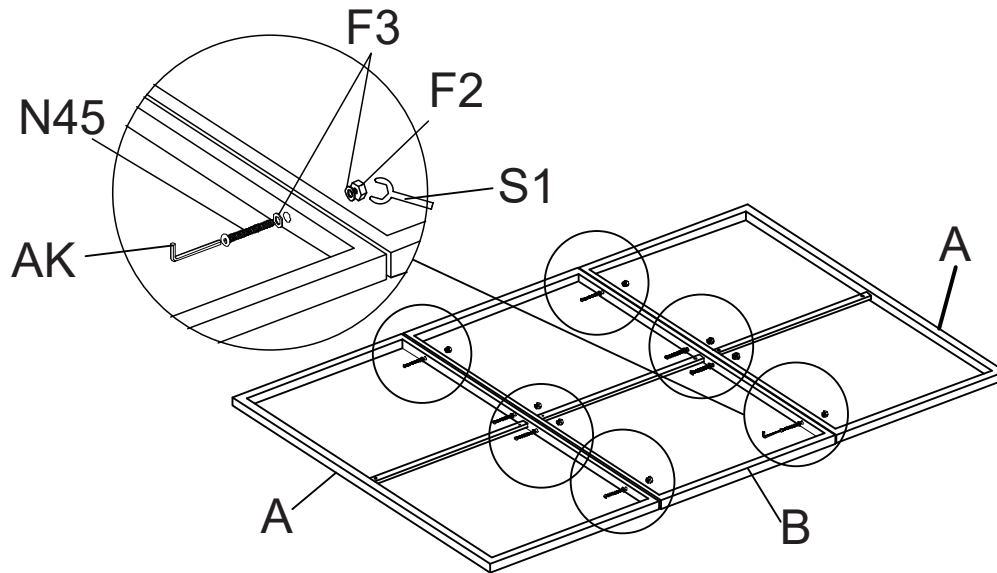

Step Three

With the help of another person, attach the Table Top Frame(Side) (A) and Table Top Frame(Middle) (B) to the Table Legs (C) using L-Shape Connecting Bar (G), Washers (F3) and Bolts (N15).

Once you are satisfied with the alignment of all components, carefully tighten all Bolts and Nuts using Allen Key (AK) and Spanner (S1).

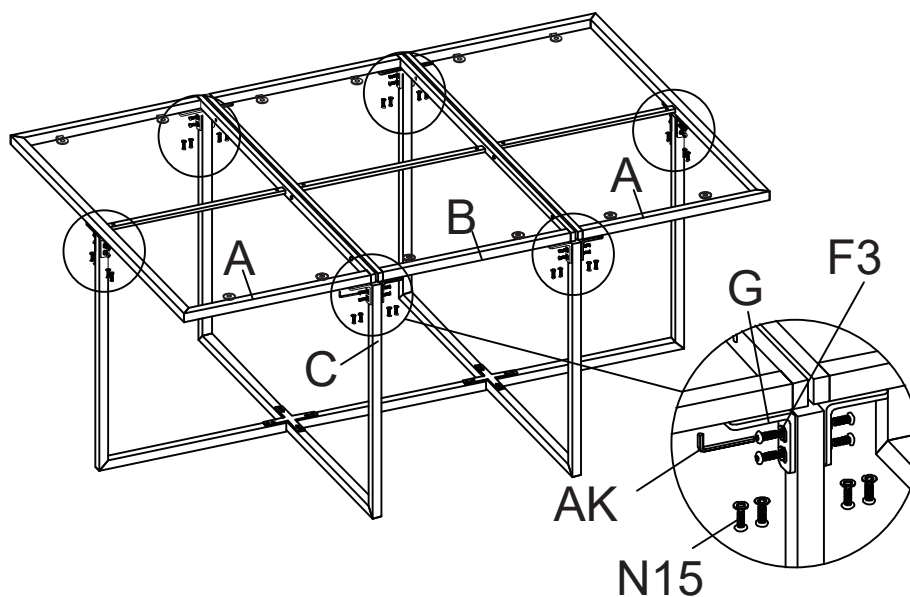

Step Four

With the help of another person, carefully lift and place Glass Top (Side) (D) and Glass Top (Middle) (E) onto the Table Top Frames.

Make sure the glass top rest evenly and securely within the table frame.
Level the table by adjustable feet screw.

Your table is now ready for use.

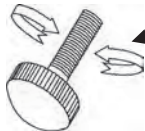
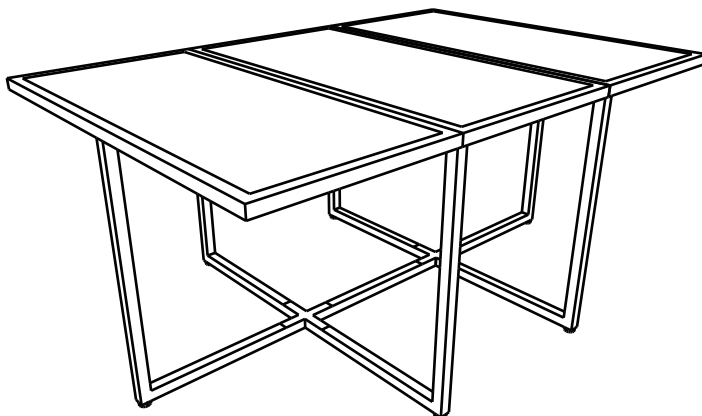
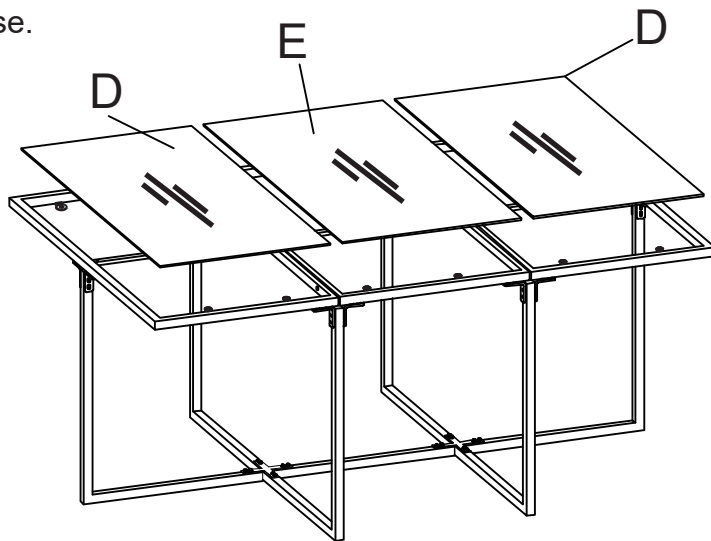

Adjustable Foot Screw

PLEASE KEEP THESE INSTRUCTIONS FOR FUTURE REFERENCE