







WINSTON®

Assembly instructions for M69042R-HST, M69042R-BST

| KD Table Parts | | |
|---|-------------|-----|
| Image | Description | Qty |
|  | Table Leg | 4 |
|  | Center Ring | 2 |
|  | Table Top | 1 |

| Hardware | | |
|---|------------------------------|-----|
| Image | Description | Qty |
|  | 1/4-20 X 1 1/2" Hex Bolt | 8 |
|  | 5/16 X 1 3/4 Ss Wshr Hh Bolt | 8 |
|  | Lock washer 5/16" | 8 |

General Instructions

1. Separate and identify all parts, ensuring that all listed components are present.
2. To avoid scratches during assembly, use a soft surface or a cardboard box as a work area.
3. Follow the step-by-step instructions carefully.
4. Do not tighten bolts until all bolts and washers are properly installed.
5. Tighten bolts securely, but do not overtighten.

Step 1

- Attach legs to the center rings using 5/16" x 1 3/4" bolts and 5/16" lock washers. **Do not tighten yet.**

Step 2

- Place the tabletop on a flat/soft surface. Position the pre-assembled base legs over the tabletop, aligning the leg holes to the holes in the tabletop.

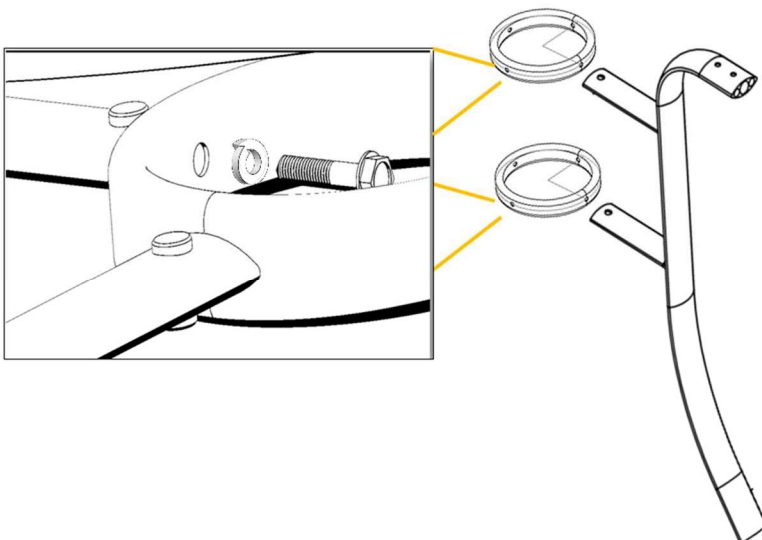

Step 1

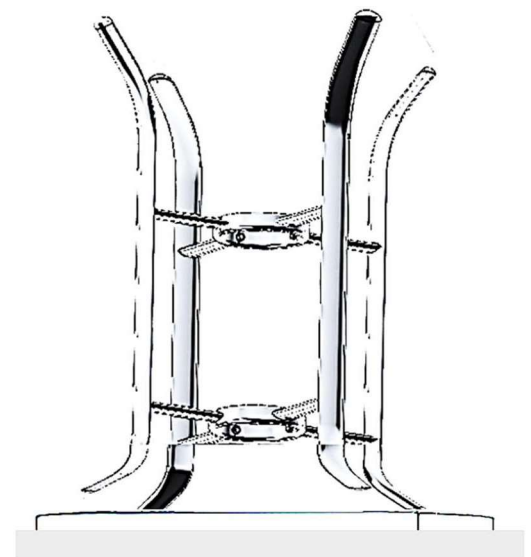

Step 2

WINSTON®

Assembly instructions for M69042R-HST, M69042R-BST

Step 3

- Attach and secure pre-assembled base legs to the tabletop using 1/4" X 1 1/2" Hex bolts, tighten all these bolts before next step.

Step 4

- Flip the table into an upright position on a flat surface, adjust or align the legs if needed to level, and then tighten the center ring bolts and washers to complete the assembly.

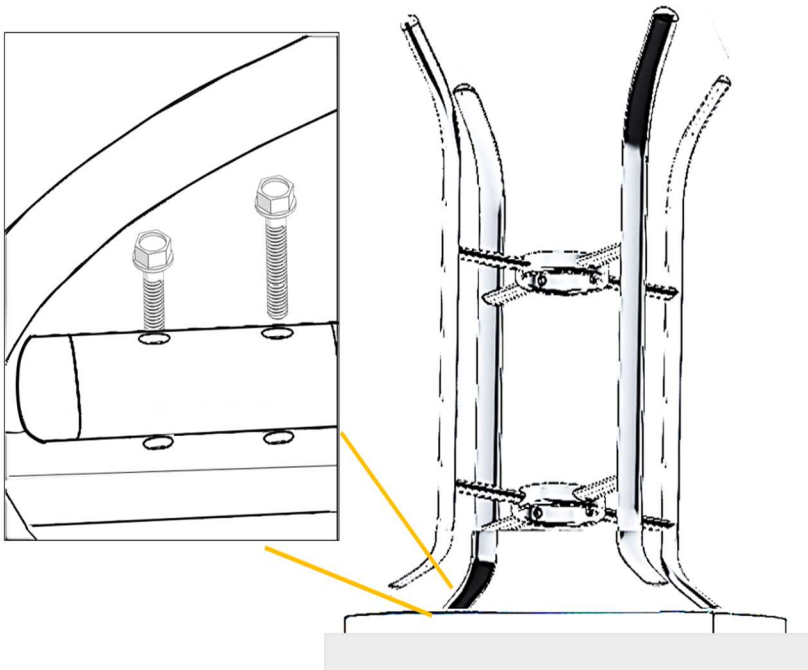

Step 3



Step 4

Notes:

- Do not allow children to play with plastic wrapping or small parts, as these could be potential choking hazards. Discard immediately.
- Do not stand or climb on this KD Table
- Periodically check and ensure that all the bolts are completely tightened