

ASSEMBLY INSTRUCTION FOR SIDE TABLE

PARTS INCLUDED

Table Top 1 pc.

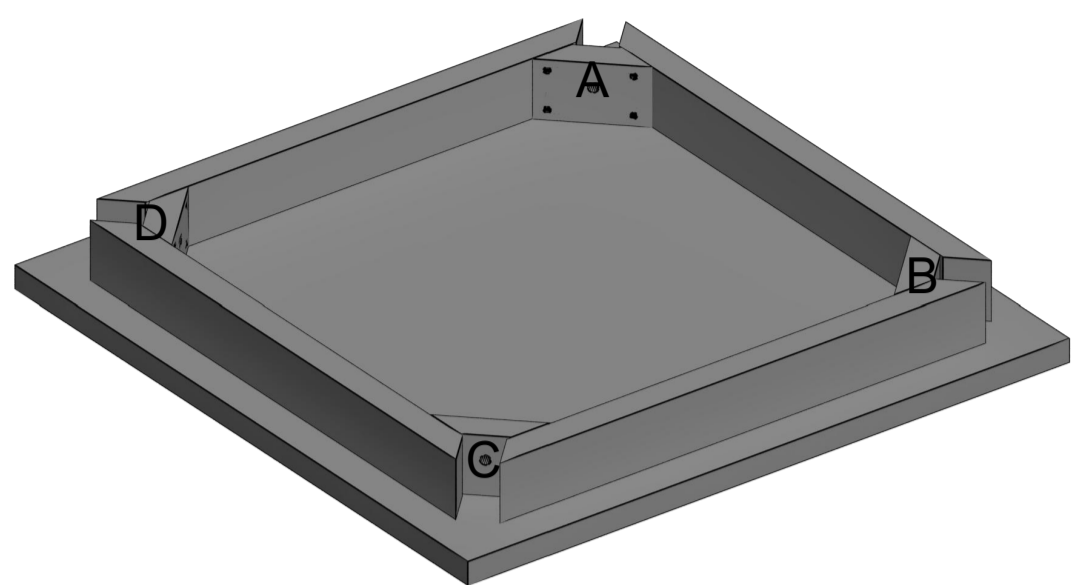

(Fig. 1)

Legs 2 pcs.

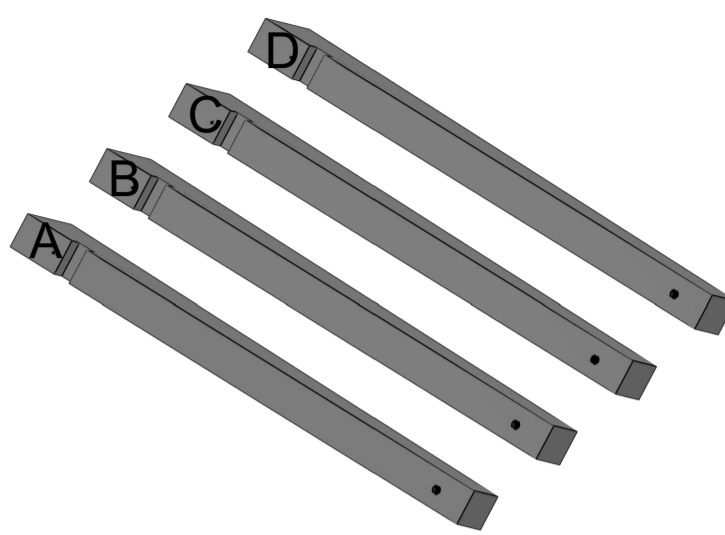

Bottom Plate 1 Pc.

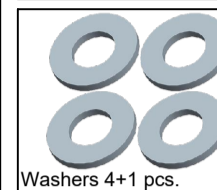
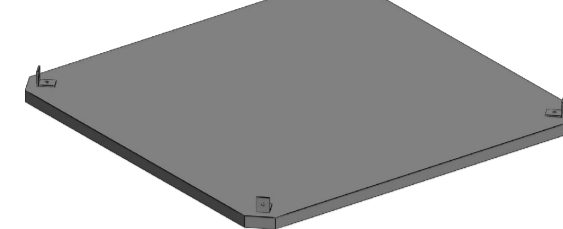

Washers 4+1 pcs.



Allen Bolts(L) 4+1 Pcs.

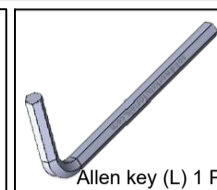

Allen key (L) 1 Pc.



Allen Bolts(S) 4+1 Pcs.

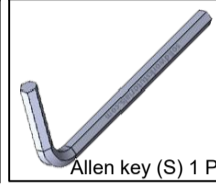

Allen key (S) 1 Pc.

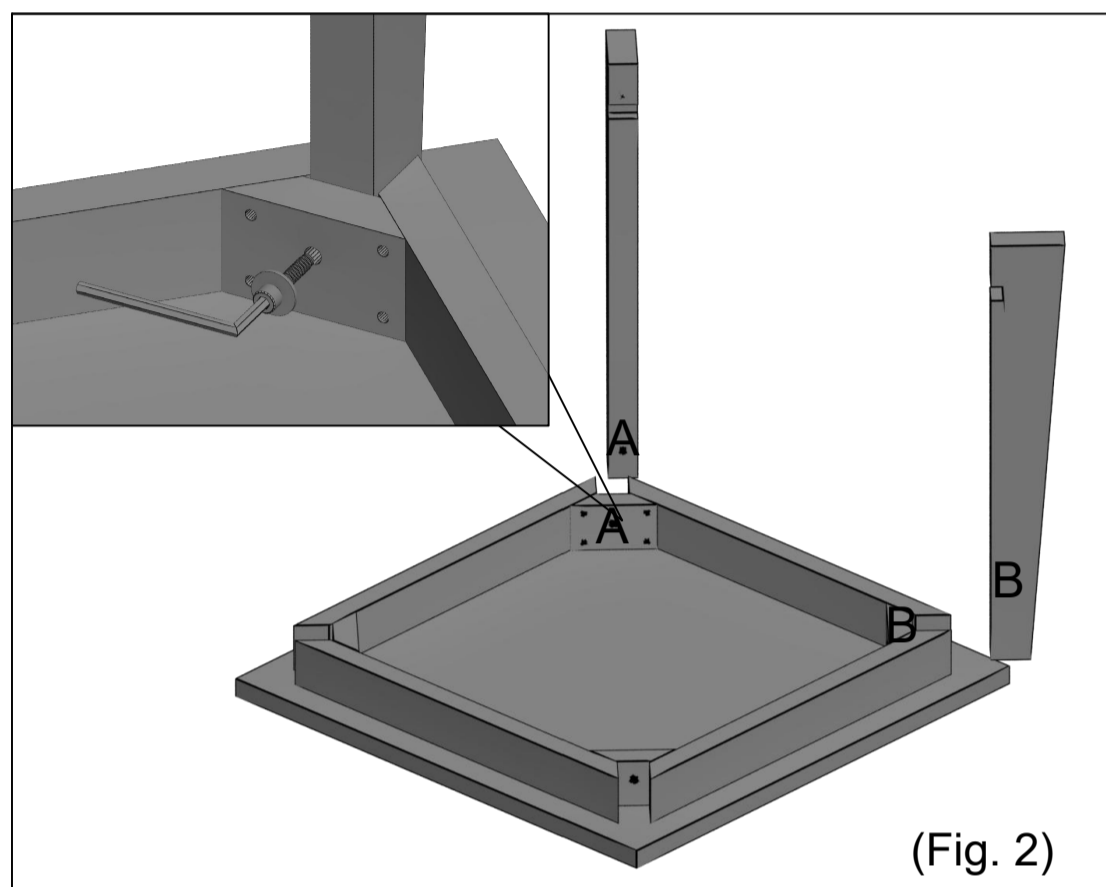

(Fig. 2)

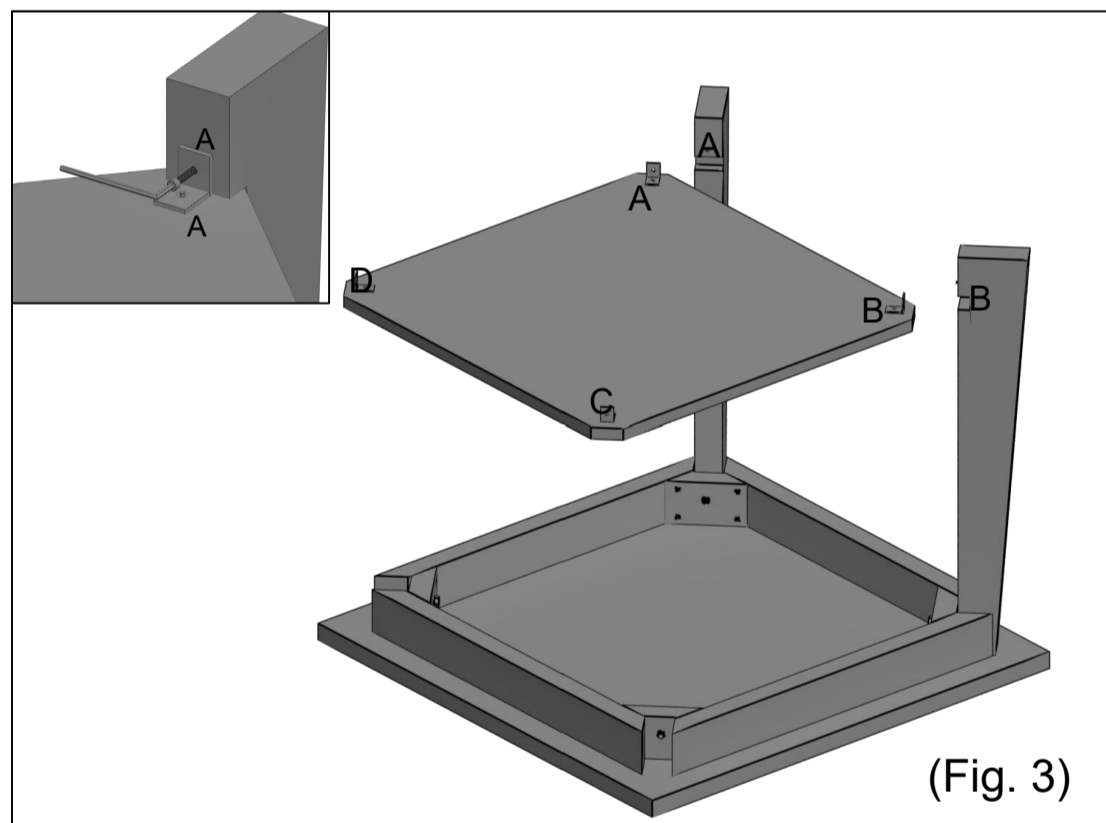

(Fig. 3)

Pre-assembly:

- Please read all instructions carefully before beginning assembling.
- It is recommended that assembly is done on a soft surface such as carpet to avoid any damage.
- We recommend adult assembly by two people for your safety.

Step 1 : Turn table top upside down onto a clean carpet as shown in the (Fig. 1).

Step 2 : First Match two legs label on table top with the label ("A" with "A" and "B" with "B") as shown in (Fig. 2).

Step 3 : Put the washer on to a bolt and insert into the corner leg, half tighten with the Allen key provided (Fig. 2).

Step 4 : Place the bottom plate and match label on leg with the label ("A" with "A" and "B" with "B") as shown in (Fig. 3).

Step 4 : Insert the bolt into the holes and tighten with the Allen key provided as show in (Fig. 3).

Step 7 : Repeat the same for remaining holes and tighten all bolts and screw to fasten securely.

Step 8 : Turn the table in upright position after assembly as shown in Fig. 5.

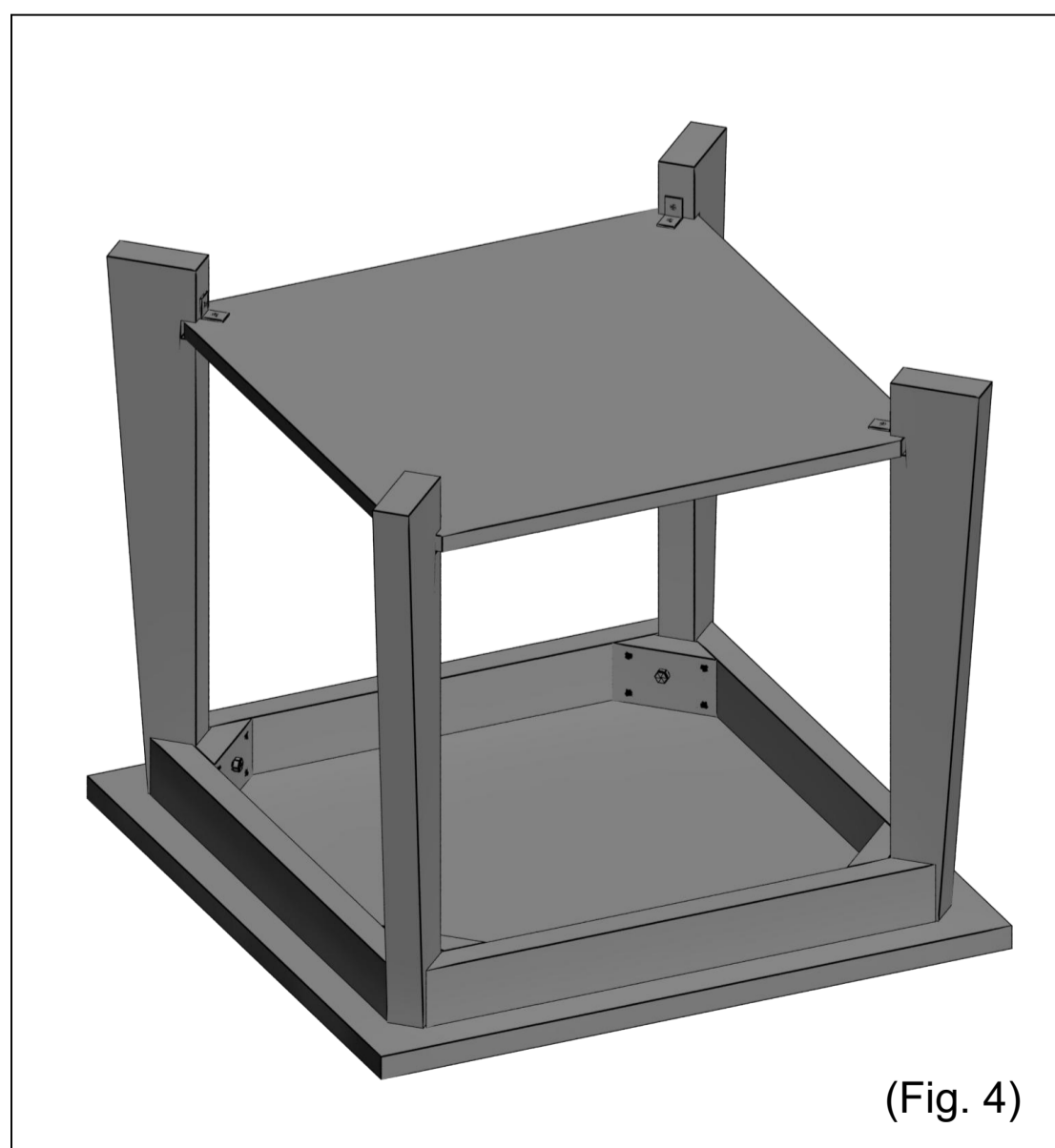

(Fig. 4)



(Fig. 5)

Care Information:

- Clean using a soft, dry cloth.
- Do not use harsh abrasives, chemicals or polishes containing silicone to as they can damage this finish.
- Avoid direct sunlight as this will cause the timber to change colour. • It is important to remove moist substances immediately