

# ASSEMBLY INSTRUCTIONS

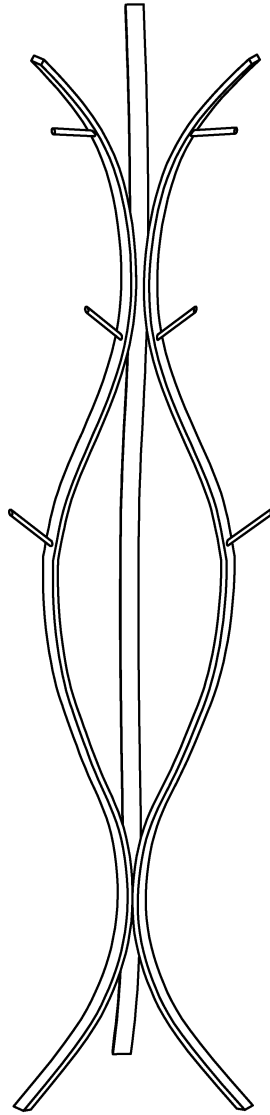



## Coat Rack



### NOTE TO CUSTOMERS:

- For ease and speed of assembly we recommend that before you commence each step of the assembly that you identify all the parts required to complete that step.
- We recommend that where possible you allow sufficient space to assemble the item as close as possible to the place where it will be once assembled.
- For the protection of your furniture we recommend that the product is placed on protected surfaces during assembly to prevent any damage.
- During assembly do not over tighten, as this may damage the product.
- Please ensure you retain all the product packaging until the item completely assembled.
- Please periodically check all fittings and re-tighten as necessary.
- Never allow any liquid to remain on your furniture as absorption can cause the wood to warp or the finish to de-laminate.
- It is recommended that this item should be assembled by two adults.

## Part List

A1	Quantity of 1	A2	Quantity of 2	A3	Quantity of 1	A4	Quantity of 2
							
Leg		Leg		Rod		Rod	

## Hardware List

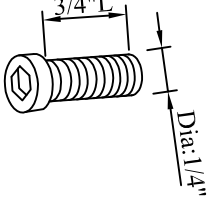
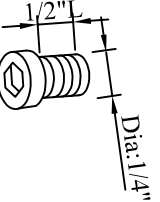
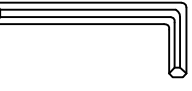
B1	Quantity of 4	B2	Quantity of 6		
					
Bolt		Bolt		Allen Wrench	

### STEP 1

B1 2pcs

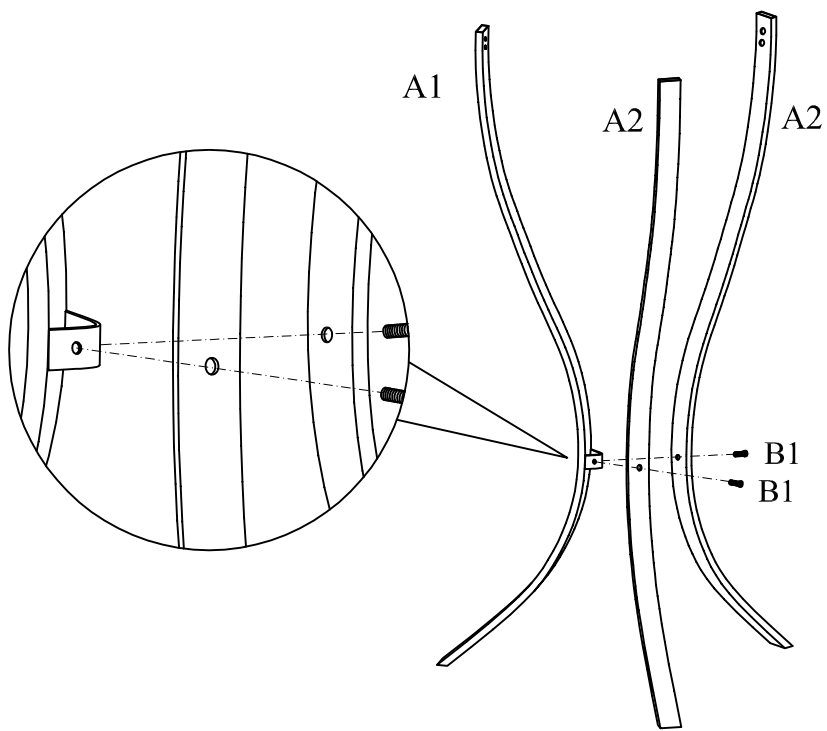

Assemble Legs A2 to Leg A1 using Bolts B1 as shown above.  
 Note: Please do not tighten Bolts B1 until Step 3.

**STEP 2**

B2  6pcs

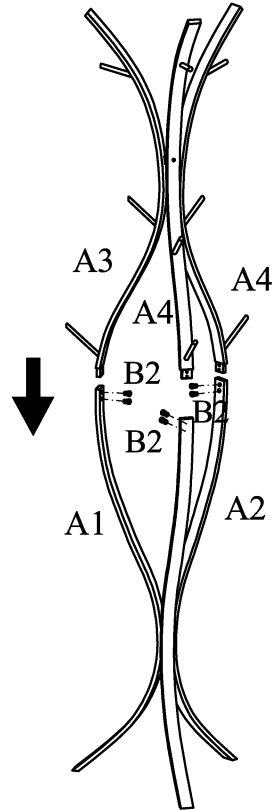

Insert and assemble Rods A3&A4 to Legs A1&A2 using Bolts B2 as shown above.

Note: Please do not tighten Bolts B2 until Step 3.

**STEP 3**

B1  2pcs

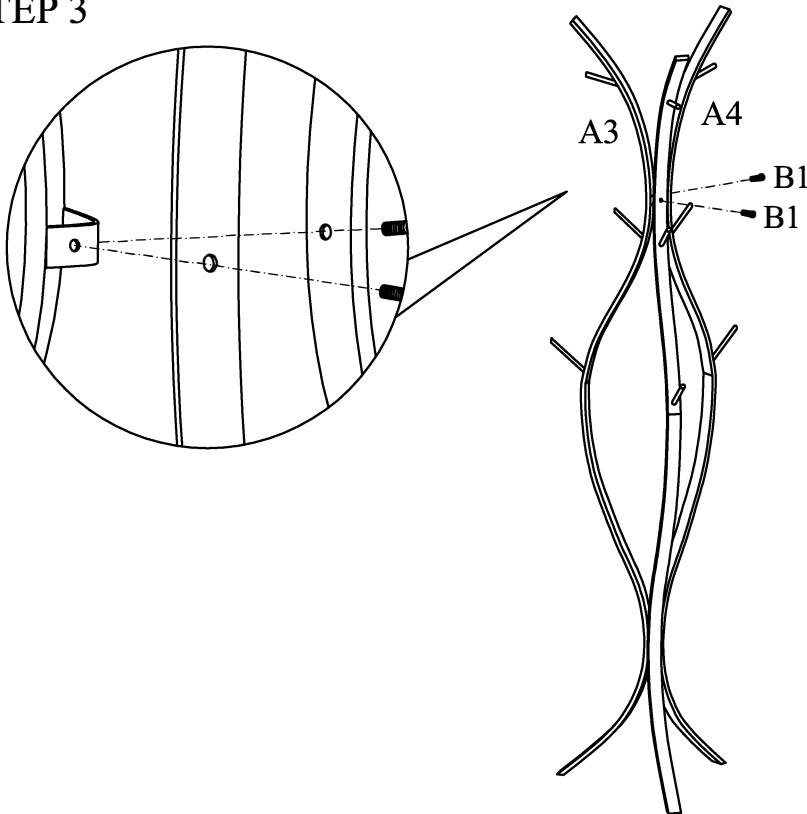

Assemble Rods A4 to Rod A3 using Bolts B1 as shown above.

Note: Place unit on the floor and check if it is stable before tightening all bolts