



ASSEMBLY INSTRUCTIONS



- Inspect the wire insulation for any cuts, abrasions or exposed copper that may have resulted during shipping. If there is a defect in the wire, do not attempt installation.
- Before starting installation of this fixture or removal of a previous fixture, disconnect the power by turning off the circuit breaker or by removing the fuse at the fuse box.

TOOLS REQUIRED

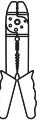
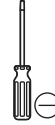
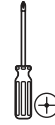

HARDWARE INCLUDED

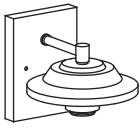

Fixture

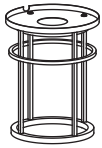

Cage



Glass shade

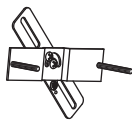

Mounting Unit



Ball Nuts



Rubber Rings



Mounting Screws



Wire Nuts

EXPLODED PARTS

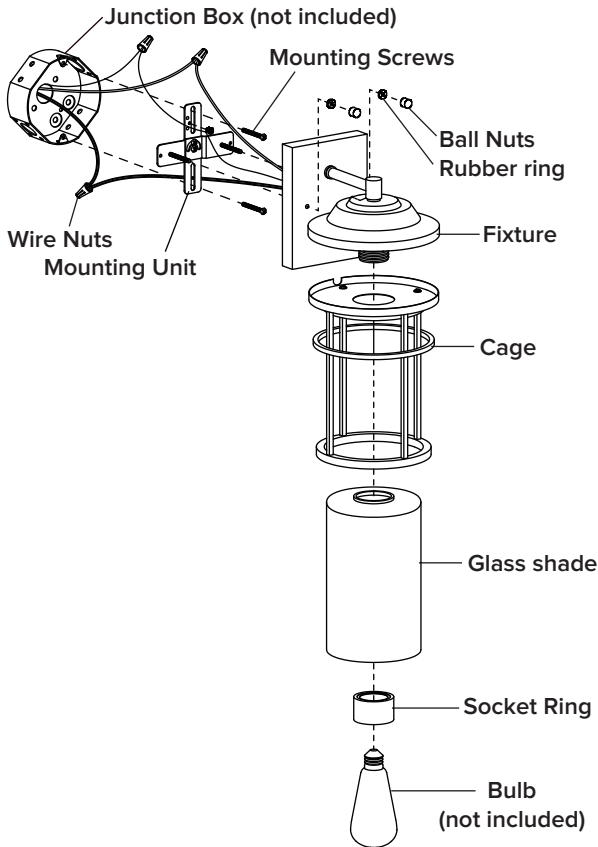

INSTALLATION

STEP 1

Unscrew the **rubber rings** and **ball nuts** from the **mounting unit**. Use the **mounting screws** to attach the **mounting unit** to the junction box (not included).

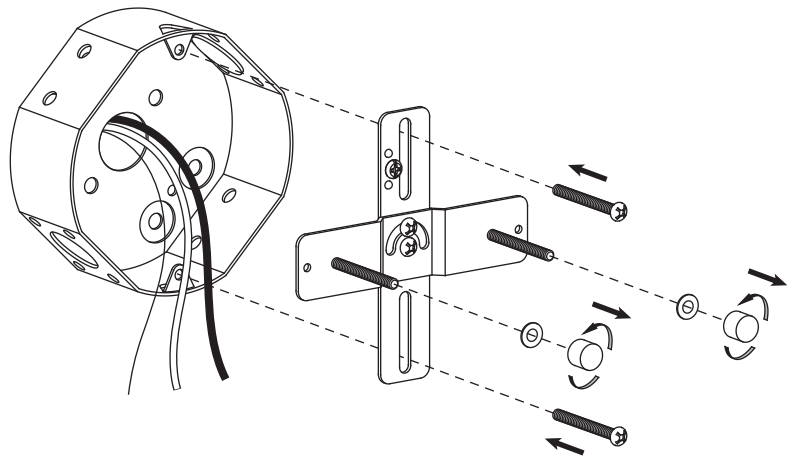

STEP 2

Make the electrical connection from the junction box (not included) to the **fixture**. Connect the ground wire to the **mounting unit** using the preinstalled green ground screw. Next, connect the live wire, neutral wire and ground wires with the supplied **wire nuts**. Secure with electrical tape.

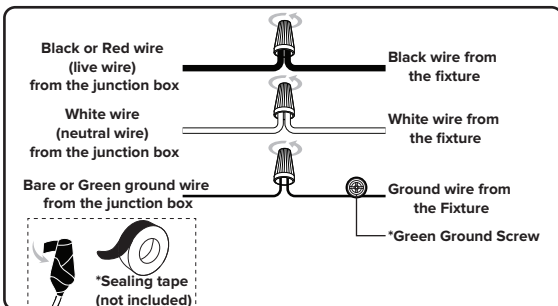
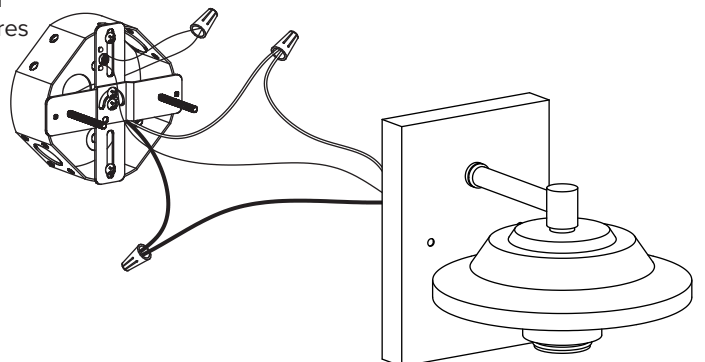

STEP 3

Attach the **fixture** to the **mounting unit** through screw holes as shown, and secure it with **rubber rings** and **ball nuts**.

NOTICE: Please use caulk in the back plate and wall mounting surface to prevent water from entering.

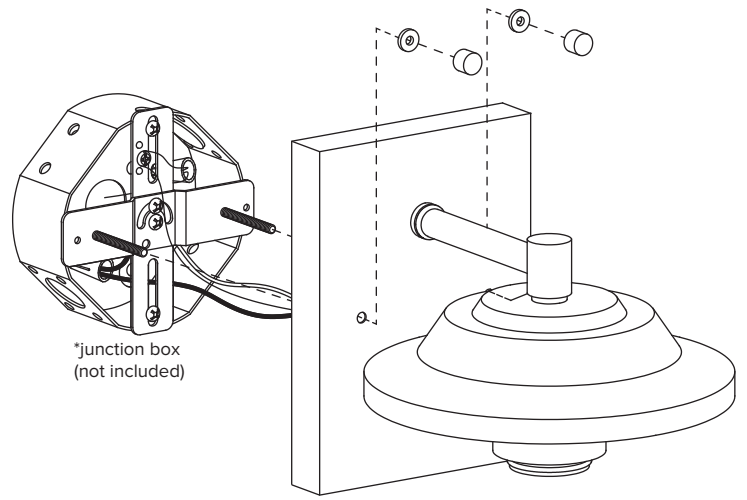

*junction box
(not included)

STEP 4

Remove the **socket ring** from the socket.
Attach the **glass shade** and **cage** onto **fixture** using **socket ring**.

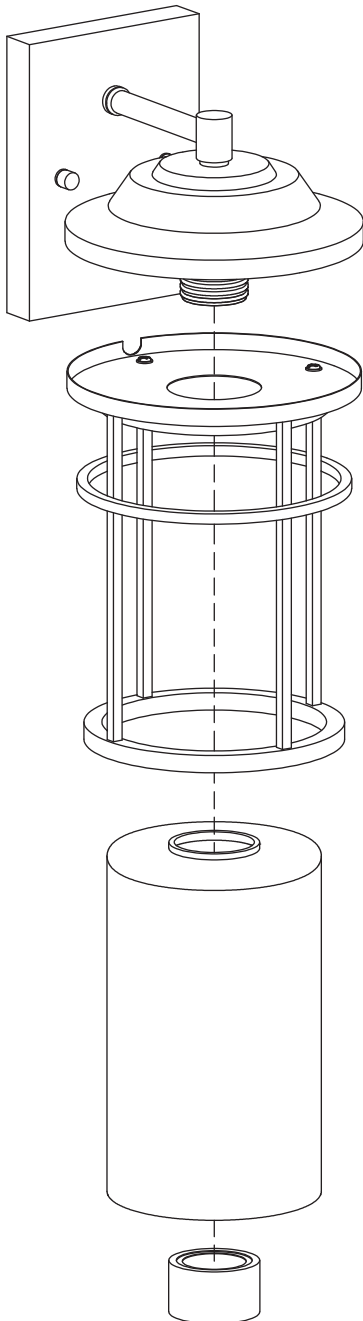

STEP 5

Install bulb (not included).

